



**BUILDING CODE COMPLIANCE OFFICE (BCCO)
PRODUCT CONTROL DIVISION**

**MIAMI-DADE COUNTY, FLORIDA
METRO-DADE FLAGLER BUILDING
140 WEST FLAGLER STREET, SUITE 1603
MIAMI, FLORIDA 33130-1563
(305) 375-2901 FAX (305) 375-2908**

NOTICE OF ACCEPTANCE (NOA)

**Southern Metals Manufacturing Co., Inc.
11801 Industry Drive
Jacksonville, FL. 32218**

SCOPE:

This NOA is being issued under the applicable rules and regulations governing the use of construction materials. The documentation submitted has been reviewed by the BCCO and accepted by the Building Code and Product Review Committee to be used in Miami Dade County and other areas where allowed by the Authority Having Jurisdiction (AHJ).

This NOA shall not be valid after the expiration date stated below. The BCCO (In Miami Dade County) and/or the AHJ (in areas other than Miami Dade County) reserve the right to have this product or material tested for quality assurance purposes. If this product or material fails to perform in the accepted manner, the manufacturer will incur the expense of such testing and the AHJ may immediately revoke, modify, or suspend the use of such product or material within their jurisdiction. BCCO reserves the right to revoke this acceptance, if it is determined by BCCO that this product or material fails to meet the requirements of the applicable building code.

This product is approved as described herein, and has been designed to comply with the South Florida Building Code, 1994 Edition for Miami-Dade County or Florida Building Code.

DESCRIPTION: 5-V Crimp Metal Roofing Panel System

RENEWAL of this NOA shall be considered after a renewal application has been filed and there has been no change in the applicable building code negatively affecting the performance of this product.

TERMINATION of this NOA will occur after the expiration date or if there has been a revision or change in the materials, use, and/or manufacture of the product or process. Misuse of this NOA as an endorsement of any product, for sales, advertising or any other purposes shall automatically terminate this NOA. Failure to comply with any section of this NOA shall be cause for termination and removal of NOA.

ADVERTISEMENT: The NOA number preceded by the words Miami-Dade County, Florida, and followed by the expiration date may be displayed in advertising literature. If any portion of the NOA is displayed, then it shall be done in its entirety.

INSPECTION: A copy of this entire NOA shall be provided to the user by the manufacturer or its distributors and shall be available for inspection at the job site at the request of the Building Official.

This NOA consists of pages 1 through 5,.
The submitted documentation was reviewed by Frank Zuloaga, RRC



**NOA No.: 01-0919.11
Expiration Date: 11/08/06
Approval Date: 11/08/01
Page 1 of 5**

ROOFING SYSTEM APPROVAL

Category: Roofing
Sub-Category: Non-Structural Metal Roofing
Material: Steel
Maximum Design Pressure: -57.5 psf.

TRADE NAMES OF PRODUCTS MANUFACTURED OR LABELED BY APPLICANT:

<u>Product</u>	<u>Dimensions</u>	<u>Test Specifications</u>	<u>Product Description</u>
5V Crimp Metal Roof Panels	Length : various Height : 7/16" Width: 25 1/2" (Coverage width: 24") Thickness : 0.0217	PA 125	Corrosion resistant, galvalume or galvanized performed, coated, pre-finished, metal panels.

EVIDENCE SUBMITTED :

<u>Test Agency</u>	<u>Test Identifier</u>	<u>Test Name/Report</u>	<u>Date</u>
Construction Research Laboratory, Inc.	5898A	<u>Direct Deck Test</u> Uplift Pressure Testing ASTM E 330 Wind Driven Rain <u>Over Battens Test</u>	Oct. 1993
Construction Research Laboratory, Inc.	5898B	Uplift Pressure Testing ASTM E 330 Wind Driven Rain	Oct. 1993
Hurricane Test Laboratories, Inc.	0041-0102-98	UL -580 test PA 125	Jan. 1998



NOA No.: 01-0919.11
Expiration Date: 11/08/06
Approval Date: 11/08/01
Page 2 of 5

APPROVAL ASSEMBLY:

System:	“5V-Crimp” Metal Panels
Deck Type:	Wood, Non-insulated
Deck Description:	$1\frac{9}{32}$ " or greater plywood or wood plank.
Slope Range:	2":12" or greater
Maximum Uplift Pressure:	The maximum allowable design pressure for the 24" wide panel shall be -57.5 psf.
Deck Attachment:	In accordance with applicable building code, but in no case it shall be less than # 8 x $1\frac{3}{4}$ " screws or 8d annular ring shank nails spaced at 6" o.c. In re-roofing, where deck is less than $1\frac{9}{32}$ " thick (minimum $1\frac{5}{32}$ "") the above attachment method must be in addition to existing attachment.
Underlayment:	Minimum underlayment shall be a ASTM D 226 Type II installed with a minimum 4" side-laps and 6" end-laps. Underlayment shall be fastened with corrosion resistant tin-caps and $1\frac{1}{4}$ " annular ring-shank nails, spaced 6" o.c. at all laps and two staggered rows 12" o.c. in the field of the roll.
Valleys:	Valley construction shall be in compliance with Roofing Application Standard RAS 133 and with current published installation instructions and details in Southeastern Metal Manufacturing Metal Roofing Installation Manual.
Fire Barrier Board:	For class A or B fire rating, install minimum $\frac{1}{4}$ " thick Georgia Pacific “Dens Deck” (with current NOA) or minimum 4mm thick of Tritex, RockRoof (with current NOA) or $\frac{5}{8}$ " water resistant type X gypsum sheathing with treated core and facer.
Metal Panels and Accessories:	<p>Install the "5V-Crimp Panels" and accessories in compliance with the current published installation instructions and details in Southeastern Metals Manufacturing Company's Installation Manual. Flashings, penetrations, valley construction and other details shall be constructed in compliance with Roofing Application Standard RAS133.</p> <ol style="list-style-type: none">1. At the eave, rake, and ridge, fasteners shall be located not more than 3" away from the panel end.2. The leading side edge of the panel should be the side with the anti-siphon groove; each panel side will overlap this channel to provide a capillary brake.3. The panels shall be fastened with #9 x 2" metal roofing sealing washer screws in the crown of the inverted V ribs as shown in the details herein.4. The panel's width fasteners shall be spaced at 11 $\frac{1}{2}$" to the center rib, Then 12 $\frac{1}{2}$" to the next, perpendicular to the slope, through the overlapping panel. The flat area of the panel as shown in the details herein.5. The panels fastening pattern at the interior of the panel, shall be in rows spaced 16" o.c. running parallel to the slope of the roof.



"5-V CRIMP" METAL ROOF PANELS

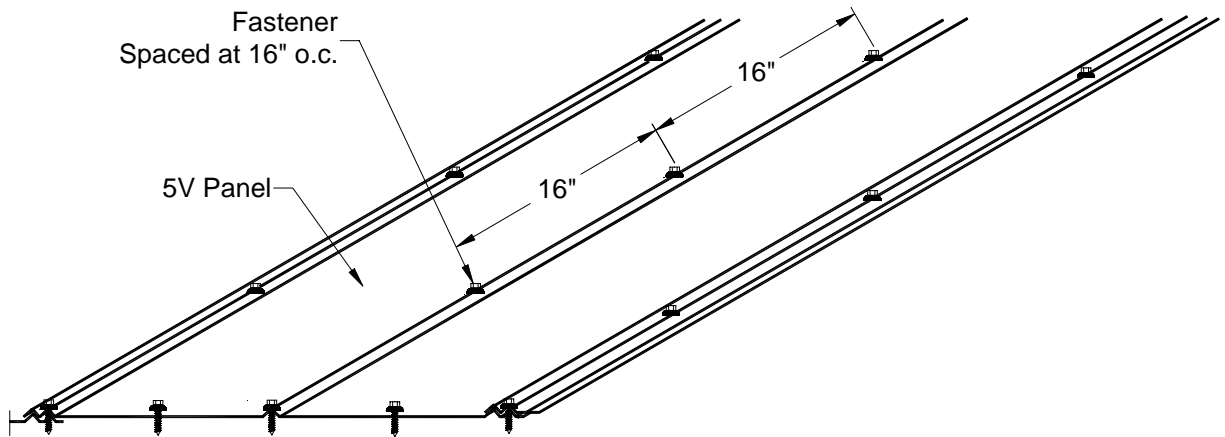
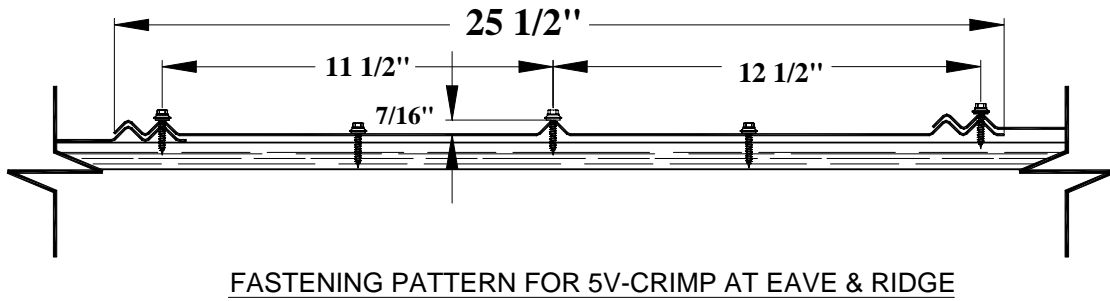
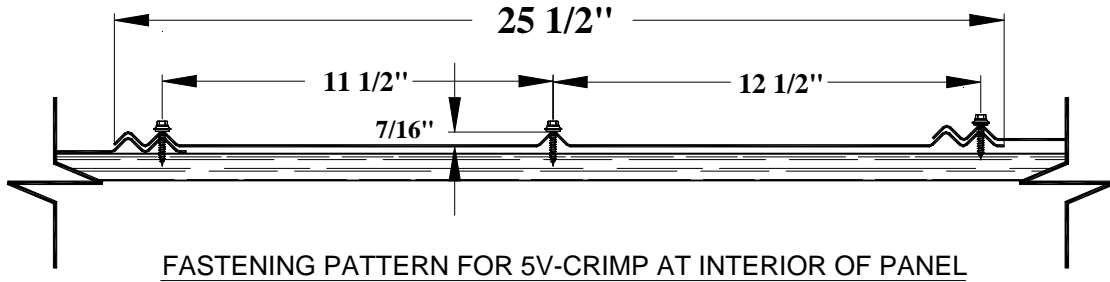

SYSTEM LIMITATIONS

1. Increased design pressures at perimeter and corner areas, in compliance with applicable building code may be met through rational analysis by increasing the number of attachment points in this areas. The maximum fastener spacing noted in the "Systems Description" section of this approval shall not be exceeded. All rational analysis computation shall be prepared, signed and sealed by a Florida Registered Professional Engineer, Registered Architect, or Registered Roof Consultant.
2. Panel shall be roll formed in continuous lengths from eave to ridge. Maximum lengths shall be described in the Roofing Application Protocol RAS 133.
3. All panels shall be permanently labeled with the manufacturer's name and/or logo, and the following statement: "Miami-Dade County Product Control Approved."

END OF THIS ACCEPTANCE



NOA No.: 01-0919.11
Expiration Date: 11/08/06
Approval Date: 11/08/01
Page 5 of 5