



BUILDING AND NEIGHBORHOOD COMPLIANCE DEPARTMENT (BNC)  
BOARD AND CODE ADMINISTRATION DIVISION

MIAMI-DADE COUNTY  
PRODUCT CONTROL SECTION  
11805 SW 26 Street, Room 208  
Miami, Florida 33175-2474  
T (786) 315-2590 F (786) 315-2599  
[www.miamidade.gov/building/](http://www.miamidade.gov/building/)

## NOTICE OF ACCEPTANCE (NOA)

**Convenience Products**  
**866 Horan Drive**  
**Fenton, MO. 63026**

### SCOPE:

This NOA is being issued under the applicable rules and regulations governing the use of construction materials. The documentation submitted has been reviewed and accepted by Miami-Dade County BNC - Product Control Section to be used in Miami Dade County and other areas where allowed by the Authority Having Jurisdiction (AHJ).

This NOA shall not be valid after the expiration date stated below. The Miami-Dade County Product Control Section (In Miami Dade County) and/or the AHJ (in areas other than Miami Dade County) reserve the right to have this product or material tested for quality assurance purposes. If this product or material fails to perform in the accepted manner, the manufacturer will incur the expense of such testing and the AHJ may immediately revoke, modify, or suspend the use of such product or material within their jurisdiction. BNC reserves the right to revoke this acceptance, if it is determined by Miami-Dade County Product Control Section that this product or material fails to meet the requirements of the applicable building code.

This product is approved as described herein, and has been designed to comply with the Florida Building Code including the High Velocity Hurricane Zone of the Florida Building Code.

### DESCRIPTION: Touch 'n Seal StormBond Roof Tile Adhesive

**LABELING:** Each unit shall bear a permanent label with the manufacturer's name or logo, city, state and following statement: "Miami-Dade County Product Control Approved", unless otherwise noted herein.

**RENEWAL** of this NOA shall be considered after a renewal application has been filed and there has been no change in the applicable building code negatively affecting the performance of this product.

**TERMINATION** of this NOA will occur after the expiration date or if there has been a revision or change in the materials, use, and/or manufacture of the product or process. Misuse of this NOA as an endorsement of any product, for sales, advertising or any other purposes shall automatically terminate this NOA. Failure to comply with any section of this NOA shall be cause for termination and removal of NOA.

**ADVERTISEMENT:** The NOA number preceded by the words Miami-Dade County, Florida, and followed by the expiration date may be displayed in advertising literature. If any portion of the NOA is displayed, then it shall be done in its entirety.

**INSPECTION:** A copy of this entire NOA shall be provided to the user by the manufacturer or its distributors and shall be available for inspection at the job site at the request of the Building Official.

This NOA consists of pages 1 through 12.  
The submitted documentation was reviewed by Alex Tigera.



**NOA No.: 11-0420.06**  
**Expiration Date: 07/21/16**  
**Approval Date: 07/21/11**  
**Page 1 of 12**

## ROOFING COMPONENT APPROVAL:

**Category:** Roofing  
**Sub Category:** Roof Tile adhesive  
**Materials:** Polyurethane

### SCOPE:

This approves **Touch ‘n Seal StormBond Roof Tile Adhesive** as manufactured by Convenience Products in Pacific, MO, as described in this Notice of Acceptance, designed to comply with the High Velocity Hurricane Zone of the Florida Building Code. For the locations where the pressure requirements, as determined by the applicable building code, do not exceed the design pressure values; as obtained by calculations in compliance with RAS 127, for use with approved flat, low, medium, and high profile roof tile systems using Touch ‘n Seal StormBond Roof Tile Adhesive, and where the attachment calculations shall be done as a momentum based system.

### PRODUCTS MANUFACTURED BY APPLICANT:

<u>Product</u>	<u>Dimensions</u>	<u>Test Specification</u>	<u>Product Description</u>
Touch ‘n Seal StormBond Roof Tile Adhesive	N/A	TAS 101	Single component Polyurethane foam roof tile adhesive

### PRODUCTS MANUFACTURED BY OTHERS:

Any Miami-Dade County Product Control Accepted Roof Tile Assembly having a current NOA which list uplift resistance values with the use of Touch ‘n Seal StormBond Roof Tile adhesive.

### MANUFACTURING LOCATION:

Pacific, MO

### PHYSICAL PROPERTIES:

<u>Property</u>	<u>Test</u>	<u>Results</u>
Compressive Strength :		
Parallel to rise:	ASTM D 1621	49.20 psi
Perpendicular to rise:		41.68psi
Density:	ASTM D 1622	1.88 lb/ft <sup>3</sup>
Tensile Strength:	ASTM D 1623	72.18 psi
Dimensional Stability:	ASTM D 2126	0.1% Volume Change @ -40°C, 2 weeks 6.0% Volume Change @70°C, 100% RH, 2 weeks
Closed Cell Content	ASTM D 2856	86.9%
Water Absorption:	ASTM D 2842	8.2%
Moisture Vapor Transmission	ASTM E 96	2.39 perms



NOA No.: 11-0420.06  
Expiration Date: 07/21/16  
Approval Date: 07/21/11  
Page 2 of 12

**EVIDENCE SUBMITTED:**

<u>Test Agency</u>	<u>Test Identifier</u>	<u>Test Name/Report</u>	<u>Date</u>
Momentum Technologies, Inc.	RX16D0A-3	ASTM D1623-78	09/28/10
Momentum Technologies, Inc.	RX16D0A-3	ASTM D1622-93	09/28/10
Momentum Technologies, Inc.	RX16D0A-3	ASTM D2126	09/28/10
Momentum Technologies, Inc.	RX16D0A-3	ASTM D1621-94	09/28/10
Momentum Technologies, Inc.	RX16D0A-3	ASTM D2842-94	09/28/10
R&D Services	RD102378WV	ASTM E96	08/17/10
R&D Services	RD102376OC	ASTM D2856-94	08/17/10
ATL of South Florida	1005.01-10	TAS 101	01/14/10
	1005.02-10	TAS 101	01/14/10
	1005.03-10	TAS 101	01/14/10
	1005.05-10	TAS 101	01/15/10
	1005.06-10	TAS 101	01/15/10
	0215.10-10	TAS 101	02/15/10

**LIMITATIONS:**

1. Fire classification is not part of this acceptance.
2. All approved products listed herein shall be labeled and shall bear the imprint or identifiable marking of the manufacturer's name or logo and following statement: "Miami-Dade County Product Control Approved" or the Miami-Dade County Product Control Seal as shown below.



3. Touch 'n Seal StormBond Roof Tile Adhesive shall solely be used with flat, low, medium, and high tile profiles
4. Minimum underlayment shall be in compliance with the Roofing Application Standard RAS 120.
5. Roof Tile manufactures acquiring acceptance for the use of Touch 'n Seal StormBond Roof Tile Adhesive with their tile assemblies shall test in accordance with RAS 101 with section 10.4 as modified herein.

$$F' = \frac{\left(\frac{F}{2}\right) - W}{MS}$$



## INSTALLATION:

1. Touch 'n Seal StormBond Roof Tile Adhesive may be used with any roof tile assembly having a current NOA that lists uplift resistance values with the use of Touch 'n Seal StormBond Roof Tile Adhesive.
2. Touch 'n Seal StormBond Roof Tile Adhesive shall be applied in compliance with the Component Application section and the corresponding Placement Details noted herein. The roof tile assembly's adhesive attachment with the use of Touch 'n Seal StormBond Roof Tile Adhesive shall provide sufficient attachment resistance, expressed as a moment based system, to meet or exceed the moment resistance determined in compliance with Roofing Application Standards RAS 127. The adhesive attachment data is noted in the roof tile assembly NOA.
3. Touch 'n Seal StormBond Roof Tile Adhesive roof tile adhesive and its components shall be installed in accordance with Roofing Application Standard RAS 120, and Touch 'n Seal StormBond Roof Tile Adhesive Application Instructions.
4. Installation must be by a Factory Trained 'Qualified Applicator' approved and licensed by Convenience Products.
5. Pressure treated wood filler block shall be required on all eave course of all tile profiles, except on two piece barrel tile.
6. Tiles must be adhered in freshly applied adhesive. Tile must be set within 4 minutes after Touch 'n Seal StormBond Roof Tile Adhesive has been dispensed.
7. Touch 'n Seal StormBond Roof Tile Adhesive placement and minimum bead weight shall be in accordance with the 'Placement Details' herein. Each generic tile profile requires the specific placement noted herein.

<b>Table 1: Adhesive Placement for Clay Tile</b>					
<b>Tile</b>		<b>Placement Detail</b>		<b>Two Bead Weight per bead Min. (grams)</b>	<b>Contact Area (Square inches)</b>
<b>Type</b>	<b>Profile</b>	<b>Detail No.</b>	<b>Adhesive Location</b>		
Concrete	Flat/Low	1	Head Right Side	10.2 18.3	22.5
Concrete	Low/Medium	2	Head Flange	5.1 8.4	20.0
Concrete	High	3	Head Flange	3.9 8.4	18.5
Clay	Flat	4	Head Right Side	2.8 3.9	10.0
Clay	Low	5	Head Flange	2.8 5.1	11.5
Clay	High-S	6	Head Flange	3.3 8.4	11.5
Clay	High-Barrel	7	Cap Pan	8.1 8.1	22.5 15.0



NOA No.: 11-0420.06  
 Expiration Date: 07/21/16  
 Approval Date: 07/21/11  
 Page 4 of 12

**LABELING:**

Touch 'n Seal StormBond Roof Tile Adhesive containers shall comply with the conditions listed under Limitation #2 listed herein.

**BUILDING PERMIT REQUIREMENTS:**

As required by the Building Official or applicable building code in order to properly evaluate the installation of this system.



# TOUCH 'N SEAL STORMBOND ROOF TILE ADHESIVE PLACEMENT DETAIL DOUBLE BEAD SYSTEM

DRAWING #1  
CONCRETE TILE - FLAT/LOW PROFILE

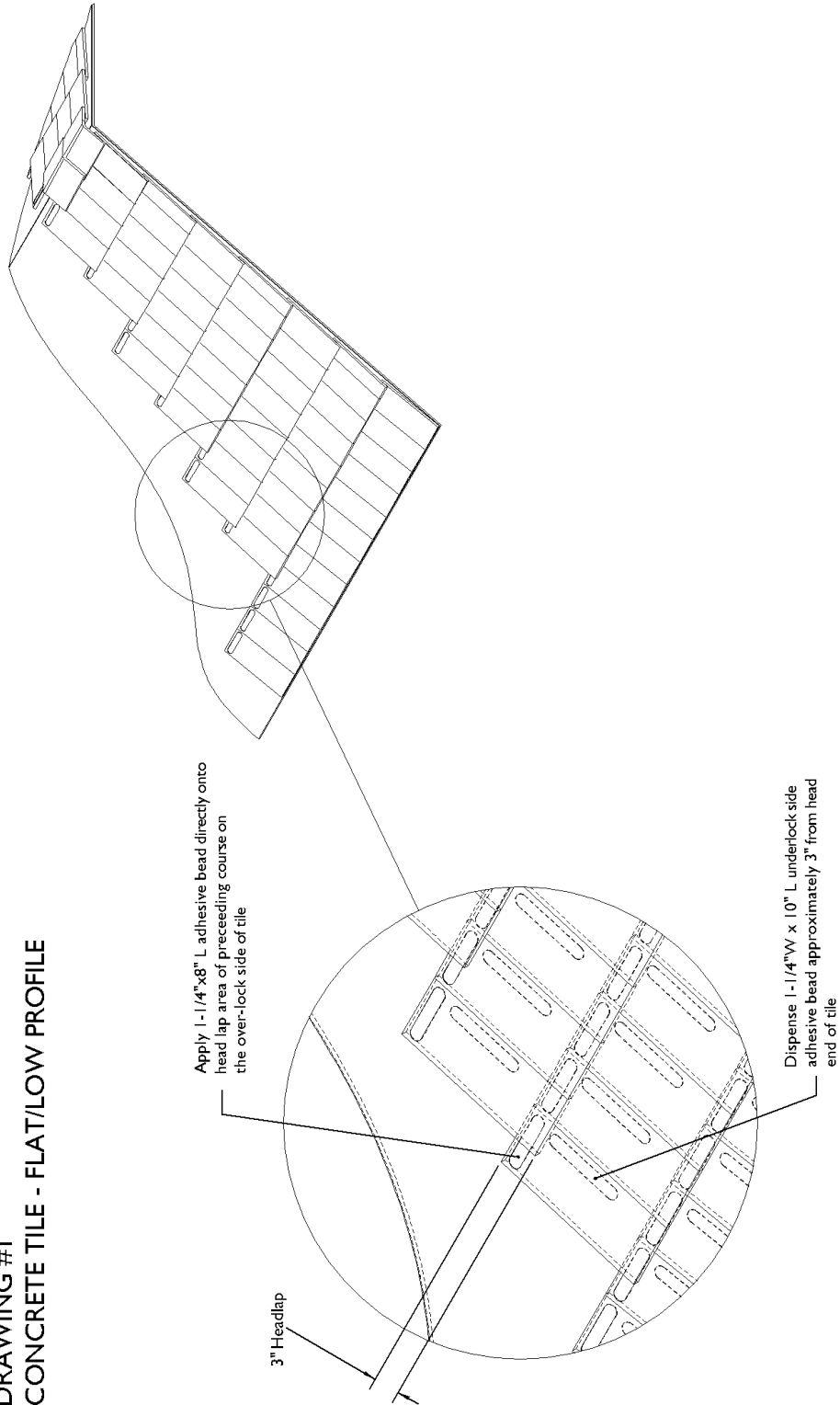

NOA No.: 11-0420.06  
Expiration Date: 07/21/16  
Approval Date: 07/21/11  
Page 6 of 12



**DRAWING #2  
CONCRETE TILE - LOW/MEDIUM PROFILE**

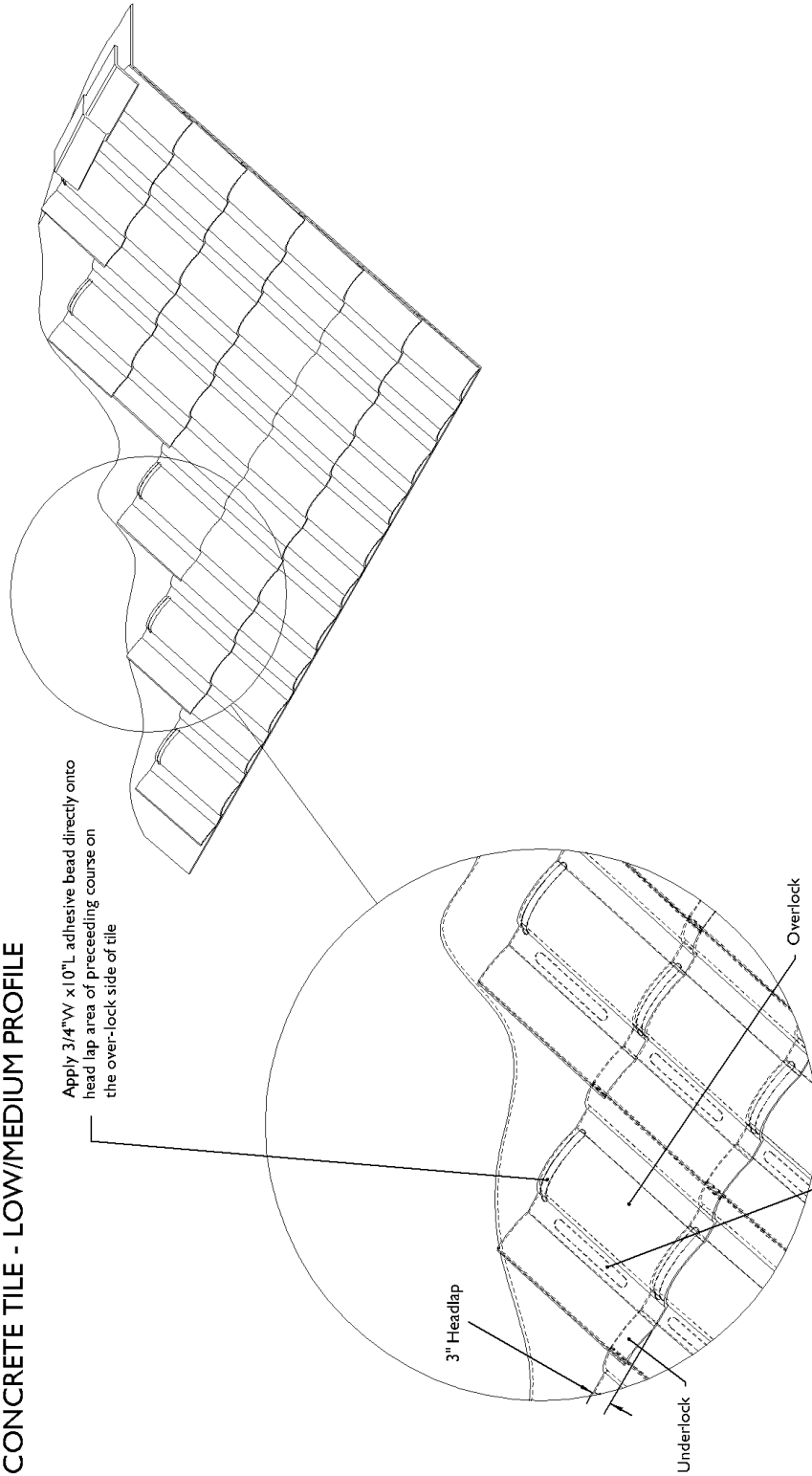

Apply 3/4"W x 10"L adhesive bead directly onto head lap area of preceding course on the over-lock side of tile

Dispense 1-1/4"W x 10" L adhesive bead under valley of tile directly opposite underlock approximately 3" from head end of underlying tile



**DRAWING #3  
CONCRETE TILE - HIGH PROFILE**

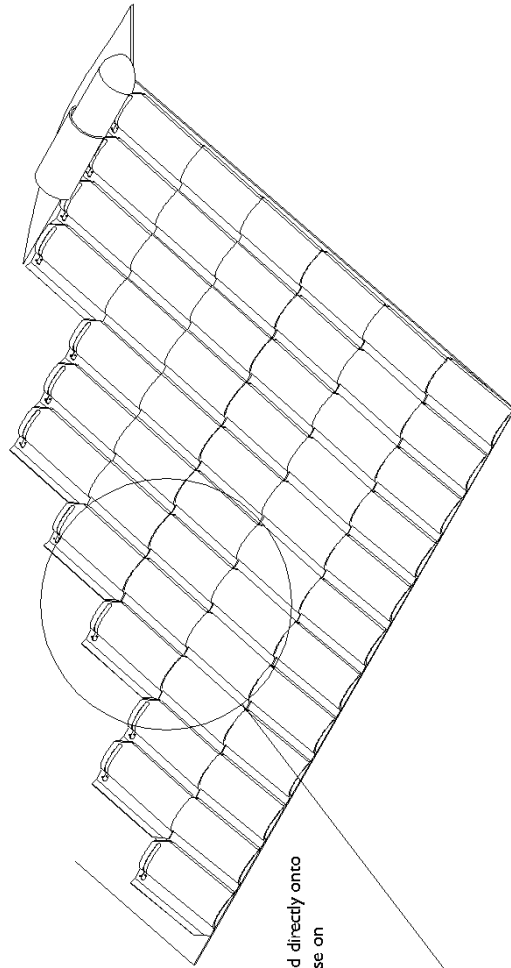

Apply 3/4"W x 8"L adhesive bead directly onto head lap area of preceding course on the over-lock side of tile

3" Headlap

Apply adhesive bead directly on capsheet

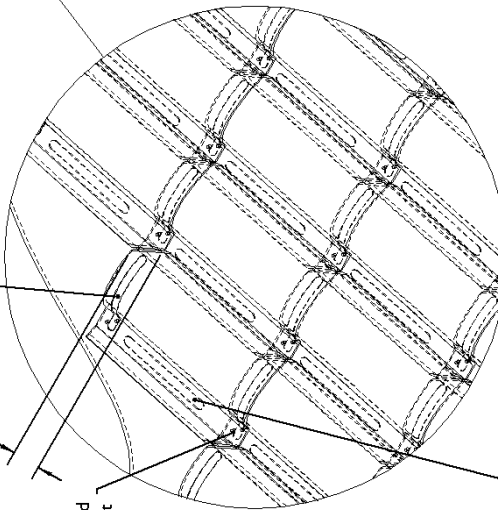

Dispense 1-1/4"W x 10"L adhesive bead under center of tile flange approximately 3" from head end of tile





**DRAWING #4  
CLAY TILE - FLAT PROFILE**

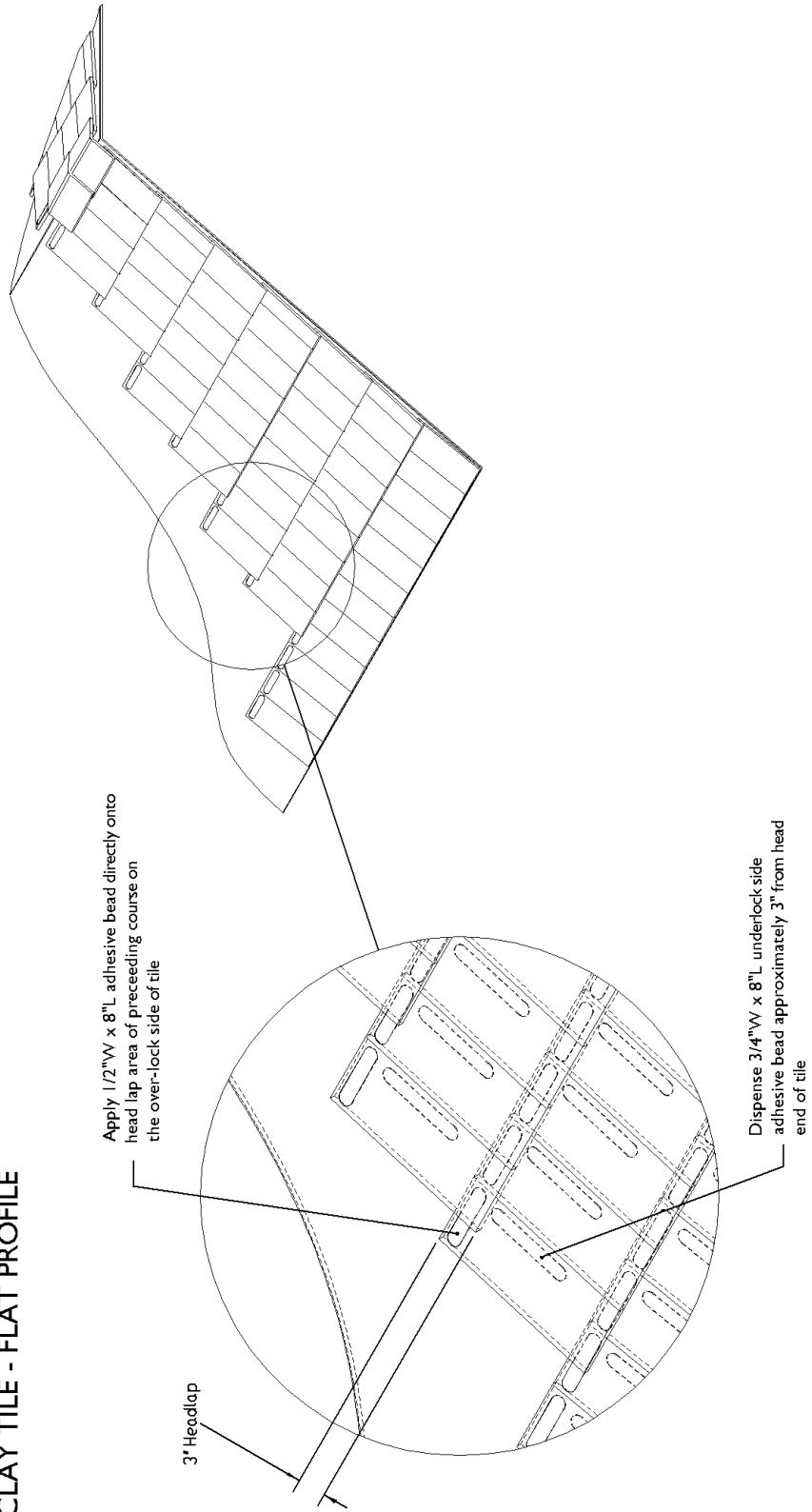

**DRAWING #5  
CLAY TILE - LOW PROFILE**

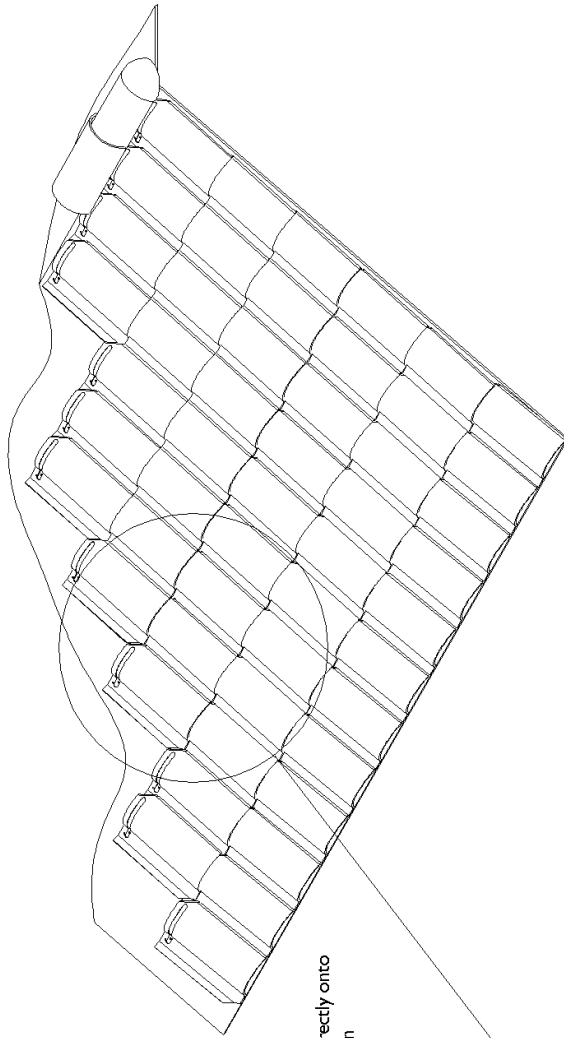

Apply 1/2"W x 8"L adhesive bead directly onto head lap area of preceding course on the over-lock side of tile

3" Headlap

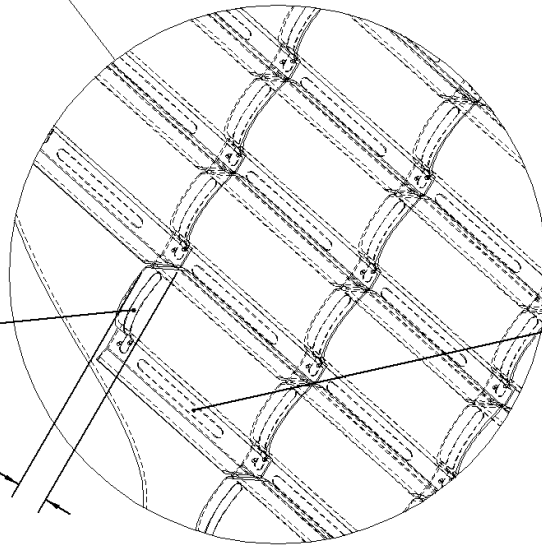

Dispense 3/4"W x 10" L adhesive bead approximately 3" from head end of tile



**DRAWING #6  
CLAY TILE - HIGH PROFILE, S-TILE**

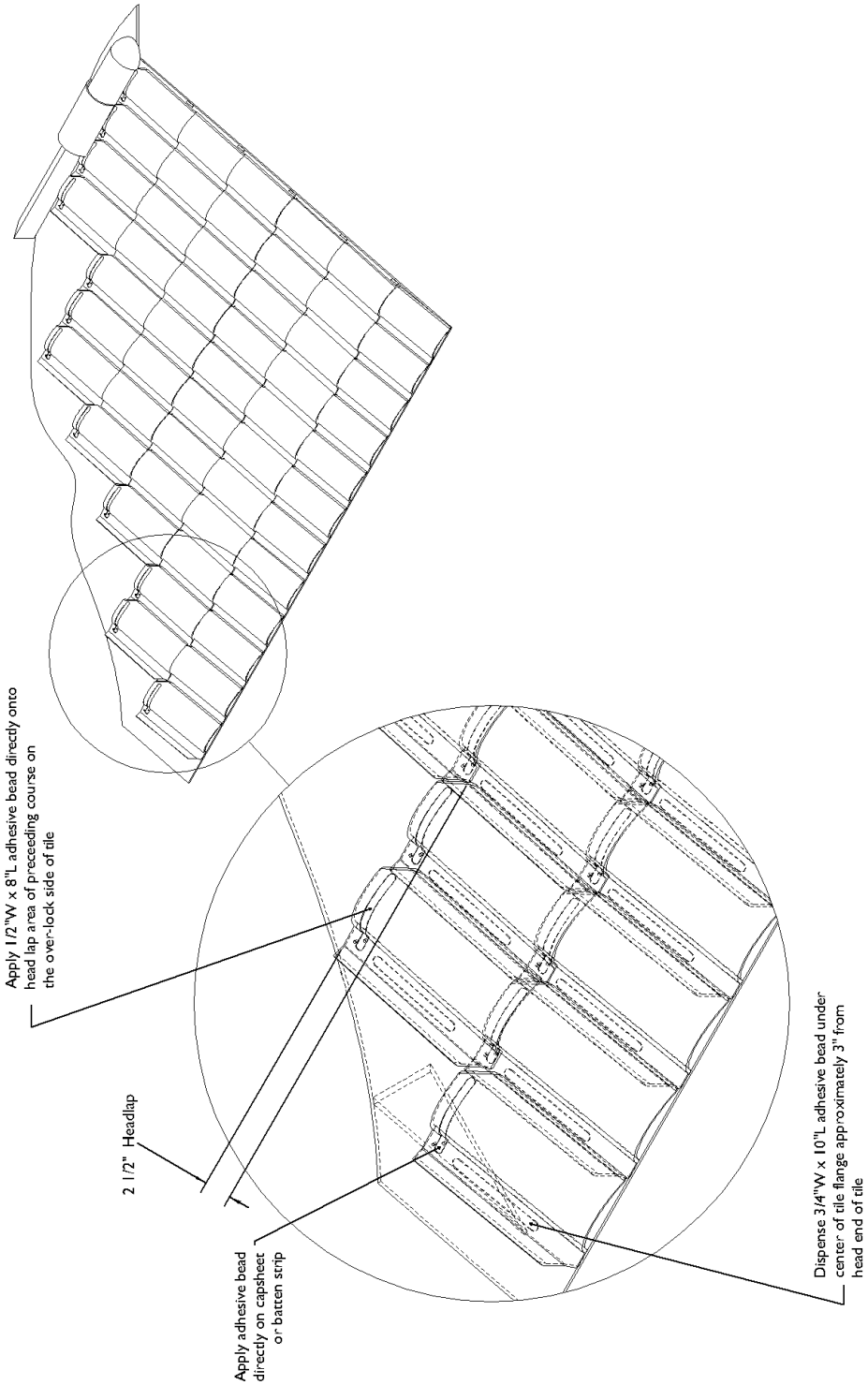

**DRAWING #7  
CLAY TILE - HIGH PROFILE, BARREL TILE**

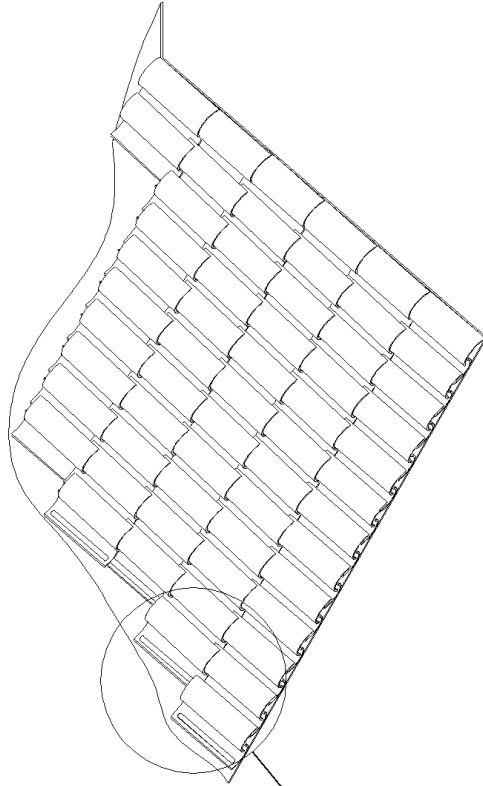

Apply 3/4"W x 15"L adhesive bead directly onto the Captile on each side of the pan

3" Headlap

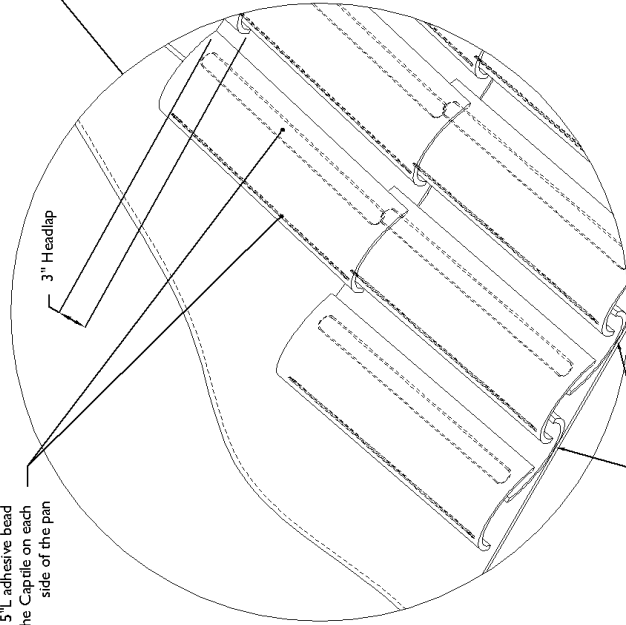

(See Detail "A")

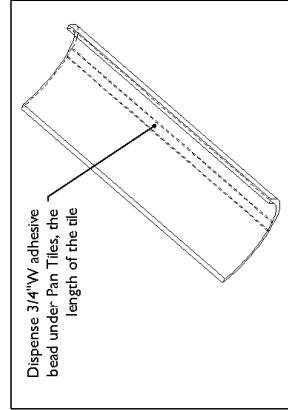

**Detail "A"**

**END OF THIS ACCEPTANCE**



**NOA No.: 11-0420.06  
Expiration Date: 07/21/16  
Approval Date: 07/21/11  
Page 12 of 12**