



BUILDING AND NEIGHBORHOOD COMPLIANCE DEPARTMENT (BNC)  
BOARD AND CODE ADMINISTRATION DIVISION

MIAMI-DADE COUNTY  
PRODUCT CONTROL SECTION  
11805 SW 26 Street, Room 208  
Miami, Florida 33175-2474  
T (786) 315-2590 F (786) 315-2599  
[www.miamidade.gov/building/](http://www.miamidade.gov/building/)

## NOTICE OF ACCEPTANCE (NOA)

**The Dow Chemical Company**  
1605 Joseph Drive  
200 Larkin Center  
Midland, MI 48674

### SCOPE:

This NOA is being issued under the applicable rules and regulations governing the use of construction materials. The documentation submitted has been reviewed and accepted by Miami-Dade County BNC - Product Control Section to be used in Miami Dade County and other areas where allowed by the Authority Having Jurisdiction (AHJ).

This NOA shall not be valid after the expiration date stated below. The Miami-Dade County Product Control Section (In Miami Dade County) and/or the AHJ (in areas other than Miami Dade County) reserve the right to have this product or material tested for quality assurance purposes. If this product or material fails to perform in the accepted manner, the manufacturer will incur the expense of such testing and the AHJ may immediately revoke, modify, or suspend the use of such product or material within their jurisdiction. BNC reserves the right to revoke this acceptance, if it is determined by Miami-Dade County Product Control Section that this product or material fails to meet the requirements of the applicable building code. This product is approved as described herein, and has been designed to comply with the Florida Building Code including the High Velocity Hurricane Zone of the Florida Building Code.

### DESCRIPTION: TILE BOND™ Roof Tile Adhesive

**LABELING:** Each unit shall bear a permanent label with the manufacturer's name or logo, city, state and following statement: "Miami-Dade County Product Control Approved", unless otherwise noted herein.

**RENEWAL** of this NOA shall be considered after a renewal application has been filed and there has been no change in the applicable building code negatively affecting the performance of this product.

**TERMINATION** of this NOA will occur after the expiration date or if there has been a revision or change in the materials, use, and/or manufacture of the product or process. Misuse of this NOA as an endorsement of any product, for sales, advertising or any other purposes shall automatically terminate this NOA. Failure to comply with any section of this NOA shall be cause for termination and removal of NOA.

**ADVERTISEMENT:** The NOA number preceded by the words Miami-Dade County, Florida, and followed by the expiration date may be displayed in advertising literature. If any portion of the NOA is displayed, then it shall be done in its entirety.

**INSPECTION:** A copy of this entire NOA shall be provided to the user by the manufacturer or its distributors and shall be available for inspection at the job site at the request of the Building Official.

This renews and revises NOA# 08-0512.18 consists of pages 1 through 9.  
The submitted documentation was reviewed by Alex Tigera.



NOA No.: 11-0616.03  
Expiration Date: 08/23/16  
Approval Date: 08/18/11  
Page 1 of 9

## ROOFING COMPONENT APPROVAL

**Category:** Roofing  
**Sub Category:** Roof Tile Adhesive  
**Material:** Polyurethane

### SCOPE:

This approves **TILE BOND™ Roof Tile Adhesive** as manufactured by **The Dow Chemical Company**, as described in this Notice of Acceptance, designed to comply with the High Velocity Hurricane Zone of the Florida Building Code. For the locations where the pressure requirements, as determined by applicable building code, do not exceed the design pressure values; as obtained by calculations in compliance with RAS 127, using **TILE BOND™ Roof Tile Adhesive**, and where the attachment calculations shall be done as an moment based system.

### PRODUCT DESCRIPTION:

<b>Manufactured by <u>Applicant</u></b>	<b><u>Dimensions</u></b>	<b><u>Product Description</u></b>
TILE BOND™ Roof Tile Adhesive	Factory premixed canisters	Single component polyurethane foam roof tile adhesive

### MANUFACTURING LOCATION:

1. Wilmington, IL.



NOA No.: 11-0616.03  
Expiration Date: 08/23/16  
Approval Date: 08/18/11  
Page 2 of 9

**EVIDENCE SUBMITTED:**

<u>Test Agency</u>	<u>Test Identifier</u>	<u>Test Name/Report</u>	<u>Date</u>
Center for Applied Engineering	25-7512-1	TAS 101	01/25/96
	25-7512-2	TAS 101	01/25/96
	25-7512-3	TAS 101	01/25/96
	25-77512-4	TAS 101	01/25/96
	25-7781	Physical Properties Testing	11/07/96
	257794-2	SSTD 11-93	10/03/96
South Research Institute	01.8366-014	ASTM E108-95a	February 1997
Walker Engineering, Inc.	N/A	Evaluation of Test on a Two-pad System	12/16/97
Celotex Corp. Testing Services	520111-1	TAS 101	12/28/98
	520111-2	TAS 101	12/28/98
	520111-3	TAS 101	12/28/98
	520111-4	TAS 101	12/28/98
	520111-7	TAS 101	12/28/98
	520111-8	TAS 101	12/28/98
	520111-12	TAS 101	12/28/98
	520135-3	TAS 101	02/01/99
	520135-4	TAS 101	02/01/99
	520135-5	TAS 101	02/01/99
IBA Consultants Inc.	4848-8	TAS 101	05/19/08
	4848-7	TAS 101	05/19/08
	4848-6	TAS 101	05/19/08
	4848-5	TAS 101	05/19/08
	4848-4	TAS 101	05/19/08
	4848-3	TAS 101	05/19/08
	4848-2	TAS 101	05/19/08
	4848-1	TAS 101	05/19/08
Trinity ERD	D9840.09.09	TAS 110	09/17/09



**TYPICAL PHYSICAL PROPERTIES:**

<u>Property</u>	<u>Test</u>	<u>Results</u>
Density	ASTM D 1622	1.83 lbs./ft. <sup>3</sup>
Compressive Strength	ASTM D 1621	14.31 psi
Tensile Strength	ASTM D 1623	31.2 lbf @ 180°F, 65% RH for 120 days, concrete to concrete
Water Absorption	ASTM D 2842	2.21% absorbed by Volume
Moisture Vapor Transmission	ASTM E 96	3.00 Perm / Inch
Dimensional Stability	ASTM D 2126	-0.47% Volume Change @ -40°C., 2 weeks -4.05% Volume Change @ 70°C., 100% Humidity, 2 weeks
Closed Cell Content	ASTM D 2856	86.3%

**LIMITATIONS:**

1. Fire classification is not part of this acceptance.
2. All approved products listed herein shall be labeled and shall bear the imprint or identifiable marking of the manufacturer's name or logo and following statement: "Miami-Dade County Product Control Approved" or the Miami-Dade County Product Control Seal as shown below.



3. TILE BOND™ Roof Tile Adhesive shall solely be used with flat, low, medium, and high tile profiles.
4. Minimum underlayment shall be in compliance with the Roofing Application Standard RAS 120.
5. Roof Tile manufactures acquiring acceptance for the use of TILE BOND™ Roof Tile Adhesive roof tile adhesive with their tile assemblies shall test in accordance with TAS 101 with section 10.4 as modified herein.

$$6. F' = \frac{\left(\frac{F}{2}\right) - W}{MS}$$



## INSTALLATION:

1. TILE BOND™ Roof Tile Adhesive may used with any roof tile assembly having a current NOA that lists uplift resistance values with the use of TILE BOND™ Roof Tile Adhesive.
2. TILE BOND™ Roof Tile Adhesive shall be applied in compliance with the Component Application section and the corresponding Placement Details noted herein. The roof tile assembly's adhesive attachment with the use of TILE BOND™ Roof Tile Adhesive shall provide sufficient attachment resistance, expressed as an uplift based system, to meet or exceed the uplift resistance determined in compliance with Roofing Application Standards RAS 127. The adhesive attachment data is noted in the roof tile assembly NOA
3. TILE BOND™ Roof Tile Adhesive roof tile adhesive and its components shall be installed in accordance with Roofing Application Standard RAS 120, and The Dow Chemical Company TILE BOND™ Roof Tile Adhesive Operating Instruction and Maintenance Booklet.
4. Installation must be by a Factory Trained 'Qualified Applicator' approved and licensed by The Dow Chemical Company.
5. Pressure treated wood filler block shall be required on all eave course of all tile profiles, except on two piece barrel tile
6. Tiles must be adhered in freshly applied adhesive. Tile must be set within 4 minutes after TILE BOND™ Roof Tile Adhesive has been dispensed.
7. TILE BOND™ Roof Tile Adhesive placement and minimum patty weight shall be in accordance with the 'Placement Details' herein. Each generic tile profile requires the specific placement noted herein.

<b>Tile Profile</b>	<b>Placement Detail</b>	<b>Minimum patty Weight per tile (grams)</b>	<b>Contact Area (Square inches)</b>
Flat / Low Profile	#1	11.1	19.5
Medium Profile	#2	11.0	19.5
High Profile ( Head)	#3	22.0	39
High Profile (Nose)	#3	11.0	19.5
Two Piece Barrel	#4	11.6	20

## LABELING:

All TILE BOND™ Roof Tile Adhesive containers shall comply with the Standard Conditions listed herein.

## BUILDING PERMIT REQUIREMENTS:

Any documentation required by the Building Official or applicable building code in order to properly evaluate the installation of this system



# ADHESIVE PLACEMNT DETAIL

## LOW (FLAT) PROFILE DETAIL #1

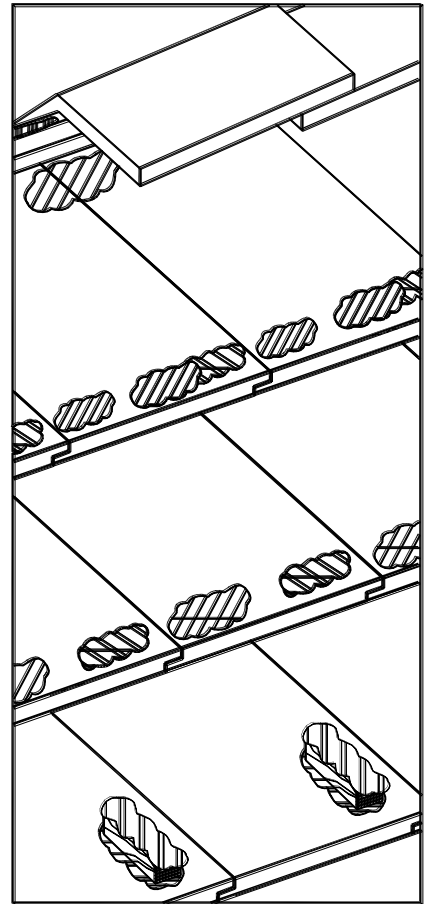
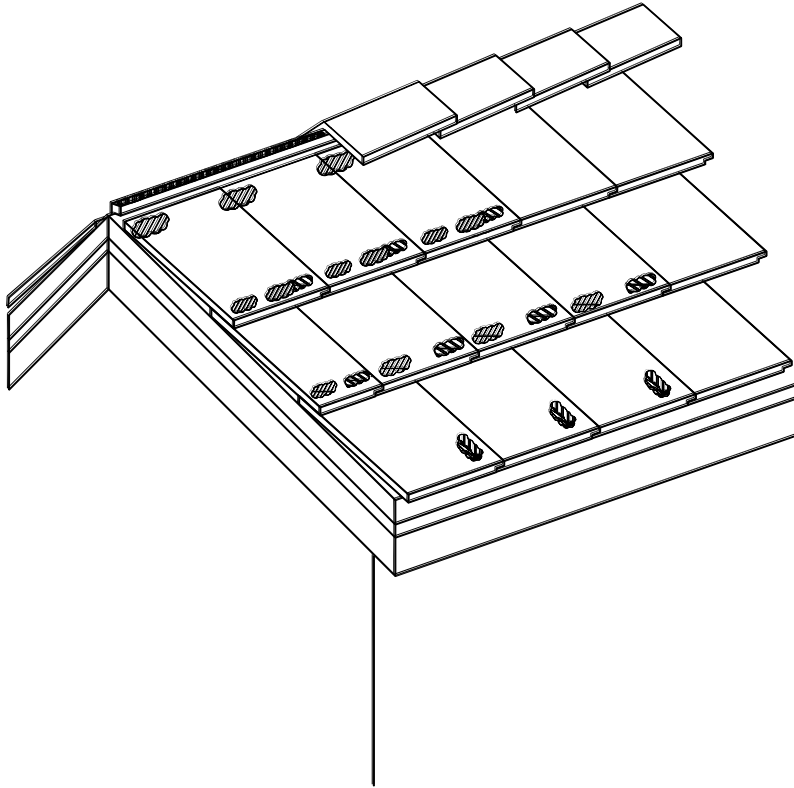

**MEDIUM PROFILE  
DETAIL #2**

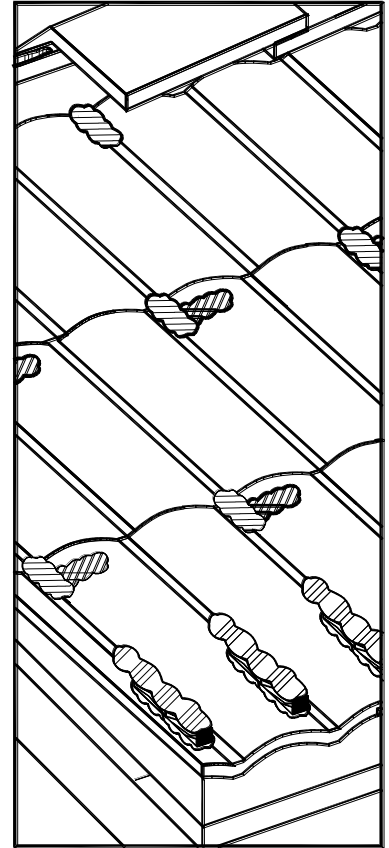
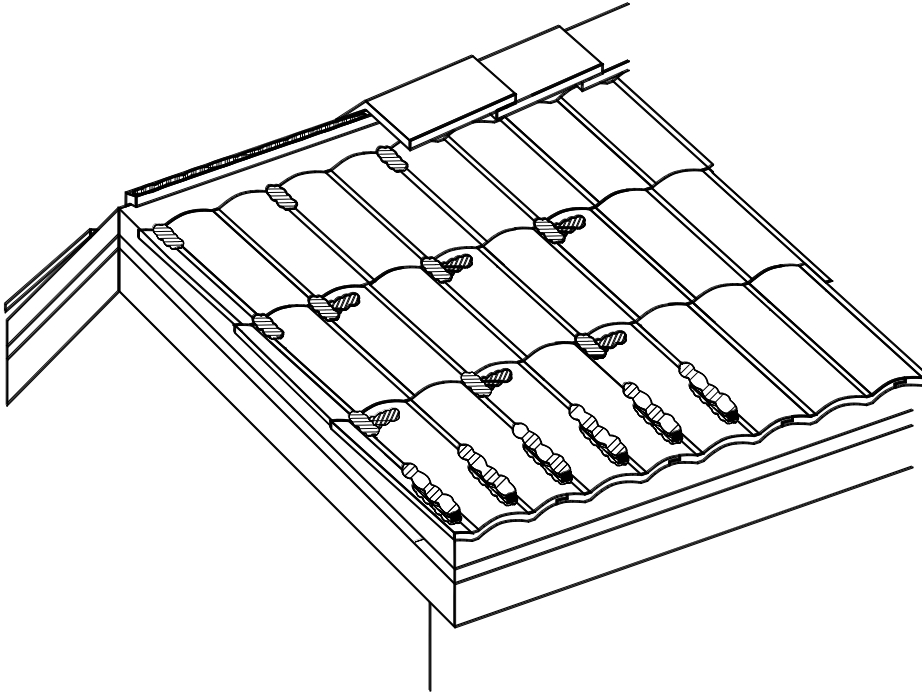

**HIGH PROFILE  
DETAIL #3**

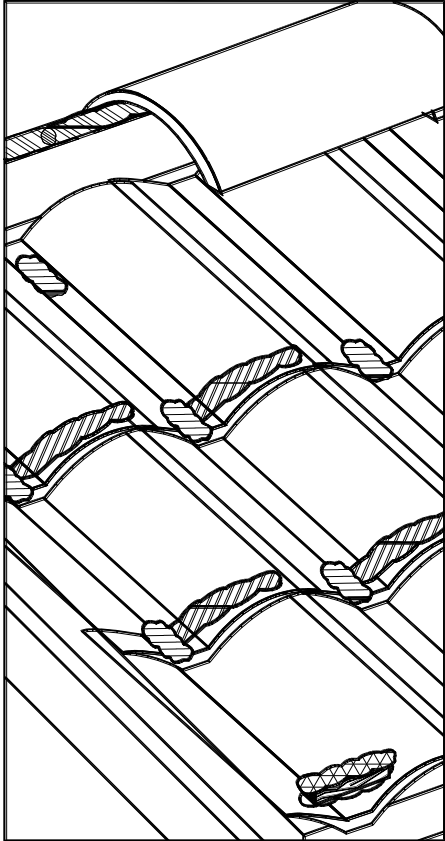
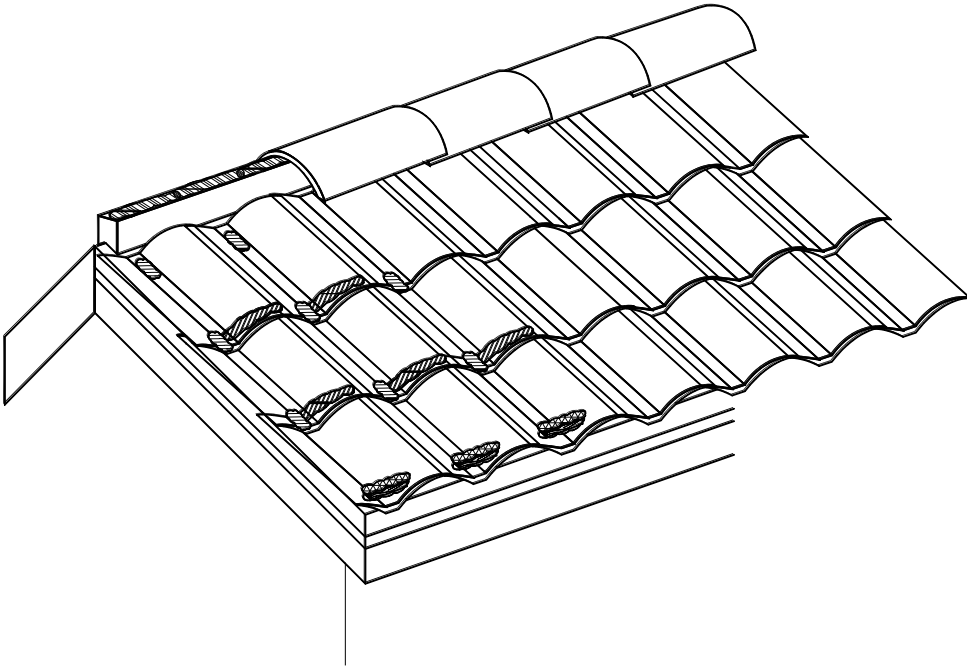



**BARREL PROFILE  
DETAIL #4**

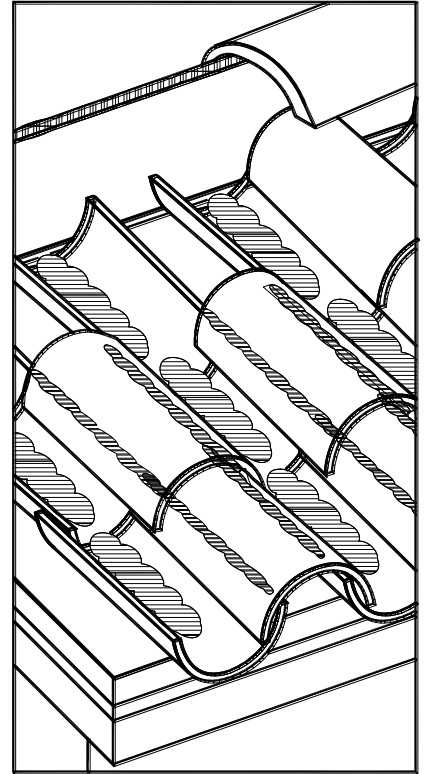
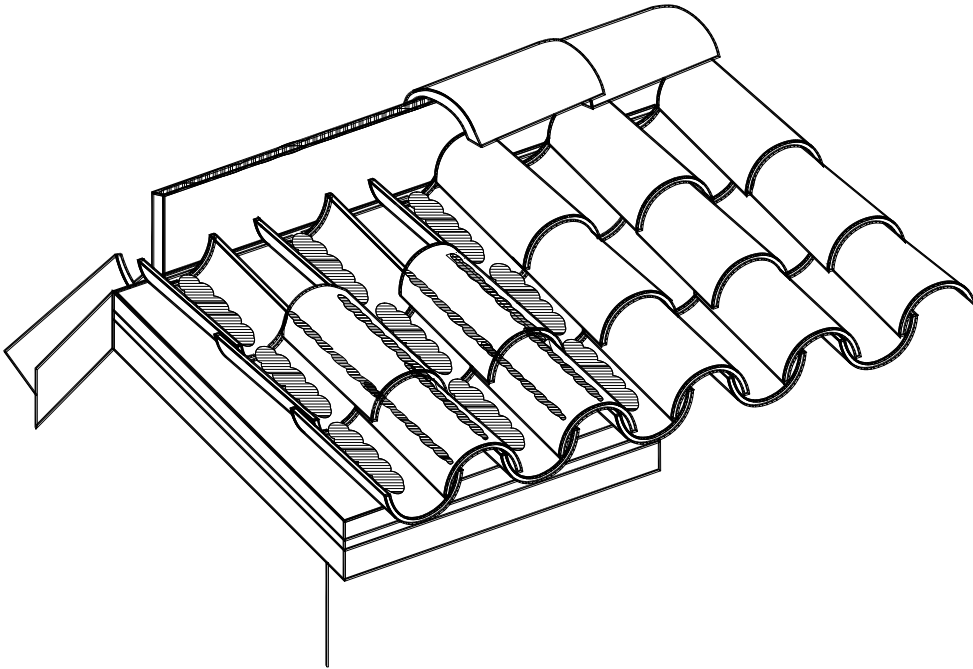

**END OF THIS ACCEPTANCE**



NOA No.: 11-0616.03  
Expiration Date: 08/23/16  
Approval Date: 08/18/11  
Page 9 of 9