



MIAMI-DADE COUNTY
BUILDING AND NEIGHBORHOOD COMPLIANCE DEPARTMENT (BNC)
BOARD AND CODE ADMINISTRATION DIVISION

MIAMI-DADE COUNTY
PRODUCT CONTROL SECTION
 11805 SW 26 Street, Room 208
 Miami, Florida 33175-2474
 T (786) 315-2590 F (786) 315-2599

www.miamidade.gov/building/home/asp

NOTICE OF ACCEPTANCE (NOA)

The Limited Edition Glassworks Inc.
51 Delta Park Blvd.
Brampton, Ontario, Canada L6T5E7

SCOPE:

This NOA is being issued under the applicable rules and regulations governing the use of construction materials. The documentation submitted has been reviewed and accepted by Miami-Dade County BNC -Product Control Section to be used in Miami Dade County and other areas where allowed by the Authority Having Jurisdiction (AHJ).

This NOA shall not be valid after the expiration date stated below. The Miami-Dade County Product Control Section (In Miami Dade County) and/or the AHJ (in areas other than Miami Dade County) reserve the right to have this product or material tested for quality assurance purposes. If this product or material fails to perform in the accepted manner, the manufacturer will incur the expense of such testing and the AHJ may immediately revoke, modify, or suspend the use of such product or material within their jurisdiction. BNC reserves the right to revoke this acceptance, if it is determined by Miami-Dade County Product Control Section that this product or material fails to meet the requirements of the applicable building code.

This product is approved as described herein, and has been designed to comply with the Florida Building Code, including the High Velocity Hurricane Zone.

DESCRIPTION: Series "PVC Lite-kit Assembly"-Component approval

APPROVAL DOCUMENT: Drawing No. **LED-LK3080 Rev #2**, titled "Impact-Resistant PVC Lite Kit Assembly" sheets 1 through 2 of 2, dated 05/02/06 and last revised on 08-24-2011, prepared by Category 5 Engineering Services, signed and sealed by Emma T. Mellinger, P.E., bearing the Miami-Dade County Product Control Renewal stamp with the Notice of Acceptance number and expiration date by the Miami-Dade County Product Control Section.

MISSILE IMPACT RATING: Large and Small Missile Impact Resistant

Limitation: This kit is to be used w/ approved Impact single glazed door system, having current NOA.

LABELING: Each unit shall bear a permanent label with the manufacturer's name or logo, Ontario, Canada and series and following statement: "Miami-Dade County Product Control Approved", unless otherwise noted herein.

RENEWAL of this NOA shall be considered after a renewal application has been filed and there has been no change in the applicable building code negatively affecting the performance of this product.

TERMINATION of this NOA will occur after the expiration date or if there has been a revision or change in the materials, use, and/or manufacture of the product or process. Misuse of this NOA as an endorsement of any product, for sales, advertising or any other purposes shall automatically terminate this NOA. Failure to comply with any section of this NOA shall be cause for termination and removal of NOA.

ADVERTISEMENT: The NOA number preceded by the words Miami-Dade County, Florida, and followed by the expiration date may be displayed in advertising literature. If any portion of the NOA is displayed, then it shall be done in its entirety.

INSPECTION: A copy of this entire NOA shall be provided to the user by the manufacturer or its distributors and shall be available for inspection at the job site at the request of the Building Official.

This NOA **renews NOA # 05-1130.01** and consists of this page 1 and evidence pages E-1, as well as approval document mentioned above.

The submitted documentation was reviewed by **Ishaq I. Chanda, P.E.**



NOA No 11-0621.06
Expiration Date: September 21, 2016
Approval Date: September 22, 2011
 Page 1

NOTICE OF ACCEPTANCE: EVIDENCE SUBMITTED

- A. DRAWINGS** (transferred from file # **05-1130.01**)
1. Manufacturer's parts drawings and sections.
 2. Drawing No. **LED-LK3080 Rev #2**, titled "Impact-Resistant PVC Lite Kit Assembly" sheets 1 through 2 of 2, dated 05/02/06 and last revised on 08-24-2011, prepared by Category 5 Engineering Services, signed and sealed by Emma T. Mellinger, P.E.
- B. TESTS** (transferred from file # **05-1130.01**)
1. Test reports on: 1) Air Infiltration Test, per FBC, TAS 202-94
2) Uniform Static Air Pressure Test, Loading per FBC TAS 202-94
3) Water Resistance Test, per FBC, TAS 202-94
4) Large Missile Impact Test per FBC, TAS 201-94
5) Cyclic Wind Pressure Loading per FBC, TAS 203-94
6) Forced Entry Test, per FBC 2411 3.2.1, TAS 202-94
- Along with marked-up drawings and installation diagram of PVC lite-kit in single operable & fixed door, prepared by Intertek ETL SEMKO, Test Report No. **3081855**, dated October 11, 2005 with addendum letter dated July 17, 2006, signed and sealed by Stephen Emerman, P.E.
2. Test report No. **3081855** on fasteners "pull out" test per ASTM D-1761 dated 09-29-05, issued by Intertek ETL SEMKO.
- C. CALCULATIONS**
1. Statement letter of conformance dated June 13, 2011 to FBC 2007, issued by Category 5 Engineering Services, signed and sealed by Emma T. Mellinger, P.E.
 2. Anchor verification calculation dated 04/11/06, prepared by Category 5 Engineering Services, signed and sealed by Emma T. Mellinger, P.E. (transferred from file # **05-1130.01**)
 3. Glazing complies w/ ASTM E-1300-02 & -04
- D. QUALITY ASSURANCE**
1. Miami Dade Building and Neighborhood Compliance Department (BNC).
- E. MATERIAL CERTIFICATIONS**
1. Notice of Acceptance No #**10-0420.06** issued to Vision Extrusion Ltd., for their "White Rigid PVC Extrusion", expiring on 09/30/14.
- F. STATEMENTS**
1. Statement letter of conformance and letter of no financial interest dated June 13, 2011, prepared by Category 5 Engineering Services, signed & sealed by Emma T. Mellinger, P.E.
 2. Distributor agreement dated August 15, 2011 between the Vision Extrusion Limited, Canada and The Limited Edition Glassworks Inc. Canada, signed by Tony Villa and Gerry Rizzardo, respectively on behalf of their company.
 3. Statement of lab compliance, as part of above referenced test reports.
- G. OTHER**
1. This NOA **renews** NOA # **05-1130.01**, expiring on Sep. 21, 2011.
 2. Test Proposal No. **05-0103**, approved by BCCO on May 13, 2005.

Ishaq I. Chanda

Ishaq I. Chanda, P.E.
Product Control Examiner
NOA No 11-0621.06

Expiration Date: September 21, 2016
Approval Date: September 22, 2011

THE LIMITED EDITION GLASSWORKS, INC.

51 Delta Park Blvd., Brampton, ON L6T 5E7 Canada
Tel: (905) 791-8200 Fax: (905) 791-1545

GENERAL NOTES AND LIMITATIONS

2 This Product Has Been Designed To Comply With the HVHZ Requirements of the 2007 Florida Building Code.

In Windborne Debris Regions, Hurricane Shutters SHALL NOT be Required When This Product is Used In Conjunction With a Miami-Dade County Approved Large Missile Impact Resistant Door Panel Meeting the Specifications Below.

Glazing Options are Shown on Sheet 2

LIMITATIONS

This Impact-Tested Lite Kit Assembly (as a Component) is to be used as a Substitute to a Similar Assembly in an Impact-Tested Single Glazed Door System of Same or Superior Construction Holding a Current Miami-Dade County Notice of Acceptance.

The Lower Design Pressure of This Product, or the Approved Impact-Tested Door System Shall Control.

This Product SHALL NOT be Used or Approved With an Opaque Door System NOA.

SPECIFICATIONS FOR ACCEPTABLE DOOR PANELS

Impact-Tested Door System Shall Hold a Current Miami-Dade County NOA, and Meet The Minimum Requirements Listed Below to be Used With This Component Approval.

1. Single-Glazed Fixed, Single-Glazed Outswinging, or Single-Glazed Inswinging (Swinging Doors Require (2) Surface Bolts on Active Panel).
2. Maximum Nom. Panel Size: 36" x 96".
3. Minimum Panel Thickness: 1 3/4".
4. Interior Filled with Rigid Polyurethane Foam Complying With FBC Plastics Requirements.
5. Steel- or Fiberglass-Clad as Follows:

FIBERGLASS DOOR PANELS

2 Skin: 0.075" Min. Thick Fiberglass (Fy Min = 5,403 psi. after Weathering Test per Section 2612 of 2007 FBC).
Rails: 0.96875" Wood Composite.
Stiles: 1.625" Laminated Lumber.

STEEL DOOR PANELS

Skin: Minimum 26 Gauge (0.017") Steel w/Fy Min = 43,270 psi.
Edges: Wood, Wood-Composite (Min. 3/32" Top & Bottom Rails, or Roll-Formed Steel).

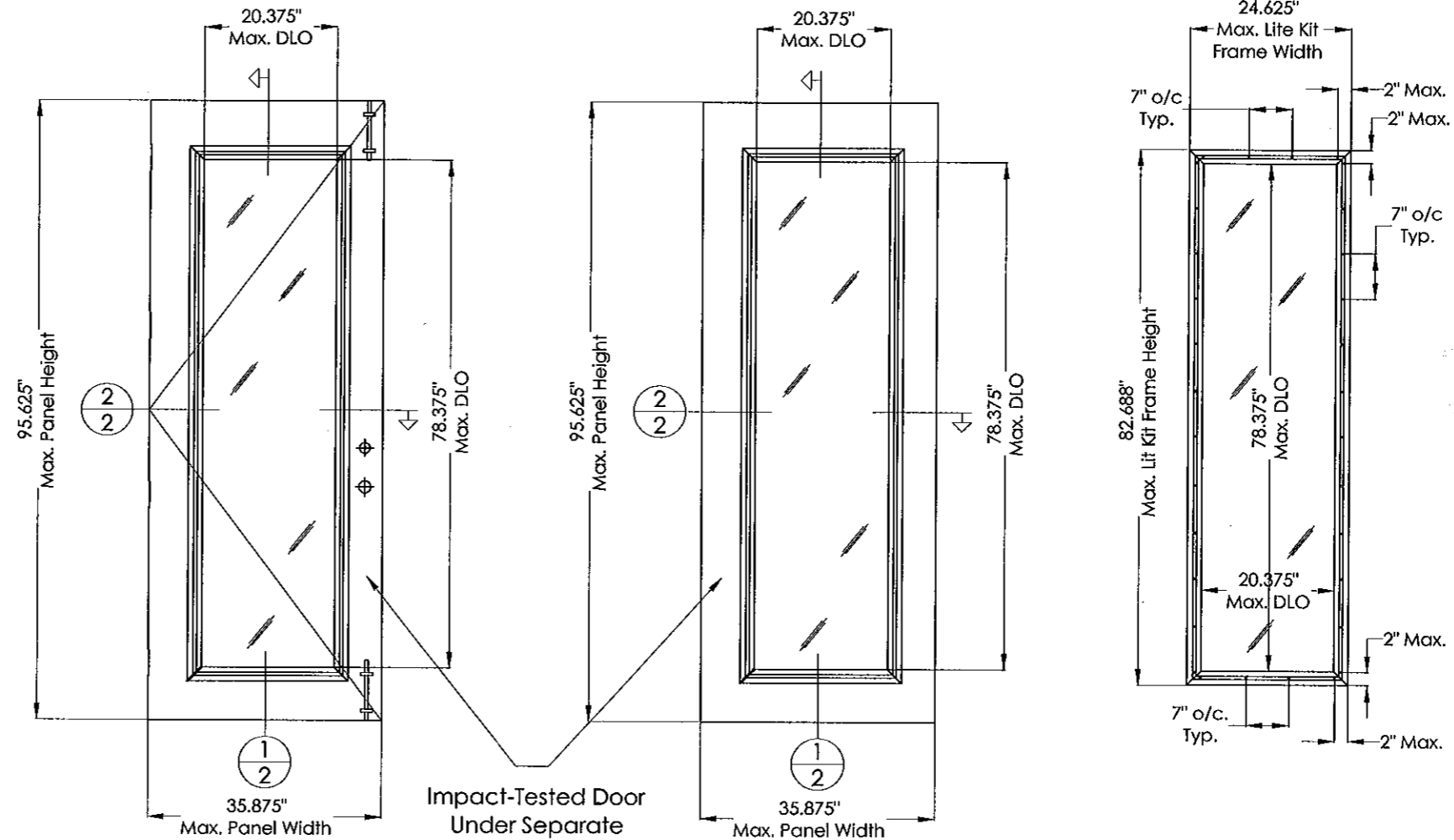

**SINGLE-GLAZED
SWINGING DOOR PANEL**

(2) Surface Bolts on Active Panel

FIXED DOOR PANEL

**LIMITED EDITION
GLASSWORKS
LITE KIT ONLY**

LITE-KIT DESIGN PRESSURE RATING
(All Configurations Shown)

+60 psf

-60 psf

PRODUCT RENEWED
as compliant with the Florida
Building Code
Assessment No 11-0621-06
Expiration Date SEP 21, 2016
By: [Signature]
Miami-Dade Product Control

CATEGORY 5
Engineering Services

1600 S. Federal Highway, #207
Pompano Beach, FL 33062
(954) 784-6991; (954) 781-5708 Fax

EMMA T. MELLINGER, P.E.
FL PE #50049
CA #25854
8/24/11

**IMPACT-RESISTANT PVC LITE-KIT
ASSEMBLY (Component Approval)**

The Limited Edition Glassworks, Inc.

**ELEVATIONS and
SPECIFICATIONS**

ORIG. DATE: 05 / 02 / 06	SCALE: AS NOTED	BY: ETM	REVISIONS	NO.	DATE	BY	DESCRIPTION
				2	06-13-11	EM	Ref. 2007 FBC
				1	08-21-06	EM	Per M-D BCCO

DRAWING No. :
LED-LK3080 R2

1 VERTICAL CROSS SECTION
2

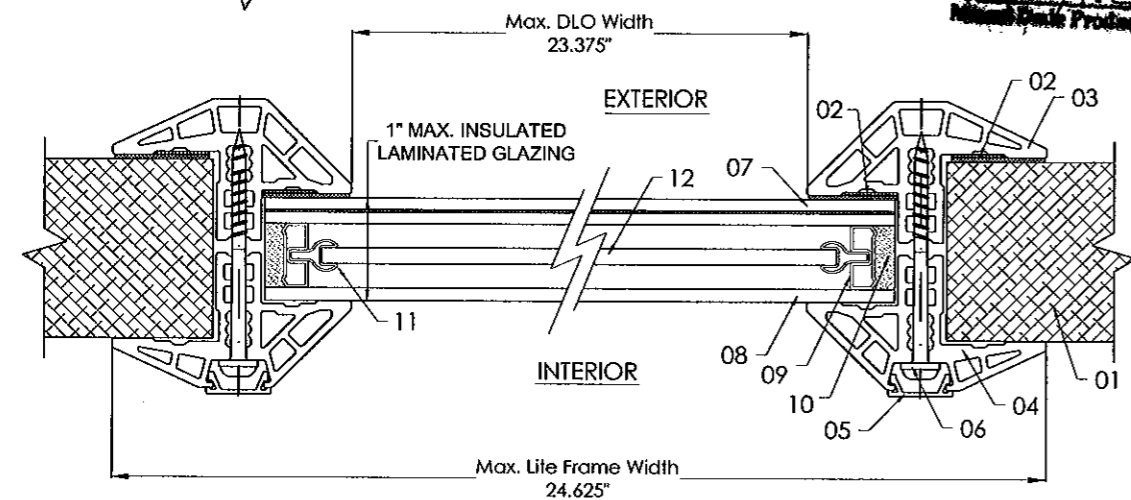
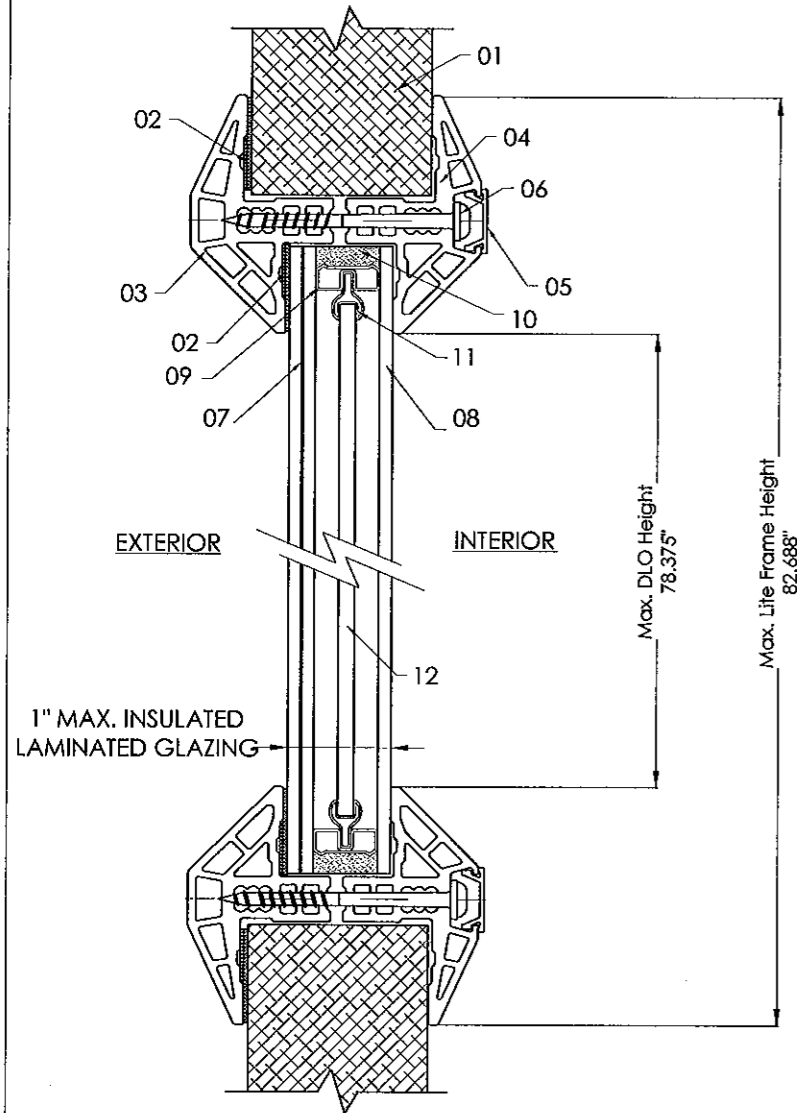

2 HORIZONTAL CROSS SECTION
2

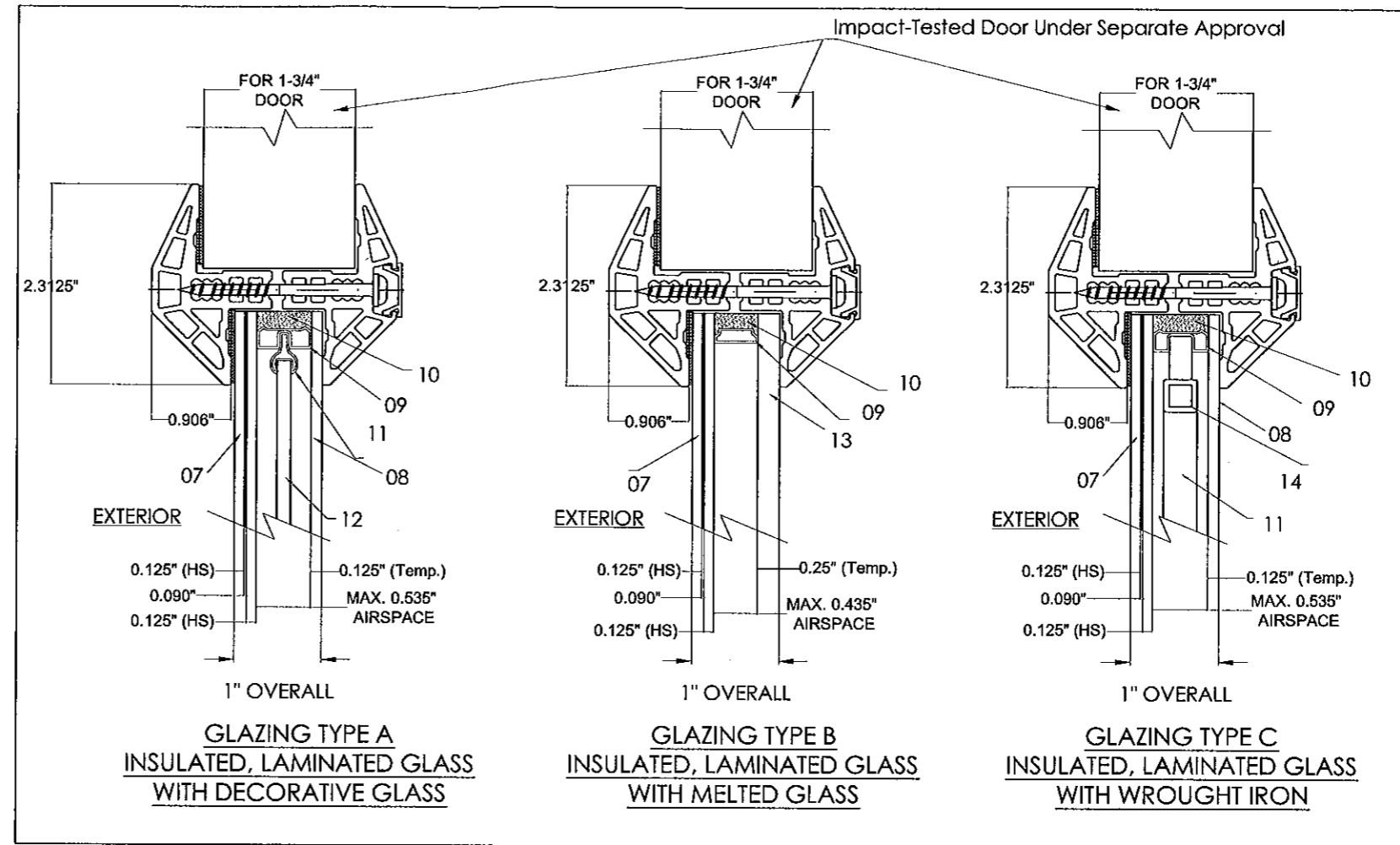

PRODUCT RENEWED
as complying with the Florida
Building Code
Acceptance No 11-0621.06
Expiration Date SEP 21, 2016
By Susan L. Chandra
Miami-Dade Product Council

BILL OF MATERIALS

#	Description	Material	Type	Dimensions	Note
01	Miami-Dade Product Approved Impact-Tested Door ¹			1.75" x 36" x 96"	See Specs on Sheet 1
02	Double Coated Tape	Acrylic	3M VHB 4941	0.09" x .75"	L = 408"
03	External Frame	White PVC ³		1.375" x 2.125"	Vision Extrusions, Ltd
04	Internal Frame	White PVC ³		1.3125" x 23.125"	Vision Extrusions, Ltd
05	Cover for Internal Frame	White PVC ³		0.222" x 0.625"	Vision Extrusions, Ltd
06	Deep Threaded Screw	Steel	Flanged Panhead	# 8 x 2.25"	2" From Corners, 7" o/c.
07	Laminated Glass ² (Part of Overall Insulated Glass)			5/16" x 22" x 80"	Guardian
08	Nom 1/8" Tempered Glass (Part of Overall Insulated Glass)			1/8" x 22" x 80"	Guardian
09	Door Lite Spacer	Aluminum	DRL 125		RPM Rollforming
10	Two Component Sealant	Polysulphide	Thiover		Fenzi
11	Y - Caming Profile	Brass / Zinc	BY-916 CAMEN		RPM Rollforming
12	Decorative Glass Panel				Limited Edition
13	1/4" Tempered Melted Glass (Part of Overall Insulated Glass)			1/4" x 22" x 80"	Guardian
14	Wrought Iron Panel				Limited Edition

¹- Refer to Sheet 1 For Specifications For Acceptable Door Panels
²- Insulated Laminated Glass - (2) Lites of Nom. 1/8" HS Glass with 0.090" Interlayer by Either SOLUTIA (With Current NOA), or DUPONT PVB (With Current NOA).

³- Extrusion to be Labeled with AAMA's PVC Extrusion Certification Label, "MDCA" and Extrusion Number.

CATEGORY 5
Engineering Services

1600 S. Federal Highway, #207
Pompano Beach, FL 33062
(954) 784-6991; (954) 781-5708 Fax

EM
8/24/11

Emma J. Mellinger, P.E.
FL PE #50049
CA #25854

IMPACT-RESISTANT PVC LITE-KIT ASSEMBLY (Component Approval)
The Limited Edition Glassworks, Inc.

SECTIONS and BILL OF MATERIALS

ORIG. DATE: 05/02/06

SCALE: AS NOTED

BY: ETM

REVISIONS

NO.	DATE	BY	DESCRIPTION
2	06-13-11	EM	Ref. 2007 FBC
1	08-21-06	EM	Per M-D BCCO

DRAWING No. :
LED-LK3080 R2

Sheet 2 of 2