



BUILDING AND NEIGHBORHOOD COMPLIANCE DEPARTMENT (BNC)
BOARD AND CODE ADMINISTRATION DIVISION

MIAMI-DADE COUNTY
PRODUCT CONTROL SECTION
11805 SW 26 Street, Room 208
Miami, Florida 33175-2474
T (786) 315-2590 F (786) 315-2599
www.miamidade.gov/building/

NOTICE OF ACCEPTANCE (NOA)

Monier Lifetile, LLC
200 Story Road
Lake Wales, FL 33853

SCOPE:

This NOA is being issued under the applicable rules and regulations governing the use of construction materials. The documentation submitted has been reviewed and accepted by Miami-Dade County BNC - Product Control Section to be used in Miami Dade County and other areas where allowed by the Authority Having Jurisdiction (AHJ).

This NOA shall not be valid after the expiration date stated below. The Miami-Dade County Product Control Section (In Miami Dade County) and/or the AHJ (in areas other than Miami Dade County) reserve the right to have this product or material tested for quality assurance purposes. If this product or material fails to perform in the accepted manner, the manufacturer will incur the expense of such testing and the AHJ may immediately revoke, modify, or suspend the use of such product or material within their jurisdiction. BNC reserves the right to revoke this acceptance, if it is determined by Miami-Dade County Product Control Section that this product or material fails to meet the requirements of the applicable building code.

This product is approved as described herein, and has been designed to comply with the Florida Building Code including the High Velocity Hurricane Zone of the Florida Building Code.

DESCRIPTION: Villa 900 Concrete Roof Tile

LABELING: Each unit shall bear a permanent label with the manufacturer's name or logo, city, state and following statement: "Miami-Dade County Product Control Approved", unless otherwise noted herein.

RENEWAL of this NOA shall be considered after a renewal application has been filed and there has been no change in the applicable building code negatively affecting the performance of this product.

TERMINATION of this NOA will occur after the expiration date or if there has been a revision or change in the materials, use, and/or manufacture of the product or process. Misuse of this NOA as an endorsement of any product, for sales, advertising or any other purposes shall automatically terminate this NOA. Failure to comply with any section of this NOA shall be cause for termination and removal of NOA.

ADVERTISEMENT: The NOA number preceded by the words Miami-Dade County, Florida, and followed by the expiration date may be displayed in advertising literature. If any portion of the NOA is displayed, then it shall be done in its entirety.

INSPECTION: A copy of this entire NOA shall be provided to the user by the manufacturer or its distributors and shall be available for inspection at the job site at the request of the Building Official.

This renews NOA# 06-0524.02 and consists of pages 1 through 7.
The submitted documentation was reviewed by Alex Tigera.



NOA No.: 11-0713.02
Expiration Date: 09/21/16
Approval Date: 09/08/11
Page 1 of 7

ROOFING ASSEMBLY APPROVAL

Category: Roofing
Sub Category: Low Profile Roofing Tiles
Material: Concrete

1. SCOPE

This renews a system using Monier Lifetile Villa 900 Concrete Roof Tile, as manufactured Monier Lifetile LLC in Lake Wales, FL. and described in Section 2 of this Notice of Acceptance. For locations where the pressure requirements, as determined by applicable Building Code does not exceed the design pressure values obtained by calculations in compliance with RAS 127 using the values listed in section 4 herein. The attachment calculations shall be done as a moment based system.

2. PRODUCT DESCRIPTION

<u>Manufactured by Applicant</u>	<u>Dimensions</u>	<u>Test Specifications</u>	<u>Product Description</u>
Monier Lifetile LLC Villa 900	l = 17" w = 13" ½" thick	TAS 112	Low profile, interlocking, high pressure extruded concrete roof tile equipped with one nail hole and double roll ribs. For direct deck or battened nail-on, mortar or adhesive set applications.
Trim Pieces	l = varies w = varies varying thickness	TAS 112	Accessory trim, concrete roof pieces for use at hips, rakes, ridges and valley terminations.

2.1 MANUFACTURING LOCATION

2.1.1. Lake Wales, FL.

2.2 EVIDENCE SUBMITTED

<u>Test Agency</u>	<u>Test Identifier</u>	<u>Test Name/Report</u>	<u>Date</u>
Nutting Engineers	13343.1	TAS 112	Apr. 2006
Redland Technologies	7161-03 Appendix III	Static Uplift Testing TAS 102 & TAS 102(A)	Dec. 1991
Redland Technologies	7161-03 Appendix II	Wind Tunnel Testing TAS 108 (Nail-On)	Dec. 1991
Redland Technologies	P0402	Withdrawal Resistance Testing of screw vs. smooth shank nails	Sept. 1993
The Center for Applied Engineering, Inc.	94-060B	Static Uplift Testing TAS 101 (Adhesive Set)	March, 1994
The Center for Applied Engineering, Inc.	94-084	Static Uplift Testing TAS 101 (Mortar Set)	May 1994

<u>Test Agency</u>	<u>Test Identifier</u>	<u>Test Name/Report</u>	<u>Date</u>
Redland Technologies	P0631-01	Wind Tunnel Testing TAS 108 (Mortar Set)	July 1994
Redland Technologies	Letter Dated Aug. 1, 1994	Wind Tunnel Testing TAS 108 (Nail-On)	Aug. 1994
The Center for Applied Engineering, Inc.	Project No. 307025 Test #MDC-76	Wind Driven Rain TAS 100	Oct. 1994
The Center for Applied Engineering, Inc.	25-7183-1	Static Uplift Testing TAS 102 (2 Quik-Drive Screws, Direct Deck)	Feb. 1995
The Center for Applied Engineering, Inc.	25-7183-2	Static Uplift Testing TAS 102 (2 Quik-Drive Screws, Battens)	Feb. 1995
The Center for Applied Engineering, Inc.	25-7214-2 25-7214-6	Static Uplift Testing TAS 102 (1 Quik-Drive Screw, Direct Deck) (1 Quik-Drive Screw, Battens)	March, 1995
Celotex Corporation Testing Services	528454-2-1 520109-2	Static Uplift Testing TAS 101	Sep. 1998 Dec. 1998
Walker Engineering, Inc.	Evaluation Calculations	25-7183	March 1995
Walker Engineering, Inc.	Evaluation Calculations	25-7094	February 1996
Walker Engineering, Inc.	Evaluation Calculations	25-7496	April 1996
Walker Engineering, Inc.	Evaluation Calculations	25-7584 25-7804b-8 25-7804-4 & 5 25-7848-6	December 1996
Walker Engineering, Inc.	Evaluation Calculations	Aerodynamic Multipliers	May 2006
Walker Engineering, Inc.	Evaluation Calculations	Two Patty Adhesive Set System	April 1999
Walker Engineering, Inc.	Evaluation Calculations	Restoring Moment Due to Gravity	April 2006



3. LIMITATIONS:

- 3.1 Fire classification is not part of this acceptance.
- 3.2 For mortar or adhesive set tile applications, a static field uplift test shall be performed in accordance with TAS 106.
- 3.3 Applicant shall retain the services of a Miami-Dade County Certified Laboratory to perform quarterly test in accordance with TAS 112, appendix 'A'. Such testing shall be submitted to the Building Code Compliance Office for review.
- 3.4 Minimum underlayment shall be in compliance with the applicable Roofing Applications Standards listed section 4.1 herein.
- 3.5 30/90 hot mopped underlayment applications may be installed perpendicular to the roof slope unless stated otherwise by the underlayment material manufacturers published literature.
- 3.6 This acceptance is for wood deck applications. Minimum deck requirements shall be in compliance with applicable building code.

4. INSTALLATION

- 4.1 Monier Lifetile Villa 900 Concrete Roof Tile and its components shall be installed in strict compliance with Roofing Application Standard RAS 118, RAS 119, and RAS 120.
- 4.2 Data For Attachment Calculations

Table 1: Average Weight (W) and Dimensions (l x w)			
Tile Profile	Weight-W (lbf)	Length-l (ft)	Width-w (ft)
Monier Lifetile Villa 900 Concrete Tile	10.94	1.425	1.08

Table 2: Aerodynamic Multipliers - λ (ft ³)		
Tile Profile	λ (ft ³) Batten Application	λ (ft ³) Direct Deck Application
Monier Lifetile Villa 900 Concrete Tile	0.289	0.289

Table 3: Restoring Moments due to Gravity - M_q (ft-lbf)										
Tile Profile	3":12"		4":12"		5":12"		6":12"		7":12" or greater	
	Battens	Direct Deck	Battens	Direct Deck	Battens	Direct Deck	Battens	Direct Deck	Battens	Direct Deck
Monier Lifetile Villa 900 Concrete Tile	6.79	7.70	6.73	7.62	6.63	7.51	6.50	7.37	6.36	7.21



Table 4: Attachment Resistance Expressed as a Moment - M_f (ft-lbf) for Nail-On Systems				
Tile Profile	Fastener Type	Direct Deck (min 15/32" plywood)	Direct Deck (min. 19/32" plywood)	Battens
Monier Lifetile Villa 900 Concrete Tile	2-10d Ring Shank Nails	27.8	37.4	28.8
	1-10d Smooth or Screw Shank Nail	8.8	11.8	4.1
	2-10d Smooth or Screw Shank Nails	16.4	21.9	7.1
	1 #8 Screw	25.8	25.8	22.9
	2 #8 Screw	47.1	47.1	49.1
	1-10d Smooth or Screw Shank Nail (Field Clip)	24.3	24.3	24.2
	1-10d Smooth or Screw Shank Nail (Eave Clip)	19.0	19.0	22.1
	2-10d Smooth or Screw Shank Nails (Field Clip)	35.5	35.5	34.8
	2-10d Smooth or Screw Shank Nails (Eave Clip)	31.9	31.9	32.2

Table 5: Attachment Resistance Expressed as a Moment M_f (ft-lbf) for Two Patty Adhesive Set Systems		
Tile Profile	Tile Application	Minimum Attachment Resistance
Monier Lifetile Villa 900 Concrete Tile	Adhesive ¹	26.1 ²
¹ See manufactures component approval for installation requirements. ² Flexible Products Company TileBond Average weight per patty 11.4 grams. Polyfoam Product, Inc. Average weight per patty 8 grams.		

Table 6: Attachment Resistance Expressed as a Moment - M_f (ft-lbf) for Single Patty Adhesive Set Systems		
Tile Profile	Tile Application	Minimum Attachment Resistance
Monier Lifetile Villa 900 Concrete Tile	Polyfoam PolyPro™	86.61 ³
	Polyfoam PolyPro™	45.5 ⁴
³ Large paddy placement of 54grams of PolyPro™. ⁴ Medium paddy placement of 24grams of PolyPro™.		

Table 7: Attachment Resistance Expressed as a Moment - M_f (ft-lbf) for Mortar Set Systems		
Tile Profile	Tile Application	Attachment Resistance
Monier Lifetile Villa 900 Concrete Tile	Mortar Set ⁵	20.60
⁵ See specific mortar manufacturer's Notice of Acceptance		



5. LABELING

- 5.1 All tiles shall bear the imprint or identifiable marking of the manufacturer's name or logo as detailed below, or following statement: "Miami-Dade County Product Control Approved".

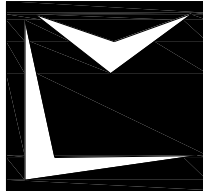

**LABEL FOR VILLA 900 CONCRETE TILE
(LOCATED ON THE UNDERSIDE OF TILE)**

6. BUILDING PERMIT REQUIREMENTS:

- 6.1 Application for building permit shall be accompanied by copies of the following:
- 6.1.1 This Notice of Acceptance.
 - 6.1.2 Any other documents required by Building Official or Applicable building code in order to properly evaluate the installation of this system.



PROFILE DRAWING

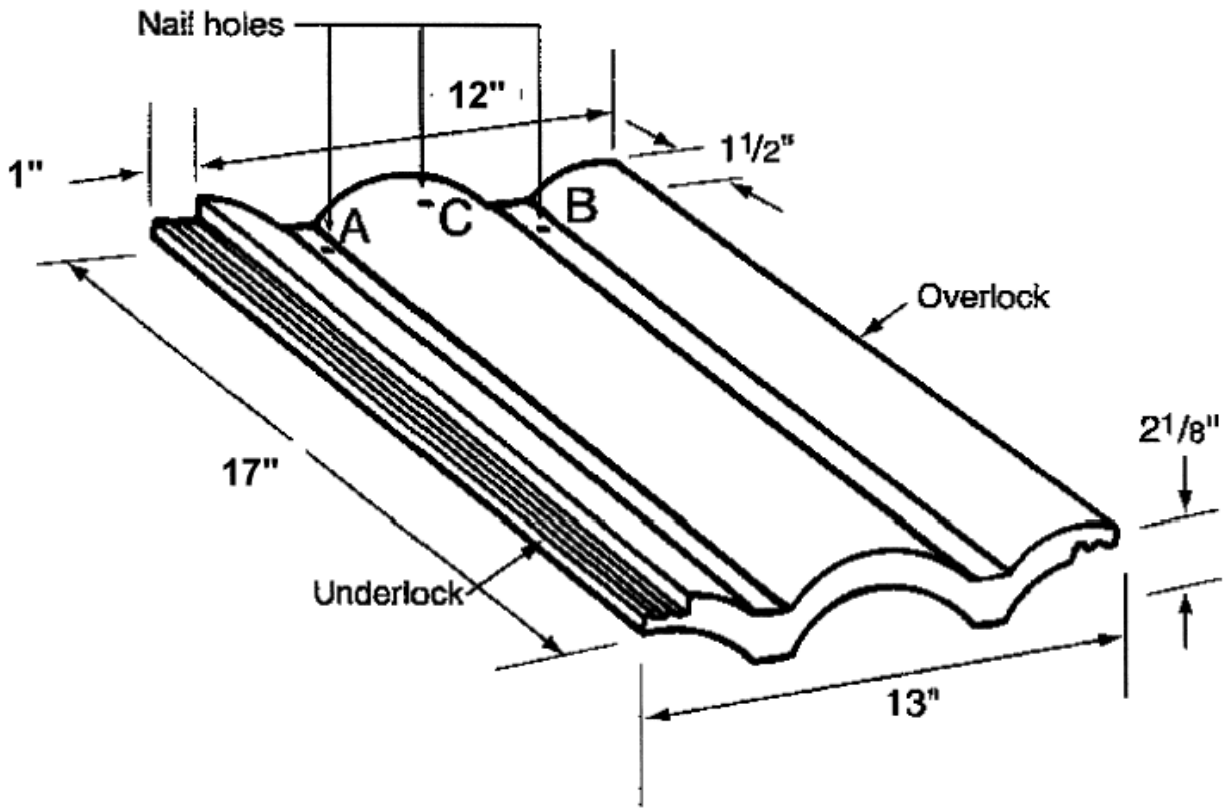

MONIER LIFETILE VILLA 900 CONCRETE ROOF TILE

END OF THIS ACCEPTANCE



NOA No.: 11-0713.02
Expiration Date: 09/21/16
Approval Date: 09/08/11
Page 7 of 7