



BUILDING AND NEIGHBORHOOD COMPLIANCE DEPARTMENT (BNC)
BOARD AND CODE ADMINISTRATION DIVISION

MIAMI-DADE COUNTY
PRODUCT CONTROL SECTION
11805 SW 26 Street, Room 208
Miami, Florida 33175-2474
T (786) 315-2590 F (786) 315-2599
www.miamidade.gov/building/

NOTICE OF ACCEPTANCE (NOA)

Bermuda Roof Co., Inc.
10709 SF Flotilla Court
Hobe sound, FL. 33455

SCOPE:

This NOA is being issued under the applicable rules and regulations governing the use of construction materials. The documentation submitted has been reviewed and accepted by Miami-Dade County BNC - Product Control Section to be used in Miami Dade County and other areas where allowed by the Authority Having Jurisdiction (AHJ).

This NOA shall not be valid after the expiration date stated below. The Miami-Dade County Product Control Section (In Miami Dade County) and/or the AHJ (in areas other than Miami Dade County) reserve the right to have this product or material tested for quality assurance purposes. If this product or material fails to perform in the accepted manner, the manufacturer will incur the expense of such testing and the AHJ may immediately revoke, modify, or suspend the use of such product or material within their jurisdiction. BNC reserves the right to revoke this acceptance, if it is determined by Miami-Dade County Product Control Section that this product or material fails to meet the requirements of the applicable building code.

This product is approved as described herein, and has been designed to comply with the Florida Building Code including the High Velocity Hurricane Zone of the Florida Building Code.

DESCRIPTION: Lightweight Roof Tile Mortar

LABELING: Each unit shall bear a permanent label with the manufacturer's name or logo, city, state and following statement: "Miami-Dade County Product Control Approved", unless otherwise noted herein.

RENEWAL of this NOA shall be considered after a renewal application has been filed and there has been no change in the applicable building code negatively affecting the performance of this product.

TERMINATION of this NOA will occur after the expiration date or if there has been a revision or change in the materials, use, and/or manufacture of the product or process. Misuse of this NOA as an endorsement of any product, for sales, advertising or any other purposes shall automatically terminate this NOA. Failure to comply with any section of this NOA shall be cause for termination and removal of NOA.

ADVERTISEMENT: The NOA number preceded by the words Miami-Dade County, Florida, and followed by the expiration date may be displayed in advertising literature. If any portion of the NOA is displayed, then it shall be done in its entirety.

INSPECTION: A copy of this entire NOA shall be provided to the user by the manufacturer or its distributors and shall be available for inspection at the job site at the request of the Building Official.

This renews NOA# 06-0329.05 and consists of pages 1 through 7.
The submitted documentation was reviewed by Alex Tigera.



NOA No.: 11-0816.05
Expiration Date: 09/20/16
Approval Date: 09/15/11
Page 1 of 7

ROOFING COMPONENT APPROVAL:

Category: Roofing
Sub-Category: Roof Tile Adhesives
Material: Cement

SCOPE:

This renews “Tile-Tite” Roof Tile Mortar, as manufactured by Bermuda Roof Company, Inc. as described in this Notice of Acceptance, and designed to comply with the High Velocity Hurricane Zone of the Florida Building Code.

PRODUCT DESCRIPTION:

<u>Manufactured by Applicant</u>	<u>Dimensions</u>	<u>Product Description</u>
“Tile Tite”Roof Tile Mortar	N/A	Premixed prebagged roof tile mortar for used with approved roof tile in accordance with RAS 120

MANUFACTURING LOCATION:

1. Winter Springs, FL..

EVIDENCE SUBMITTED:

<u>Test Agency</u>	<u>Test Identifier</u>	<u>Test Name/Report</u>	<u>Date</u>
Center for Applied Engineering, Inc.	#94-084	TAS 101	04/08/94
Florida Testing and Engineering, Inc.	#450225	ASTM C9 Type M	05/10/94
PRI Asphalt Technologies	BRCI-001-02-01	TAS 123/TAS 101	03/14/06

LIMITATIONS:

1. Fire classification is not part of this acceptance.
2. Field uplift testing shall be performed, in compliance with the test procedure set forth in RAS 106. Testing shall be performed not prior to 30 days after installation.
3. “Tile-Tite” Roof Tile Mortar shall be placed in accordance with the 'Placement Details' provided herein. Each generic tile profile requires a specific placement, (see Placement Detail listed herein).
4. “Tile-Tite” Roof Tile Mortar shall be applied in accordance with Bermuda Roof Specifications.
5. Tile must be applied within 5 minutes of the application of “Tile-Tite’ Roof Tile Mortar.
6. Refer to RAS 120, for penetrations and terminations, as well as the 'Placement Details' herein.
7. Refer to Tile manufacturer's Product Control Notice of Acceptance for system approvals.



INSTALLATION:

- 1. "Tile-Tite" Roof Tile Mortar and its components shall be installed in strict compliance with RAS 120.
- 2. Placement Details:

Adhesive Placement:

GENERIC PROFILE:	PLACEMENT DETAIL #
Two piece Barrel	A
Spanish & Mission "S"	B
Low Profile Roll	C
Flat	D

LABELING:

All bags shall be labeled in accordance with the Standard Conditions herein.

BUILDING PERMIT REQUIREMENTS:

Any documents required by the Building Official or applicable building code in order to properly evaluate the installation of this system.



PLACEMENT DETAIL "A"

TILE & MORTAR PLACEMENT - BARREL TILE - 2 PC.

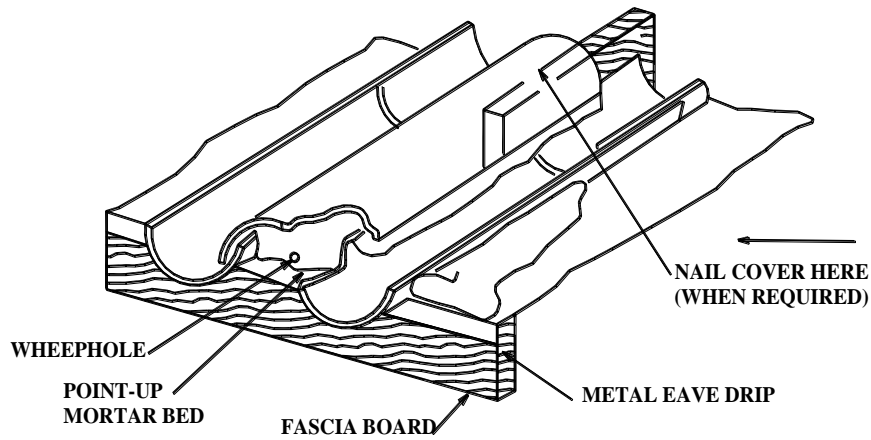
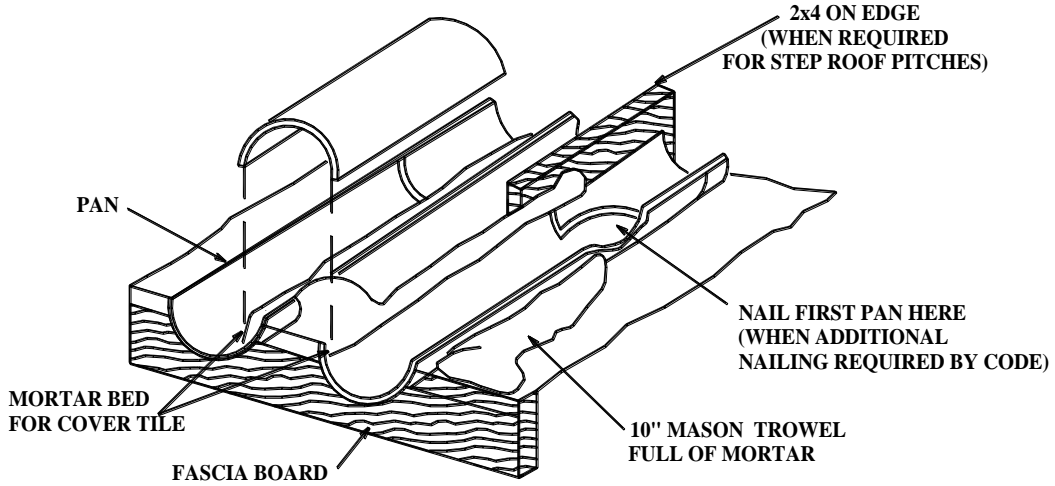

PLACEMENT DETAIL "B"

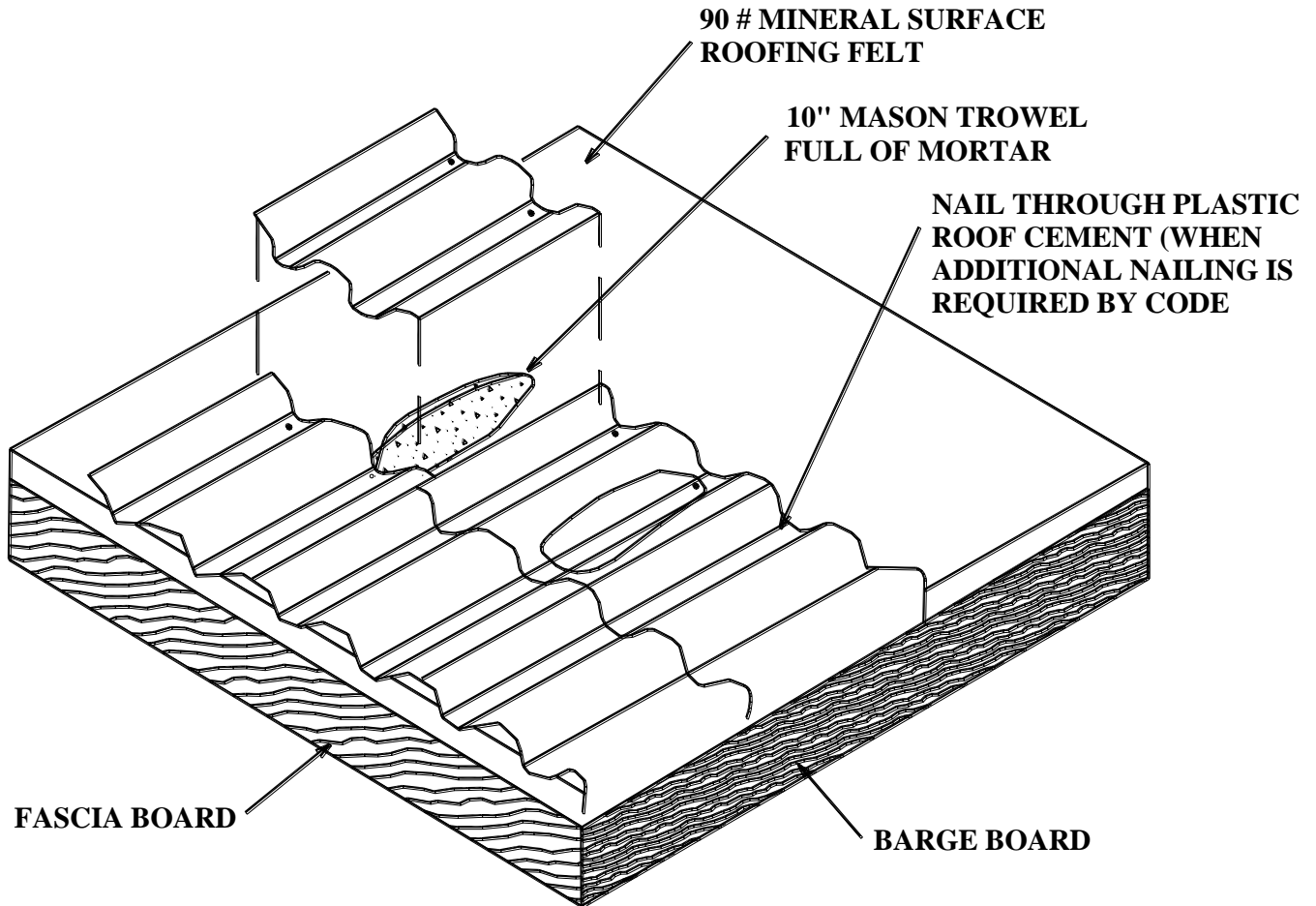

PLACEMENT DETAIL "C"

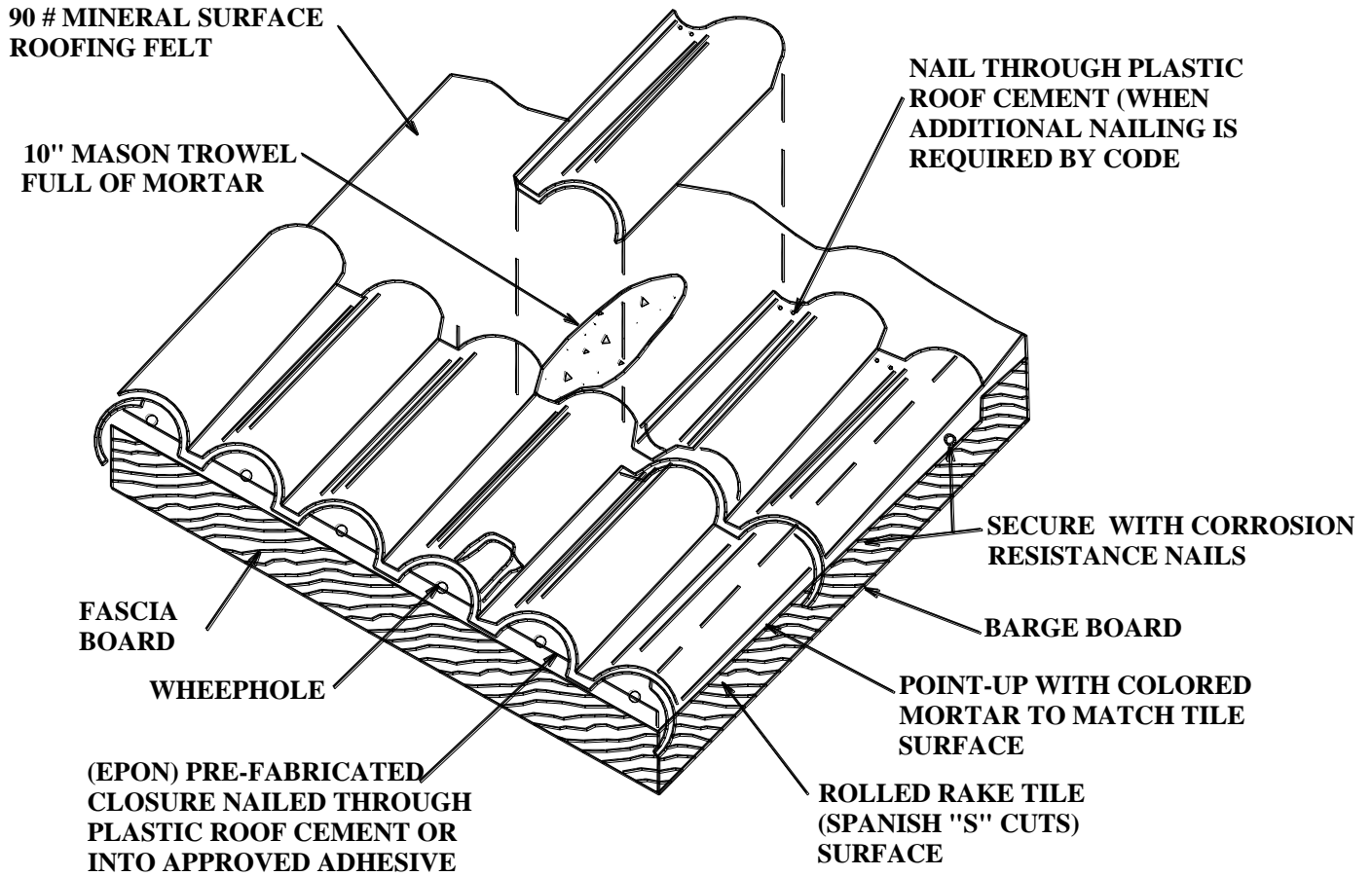

PLACEMENT DETAIL "D"

NOTE: MORTAR SHALL NOT REACH INTO THE HEAD OF TILE IN PREVIOUS COURSE OR INTO UNDERLOCK OF ADJACENT TILE.

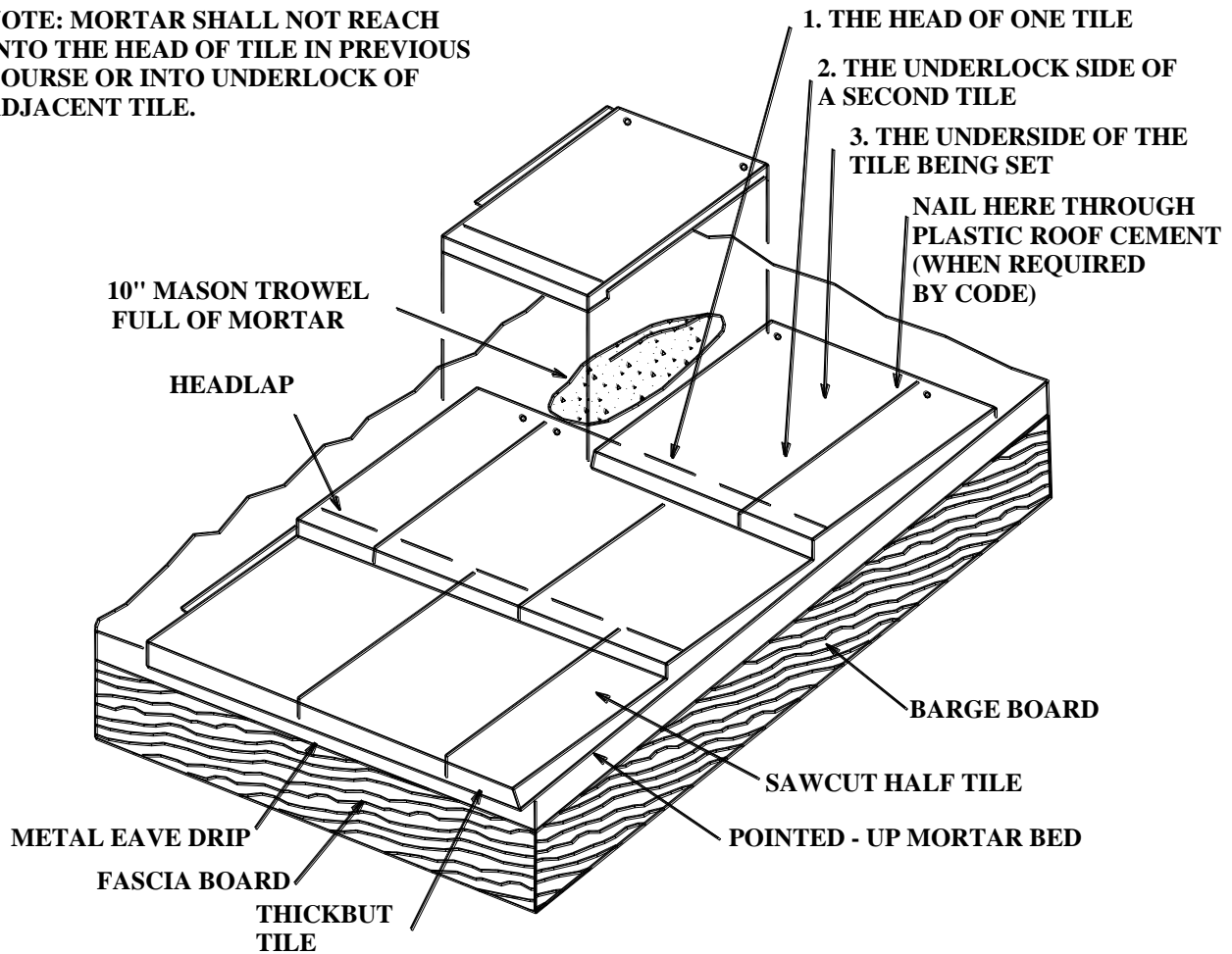

END OF THIS ACCEPTANCE



NOA No.: 11-0816.05
Expiration Date: 09/20/16
Approval Date: 09/15/11
Page 7 of 7