



DEPARTMENT OF PERMITTING, ENVIRONMENT, AND REGULATORY AFFAIRS (PERA)
BOARD AND CODE ADMINISTRATION DIVISION

MIAMI-DADE COUNTY
PRODUCT CONTROL SECTION
11805 SW 26 Street, Room 208
Miami, Florida 33175-2474
T (786) 315-2590 F (786) 315-2599
www.miamidade.gov/pera

NOTICE OF ACCEPTANCE (NOA)

CertainTeed Corporation
1400 Union Meeting Road
Blue Bell, PA 19422

SCOPE:

This NOA is being issued under the applicable rules and regulations governing the use of construction materials. The documentation submitted has been reviewed and accepted by Miami-Dade County PERA - Product Control Section to be used in Miami Dade County and other areas where allowed by the Authority Having Jurisdiction (AHJ).

This NOA shall not be valid after the expiration date stated below. The Miami-Dade County Product Control Section (In Miami Dade County) and/or the AHJ (in areas other than Miami Dade County) reserve the right to have this product or material tested for quality assurance purposes. If this product or material fails to perform in the accepted manner, the manufacturer will incur the expense of such testing and the AHJ may immediately revoke, modify, or suspend the use of such product or material within their jurisdiction. PERA reserves the right to revoke this acceptance, if it is determined by Miami-Dade County Product Control Section that this product or material fails to meet the requirements of the applicable building code.

This product is approved as described herein, and has been designed to comply with the Florida Building Code including the High Velocity Hurricane Zone of the Florida Building Code.

DESCRIPTION: Landmark, Landmark Pro, Landmark Premium, Landmark Special and Landmark Solaris

LABELING: Each unit shall bear a permanent label with the manufacturer's name or logo, city, state and following statement: "Miami-Dade County Product Control Approved", unless otherwise noted herein.

RENEWAL of this NOA shall be considered after a renewal application has been filed and there has been no change in the applicable building code negatively affecting the performance of this product.

TERMINATION of this NOA will occur after the expiration date or if there has been a revision or change in the materials, use, and/or manufacture of the product or process. Misuse of this NOA as an endorsement of any product, for sales, advertising or any other purposes shall automatically terminate this NOA. Failure to comply with any section of this NOA shall be cause for termination and removal of NOA.

ADVERTISEMENT: The NOA number preceded by the words Miami-Dade County, Florida, and followed by the expiration date may be displayed in advertising literature. If any portion of the NOA is displayed, then it shall be done in its entirety.

INSPECTION: A copy of this entire NOA shall be provided to the user by the manufacturer or its distributors and shall be available for inspection at the job site at the request of the Building Official.

This revises NOA# 12-0201.05 and consists of pages 1 through 6.
The submitted documentation was reviewed by Alex Tigera.



NOA No.: 12-0403.02
Expiration Date: 02/28/17
Approval Date: 07/12/12
Page 1 of 6

ROOFING ASSEMBLY APPROVAL

Category: Roofing
Sub-Category: Asphalt Shingles
Materials: Dimensional
Deck Type: Wood

SCOPE

This renews **CertainTeed Landmark, Landmark Pro, Landmark Premium, Landmark Special and Landmark Solaris** Shingles as manufactured by **CertainTeed Corporation** described in Section 2 of this Notice of Acceptance.

PRODUCT DESCRIPTION

<u>Product</u>	<u>Dimensions</u>	<u>Test Specifications</u>	<u>Product Description</u>
CertainTeed Landmark <i>Manufacturing Locations #1, 2, 3, 4</i>	13¼" x 38 ¾"	TAS 110	A heavy weight, 247lb/sq, dimensional asphalt shingle.
CertainTeed Landmark Pro <i>Manufacturing Locations #1, 3, 4</i>	13¼" x 38 ¾"	TAS 110	A heavy weight, 264lb/sq, dimensional asphalt shingle.
CertainTeed Landmark Premium <i>Manufacturing Locations #1, 3, 4</i>	13¼" x 38 ¾"	TAS 110	A heavy weight, 296lb/sq, dimensional asphalt shingle.
CertainTeed Landmark Special <i>Manufacturing Locations #1</i>	13¼" x 38 ¾"	TAS 110	A heavy weight, 264lb/sq, dimensional asphalt shingle.
CertainTeed Landmark Solaris <i>Manufacturing Locations #1</i>	13¼" x 38 ¾"	TAS 110	A heavy weight, 296lb/sq, dimensional asphalt shingle.
Accessory Shingles	various	proprietary	Accessory shingles for hip, ridge and starter strip applications.

MANUFACTURING LOCATION(S):

1. Peachtree City, GA.
2. Ennis, TX.
3. Oxford, NC.
4. Shakopee, MN.



NOA No.: 12-0403.02
Expiration Date: 02/28/17
Approval Date: 07/12/12
Page 2 of 6

EVIDENCE SUBMITTED:

<u>Test Agency</u>	<u>Test Identifier</u>	<u>Test Name/Report</u>	<u>Date</u>
Underwriters Laboratories, Inc.	R684	UL 790	04/02/01
PRI Asphalt Technologies, Inc.	PCTC-01-02-01	TAS 100	01/12/01
	CTC-006-02-01	TAS 100	11/12/02
PRI Construction Materials Technologies	CTC-092-02-01	TAS 100	02/23/12
	CTC-091-02-01	TAS 100	02/21/12
	CTC-090-02-01	TAS 100	09/02/11
	CTC-087-02-01	TAS 100	07/07/11
	CTC-086-02-01	TAS 100	07/07/11
	CTC-101-02-01	TAS 100	10/05/11
	CTC-102-02-01	TAS 100	10/05/11
Underwriters Laboratories, Inc.	94NK9632	Wind uplift resistance TAS 107	11/30/00
	02NK42448	Wind uplift resistance TAS 107	11/08/02
	09CA28873	Letter	07/23/09
	11CA59020	TAS 107/ ASTM D3161	01/25/12
	11NK07864	TAS 107/ ASTM D3161	09/29/11
	07CA26696	TAS 107/ ASTM D3161	09/21/07
	11CA38844	TAS 107/ ASTM D3161	01/28/12
Underwriters Laboratories, Inc.	11NK08333	ASTM D3462	05/15/12
	11NK08333	ASTM D3462	04/15/12
	11NK07864	ASTM D3462	09/29/11

LIMITATIONS

1. Fire classification is not part of this acceptance; refer to a current Approved Roofing Materials Directory for fire ratings of this product.
2. Shall not be installed on roof mean heights in excess of 33 ft.

INSTALLATION

1. Shingles shall be installed in compliance with Roofing Application Standard RAS 115.
2. Flashing shall be in accordance with Roofing Application Standard RAS 115
3. The manufacturer shall provide clearly written application instructions.
4. Exposure and course layout shall be in compliance with Detail 'A', attached.
5. Nailing shall be in compliance with Detail 'B', attached.



LABELING

1. Shingles shall be labeled with the Miami-Dade Product Control approved seal as seen below or the wording "Miami-Dade County Product Control Approved".



BUILDING PERMIT REQUIREMENTS

1. Application for building permit shall be accompanied by copies of the following:
 - 1.1 This Notice of Acceptance.
 - 1.2 Any other documents required by the Building Official or the applicable code in order to properly evaluate the installation of this system.



DETAIL A

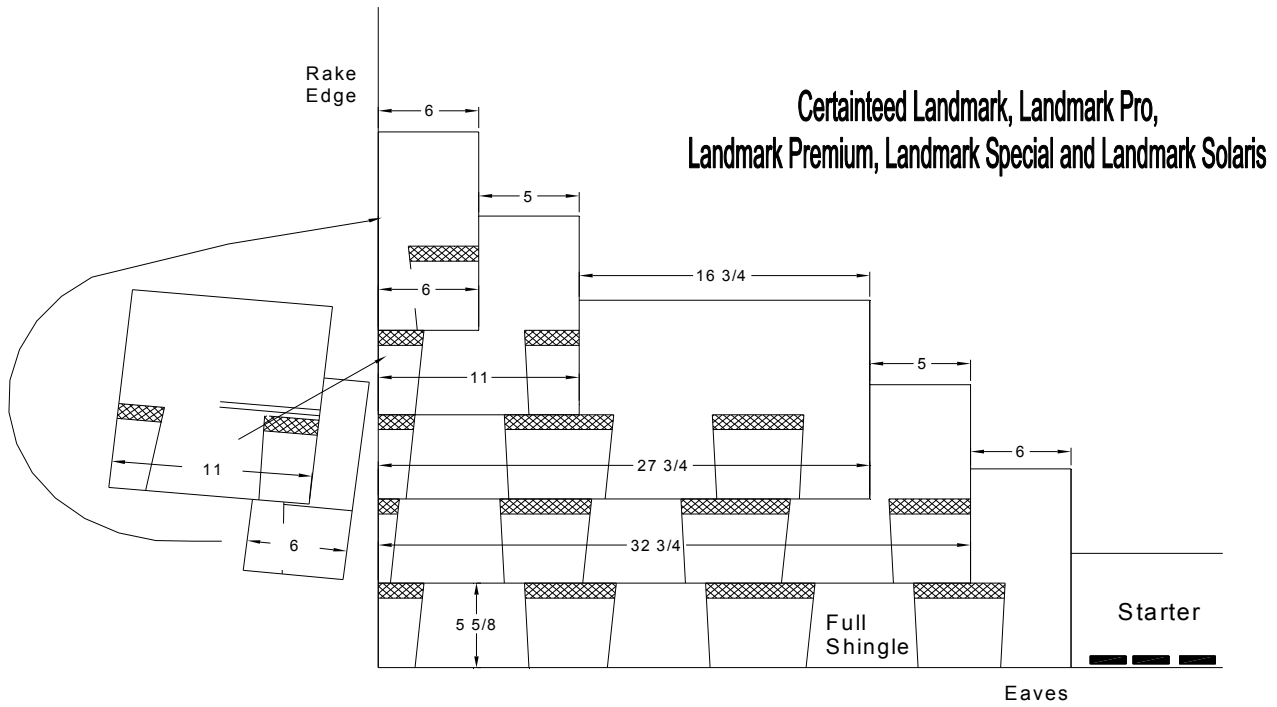

DETAIL B

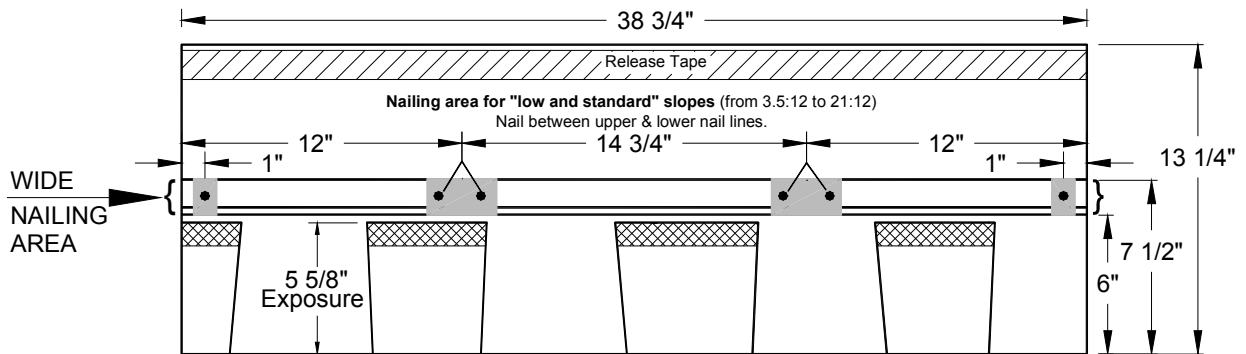

Landmark, Landmark Pro, Landmark Premium, Landmark Special and Landmark Solaris
(Low and Standard Slope)

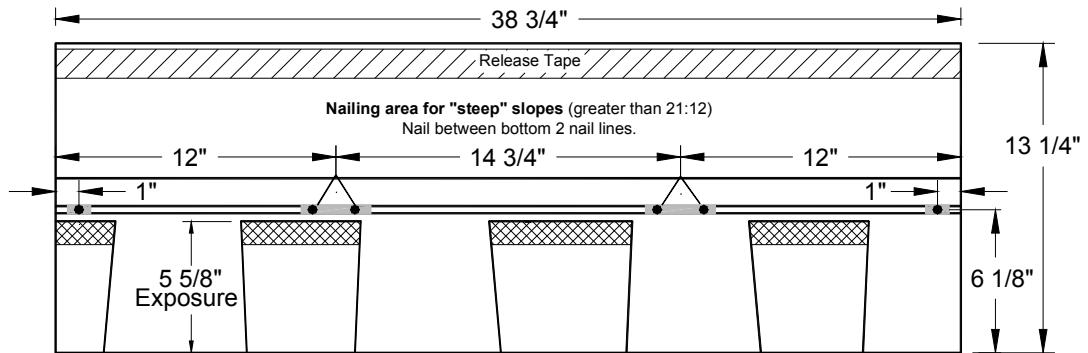

Landmark, Landmark Pro, Landmark Premium, Landmark Special and Landmark Solaris
(Steep Slope)

END OF THIS ACCEPTANCE

