



DEPARTMENT OF REGULATORY AND ECONOMIC RESOURCES (RER)
BOARD AND CODE ADMINISTRATION DIVISION

MIAMI-DADE COUNTY
PRODUCT CONTROL SECTION
11805 SW 26 Street, Room 208
Miami, Florida 33175-2474
T (786) 315-2590 F (786) 315-2599

NOTICE OF ACCEPTANCE (NOA)

www.miamidade.gov/economy

Westech Building Products, Inc.
P. O. Box 567
Mount Vernon, IN 47620

SCOPE:

This NOA is being issued under the applicable rules and regulations governing the use of construction materials. The documentation submitted has been reviewed and accepted by Miami-Dade County RER- Product Control Section to be used in Miami Dade County and other areas where allowed by the Authority Having Jurisdiction (AHJ).

This NOA shall not be valid after the expiration date stated below. The Miami-Dade County Product Control Section (In Miami Dade County) and/or the AHJ (in areas other than Miami Dade County) reserve the right to have this product or material tested for quality assurance purposes. If this product or material fails to perform in the accepted manner, the manufacturer will incur the expense of such testing and the AHJ may immediately revoke, modify, or suspend the use of such product or material within their jurisdiction. RER reserves the right to revoke this acceptance, if it is determined by Miami-Dade County Product Control Section that this product or material fails to meet the requirements of the applicable building code.

This product is approved as described herein, and has been designed to comply with the High Velocity Hurricane Zone of the Florida Building Code.

DESCRIPTION: Extruded PVC Vinyl Fencing Systems

APPROVAL DOCUMENT: Drawing No. 10-02, titled " PVC Privacy Fence systems ", sheets 1 through 9 of 9, prepared by Al-Farooq Corporation, dated April 09, 2010, last revision #B dated June 06, 2012, signed and sealed by Javad Ahmad, P.E., bearing the Miami-Dade County Product Control Revision stamp with the Notice of Acceptance number and the expiration date by the Miami-Dade County Product Control Section.

MISSILE IMPACT RATING: None

LABELING: Each fence section shall bear a permanent label with the manufacturer's name or logo, city, state, and the following statement: "Miami-Dade County Product Control Approved", unless otherwise noted herein.

RENEWAL of this NOA shall be considered after a renewal application has been filed and there has been no change in the applicable building code negatively affecting the performance of this product.

TERMINATION of this NOA will occur after the expiration date or if there has been a revision or change in the materials, use, and/or manufacture of the product or process. Misuse of this NOA as an endorsement of any product, for sales, advertising or any other purposes shall automatically terminate this NOA. Failure to comply with any section of this NOA shall be cause for termination and removal of NOA.

ADVERTISEMENT: The NOA number preceded by the words Miami-Dade County, Florida, and followed by the expiration date may be displayed in advertising literature. If any portion of the NOA is displayed, then it shall be done in its entirety.

INSPECTION: A copy of this entire NOA shall be provided to the user by the manufacturer or its distributors and shall be available for inspection at the job site at the request of the Building Official.

This NOA revises NOA # 10-0512.03 and consists of this page 1, evidence submitted pages E-1 & E-2 as well as approval document mentioned above.

The submitted documentation was reviewed by **Helmy A. Makar, P.E., M.S.**



Helmy A. Makar
09/27/2012

NOA No. 12-0612.22
Expiration Date: 10/06/2015
Approval Date: 09/27/2012
Page 1

Westech Building Products, Inc.

NOTICE OF ACCEPTANCE: EVIDENCE SUBMITTED

1. EVIDENCE SUBMITTED UNDER PREVIOUS APPROVAL # 10-0512.03

A. DRAWINGS

1. *Drawing No. 10-02, titled " PVC Privacy Fence systems ", sheets 1 through 9 of 9, prepared by Al-Farooq Corporation, dated April 09, 2010, last revision #A dated September 02, 2010, signed and sealed by Javad Ahmad, P.E.*

B. TESTS

1. *Test report on Uniform Static Air Pressure Test, prepared by Architectural Testing, Report # 91017.02-119-18, dated September 17, 2009, signed and sealed by Joseph A. Reed, P.E.*

C. CALCULATIONS

1. *Calculations titled PVC Privacy fence System (4 ft & 6 ft tall), by Al-Farooq Corporation, dated April 30, 2010, sheets L1, D-1, CR-1, WL-1 to WL-7, TR-1 to TR-4, & C-1 to C-34, signed and sealed by Javad Ahmad, P.E., on May 04, 2010.*

D. MATERIAL CERTIFICATIONS

1. *Extruded Profile (Phantom) Specification sheets.*

E. STATEMENTS

1. *Letter regarding the compliance with Florida Building Code 2007 and the lack of financial interest, prepared by Al-Farooq Corporation, dated April 30, 2010, signed and sealed by Javad Ahmad, P.E., on May 04, 2010.*

2. NEW EVIDENCE SUBMITTED

A. DRAWINGS

1. *Drawing No. 10-02, titled " PVC Privacy Fence systems ", sheets 1 through 9 of 9, prepared by Al-Farooq Corporation, dated April 09, 2010, last revision #B dated June 06, 2012, signed and sealed by Javad Ahmad, P.E.*

B. TESTS

1. *None.*

C. CALCULATIONS

1. *None.*

D. QUALITY ASSURANCE

1. *By Miami-Dade County Department of Regulatory and Economic Resources.*

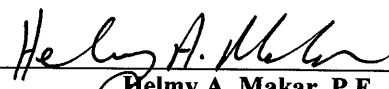

Helmy A. Makar, P.E., M.S.
Product Control Unit Supervisor

NOA No. 12-0612.22

Expiration Date: 10/06/2015

Approval Date: 09/27/2012

Westech Building Products, Inc.

NOTICE OF ACCEPTANCE: EVIDENCE SUBMITTED

E. MATERIAL CERTIFICATIONS

1. *None.*

F. STATEMENTS

1. *Letter regarding the compliance with Florida Building Code 2010 and the lack of financial interest, prepared by Al-Farooq Corporation, dated June 06, 2012, signed and sealed by Javad Ahmad, P.E.*

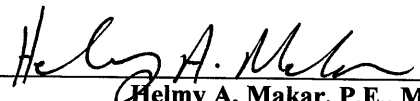

Helmy A. Makar, P.E., M.S.
Product Control Unit Supervisor
NOA No. 12-0612.22
Expiration Date: 10/06/2015
Approval Date: 09/27/2012

PVC PRIVACY FENCE SYSTEMS

THIS PRODUCT HAS BEEN DESIGNED AND TESTED TO COMPLY WITH THE REQUIREMENTS OF THE FLORIDA BUILDING CODE 2010 EDITION INCLUDING HIGH VELOCITY HURRICANE ZONE (HVHZ).

INSTALLATION OR LOADING CONDITIONS OTHER THAN THOSE SHOWN IN THESE DETAILS ARE NOT PART OF THIS APPROVAL.

ALL CONCRETE SHALL HAVE A 28 DAY COMPRESSIVE STRENGTH OF 3000 PSI.

FENCE SYSTEMS COVERED UNDER THIS APPROVAL SHALL BE MANUFACTURED FROM RIGID PVC HOMOPOLYMER, SIC 3084 PROFILES.

FENCES SHALL BE INSTALLED AS PER MANUF'S INSTALLATION INSTRUCTIONS.

PRODUCT MARKING

A LABEL SHALL BE AFFIXED ON EACH FENCE WITH THE FOLLOWING STATEMENT.

WESTECH BUILDING PRODUCTS, INC., VERNON, IN.
'MIAMI-DADE COUNTY PRODUCT CONTROL APPROVED'

FENCE SYSTEMS ARE DESIGNED FOR 75 MPH WIND SPEED OR 115 MPH 3 SECOND GUSTS IN COMPLIANCE WITH SECTION 1615.2.1 OF THE FLORIDA BUILDING CODE.

Engr: JAVAD AHMAD
CIVIL
FLA. PE # 70592
C.A.N. 3538

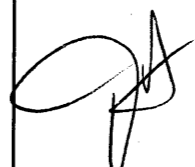

JUN 07 2012

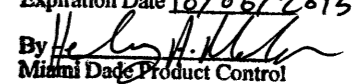
PRODUCT REVISED
as complying with the Florida
Building Code
Acceptance No 12-0612-22
Expiration Date 10/06/2015
By 
Miami Dade Product Control

AL-FAROOQ CORPORATION
ENGINEERS & PRODUCT DEVELOPMENT
1235 S.W. 87 AVE
MIAMI, FLORIDA 33174
TEL. (305) 264-8100 FAX. (305) 262-6978
FENCES\10-02WBP

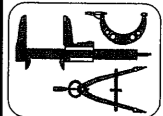

PVC PRIVACY FENCE SYSTEMS
WESTECH BUILDING PRODUCTS, INC.
7451 HIGHWAY 62 EAST
MOUNT VERNON, INDIANA. 47620
TEL. (812) 985-3628 FAX. (812) 985-2925

| no | date | by | description |
|----|----------|----|------------------------|
| A | 09.02.10 | | REV. PER BCCO COMMENTS |
| B | 06.06.12 | | UPDATED TO 2010 FBC |
| | | | |
| | | | |

date: 04-09-10
scale: -
dr. by: HAMID
chk. by:

drawing no.
10-02
sheet 1 of 9

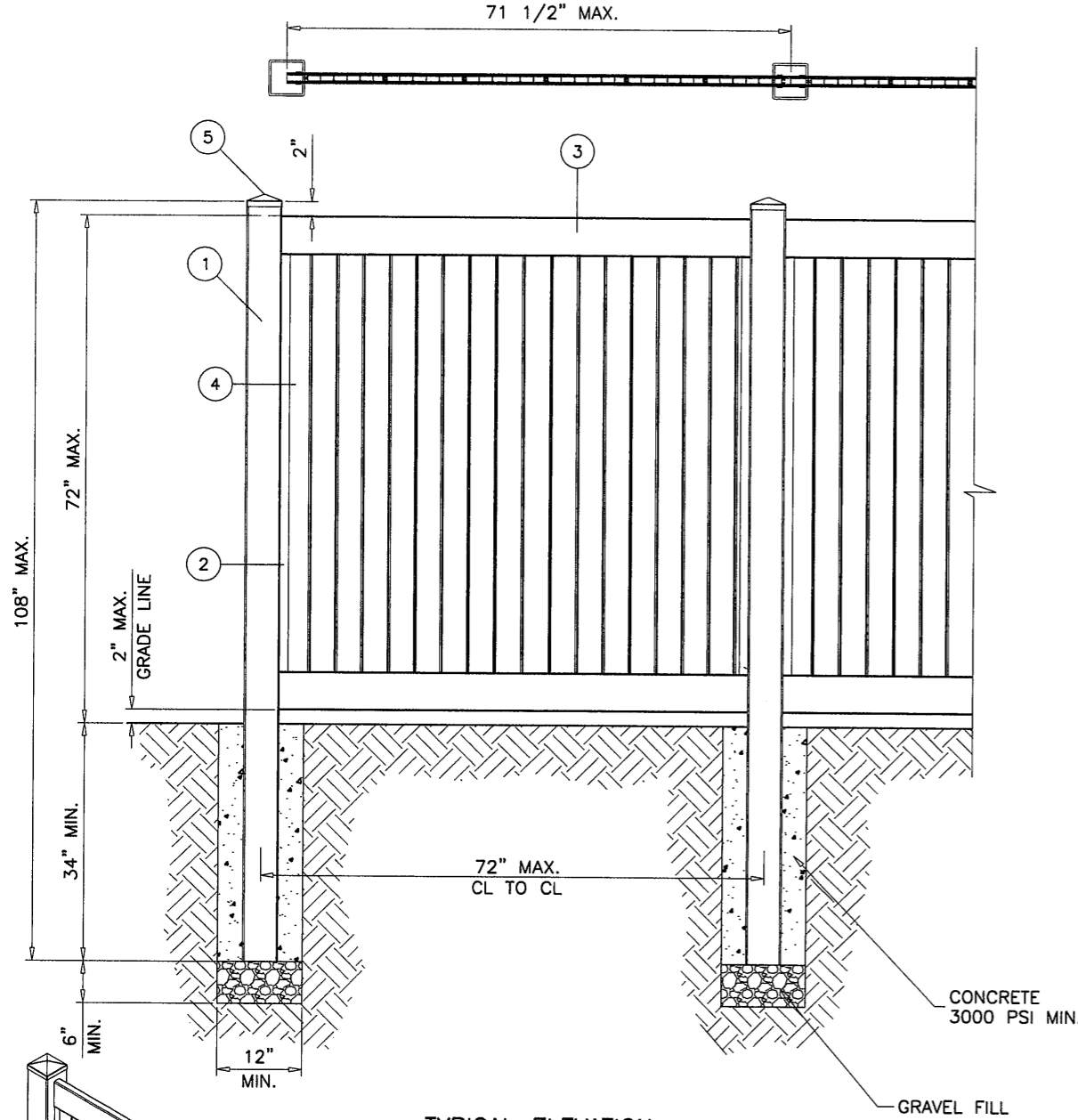

TYPICAL ELEVATION
1/2" = 1'-0"

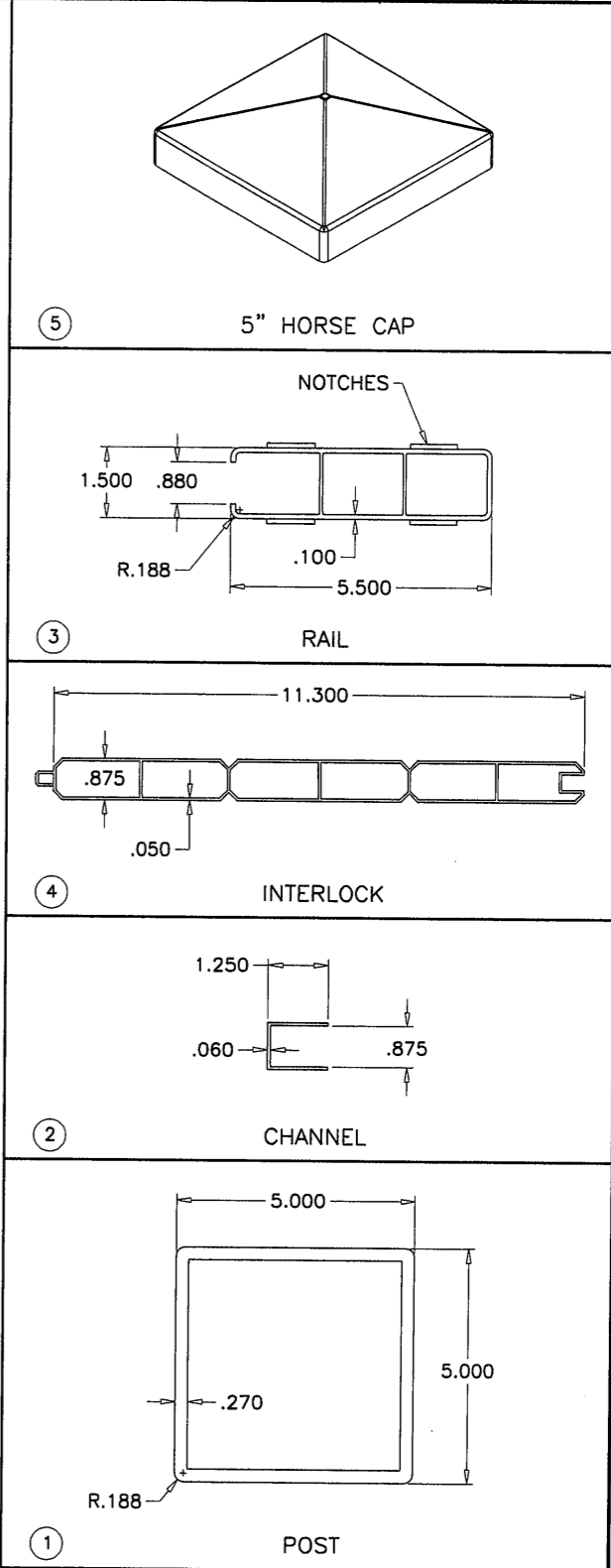
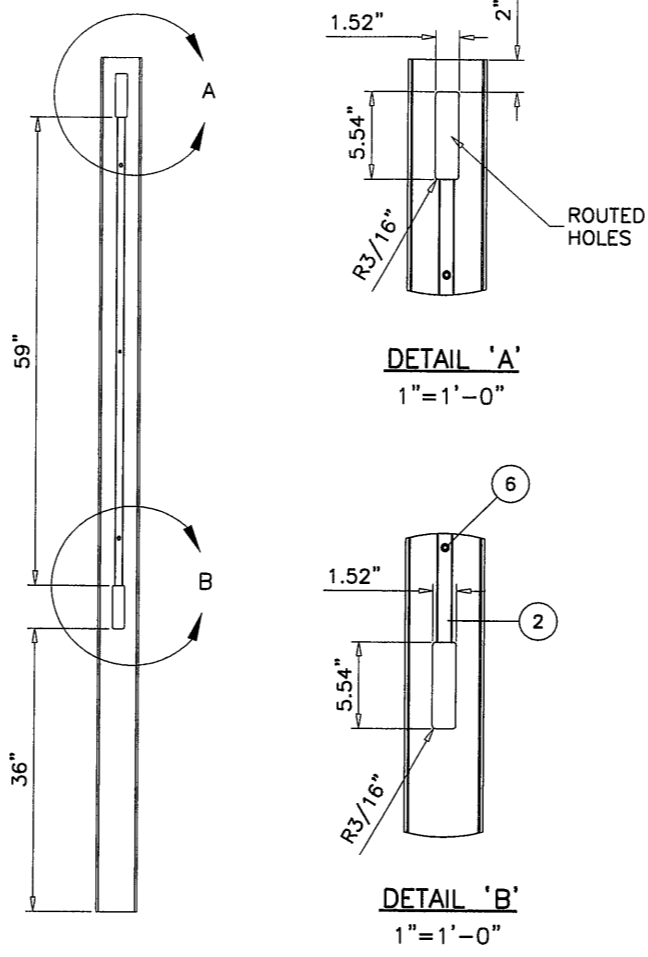

11.3" T&G PRIVACY FENCE

| ITEM NO. | PART DESCRIPTION | LENGTH IN. |
|----------|----------------------|------------|
| 1 | 5" X 5" POST | 108 |
| 2 | 7/8" U CHANNEL | 58-7/8 |
| 3 | 1-1/2" X 5-1/2" RAIL | 71-1/2 |
| 4 | 7/8" X 11.3" T&G | 62-1/4 |
| 5 | 5" HORSE CAP | N/A |
| 6 | 1/2" FASTENERS | N/A |

Engr: JAVAD AHMAD
CIVIL
FLA. PE # 70592
C.A.N. 3538

[Signature]
JUN 07 2012

PRODUCT REVISED
as complying with the Florida
Building Code
Acceptance No 12-0612.22
Expiration Date 10/06/2015

By *[Signature]*
Miami Dade Product Control

AL-FAROOQ CORPORATION
ENGINEERS & PRODUCT DEVELOPMENT
1235 S.W. 87 AVE
MIAMI, FLORIDA 33174
TEL. (305) 264-8100 FAX. (305) 262-6978

AFC

PVC PRIVACY FENCE SYSTEMS

WESTECH BUILDING PRODUCTS, INC.
7451 HIGHWAY 62 EAST
MOUNT VERNON, INDIANA, 47620
TEL. (812) 985-3628 FAX. (812) 985-2925

revisions:

| no | date | by | description |
|----|----------|------------------------|-------------|
| A | 09.02.10 | REV. PER BCCO COMMENTS | |
| B | 06.06.12 | NO CHANGE THIS SHEET | |

date: 04-09-10
scale: 1/4" = 1"
dr. by: HAMID
chk. by:

drawing no.
10-02

sheet 2 of 9

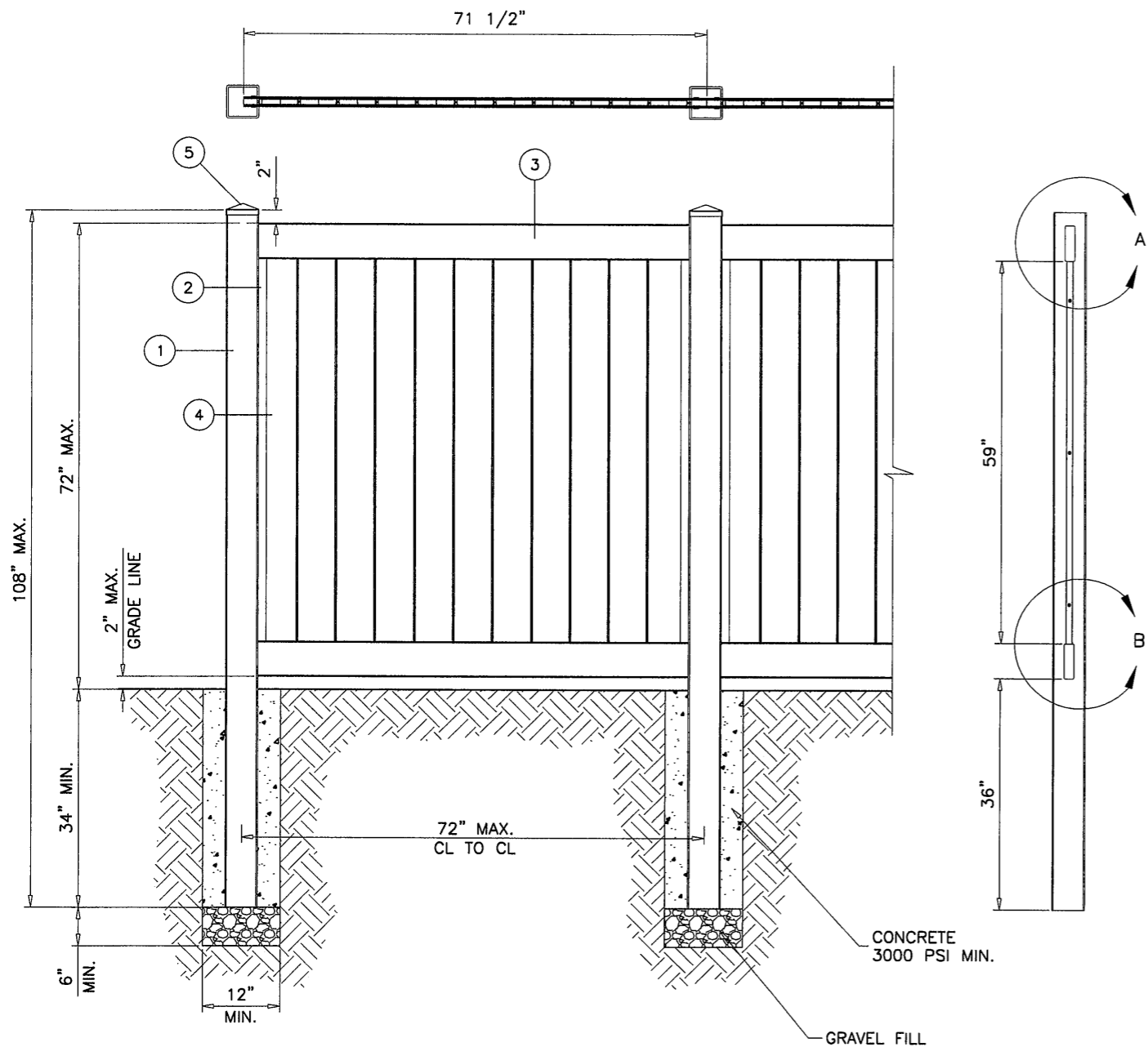

TYPICAL ELEVATION
1/2" = 1'-0"

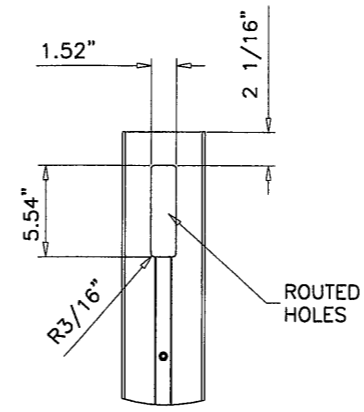

DETAIL 'A'
1" = 1'-0"

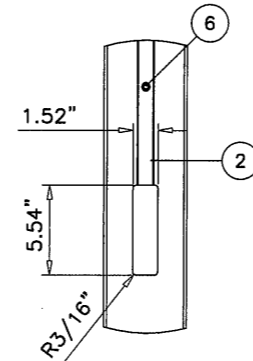

DETAIL 'B'
1" = 1'-0"

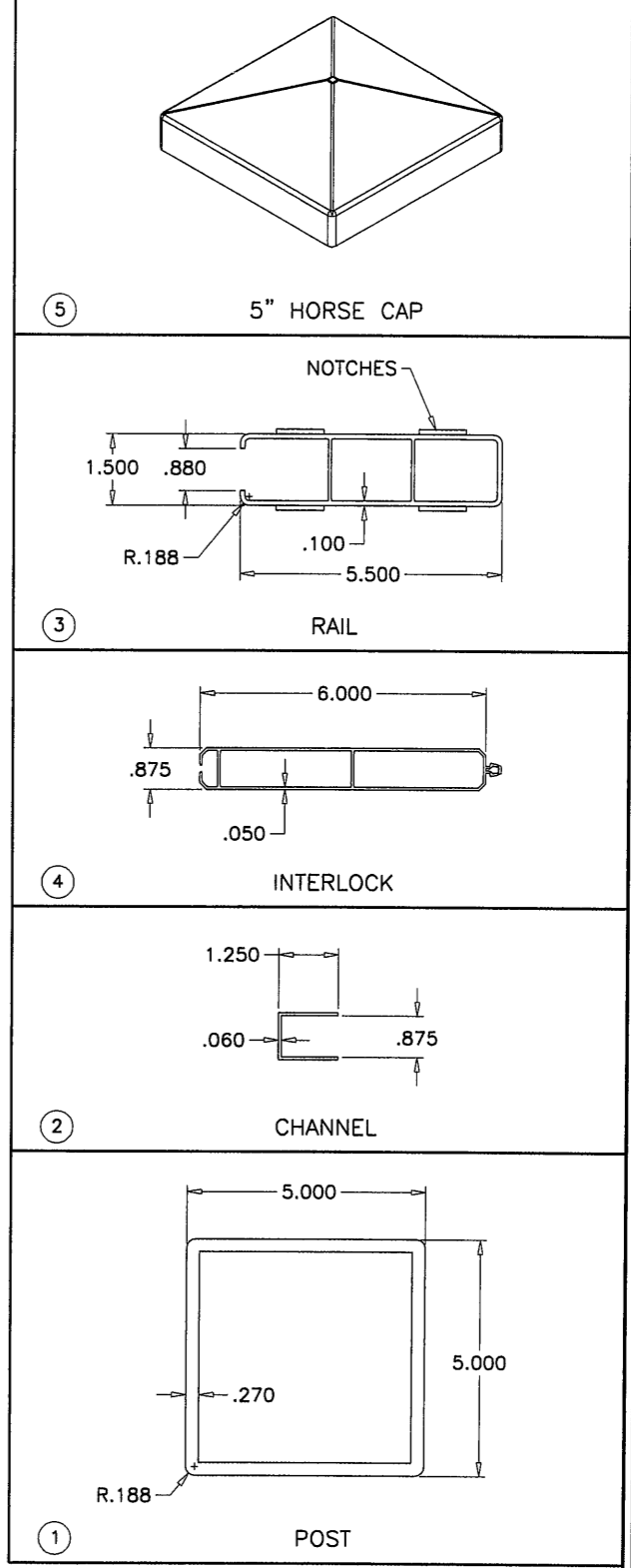

6" T&G PRIVACY FENCE

| ITEM NO. | PART DESCRIPTION | LENGTH IN. |
|----------|----------------------|------------|
| 1 | 5" X 5" POST | 108 |
| 2 | 7/8" U CHANNEL | 58-7/8 |
| 3 | 1-1/2" X 5-1/2" RAIL | 71-1/2 |
| 4 | 7/8" X 6" T&G | 62-1/4 |
| 5 | 5" HORSE CAP | N/A |
| 6 | 1/2" FASTENERS | N/A |

Engr: JAVAD AHMAD
CIVIL
FLA. PE # 70592
C.A.N. 3538

[Signature]
JUN 07 2012

PRODUCT REVISED
as complying with the Florida
Building Code
Acceptance No. 12-0612-27
Expiration Date 10/06/2015

By *[Signature]*
Miami Dade Product Control

AL-FAROOQ CORPORATION
ENGINEERS & PRODUCT DEVELOPMENT
1235 S.W. 87 AVE
MIAMI, FLORIDA 33174
TEL. (305) 264-8100 FAX. (305) 262-6978

WESTECH BUILDING PRODUCTS, INC.
7451 HIGHWAY 62 EAST
MOUNT VERNON, INDIANA. 47620
TEL. (812) 985-3628 FAX. (812) 985-2925

PVC PRIVACY FENCE SYSTEMS

| no | date | by | description |
|----|----------|-----------|---------------|
| A | 09.02.10 | REV. PER | BCCO COMMENTS |
| B | 06.06.12 | NO CHANGE | THIS SHEET |

revisions:

date: 04-09-10
scale: 1/4" = 1"
dr. by: HAMID
chk. by:

drawing no.
10-02

sheet 3 of 9

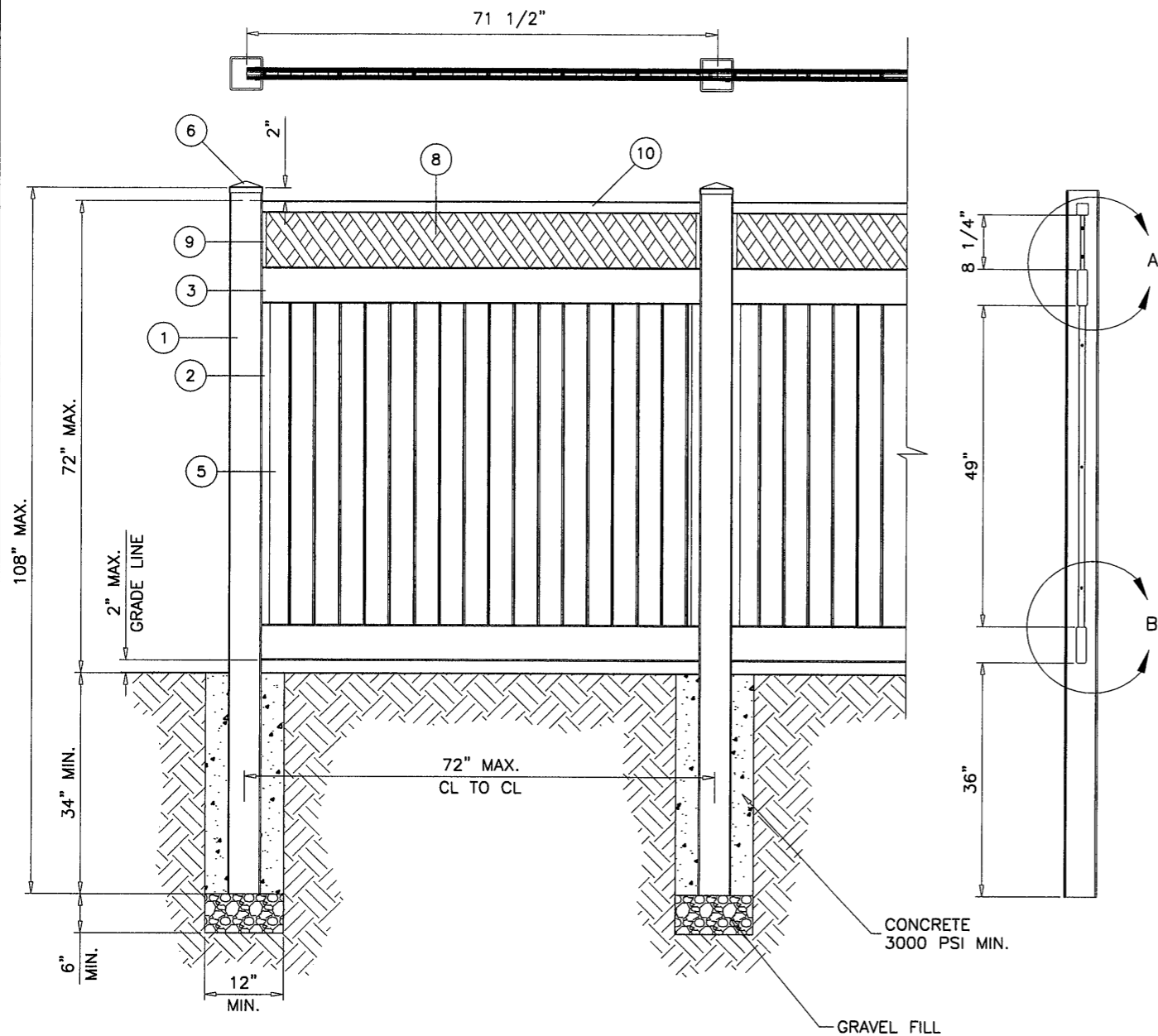

TYPICAL ELEVATION
1/2" = 1'-0"

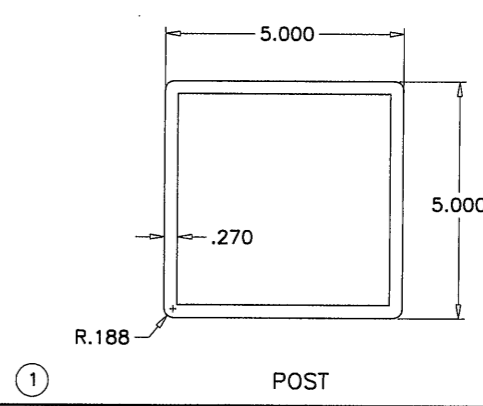
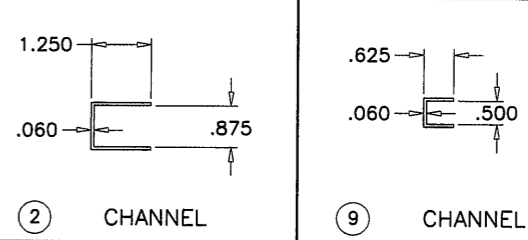
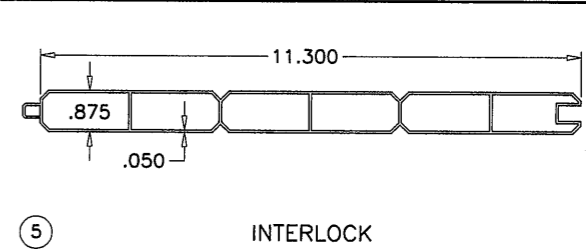
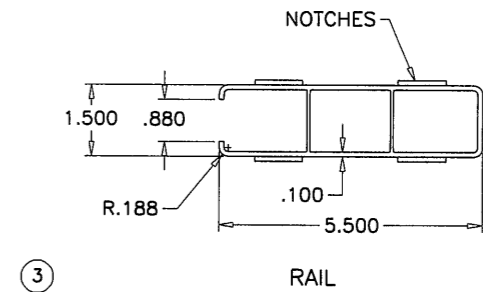
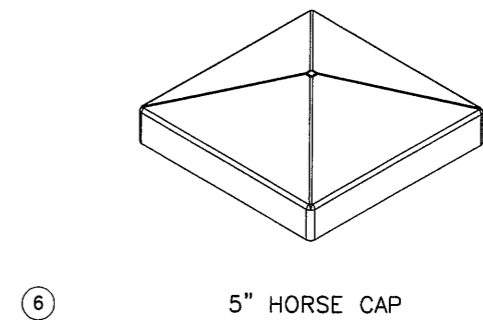
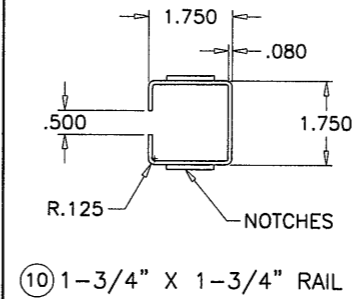
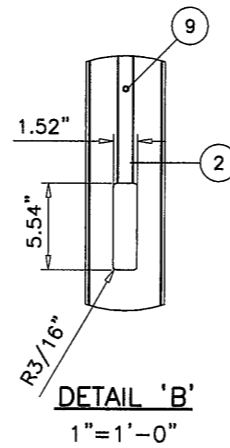
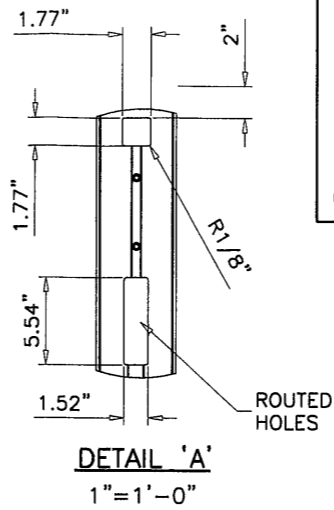
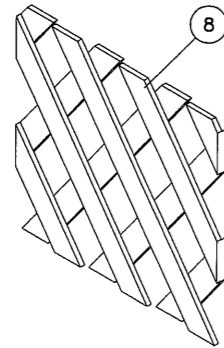
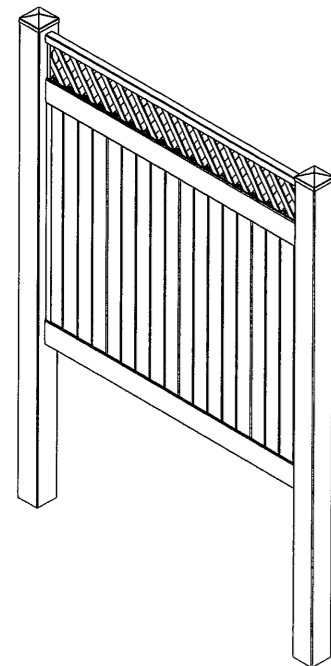

LATTICE ACCENT 11.3" PRIVACY FENCE

| ITEM NO. | PART DESCRIPTION | LENGTH IN. |
|----------|----------------------|------------|
| 1 | 5" X 5" POST | 108 |
| 2 | 7/8" U CHANNEL | 48-7/8 |
| 3 | 1-1/2" X 5-1/2" RAIL | 71-1/2 |
| 5 | 7/8" X 11.3" T&G | 52-1/4 |
| 6 | 5" HORSE CAP | N/A |
| 8 | 1/2" LATTICE | N/A |
| 9 | 5/8" U CHANNEL | 8-1/4 |
| 10 | 1-3/4" X 1-3/4" RAIL | 71-1/2 |
| 11 | 1/2" FASTENERS | N/A |

Engr: JAVAD AHMAD
CIVIL
FLA. PE # 70592
C.A.N. 3538

[Signature]
JUN 07 2012

PRODUCT REVISED
as complying with the Florida
Building Code
Acceptance No 12-0612.22
Expiration Date 10/06/2015

By *[Signature]*
Miami Dade Product Control

AL-FAROOQ CORPORATION
ENGINEERS & PRODUCT DEVELOPMENT
1235 S.W. 87 AVE
MIAMI, FLORIDA 33174
TEL. (305) 264-8100 FAX. (305) 262-6978

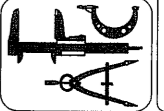

PVC PRIVACY FENCE SYSTEMS
WESTECH BUILDING PRODUCTS, INC.
7451 HIGHWAY 62 EAST
MOUNT VERNON, INDIANA. 47620
TEL. (812) 985-3628 FAX. (812) 985-2925

revisions:

| no | date | by | description |
|----|----------|----|------------------------|
| A | 09.02.10 | | REV. PER BCCO COMMENTS |
| B | 06.06.12 | | NO CHANGE THIS SHEET |

date: 04-09-10
scale: 1/4" = 1"
dr. by: HAMID
chk. by:

drawing no.
10-02
sheet 4 of 9

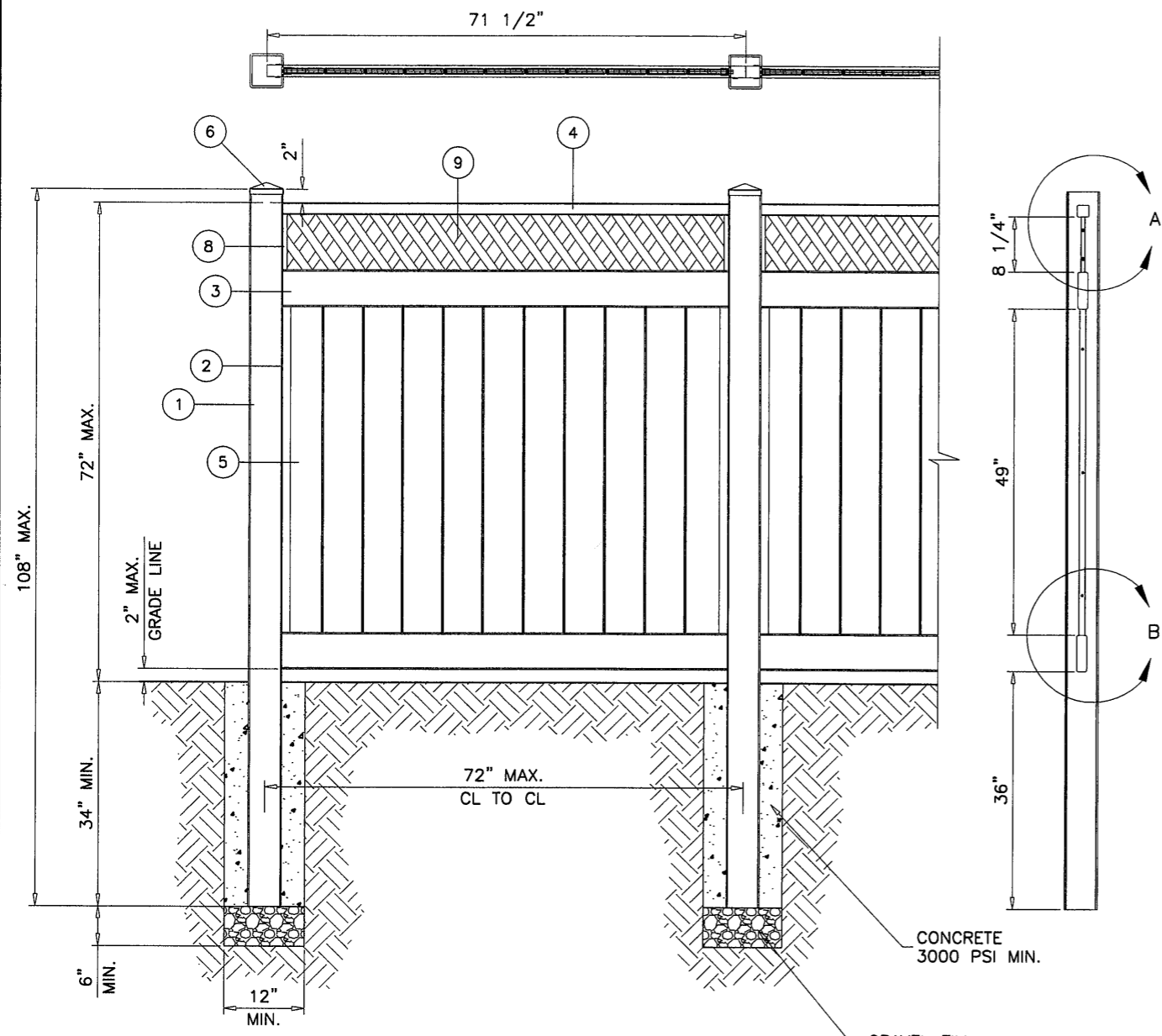

TYPICAL ELEVATION
1/2" = 1'-0"

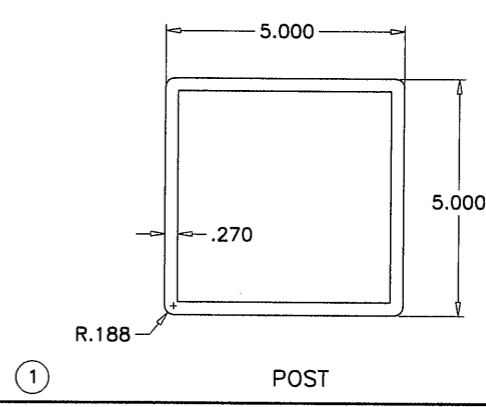
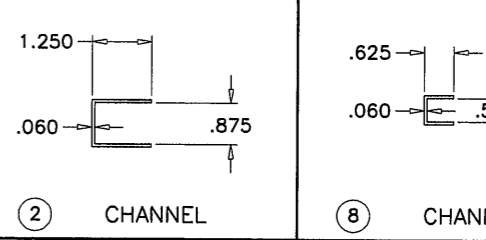
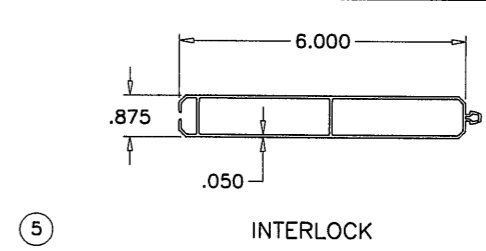
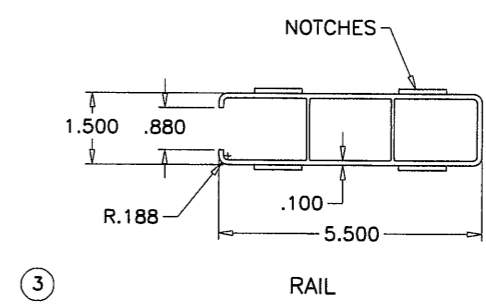
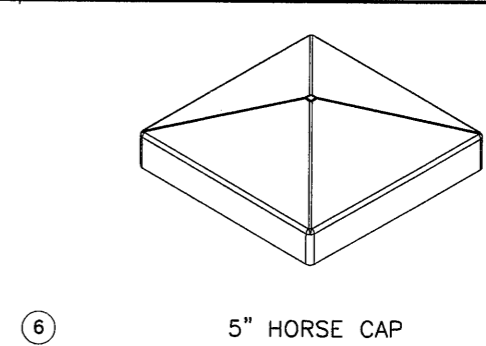
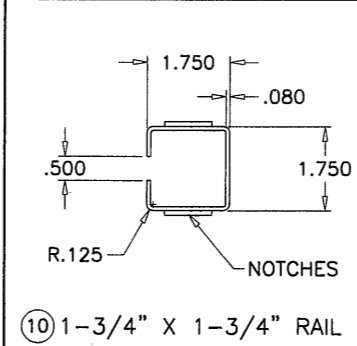
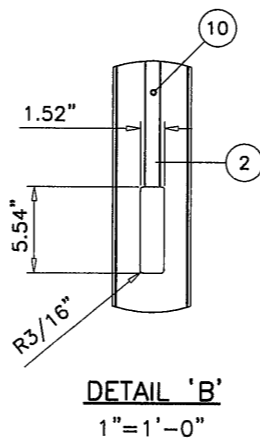
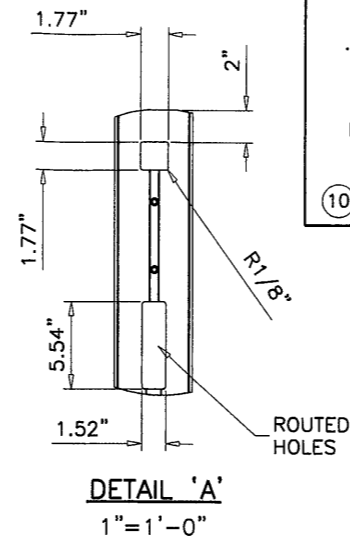
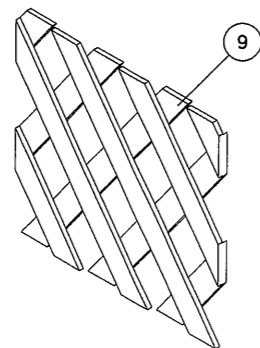
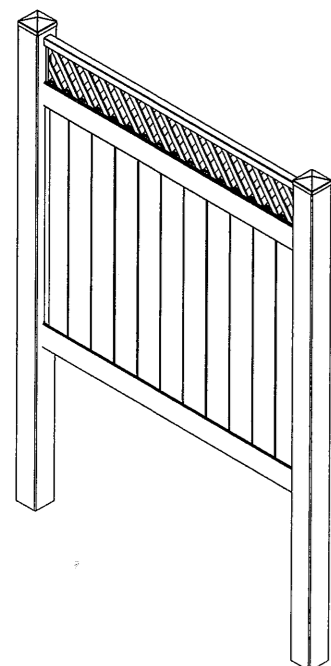

LATTICE ACCENT 6" PRIVACY FENCE

| ITEM NO. | PART DESCRIPTION | LENGTH IN. |
|----------|----------------------|------------|
| 1 | 5" X 5" POST | 108 |
| 2 | 7/8" U CHANNEL | 48-7/8 |
| 3 | 1-1/2" X 5-1/2" RAIL | 71-1/2 |
| 4 | 1-3/4" X 1-3/4" RAIL | 71-1/2 |
| 5 | 7/8" X 6" T&G | 52-1/4 |
| 6 | 5" HORSE CAP | N/A |
| 8 | 5/8" U CHANNEL | 8-1/4 |
| 9 | 1/2" LATTICE | N/A |
| 10 | 1/2" FASTENERS | N/A |

Engr: JAVAD AHMAD
CIVIL
FLA. PE # 70592
C.A.N. 3538

[Signature]
JUN 07 2012

PRODUCT REVISED
as complying with the Florida
Building Code
Acceptance No 12-0612.22
Expiration Date 10/06/2015

By *[Signature]*
Miami Dade Product Control

AL-FAROOQ CORPORATION
ENGINEERS & PRODUCT DEVELOPMENT
1235 S.W. 87 AVE
MIAMI, FLORIDA 33174
TEL. (305) 264-8100 FAX. (305) 262-6978

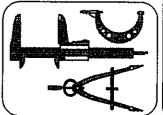

PVC PRIVACY FENCE SYSTEMS
WESTECH BUILDING PRODUCTS, INC.
7451 HIGHWAY 62 EAST
MOUNT VERNON, INDIANA. 47620
TEL. (812) 985-3628 FAX. (812) 985-2925

revisions:

| no | date | by | description |
|----|----------|------------------------|-------------|
| A | 09.02.10 | REV. PER BCCO COMMENTS | |
| B | 06.06.12 | NO CHANGE THIS SHEET | |

date: 04-09-10
scale: 1/4" = 1"
dr. by: HAMID
chk. by:

drawing no.
10-02
sheet 5 of 9

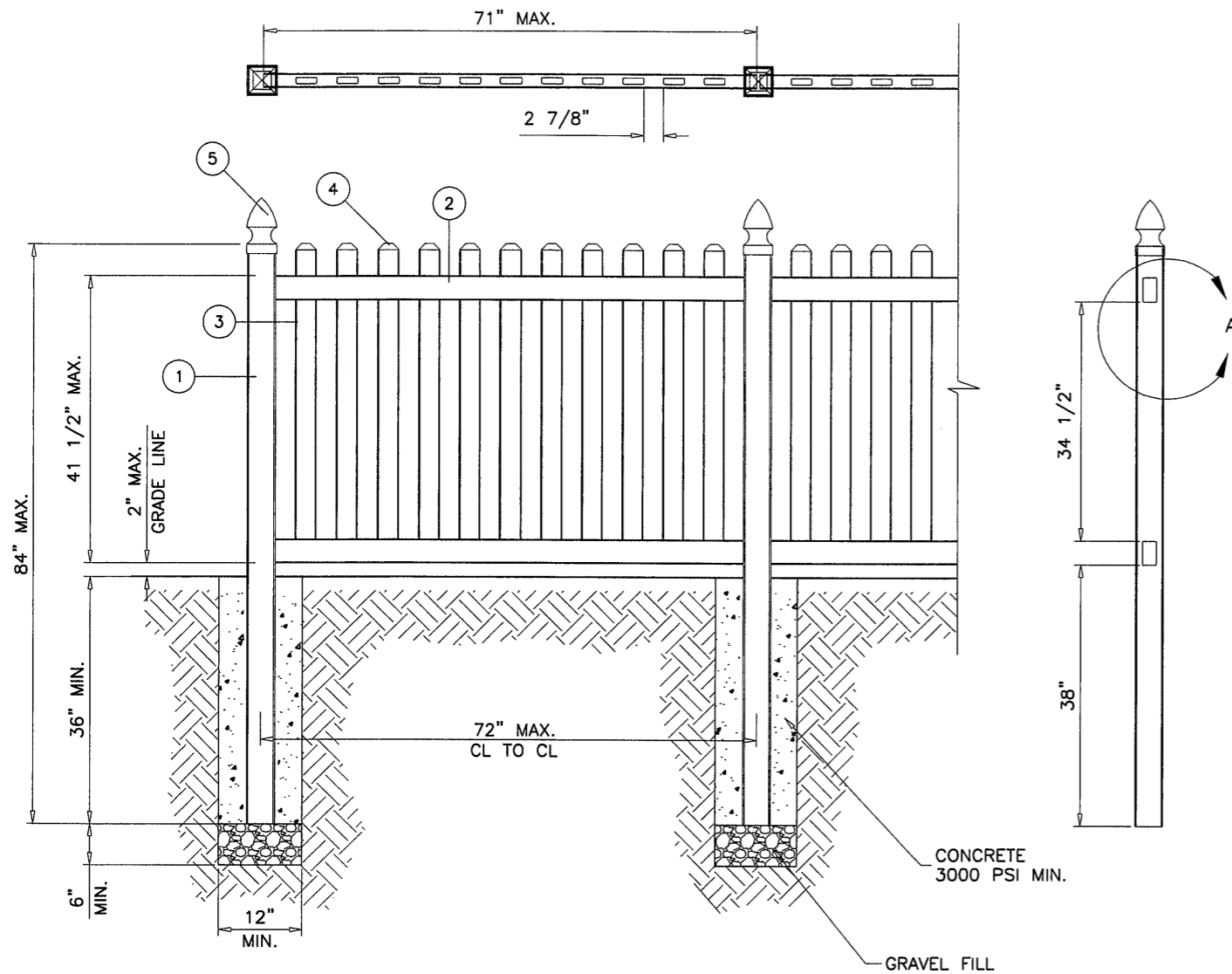

TYPICAL ELEVATION
1/2" = 1'-0"

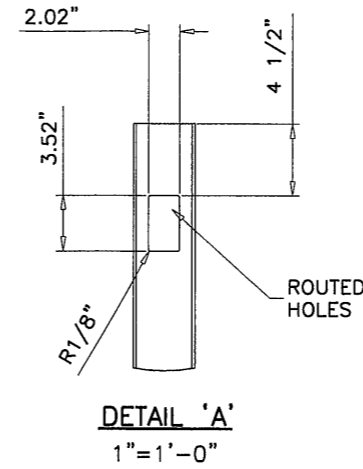

DETAIL 'A'
1" = 1'-0"

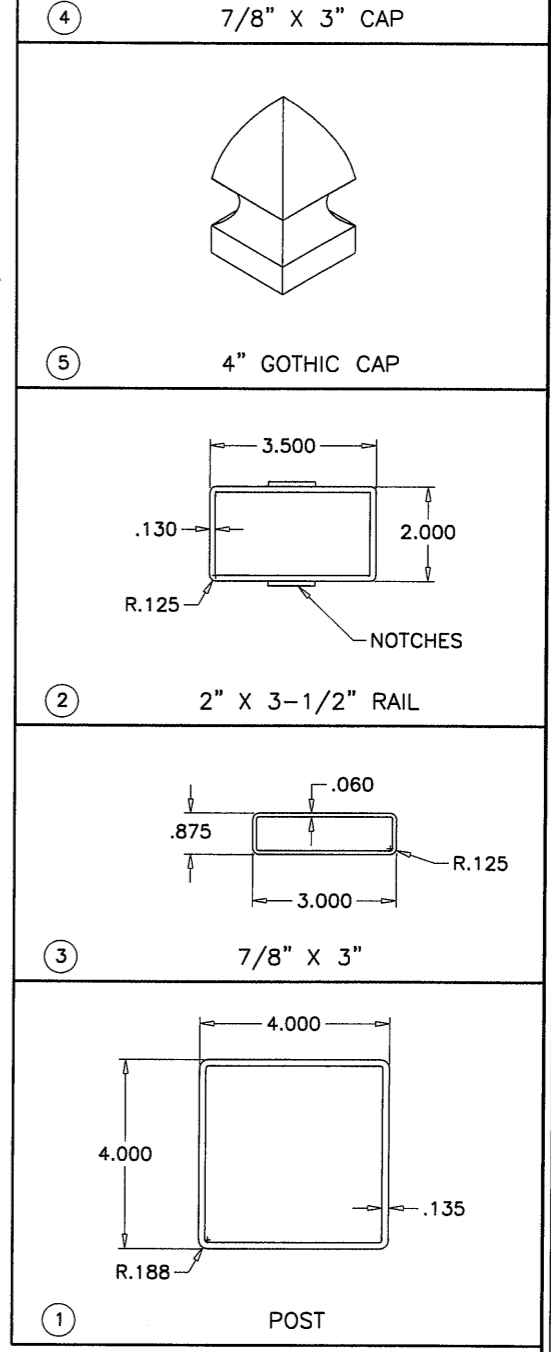

KEYWEST PICKET FENCE

| ITEM NO. | PART DESCRIPTION | LENGTH IN. |
|----------|------------------|------------|
| 1 | 4" X 4" POST | 84 |
| 2 | 2" X 3-1/2" RAIL | 71 |
| 3 | 7/8" X 3" PICKET | 45 |
| 4 | 7/8" X 3" CAP | N/A |
| 5 | 4" GOTHIC CAP | N/A |

Engr: JAVAD AHMAD
CIVIL
FLA. PE # 70592
C.A.N. 3538

J.A.
JUN 07 2012

PRODUCT REVISED
as complying with the Florida
Building Code
Acceptance No 12-0612.22
Expiration Date 10/06/2015

By *[Signature]*
Miami Dade Product Control

AL-FAROOQ CORPORATION
ENGINEERS & PRODUCT DEVELOPMENT
1235 S.W. 87 AVE
MIAMI, FLORIDA 33174
TEL. (305) 264-8100 FAX. (305) 262-6978
FENCES\10-02WB

PVC PRIVACY FENCE SYSTEMS
WESTECH BUILDING PRODUCTS, INC.
7451 HIGHWAY 62 EAST
MOUNT VERNON, INDIANA. 47620
TEL. (812) 985-3628 FAX. (812) 985-2925

Revisions:

| no | date | by | description |
|----|----------|------------------------|-------------|
| A | 09.02.10 | REV. PER BCCO COMMENTS | |
| B | 06.06.12 | NO CHANGE THIS SHEET | |

date: 04-09-10
scale: 1/4" = 1"
dr. by: HAMID
chk. by:

drawing no.
10-02

sheet 7 of 9

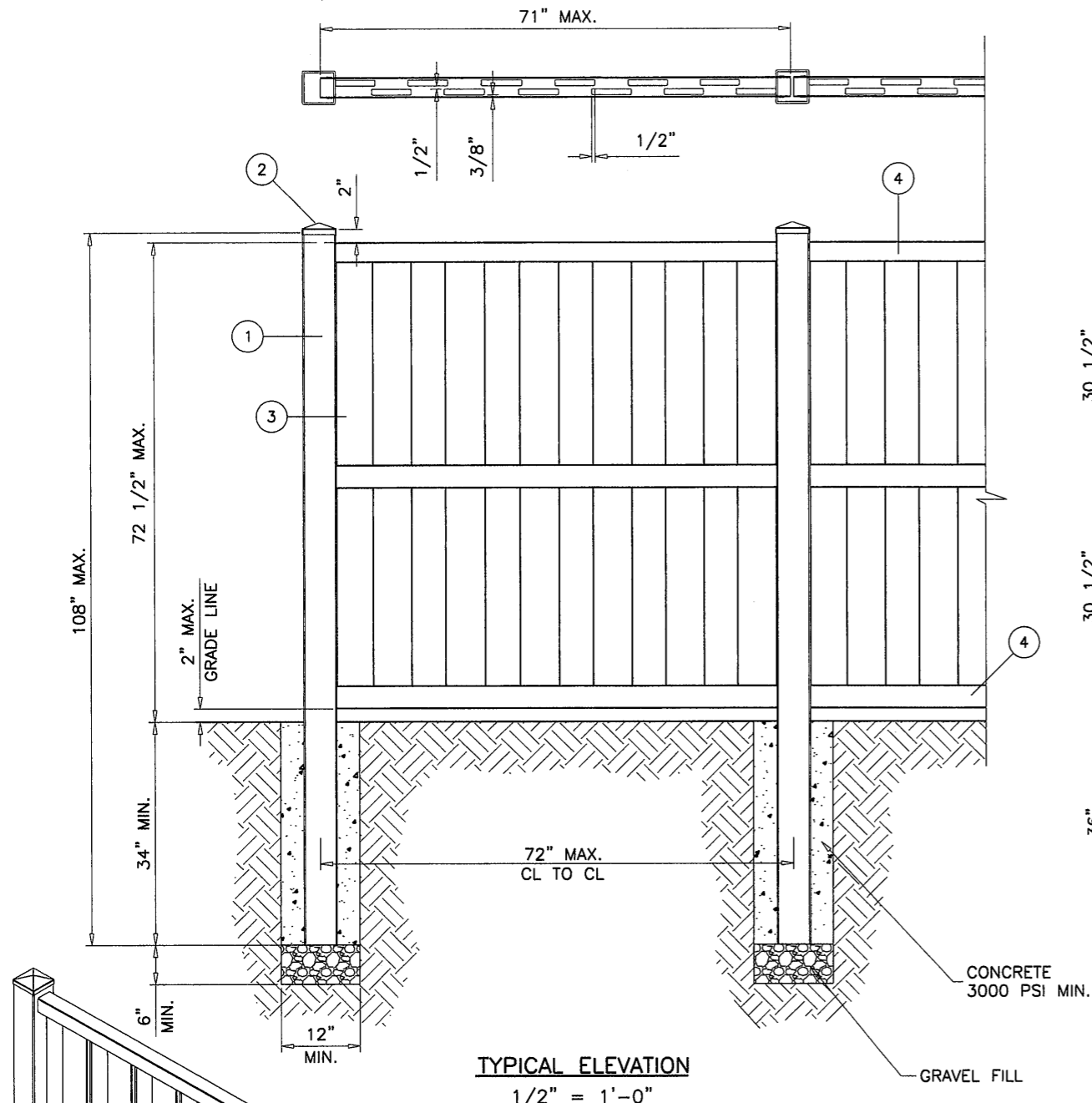

TYPICAL ELEVATION
1/2" = 1'-0"

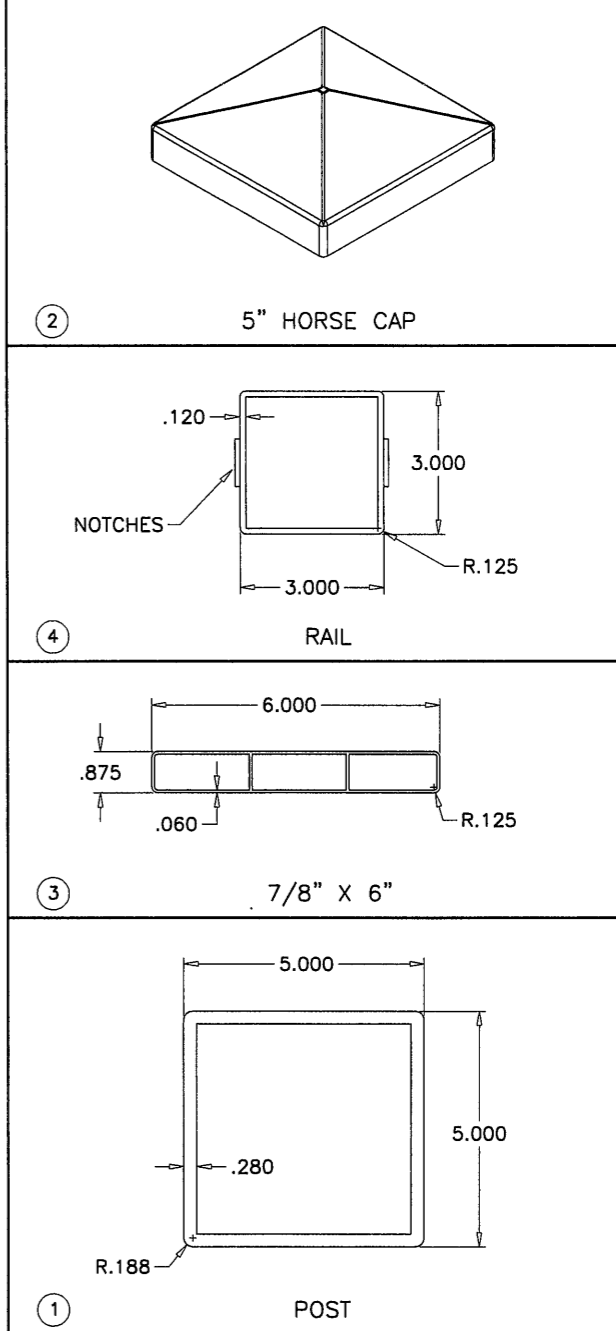
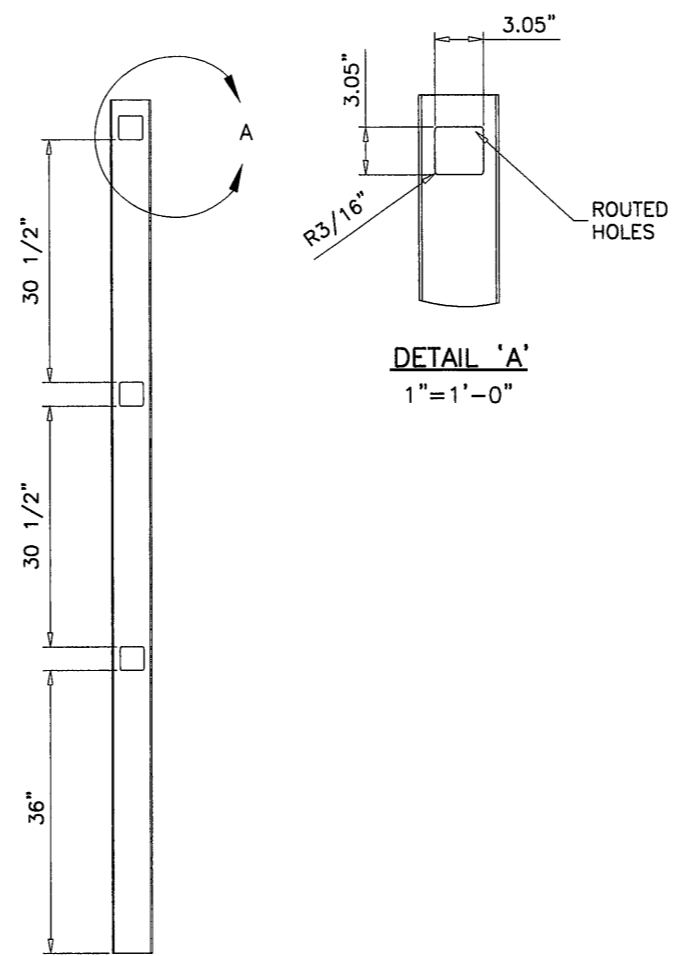
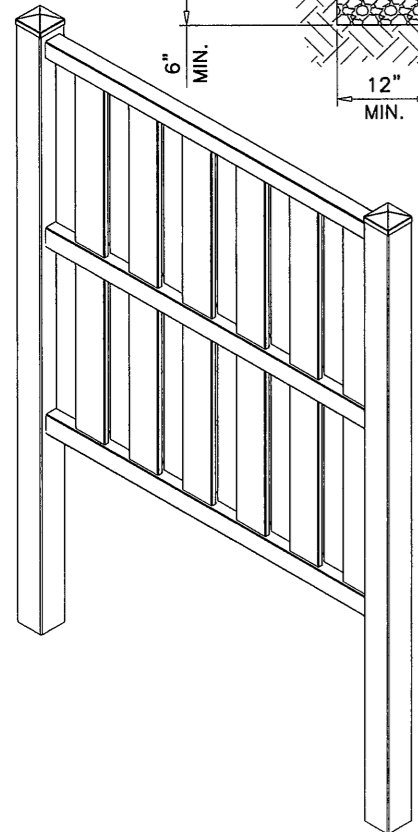

SHADOW BOX FENCE

| ITEM NO. | PART DESCRIPTION | LENGTH IN. |
|----------|------------------|------------|
| 1 | 5" X 5" POST | 108 |
| 2 | 5" HORSE CAP | N/A |
| 3 | 7/8" X 6" | 69-1/2 |
| 4 | 3" X 3" RAIL | 71 |

Engr: JAVAD AHMAD
CIVIL
FLA. PE # 70592
C.A.N. 3538

JA

JUN 07 2012

PRODUCT REVISED
as complying with the Florida
Building Code
Acceptance No. 12-0612-22
Expiration Date 10/06/2015

By *[Signature]*
Miami Dade Product Control

AL-FAROOQ CORPORATION
ENGINEERS & PRODUCT DEVELOPMENT
1235 S.W. 87 AVE
MIAMI, FLORIDA 33174
TEL. (305) 264-8100 FAX. (305) 262-6978

AFC

PVC PRIVACY FENCE SYSTEMS
WESTECH BUILDING PRODUCTS, INC.
7451 HIGHWAY 62 EAST
MOUNT VERNON, INDIANA, 47620
TEL. (812) 985-3628 FAX. (812) 985-2925

Revisions:

| no | date | by | description |
|----|----------|---------------|-------------|
| A | 09.02.10 | REV. PER BCCO | COMMENTS |
| B | 06.06.12 | NO CHANGE | THIS SHEET |

date: 04-09-10
scale: 1/4" = 1"
dr. by: HAMID
chk. by:

drawing no.
10-02

sheet 8 of 9

FENCES\10-02WB

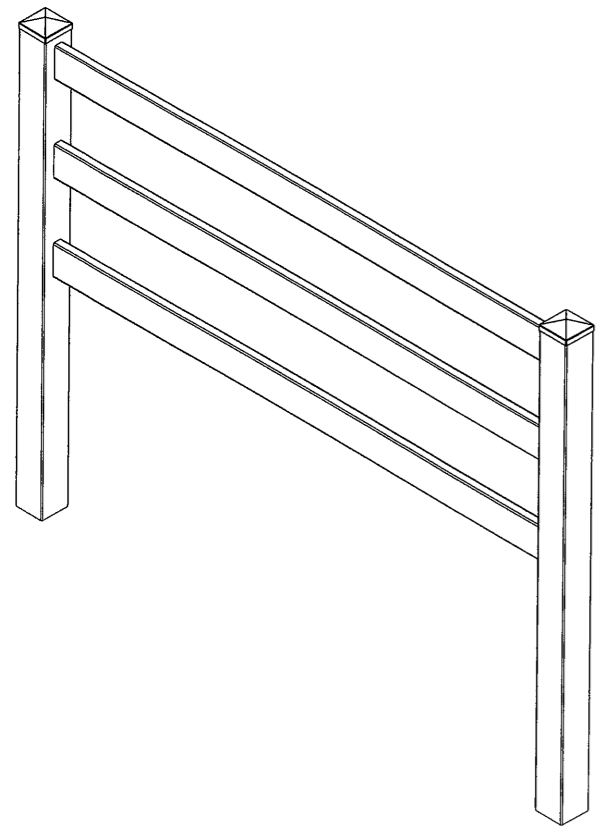
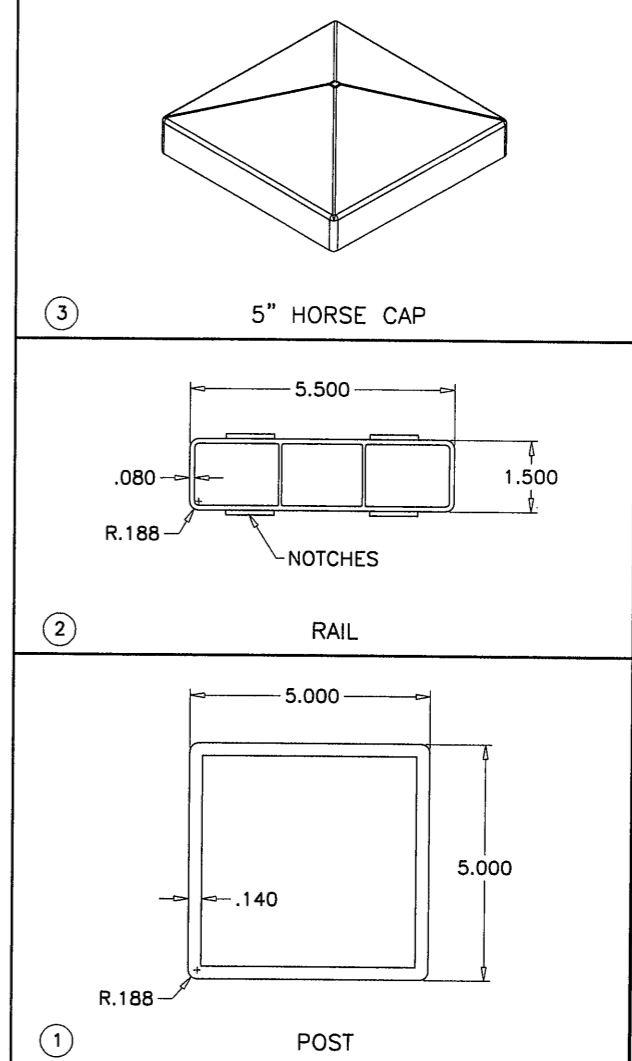
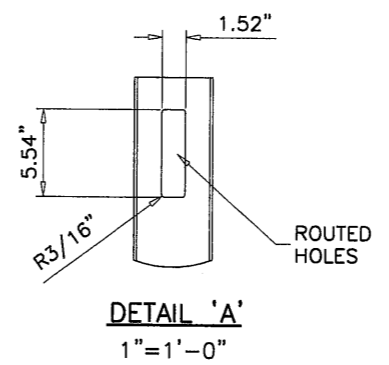
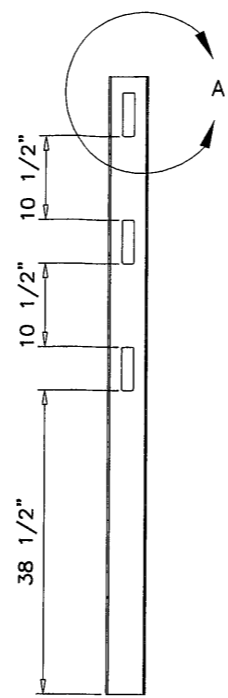
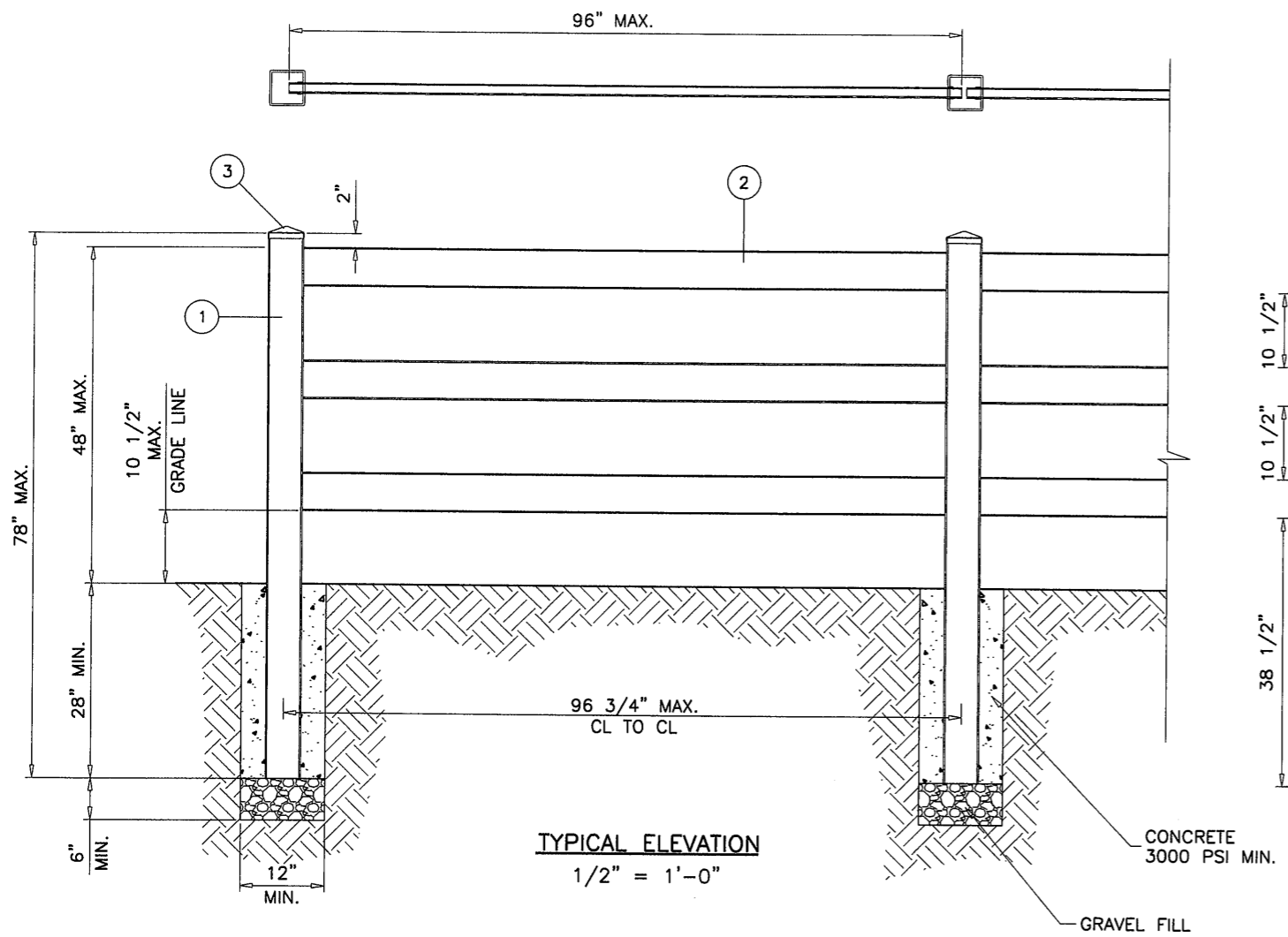

3 RAIL RANCH FENCE

| ITEM NO. | PART DESCRIPTION | LENGTH IN. |
|----------|----------------------|------------|
| 1 | 5" X 5" POST | 78 |
| 2 | 1-1/2" X 5-1/2" RAIL | 96 |
| 3 | 5" HORSE CAP | N/A |

Engr: JAVAD AHMAD
 CIVIL
 FLA. PE # 70592
 C.A.N. 3538

J.A.
 JUN 07 2012

PRODUCT REVISED
 as complying with the Florida
 Building Code
 Acceptance No 12-0612.22
 Expiration Date 10/06/2015
 By *Healy A. Miller*
 Miami Dade Product Control

AL-FAROOQ CORPORATION
 ENGINEERS & PRODUCT DEVELOPMENT
 1235 S.W. 87 AVE
 MIAMI, FLORIDA 33174
 TEL. (305) 264-8100 FAX. (305) 262-6978
 FENCES\10-02WBP

WESTECH BUILDING PRODUCTS, INC.
 7451 HIGHWAY 62 EAST
 MOUNT VERNON, INDIANA 47620
 TEL. (812) 985-3628 FAX. (812) 985-2925

PVC PRIVACY FENCE SYSTEMS

| no | date | description | by |
|----|----------|------------------------|----|
| A | 09.02.10 | REV. PER BCCO COMMENTS | |
| B | 06.06.12 | NO CHANGE THIS SHEET | |

date: 04-09-10
 scale: 1/4" = 1"
 dr. by: HAMID
 chk. by:

drawing no.
10-02

sheet 9 of 9