



DEPARTMENT OF REGULATORY AND ECONOMIC RESOURCES (RER)  
BOARD AND CODE ADMINISTRATION DIVISION

**NOTICE OF ACCEPTANCE (NOA)**

MIAMI-DADE COUNTY  
PRODUCT CONTROL SECTION  
11805 SW 26 Street, Room 208  
Miami, Florida 33175-2474  
T (786)315-2590 F (786) 315-2599

[www.miamidade.gov/economy](http://www.miamidade.gov/economy)

**Bartile Roofs, Inc.**  
725 North 1000 West  
Centerville, Utah

**SCOPE:**

This NOA is being issued under the applicable rules and regulations governing the use of construction materials. The documentation submitted has been reviewed and accepted by Miami-Dade County RER -Product Control Section to be used in Miami Dade County and other areas where allowed by the Authority Having Jurisdiction (AHJ).

This NOA shall not be valid after the expiration date stated below. The Miami-Dade County Product Control Section (In Miami Dade County) and/or the AHJ (in areas other than Miami Dade County) reserve the right to have this product or material tested for quality assurance purposes. If this product or material fails to perform in the accepted manner, the manufacturer will incur the expense of such testing and the AHJ may immediately revoke, modify, or suspend the use of such product or material within their jurisdiction. RER reserves the right to revoke this acceptance, if it is determined by Miami-Dade County Product Control Section that this product or material fails to meet the requirements of the applicable building code.

This product is approved as described herein, and has been designed to comply with the Florida Building Code including the High Velocity Hurricane Zone of the Florida Building Code.

**DESCRIPTION: Bartile Standard Weight Legendary Concrete Roof Tile**

**LABELING:** Each unit shall bear a permanent label with the manufacturer's name or logo, city, state and following statement: "Miami-Dade County Product Control Approved", unless otherwise noted herein.

**RENEWAL** of this NOA shall be considered after a renewal application has been filed and there has been no change in the applicable building code negatively affecting the performance of this product.

**TERMINATION** of this NOA will occur after the expiration date or if there has been a revision or change in the materials, use, and/or manufacture of the product or process. Misuse of this NOA as an endorsement of any product, for sales, advertising or any other purposes shall automatically terminate this NOA. Failure to comply with any section of this NOA shall be cause for termination and removal of NOA.

**ADVERTISEMENT:** The NOA number preceded by the words Miami-Dade County, Florida, and followed by the expiration date may be displayed in advertising literature. If any portion of the NOA is displayed, then it shall be done in its entirety.

**INSPECTION:** A copy of this entire NOA shall be provided to the user by the manufacturer or its distributors and shall be available for inspection at the job site at the request of the Building Official.

This NOA consists of pages 1 through 7.  
The submitted documentation was reviewed by Juan E. Collao, R.A.



NOA No.: 13-0321.09  
Expiration Date: 12/19/18  
Approval Date: 12/19/13  
Page 1 of 7

## ROOFING ASSEMBLY APPROVAL

**Category:** Roofing  
**Sub-Category:** Roofing Tiles  
**Material:** Concrete  
**Deck Type:** Wood

### 1. SCOPE

This NOA approves a system using **Legendary Roof Tile**, as manufactured **Bartile Roofs, Inc.** in Centerville, UT and described in Section 2 of this Notice of Acceptance. For locations where the pressure requirements, as determined by applicable Building Code does not exceed the design pressure values obtained by calculations in compliance with RAS 127 using the values listed in section 4 herein. The attachment calculations shall be done as a moment based system.

### 2. PRODUCT DESCRIPTION

<u>Manufactured by Applicant</u>	<u>Dimensions</u>	<u>Test Specifications</u>	<u>Product Description</u>
Bartile Standard Weight Legendary Concrete Roof Tile	L = 16" W = 16" H: 1.35"	TAS 101 TAS 112	Flat profile, interlocking, concrete roof tile with a smooth surface (Slate) or finely grooved surface (Split Timber) finish. For direct deck or adhesive set applications.
Trim Pieces	L = varies W = varies varying thickness	TAS 112	Accessory trim, concrete roof pieces for use at hips, rakes, ridges and valley terminations. Manufactured for each tile profile.

#### 2.1. MANUFACTURING LOCATION

2.1.1. Centerville, UT

#### 2.2. EVIDENCE SUBMITTED

<u>Test Agency</u>	<u>Test Identifier</u>	<u>Test Name/Report</u>	<u>Date</u>
Ronald Owaga & Associates	RIO-2399-13	TAS 101	02/01/13
	RIO-2366A-12	TAS 101	12/02/13
	RIO-2356-12A	TAS 112	12/05/13
	Letter	ASTM E 108	07/30/12
Ramtech Laboratories	3266-12-06 (A)	ASTM (E108-07a)	12/02/13



NOA No.: 13-0321.09  
Expiration Date: 12/19/18  
Approval Date: 12/19/13  
Page 2 of 7

### 3. LIMITATIONS

- 3.1 Fire classification is not part of this acceptance.
- 3.2 For mortar or adhesive set tile applications, a static field uplift test shall be performed in accordance with TAS 106.
- 3.3 Applicant shall retain the services of a Miami-Dade County Certified Laboratory to perform quarterly test in accordance with TAS 112, appendix 'A'. Such testing shall be submitted to the Miami-Dade Product Control office for review.
- 3.4 Minimum underlayment shall be in compliance with the applicable Roofing Applications Standards listed section 4.1 herein.
- 3.5 30/90 hot mopped underlayment applications may be installed perpendicular to the roof slope unless stated otherwise by the underlayment material manufacturers published literature.
- 3.6 This acceptance is for wood deck applications. Minimum deck requirements shall be in compliance with applicable building code.
- 3.7 All products listed herein shall have a quality assurance audit in accordance with the Florida Building Code and Rule 9N-3 of the Florida Administrative Code.

### 4. INSTALLATION

- 4.1 Bartile Legendary Roof Tile and its components shall be installed in strict compliance with Roofing Application Standard RAS 120.
- 4.2 Data For Attachment Calculations

**Table 1: Average Weight (W) and Dimensions (l x w)**

Tile Profile	Weight-W (lbf)	Length - l (feet)	Width-w (feet)
Bartile Legendary	14.00	1.333	1.333

**Table 2: Aerodynamic Multipliers -  $\lambda$  (ft<sup>3</sup>)**

Tile Profile	$\lambda$ (ft <sup>3</sup> )	
	Direct Deck Application	Batten Application
Bartile Legendary	0.36	N/A

**Table 3: Restoring Moments due to Gravity - M<sub>g</sub> (ft-lbf)**

Tile Profile	3":12"	4":12"	5":12"	6":12"	7":12" or greater
	Direct Deck	Direct Deck	Direct Deck	Direct Deck	Direct Deck
Bartile Legendary	10.2	9.97	9.7	9.4	9.1

**Table 5: Attachment Resistance Expressed as a Moment M<sub>f</sub> (ft-lbf)  
For Two Patty Adhesive Set Systems**

Tile Profile	Tile Application	Minimum Attachment Resistance
Bartile Legendary	Adhesive	84.04 <sup>1</sup>

<sup>1</sup> 3M™ 2-Component Foam Roof Tile Adhesive AH-160, average weight per patty 25.48 grams.



## 5. LABELING

All tiles shall bear the imprint or identifiable marking of the manufacturer's name or logo as seen below or following statement: "Miami-Dade County Product Control Approved".

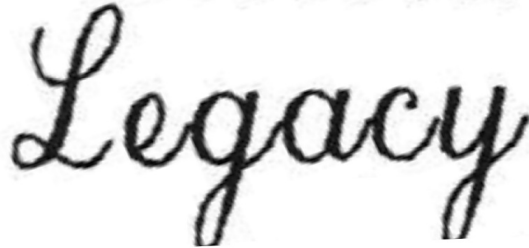

**'BARTILE LEGENDARY CONCRETE ROOF TILE' LABEL  
(LOCATED UNDERNEATH OF TILE)**

## 6. BUILDING PERMIT REQUIREMENTS:

- 6.1 Application for building permit shall be accompanied by copies of the following:
  - 6.1.1 This Notice of Acceptance.
  - 6.1.2 Any other documents required by Building Official or Applicable building code in order to properly evaluate the installation of this system.



## PROFILE DRAWINGS

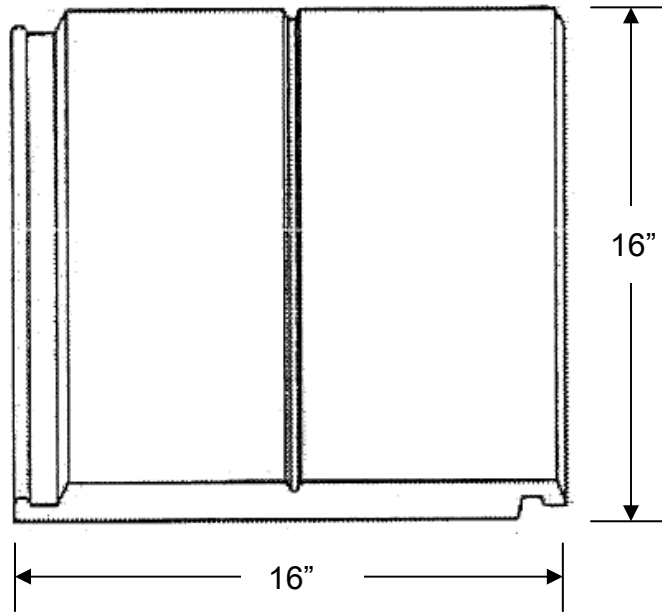

**'BARTILE LEGENDARY CONCRETE ROOF TILE'  
SMOOTH SURFACE (SLATE)**

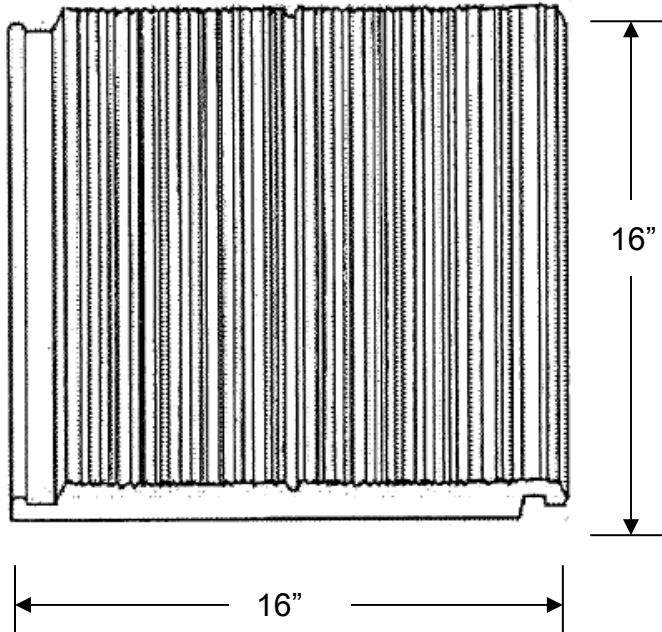

**'BARTILE LEGENDARY CONCRETE ROOF TILE'  
FINELY GROOVED SURFACE (SPLIT TIMBER)**

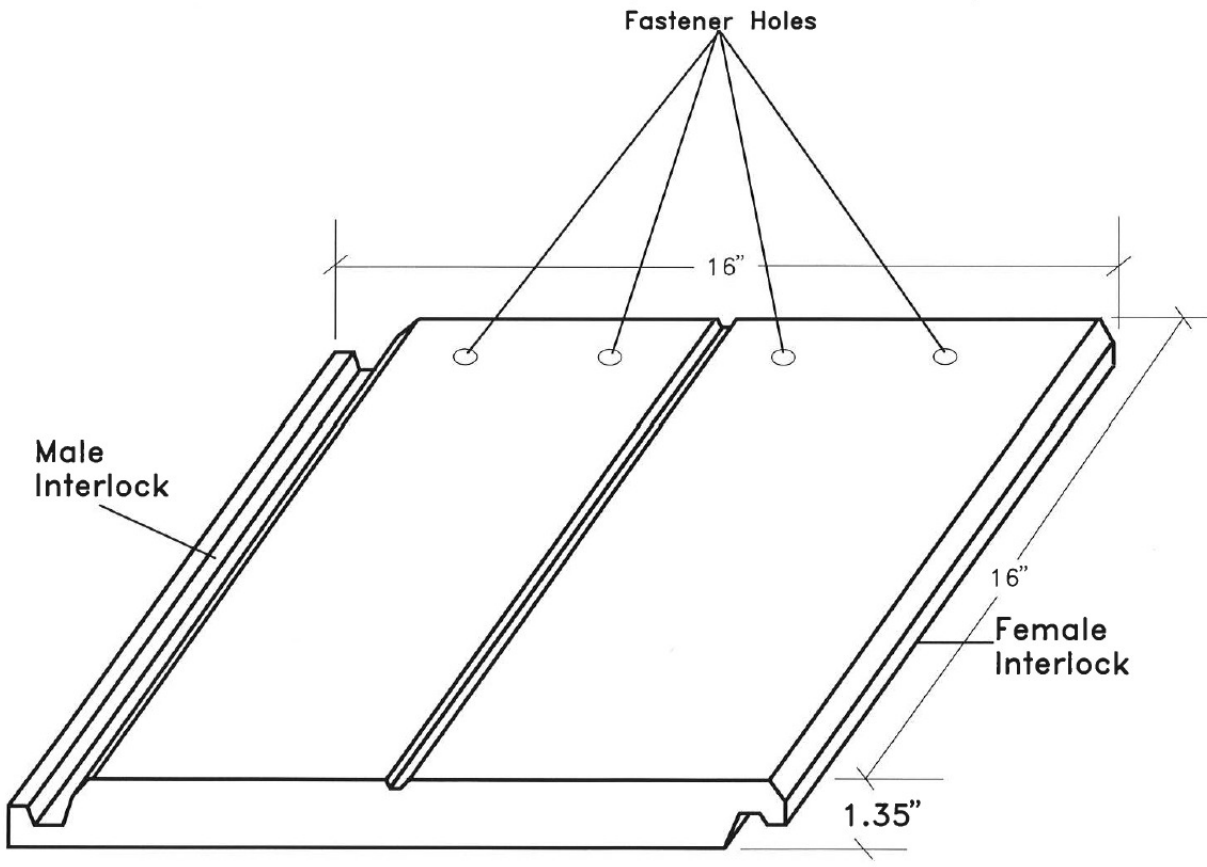

**‘BARTILE LEGENDARY CONCRETE ROOF TILE’**



**'BARTILE LEGENDARY CONCRETE ROOF TILE'**  
**UNDERSIDE OF TILE**  
**DOUBLE PATTY ADHESIVE PLACEMENT**

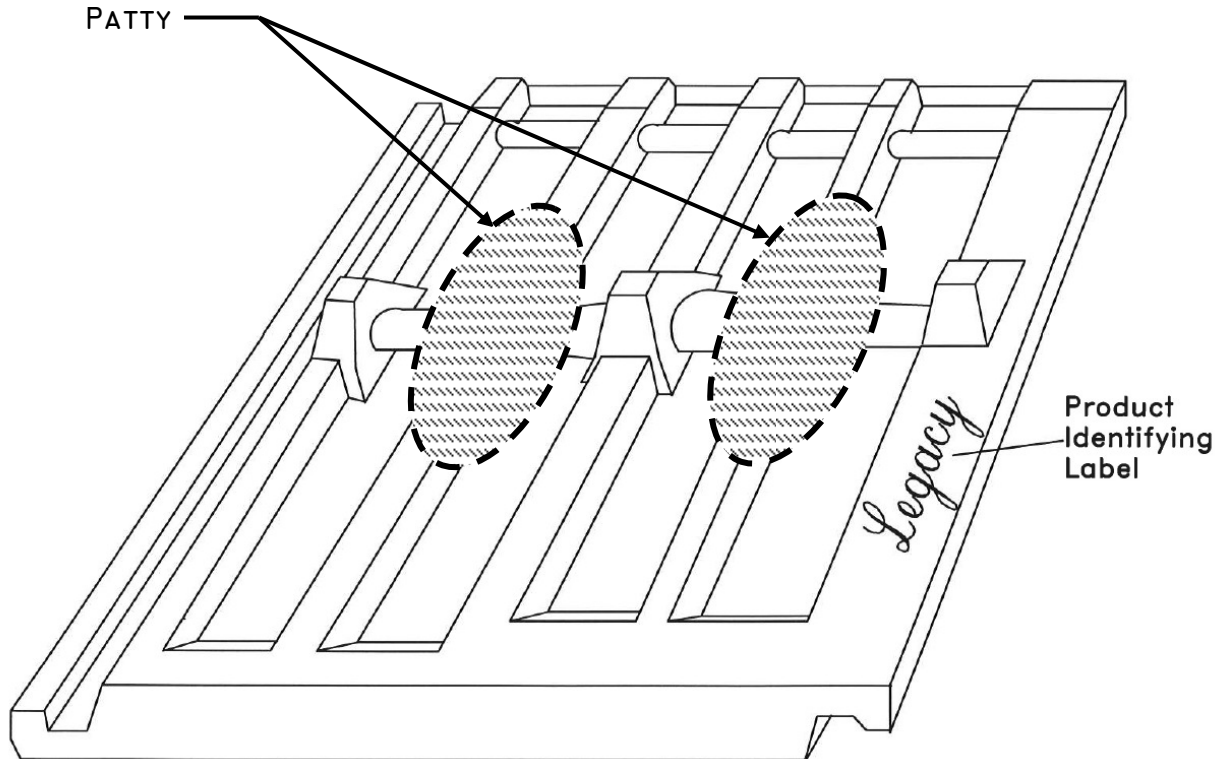

**END OF THIS ACCEPTANCE**