



DEPARTMENT OF REGULATORY AND ECONOMIC RESOURCES (RER)
BOARD AND CODE ADMINISTRATION DIVISION

MIAMI-DADE COUNTY
PRODUCT CONTROL SECTION
11805 SW 26 Street, Room 208
Miami, Florida 33175-2474
T (786) 315-2590 F (786) 315-2599
www.miamidade.gov/economy

NOTICE OF ACCEPTANCE (NOA)

Petersen Aluminum Corporation
1005 Tonne Road
Elk Grove Village, IL. 60007

SCOPE:

This NOA is being issued under the applicable rules and regulations governing the use of construction materials. The documentation submitted has been reviewed and accepted by Miami-Dade County RER - Product Control Section to be used in Miami Dade County and other areas where allowed by the Authority Having Jurisdiction (AHJ).

This NOA shall not be valid after the expiration date stated below. The Miami-Dade County Product Control Section (In Miami Dade County) and/or the AHJ (in areas other than Miami Dade County) reserve the right to have this product or material tested for quality assurance purposes. If this product or material fails to perform in the accepted manner, the manufacturer will incur the expense of such testing and the AHJ may immediately revoke, modify, or suspend the use of such product or material within their jurisdiction. RER reserves the right to revoke this acceptance, if it is determined by Miami-Dade County Product Control Section that this product or material fails to meet the requirements of the applicable building code.

This product is approved as described herein, and has been designed to comply with the Florida Building Code including the High Velocity Hurricane Zone of the Florida Building Code.

DESCRIPTION: Petersen Roof Edge Termination Systems

LABELING: Each unit shall bear a permanent label with the manufacturer's name or logo, city, state and following statement: "Miami-Dade County Product Control Approved", unless otherwise noted herein.

RENEWAL of this NOA shall be considered after a renewal application has been filed and there has been no change in the applicable building code negatively affecting the performance of this product.

TERMINATION of this NOA will occur after the expiration date or if there has been a revision or change in the materials, use, and/or manufacture of the product or process. Misuse of this NOA as an endorsement of any product, for sales, advertising or any other purposes shall automatically terminate this NOA. Failure to comply with any section of this NOA shall be cause for termination and removal of NOA.

ADVERTISEMENT: The NOA number preceded by the words Miami-Dade County, Florida, and followed by the expiration date may be displayed in advertising literature. If any portion of the NOA is displayed, then it shall be done in its entirety.

INSPECTION: A copy of this entire NOA shall be provided to the user by the manufacturer or its distributors and shall be available for inspection at the job site at the request of the Building Official.

This renews NOA#11-1222.06 and consists of pages 1 through 6.
The submitted documentation was reviewed by Alex Tigera.



NOA No.: 13-0909.15
Expiration Date: 12/11/18
Approval Date: 11/14/13
Page 1 of 6

ROOFING COMPONENT APPROVAL

Category: Roofing
Sub-Category: Roofing Fasteners
Materials: Steel / Aluminum

SCOPE:

This approves roofing components “**Petersen Roof Edge Termination Systems**” as described in this Notice of Acceptance. Designed to comply with the Florida Building Code and the High Velocity Hurricane Zone of the Florida Building Code for the locations where the pressure requirements, as determined by applicable building code do not exceed the design pressure values listed herein.

TRADE NAMES OF PRODUCTS MANUFACTURED OR LABELED BY APPLICANT:

Table 1

<u>Product Name</u>	<u>Dimensions</u>	<u>Test Specification</u>	<u>Product Description</u>
Pac-Tite Angular Fascia Single Ply & Built-Up or Modified Versions	Max. 8.5” Outside Face Min. Thickness 0.0276” Galvanized Steel or Max. Length 12’	TAS 111 (B)	Decorative metal fascia with continuous extruded aluminum bar.
Pac-Tite WT Extended Fascia-Single Ply & Built-Up or Modified Version	Max. 13” Outside Face Min. Thickness 0.050” aluminum Max. Length 12’	TAS 111 (B)	Decorative metal fascia with continuous extruded aluminum bar.
Pac-Tite Coping	Max. 6” Outside Face Max. 3.5” Inside Face Max. width 14” wall Min Thickness. 0.050 Aluminum Anchor clips: 0.0396 inch galvanized steel Max. Length 12’	TAS 111 (C)	Decorative Metal coping cap with galvanized steel anchor/support cleats

EVIDENCE SUBMITTED:

<u>Test Agency</u>	<u>Test Identifier</u>	<u>Test Name/Report</u>	<u>Date</u>
Intertek ETL Semko	3032125	TAS 111(B)	10/31/02
		TAS 111(C)	10/31/02
	3033767	TAS 111 (B)	10/31/02
	3033767 Addendum	TAS 111 (B)	10/02/03

MANUFACTURING LOCATION

1. Waukesha, WI.



NOA No.: 13-0909.15
Expiration Date: 12/11/18
Approval Date: 11/14/13
Page 2 of 6

INSTALLATION:

Pac-Tite Angular Fascia Single Ply & Built-Up or Modified Versions:

The top portion of the anchor bar shall be fastened with a minimum #12 x 1-⁵/₈" hex head screws spaced 12 inches o.c. secured to the top nailer, (see detail "A" herein).

Maximum Design Pressure: -145psf

Pac-Tite WT Extended Fascia-Single Ply & Built-Up or Modified Version:

The top portion of the anchor bar shall be fastened with a minimum #12 x 1-⁵/₈" hex head screws with washers spaced 12 inches o.c. secured to the top nailer, (see detail "B" herein). The lower portion of the anchor bar shall be fastened with 1/4" x 1- 1/4" hex head screw spaced 24 into underlying substrate (see detail "B" herein).

Maximum Design Pressure: -95 psf

Pac-Tite Coping:

Perma-Tite Anchor clips shall be spaced a maximum of three feet o.c. Anchor clips shall be fastened with #12 x 1-⁵/₈" hex head screws fastened through the third hole of the top portion of the anchor clip the side where the stainless-steel spring clip is located (see detail "C" herein). And with two additional 1-1/4" annular ring shank nail fastened in the provided holes on the opposite face at a maximum of 3" up from the bottom lip (see detail "C" herein).

Maximum Design Pressure: -84 psf



LIMITATIONS:

1. All products listed herein shall be installed in accordance with the requirements set forth in RAS 111.
2. Maximum dimensions shall be as outlined in Table 1 herein.
3. All products listed herein shall be installed in conjunction with Petersen Aluminum Corporation’s required accessories including but not limited to: miters, splice caps, splice plates, corners, end caps, pier caps, etc.
4. Downspout scuppers, spillout scuppers shall be fabricated and installed in accordance with RAS 111.
5. If required, install water cut-off as recommended by the membrane manufacturer and under the anchor bar.
6. Contractor shall check as-built conditions and verify roof edge details for accuracy to fit as built conditions prior to installation. Installer shall comply with Petersen Aluminum Corporation’s published installation requirements.
7. Fasteners shall be Petersen Aluminum Corporation’s approved fasteners.
8. Fasteners shall provide a minimum pull out resistance of 240lbf (109 kg) into the substrate being fastened into. When tested in accordance with TAS 105.
9. No exposed fasteners shall be permitted.
10. All fasteners shall be of compatible materials.
11. Finishes shall be natural aluminum mill finish, or pre-coated Kynar 500. All coatings shall be in compliance with the Florida Building Code (FBC).
12. The maximum design pressures listed here in are applicable to the perimeter areas of the roof. Increased design pressures for corner areas, in compliance with applicable building code may be met through rational analysis by increasing the number of attachment points in these areas. The maximum fastener spacing noted in the “Systems Description” section of this approval shall not be exceeded. All rational analysis computations shall be prepared, signed and sealed by a Florida Registered Professional Engineer, Registered Architect, or Registered Roof Consultant.
13. All products listed herein shall have a quality assurance audit in accordance with the Florida Building Code and Rule 9N-3 of the Florida Administrative Code.
14. All approved products listed herein shall be labeled and shall bear the imprint or identifiable marking of the manufacturer's name or logo and following statement: "Miami-Dade County Product Control Approved" or the Miami-Dade County Product Control Seal as shown below



DETAIL A

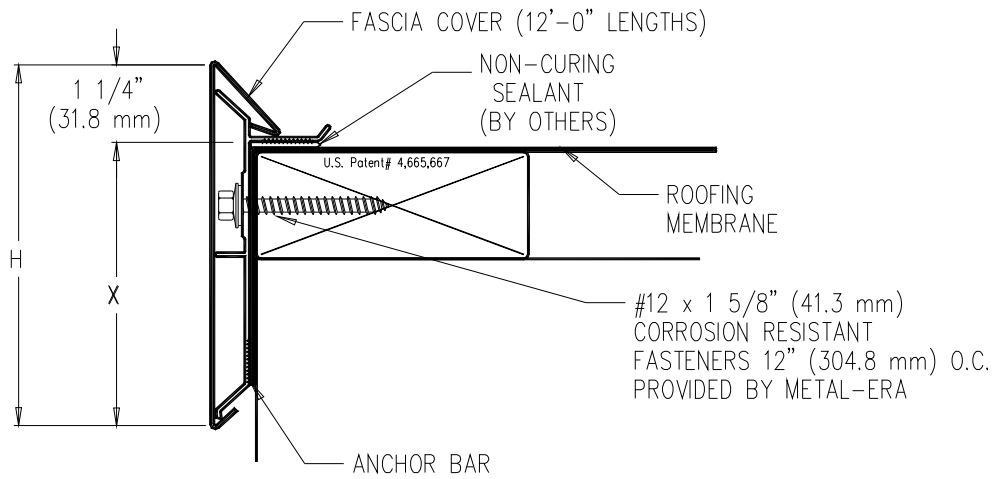

DETAIL B

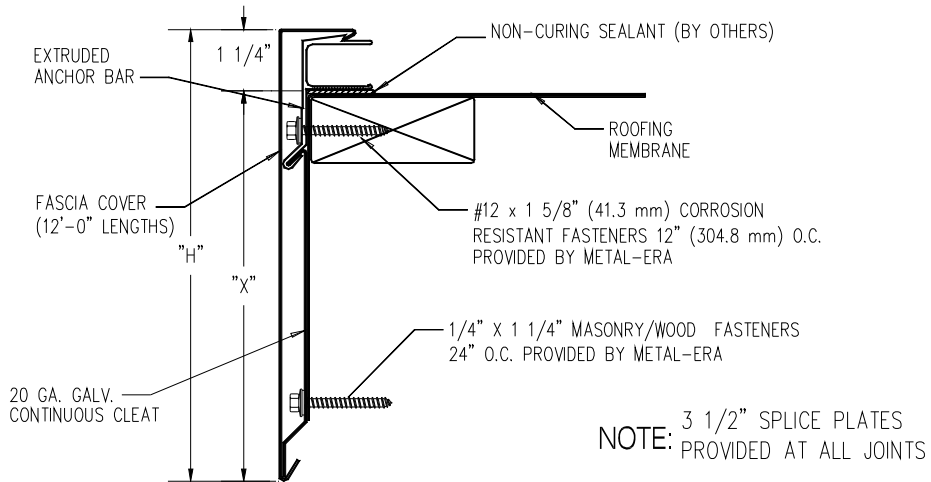

DETAIL C

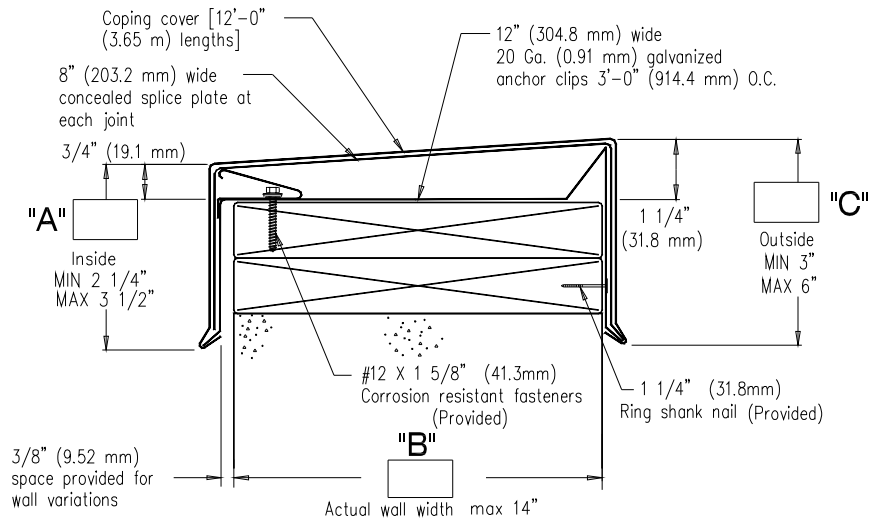

END OF THIS ACCEPTANCE

