



DEPARTMENT OF REGULATORY AND ECONOMIC RESOURCES (RER)  
BOARD AND CODE ADMINISTRATION DIVISION

**NOTICE OF ACCEPTANCE (NOA)**

MIAMI-DADE COUNTY  
PRODUCT CONTROL SECTION  
11805 SW 26 Street, Room 208  
Miami, Florida 33175-2474  
T (786)315-2590 F (786) 315-2599

[www.miamidade.gov/economy](http://www.miamidade.gov/economy)

**Entegra Roof Tile, LLC**  
1289 NE 9<sup>th</sup> Ave  
Okeechobee, FL. 34972

**SCOPE:**

This NOA is being issued under the applicable rules and regulations governing the use of construction materials. The documentation submitted has been reviewed and accepted by Miami-Dade County RER -Product Control Section to be used in Miami Dade County and other areas where allowed by the Authority Having Jurisdiction (AHJ).

This NOA shall not be valid after the expiration date stated below. The Miami-Dade County Product Control Section (In Miami Dade County) and/or the AHJ (in areas other than Miami Dade County) reserve the right to have this product or material tested for quality assurance purposes. If this product or material fails to perform in the accepted manner, the manufacturer will incur the expense of such testing and the AHJ may immediately revoke, modify, or suspend the use of such product or material within their jurisdiction. RER reserves the right to revoke this acceptance, if it is determined by Miami-Dade County Product Control Section that this product or material fails to meet the requirements of the applicable building code.

This product is approved as described herein, and has been designed to comply with the Florida Building Code including the High Velocity Hurricane Zone of the Florida Building Code.

**DESCRIPTION: Galena Spanish "S" Concrete Roof Tile**

**LABELING:** Each unit shall bear a permanent label with the manufacturer's name or logo, city, state and following statement: "Miami-Dade County Product Control Approved", unless otherwise noted herein.

**RENEWAL** of this NOA shall be considered after a renewal application has been filed and there has been no change in the applicable building code negatively affecting the performance of this product.

**TERMINATION** of this NOA will occur after the expiration date or if there has been a revision or change in the materials, use, and/or manufacture of the product or process. Misuse of this NOA as an endorsement of any product, for sales, advertising or any other purposes shall automatically terminate this NOA. Failure to comply with any section of this NOA shall be cause for termination and removal of NOA.

**ADVERTISEMENT:** The NOA number preceded by the words Miami-Dade County, Florida, and followed by the expiration date may be displayed in advertising literature. If any portion of the NOA is displayed, then it shall be done in its entirety.

**INSPECTION:** A copy of this entire NOA shall be provided to the user by the manufacturer or its distributors and shall be available for inspection at the job site at the request of the Building Official.

This renews and revises NOA 10-0518.04 and consists of pages 1 through 6.  
The submitted documentation was reviewed by Juan E. Collao, R.A.



NOA No.: 14-0416.12  
Expiration Date: 11/18/19  
Approval Date: 11/27/14  
Page 1 of 6

## ROOFING ASSEMBLY APPROVAL

**Category:** Roofing  
**Sub-Category:** Roofing Tiles  
**Material:** Concrete

### 1. SCOPE

This approves a roofing system using **Galena Spanish “S” Concrete Roof Tile**, as manufactured by Entegra Roof Tile, LLC as described in Section 2 of this Notice of Acceptance, designed to comply with the Florida Building Code for High Velocity Hurricane Zone. For the locations where the pressure requirements, as determined by applicable Building Code, does not exceed the design pressure values obtain by calculations in compliance with RAS 127 using the values listed in section 4 herein. The attachment calculations shall be done as a moment based system.

### 2. PRODUCT DESCRIPTION

<u>Manufactured by Applicant</u>	<u>Dimensions</u>	<u>Test Specifications</u>	<u>Product Description</u>
Galena Spanish ‘S’ Roof Tile	L = 17" W = 10" H = 2.7” Thickness: ½”	TAS 112	High profile, interlocking, one-piece, “S” shaped, concrete roof tile equipped with two nail holes. For direct deck or battened nail-on, mortar or adhesive set applications.
Trim Pieces	L = varies W = varies Varying thickness	TAS 112	Accessory trim, concrete roof pieces for use at hips, rakes, ridges and valley terminations. Manufactured for each tile profile.

#### 2.1. MANUFACTURING LOCATION

1. Okeechobee, FL

#### 2.2. EVIDENCE SUBMITTED

<u>Test Agency</u>	<u>Test Identifier</u>	<u>Test Name/Report</u>	<u>Date</u>
Redland Technologies	7161-03 Appendix III	Static Uplift Testing PA 102 & PA 102(A)	Dec. 1991
Redland Technologies	7161-03 Appendix II	Wind Tunnel Testing PA 108 (Nail-On)	Dec. 1991
Redland Technologies	P0647-01	Wind Tunnel Testing PA 108 (Mortar Set)	Aug. 1994
Redland Technologies	P0402	Withdrawal Resistance Testing of screw vs. smooth shank nails	Sept. 1993
The Center for Applied Engineering, Inc.	94-084	Static Uplift Testing PA 101 (Mortar Set)	May 1994
The Center for Applied Engineering, Inc.	94-083	Static Uplift Testing PA 101 (Adhesive Set)	April 1994

<u>Test Agency</u>	<u>Test Identifier</u>	<u>Test Name/Report</u>	<u>Date</u>
The Center for Applied Engineering, Inc.	25-7183-4	Static Uplift Testing PA 102 (2 Quik-Drive Screws, Direct Deck)	Feb. 1995
The Center for Applied Engineering, Inc.	25-7214-3	Static Uplift Testing PA 102 (1 Quik-Drive Screw, Direct Deck)	March, 1995
Redland Technologies	Letter Dated Aug. 1, 1994	Wind Tunnel Testing PA 108 (Nail-On)	Aug. 1994
The Center for Applied Engineering, Inc.	Project No. 307025	Wind Driven Rain PA 100	Oct. 1994
Nutting Engineering	Test #MDC-78 13343.1	Physical Properties TAS 112	June 2007
Celotex Corporation Testing Service	520111-3 520191-2-1	Static Uplift Testing PA 101	Dec. 1998 March 1999
Walker Engineering, Inc.	Calculations	Two Patty Adhesive Set System	April 1999
Walker Engineering, Inc.	Evaluation Calculations	25-7094	February 1996
Walker Engineering, Inc.	Evaluation Calculations	25-7496	April 1996
Walker Engineering, Inc.	Evaluation Calculations	25-7584 25-7804b-8 25-7804-4 & 5 25-7848-6	December 1996
Walker Engineering, Inc.	Evaluation Calculations	25-7183	March 1995
Walker Engineering, Inc.	Evaluation Calculations	Restoring Moment Due to Gravity	09/14/09
Walker Engineering, Inc.	Calculations	Aerodynamic Multiplier	09/14/09
American Test Lab of South Florida	RT0624.04-14	TAS 112	07/07/14

### 3. LIMITATIONS

- 3.1 Fire classification is not part of this acceptance.
- 3.2 For mortar or adhesive set tile applications, a static field uplift test shall be performed in accordance with TAS 106.
- 3.3 Applicant shall retain the services of a Miami-Dade County Certified Laboratory to perform quarterly test in accordance with TAS 112, appendix 'A'. Such testing shall be submitted to the Miami-Dade Product Control office for review.
- 3.4 Minimum underlayment shall be in compliance with the applicable Roofing Applications Standards listed section 4.1 herein.
- 3.5 30/90 hot mopped underlayment applications may be installed perpendicular to the roof slope unless stated otherwise by the underlayment material manufacturers published literature.
- 3.6 This acceptance is for wood deck applications. Minimum deck requirements shall be in compliance with applicable building code.
- 3.7 All products listed herein shall have a quality assurance audit in accordance with the Florida Building Code and Rule 61G20-3 of the Florida Administrative Code.



#### 4. INSTALLATION

- 4.1 Galena Spanish "S" Concrete Roof Tile and its components shall be installed in strict compliance with Roofing Application Standard RAS 118, RAS 119 and RAS 120.
- 4.2 Data For Attachment Calculations

Table 1: Average Weight (W) and Dimensions (l x w )			
Tile Profile	Weight-W (lbf)	Length-l (ft)	Width-w (ft)
Galena Spanish 'S' Roof Tile	8.5	1.42	0.833

Table 2: Aerodynamic Multipliers - $\lambda$ (ft <sup>3</sup> )	
Tile Profile	$\lambda$ (ft <sup>3</sup> ) Direct Deck Application
Galena Spanish 'S' Roof Tile	0.235

Table 3: Restoring Moments due to Gravity - $M_g$ (ft-lbf)						
Tile Profile	2":12"	3":12"	4":12"	5":12"	6":12"	7":12" or greater
Galena Spanish 'S' Roof Tile	Direct Deck	Direct Deck	Direct Deck	Direct Deck	Direct Deck	Direct Deck
	6.20	6.13	6.03	5.89	5.74	5.57

Table 4: Attachment Resistance Expressed as a Moment - $M_f$ (ft-lbf) for Mechanically Attached Systems			
Tile Profile	Fastener Type	Direct Deck (min 15/32" plywood)	Direct Deck (min. 19/32" plywood)
Galena Spanish 'S' Roof Tile	2-10d Ring Shank Nails	28.6	41.2
	1-10d Smooth or Screw Shank Nail <sup>2</sup>	5.1	6.8
	2-10d Smooth or Screw Shank Nails	6.9	9.2
	1 #8 Screw <sup>2</sup>	20.7	20.7
	2 #8 Screw	43.2	43.2
	1-10d Smooth or Screw Shank Nail (Field Clip) <sup>2</sup>	23.1	23.1
	1-10d Smooth or Screw Shank Nail (Eave Clip) <sup>2</sup>	29.3	29.3
	2-10d Smooth or Screw Shank Nails (Field Clip)	27.6	27.6
	2-10d Smooth or Screw Shank Nails (Eave Clip)	38.1	38.1
	2-10d Ring Shank Nails <sup>1</sup>	33.1	48.1

1 Installation with a 4" tile headlap and fasteners are located a min. of 2 1/2" from head of tile.

2 When using only one fastener use the hole that is approximately 4 3/4" away from interlocking edge.



**Table 5: Attachment Resistance Expressed as a Moment  $M_f$  (ft-lbf)  
for Two Patty Adhesive Set Systems**

Tile Profile	Tile Application	Minimum Attachment Resistance
Galena Spanish 'S' Roof Tile	Adhesive	29.3 <sup>4</sup>
3 See manufacturer's component approval for installation requirements.		
4 The Dow Chemical Company TileBond Average weight per patty 10.7 grams. 3M™ 2-Component Foam Roof Tile Adhesive AH-160, average weight per patty 8 grams.		

**Table 6: Attachment Resistance Expressed as a Moment -  $M_f$  (ft-lbf)  
for Single Patty Adhesive Set Systems**

Tile Profile	Tile Application	Minimum Attachment Resistance
Galena Spanish 'S' Roof Tile	3M™ 2-Component Foam Roof Tile Adhesive AH-160	66.5 <sup>5</sup>
	3M™ 2-Component Foam Roof Tile Adhesive AH-160	38.7 <sup>6</sup>
5 Large paddy placement of 63 grams of 3M™ 2-Component Foam Roof Tile Adhesive AH-160.		
6 Medium paddy placement of 27 grams of 3M™ 2-Component Foam Roof Tile Adhesive AH-160.		

**Table 7: Attachment Resistance Expressed as a Moment -  $M_f$  (ft-lbf)  
for Mortar or Adhesive Set Systems**

Tile Profile	Tile Application	Minimum Attachment Resistance
Galena Spanish 'S' Roof Tile	Mortar Set	24.5

**5. LABELING**

All tiles shall bear the imprint or identifiable marking of the manufacturer's name or logo as seen below or following statement: "Miami-Dade County Product Control Approved".



OR

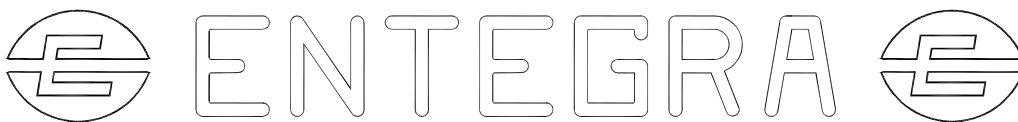

**GALENA SPANISH "S" CONCRETE ROOF TILE LABEL (LOCATED ON UNDERSIDE OF TILE)**



**6. BUILDING PERMIT REQUIREMENTS:**

6.1 Application for building permit shall be accompanied by copies of the following:

6.1.1 This Notice of Acceptance.

6.1.2 Any other documents required by Building Official or Applicable building code in order to properly evaluate the installation of this system.

**PROFILE DRAWINGS**

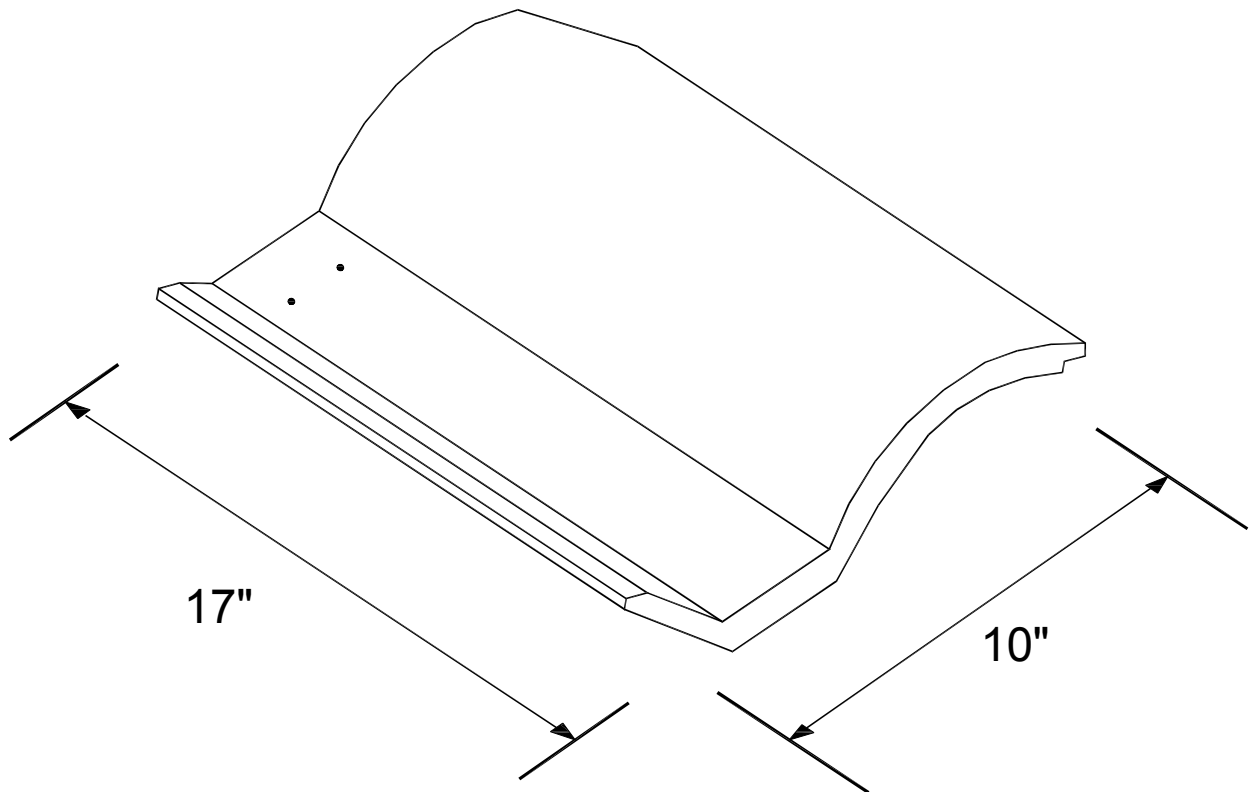

**GALENA SPANISH "S" CONCRETE ROOF TILE**

**END OF THIS ACCEPTANCE**

