



DEPARTMENT OF REGULATORY AND ECONOMIC RESOURCES (RER)
BOARD AND CODE ADMINISTRATION DIVISION

MIAMI-DADE COUNTY
PRODUCT CONTROL SECTION
11805 SW 26 Street, Room 208
Miami, Florida 33175-2474
T (786) 315-2590 F (786) 315-2599

www.miamidade.gov/economy

NOTICE OF ACCEPTANCE (NOA)

R & S Manufacturing and Sales Company, Inc.
3575 Old Conejo Road
Newbury Park, CA 91320-2122

SCOPE:

This NOA is being issued under the applicable rules and regulations governing the use of construction materials. The documentation submitted has been reviewed and accepted by Miami-Dade County RER-Product Control Section to be used in Miami Dade County and other areas where allowed by the Authority Having Jurisdiction (AHJ).

This NOA shall not be valid after the expiration date stated below. The Miami-Dade County Product Control Section (In Miami Dade County) and/or the AHJ (in areas other than Miami Dade County) reserve the right to have this product or material tested for quality assurance purposes. If this product or material fails to perform in the accepted manner, the manufacturer will incur the expense of such testing and the AHJ may immediately revoke, modify, or suspend the use of such product or material within their jurisdiction. RER reserves the right to revoke this acceptance, if it is determined by Miami-Dade County Product Control Section that this product or material fails to meet the requirements of the applicable building code.

This product is approved as described herein, and has been designed to comply with the High Velocity Hurricane Zone of the Florida Building Code.

DESCRIPTION: Model RS Self Flashing or Curb Mount Skylight Systems

APPROVAL DOCUMENT: Drawing No. SK - 7792, titled "Hurricane Rated Model RS Skylight" sheets 1 through 4 of 4, dated September 14, 2015, prepared by Richard Boyette Consulting, Inc., signed and sealed by Richard Boyette, P.E., bearing the Miami-Dade County Product Control Approval stamp with the Notice of Acceptance number and the approval date by the Miami-Dade County Product Control Section.

MISSILE IMPACT RATING: Large and Small Missile Impact Resistant

LABELING: Each unit shall bear a permanent label with the manufacturer's name or logo, city, state, and the following statement: "Miami-Dade County Product Control Approved", unless otherwise noted herein.

RENEWAL of this NOA shall be considered after a renewal application has been filed and there has been no change in the applicable building code negatively affecting the performance of this product.

TERMINATION of this NOA will occur after the expiration date or if there has been a revision or change in the materials, use, and/or manufacture of the product or process. Misuse of this NOA as an endorsement of any product, for sales, advertising or any other purposes shall automatically terminate this NOA. Failure to comply with any section of this NOA shall be cause for termination and removal of NOA.

ADVERTISEMENT: The NOA number preceded by the words Miami-Dade County, Florida, and followed by the expiration date may be displayed in advertising literature. If any portion of the NOA is displayed, then it shall be done in its entirety.

INSPECTION: A copy of this entire NOA shall be provided to the user by the manufacturer or its distributors and shall be available for inspection at the job site at the request of the Building Official.

This NOA consists of this page 1, evidence submitted page E-1 as well as approval document mentioned above. The submitted documentation was reviewed by **Helmy A. Makar, P.E., M.S.**

Helmy A. Makar
10/22/2015



NOA No. 14-0505.09
Expiration Date: 10/22/2020
Approval Date: 10/22/2015

R & S Manufacturing and Sales Company, Inc.

NOTICE OF ACCEPTANCE: EVIDENCE SUBMITTED

A. DRAWINGS

1. *Drawing No. SK - 7792, titled " Hurricane Rated Model RS Skylight " sheets 1 through 4 of 4, dated September 14, 2015, prepared by Richard Boyette Consulting, Inc., signed and sealed by Richard Boyette, P.E.*

B. TESTS

1. *Test report on Large Missile Impact Test per TAS 201, Cyclic Load Test per TAS 203, and Uniform Static air Pressure Test per TAS 202 on Model RS Skylight System, prepared by Intertek / Architectural Testing, Report No. E6691.01-301-18, dated 07/15/2015, signed and sealed by Tyler Westerling, P.E.*

C. CALCULATIONS

1. *Calculation titled " Fastener Loads – 60 PSF Lateral & Uplift ", 3 pages, dated 09/23/2015, signed and sealed by Richard Boyette, P.E.*

D. QUALITY ASSURANCE

1. *By Miami-Dade County Department of Regulatory and Economic Resources.*

E. MATERIAL CERTIFICATIONS

1. *None.*

F. OTHERS

1. *Compliance letter with the FBC, 2014 Edition, dated 09/23/15, prepared by Richard Boyette Consulting, Inc., signed and sealed by Richard Boyette, P.E.*

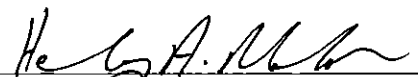

Kelny A. Makar, P.E., M.S.
Product Control Section Supervisor
NOA No. 14-0505.09
Expiration Date: 10/22/2020
Approval Date: 10/22/2015

NOTES:

HURRICANE RATED MODEL RS SKYLIGHT
 LARGE & SMALL MISSILE IMPACT RESISTANT - 2014 FBC HVHZ
 OUTER DOME FORMED WITH 0.118" LEXAN XL-10 POLYCARBONATE SHEETS
 DESIGN POSITIVE LOAD 40 PSF
 DESIGN NEGATIVE LOAD 60 PSF
 EXTRUDED ALUMINUM FRAME 6063-T6 MITERED AND WELDED AT CORNERS
 FABRICATED CURBS 0.080" 5052-H32 ALUMINUM MITERED AND WELDED AT CORNERS
 MAXIMUM OPENING DIMENSIONS 48" x 120"
 ALL UNITS EQUAL TO OR LESS THAN 48" x 120" ACCEPTED UNDER THIS NOA
 ROOFING DETAILS TO COMPLY WITH CHAPTER 15 OF THE 2014 FLORIDA BUILDING CODE
 4" MINIMUM DISTANCE IS REQUIRED FROM THE ANGLE LIP TO THE ROOF SURFACE

TABLE OF CONTENTS:

SHEET 1: NOTES, DESIGN RATINGS, COMPONENTS
 SHEET 2: SELF FLASHING 9" HIGH
 SHEET 3: METAL BUILDING 8" HIGH INSULATED
 SHEET 4: WOOD CURB MOUNT

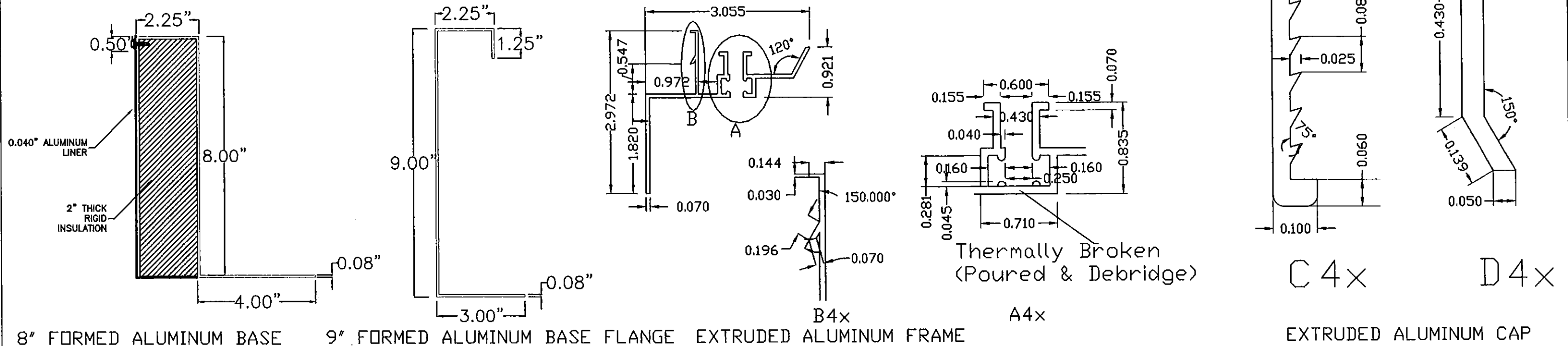

R&S MANUFACTURING AND SALES CO.

3575 Old Conejo Rd
 Newbury Park, CA
 (805)375-3980
 fax 375-3981

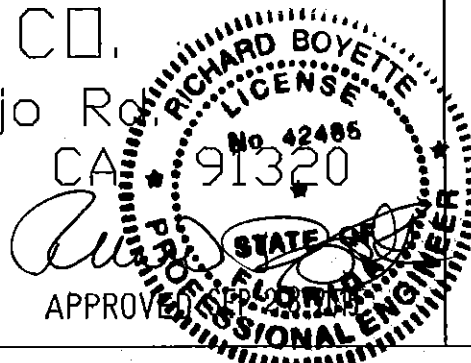

MIAMI-DADE PER:

Approved as complying with the Florida Building Code
 Date 10/22/2015
 NOA# 14-0505.09
 Miami Dade Product Control

By *Richard Boyette*

RICHARD BOYETTE
 FL PE #42485
 RICHARD BOYETTE CONSULTING, INC.
 COA #9707
 4031 COCONUT BLVD
 ROYAL PALM BEACH
 FL 33411
 561-790-5766

PRODUCT:

HURRICANE RATED MODEL RS SKYLIGHT

DATE
 9/14/15

SHEET:
 1 OF 4

SCALE
 NTS

DRAWING #
 SK-7792-1

SELF FLASHING 9" HIGH

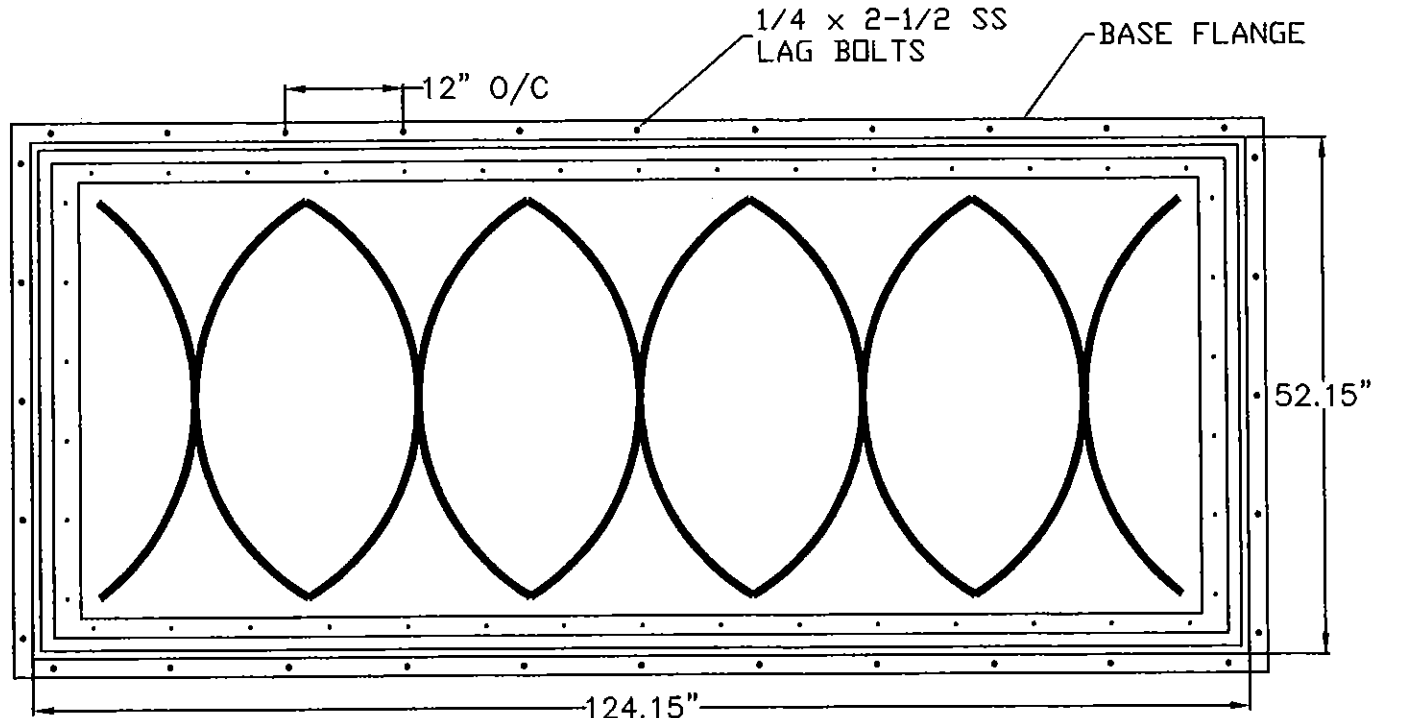
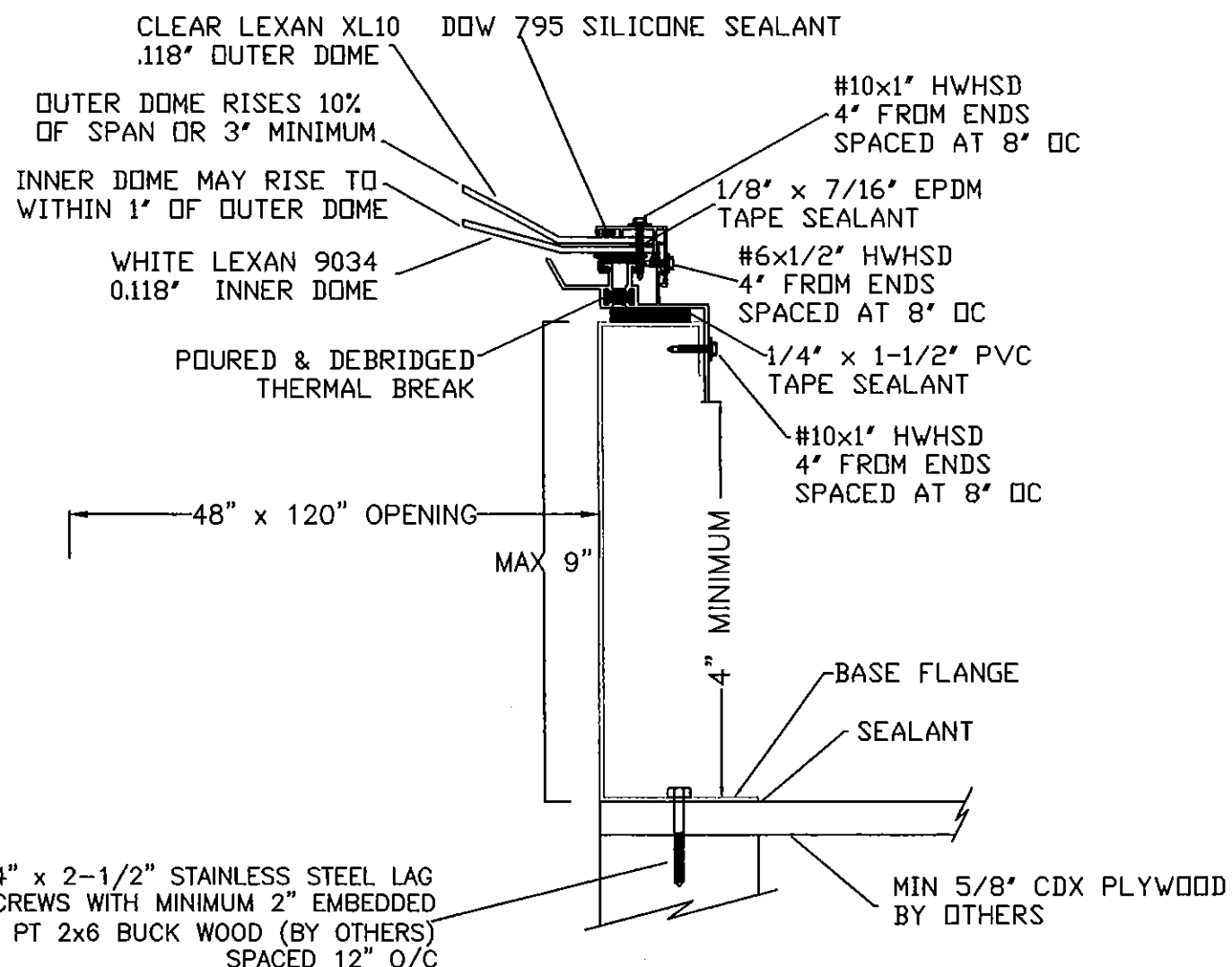
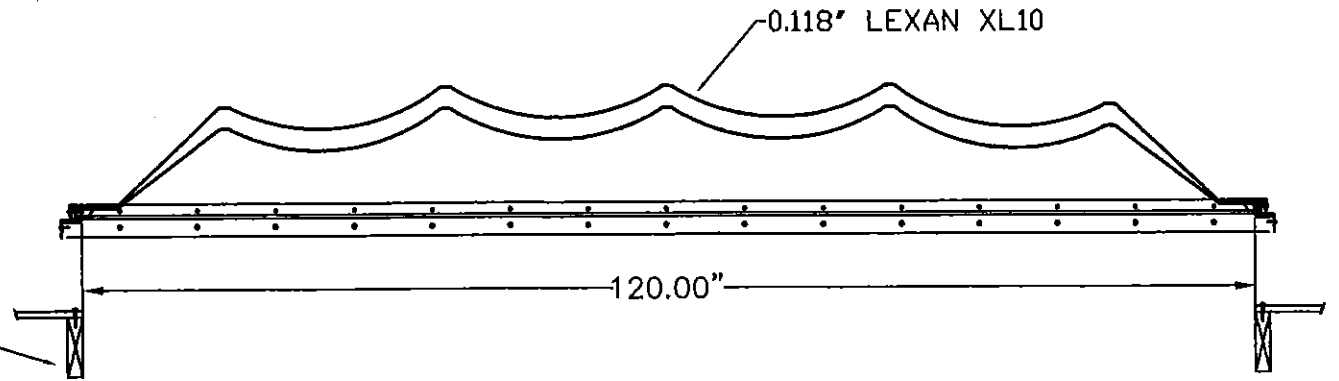
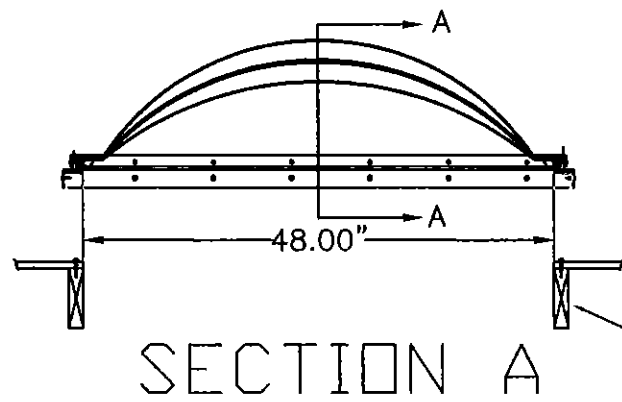

R&S MANUFACTURING AND SALES CO.
 3575 Old Conejo Rd.
 Newbury Park, CA
 (805)375-3980
 fax 375-3981

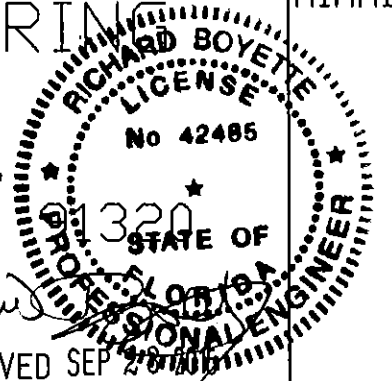

MIAMI-DADE PER:
 Approved as complying with the Florida Building Code
 Date 10/22/2015
 NOAH 14-0505.09
 Miami Dade Product Control
 By *[Signature]*

RICHARD BOYETTE
 FL PE #42485
 RICHARD BOYETTE CONSULTING, INC.
 COA #9707
 4031 COCONUT BLVD
 ROYAL PALM BEACH
 FL 33411
 561-790-5766

PRODUCT: HURRICANE RATED MODEL RS SKYLIGHT	
DATE 9/23/15	SHEET: 2 OF 4
SCALE NTS	DRAWING # SK-7792-2

METAL BUILDING FLASHING 8" HIGH INSULATED

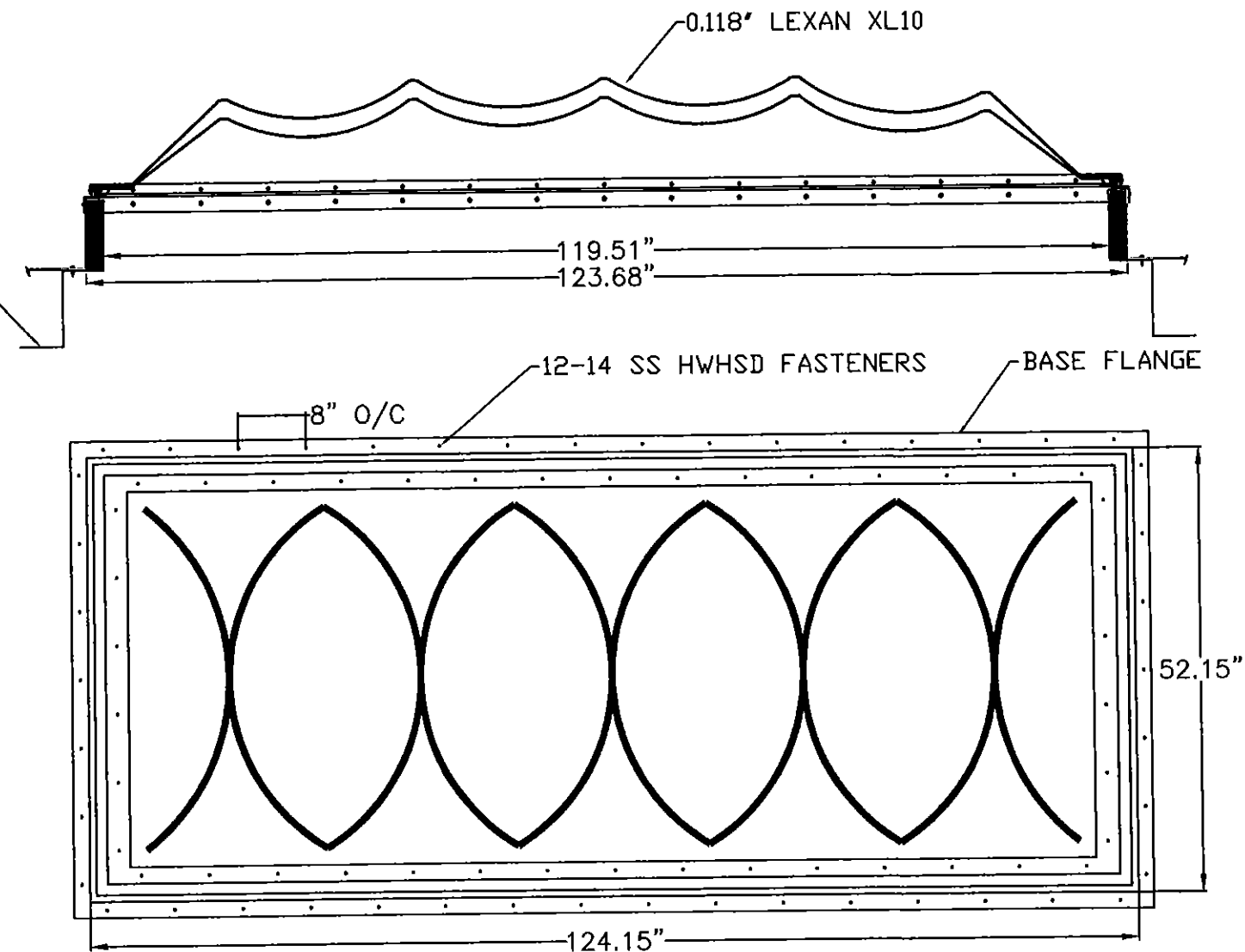
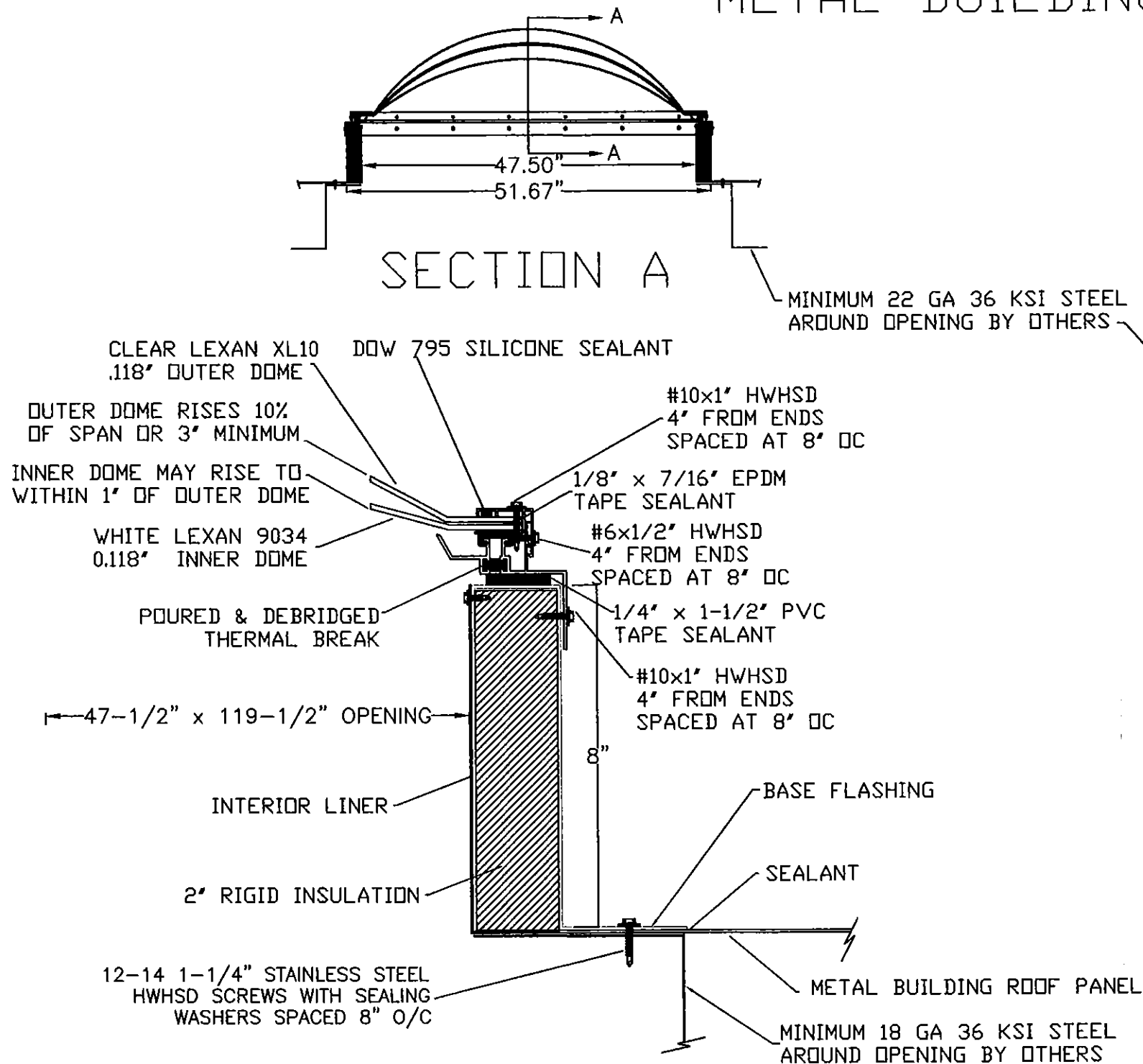

R&S MANUFACTURING AND SALES CO.
3575 Old Conejo Rd.
Newbury Park, CA
(805)375-3980
fax 375-3981

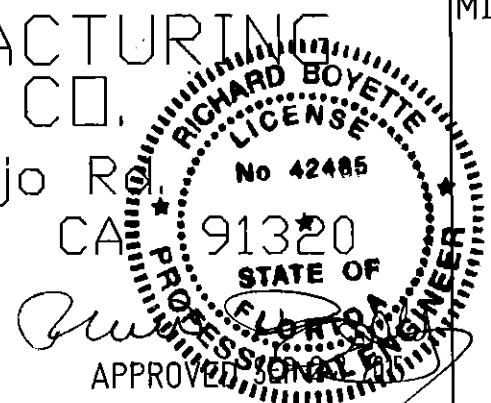

MIAMI-DADE PER:

Approved as complying with the Florida Building Code
Date 10/22/2015
NOA# 14-0505-09
Miami Dade Product Control
By *He G. Allen*

RICHARD BOYETTE
FL PE #42485
RICHARD BOYETTE CONSULTING, INC.
COA #9707
4031 COCONUT BLVD
ROYAL PALM BEACH
FL 33411
561-790-5766

PRODUCT: HURRICANE RATED MODEL RS SKYLIGHT	
DATE 9/23/15	SHEET: 3 OF 4
SCALE NTS	DRAWING # SK-7792-3

WOOD CURB MOUNT

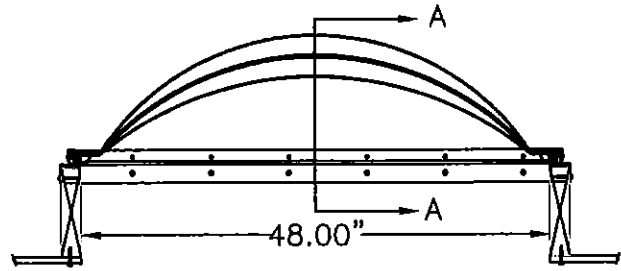

SECTION A

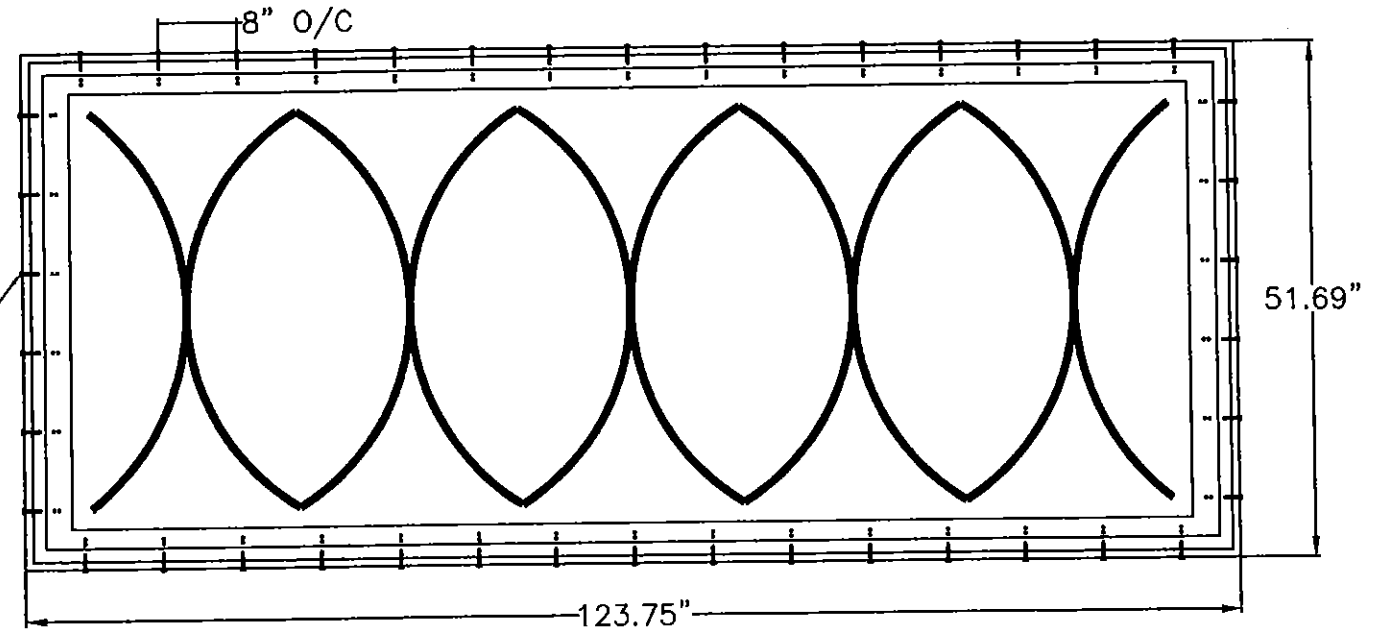
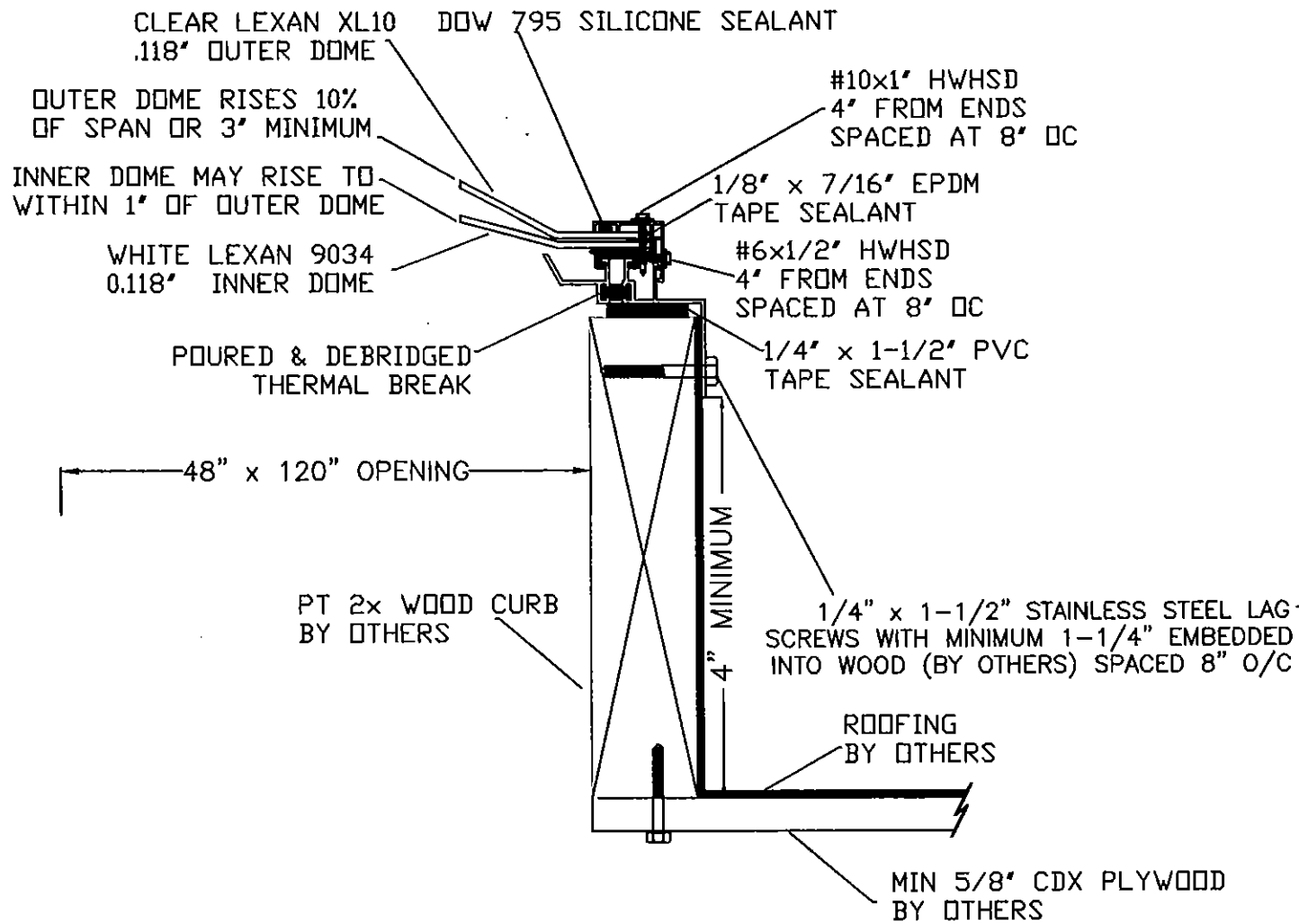
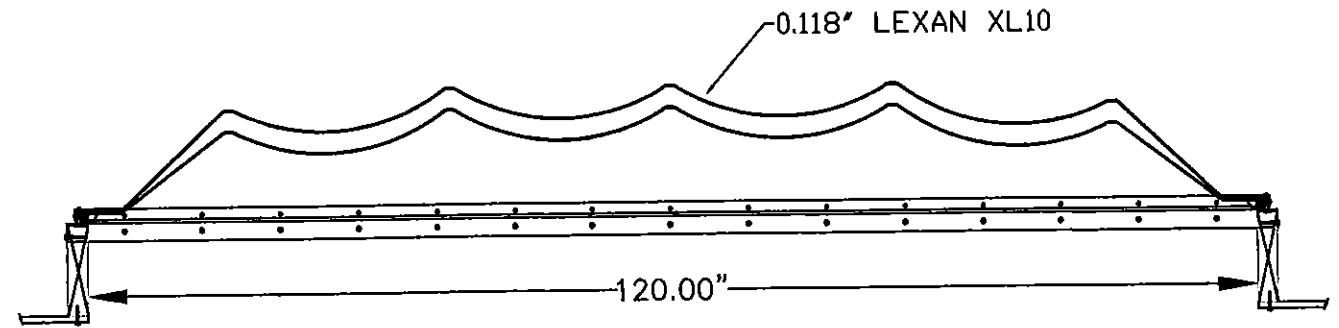

R&S MANUFACTURING
AND SALES CO.
3575 Old Conejo Rd
Newbury Park, CA
(805)375-3980
fax 375-3981

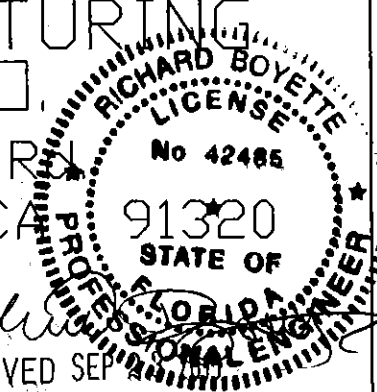

MIAMI-DADE PER:

Approved as complying with the
Florida Building Code
Date 10/22/2015
NOA# 14-0505.09
Miami Dade Product Control

By *Richard Boyette*

RICHARD BOYETTE
FL PE #42485
RICHARD BOYETTE
CONSULTING, INC.
COA #9707
4031 COCONUT BLVD
ROYAL PALM BEACH
FL 33411
561-790-5766

PRODUCT:
HURRICANE RATED MODEL RS SKYLIGHT

DATE
9/23/15

SHEET:
4 OF 4

SCALE
NTS

DRAWING #
SK-7792-4

APPROVED SEP 23 2015