



DEPARTMENT OF REGULATORY AND ECONOMIC RESOURCES (RER)
BOARD AND CODE ADMINISTRATION DIVISION

MIAMI-DADE COUNTY
PRODUCT CONTROL SECTION
11805 SW 26 Street, Room 208
Miami, Florida 33175-2474
T (786) 315-2590 F (786) 315-2599
www.miamidade.gov/economy

NOTICE OF ACCEPTANCE (NOA)

Polyglass USA Inc.
150 Lyon Drive
Fernley, NV 89408

SCOPE:

This NOA is being issued under the applicable rules and regulations governing the use of construction materials. The documentation submitted has been reviewed and accepted by Miami-Dade County RER - Product Control Section to be used in Miami Dade County and other areas where allowed by the Authority Having Jurisdiction (AHJ).

This NOA shall not be valid after the expiration date stated below. The Miami-Dade County Product Control Section (In Miami Dade County) and/or the AHJ (in areas other than Miami Dade County) reserve the right to have this product or material tested for quality assurance purposes. If this product or material fails to perform in the accepted manner, the manufacturer will incur the expense of such testing and the AHJ may immediately revoke, modify, or suspend the use of such product or material within their jurisdiction. RER reserves the right to revoke this acceptance, if it is determined by Miami-Dade County Product Control Section that this product or material fails to meet the requirements of the applicable building code.

This product is approved as described herein, and has been designed to comply with the Florida Building Code including the High Velocity Hurricane Zone of the Florida Building Code.

DESCRIPTION: Polyglass Polystick Underlayments

LABELING: Each unit shall bear a permanent label with the manufacturer's name or logo, city, state and following statement: "Miami-Dade County Product Control Approved", unless otherwise noted herein.

RENEWAL of this NOA shall be considered after a renewal application has been filed and there has been no change in the applicable building code negatively affecting the performance of this product.

TERMINATION of this NOA will occur after the expiration date or if there has been a revision or change in the materials, use, and/or manufacture of the product or process. Misuse of this NOA as an endorsement of any product, for sales, advertising or any other purposes shall automatically terminate this NOA. Failure to comply with any section of this NOA shall be cause for termination and removal of NOA.

ADVERTISEMENT: The NOA number preceded by the words Miami-Dade County, Florida, and followed by the expiration date may be displayed in advertising literature. If any portion of the NOA is displayed, then it shall be done in its entirety.

INSPECTION: A copy of this entire NOA shall be provided to the user by the manufacturer or its distributors and shall be available for inspection at the job site at the request of the Building Official.

This revises NOA #12-0713.02 and consists of pages 1 through 9.
The submitted documentation was reviewed by Alex Tigera.



NOA No.: 14-0717.08
Expiration Date: 09/13/16
Approval Date: 01/22/15
Page 1 of 9

ROOFING COMPONENT APPROVAL

Category: Roofing
Sub-Category: Underlayment
Material: SBS , APP Self-Adhering Modified Bitumen

PRODUCTS DESCRIPTION:

<u>Product</u>	<u>Dimensions</u>	<u>Test Specification</u>	<u>Product Description</u>
Polystick MTS <i>Manufacturing Location #2</i>	Roll: 65'8" x 3'3- ³ / ₈ " 60 mils thick	TAS 103	A homogeneous, rubberized asphalt waterproofing membrane, glass fiber reinforced with polyolefinic film on the upper surface for use as an underlayment for metal roofing, roof tile, slate tiles and shingle underlayment.
Polystick MTS Plus <i>Manufacturing Location #2</i>	Roll: 65'8" x 3'3- ³ / ₈ " 60 mils thick	TAS 103	A homogeneous, rubberized asphalt waterproofing membrane, glass fiber reinforced with polyolefinic film on the upper surface for use as an underlayment for metal roofing, roof tile, slate tiles and shingle underlayment.
Polystick IR-Xe <i>Manufacturing Location #1 & #2</i>	Roll: 65' x 3'3- ³ / ₈ " Or 65' x 3' 60 mils thick	ASTM D 1970	A fine granular/sand top surface self-adhering, APP polymer modified, fiberglass reinforced, bituminous sheet material for use as an underlayment in sloped roof assemblies. Designed as an ice & rain shield.
Polystick TU Plus (Surface Printing) <i>Manufacturing Location #1 & #2</i>	Roll: 65' x 3'3- ³ / ₈ " 80 mils thick	TAS 103 and ASTM D 1970	A rubberized asphalt self-adhering, glass-fiber/polyester reinforced waterproofing membrane. Designed as a metal roofing and roof tile underlayment.
Polystick TU P <i>Manufacturing Location #2</i>	Roll: 32'10" x 3'3- ³ / ₈ " 130 mils thick	TAS 103 and ASTM D 1970	A rubberized asphalt waterproofing membrane, glass-fiber/polyester reinforced, with a granular surface designed for use as a tile roof underlayment.
Polystick Tile Pro <i>Manufacturing Location #2</i>	Roll: 61' x 3'3- ³ / ₈ " 60 mils thick	TAS 103 and ASTM D 1970	A rubberized asphalt self-adhering, glass-fiber/polyester reinforced waterproofing membrane. Designed as a metal roofing and roof tile underlayment.
Polystick Dual Pro <i>Manufacturing Location #2</i>	Roll: 61' x 3'3- ³ / ₈ " 60 mils thick	TAS 103 and ASTM D 1970	A rubberized asphalt self-adhering, glass-fiber/polyester reinforced waterproofing membrane. Designed as a metal roofing and roof tile underlayment.



PRODUCTS DESCRIPTION:

<u>Product</u>	<u>Dimensions</u>	<u>Test Specification</u>	<u>Product Description</u>
Polystick TU Max <i>Manufacturing Location #2</i>	Roll: 65'8" x 3'3-3/8" 60 mils thick	TAS 103 and ASTM D 1970	A rubberized asphalt self-adhering, polyester reinforced waterproofing membrane. Designed as a roof tile underlayment.
Elastoflex S6 G	Roll: 32' 10" x 3' 3-3/8"	TAS 103 and ASTM D6164	Polyester reinforced, SBS modified bitumen membrane with a burn off polyethylene or sanded back face and a granule top surface. For use in roof tile underlayment systems.

MANUFACTURING PLANTS:

1. Hazelton, PA
2. Winter Haven, FL

EVIDENCE SUBMITTED:

<u>Test Agency</u>	<u>Test Identifier</u>	<u>Test Name/Report</u>	<u>Date</u>
Trinity ERD	P10870.09.08-R1	TAS 103	12/04/08
	P10870.04.09	TAS 103/ASTM D4798 & G155	04/13/09
	P33360.06.10	ASTM D1970	07/01/10
	P33370.03.11	TAS 103	03/02/11
	P33370.04.11	ASTM D 1623	04/26/11
	P36900.09.11	TAS 103/ASTM D4798 & G155	09/01/11
	P37300.10.11	TAS 110/ASTM D4798 & D1970	10/19/11
	P40390.08.12-1	TAS 103 & TAS 110	08/06/12
	P40390.08.12-2	ASTM D 1623	08/07/12
	P40390.10.12	ASTM D 1970	10/03/12
	P37590.07.13-1	ASTM D6164	07/02/13
	P45270.05.14	TAS 103, TAS 110 & ASTM D1623	05/12/14
	P46520.10.14	ASTM D1623	10/03/14
	P44360.10.14	TAS 103 & TAS 110	10/07/14
	P43290.10.14	ASTM D 1970 & TAS 110	10/17/14
	PRI Asphalt Technologies	PUSA-035-02-01	TAS 103
PUSA-055-02-02		TAS 103	12/10/07
PUSA-089-02-01		TAS 103/ASTM D4798 & G155	07/06/09
Momentum Technologies, Inc.	JX20H7A	TAS 103/ASTM D4798 & G155	04/01/08
	RX14E8A	TAS 103/ASTM D4798 & G155	11/09/09
	DX23D8B	TAS 103/ASTM D4798 & G155	02/18/10
	DX23D8A	TAS 103/ASTM D4798 & G155	02/18/10



INSTALLATION PROCEDURES:

Deck Type 1:	Wood, non-insulated
Deck Description:	Min. 19/32” plywood or wood plank
System Type E(1)	Anchor sheet mechanically fastened to deck, membrane adhered
Anchor/Base Sheet:	One or more plies of ASTM D 226 Type II or ASTM D 2626.
Fastening:	Per FBC 1518.2 & 1518.4 Nails and tin caps 12" grid, 6" o.c. at a minimum 4” head lap. (for base sheet only)
Membrane:	Polystick membranes self-adhered.
Surfacing:	See General Limitations Below.
Deck Type 1:	Wood, non-insulated
Deck Description:	Min. 19/32” plywood or wood plank
System Type E(2)	Anchor sheet mechanically fastened to deck, membrane adhered
Anchor/Base Sheet:	One or more plies of ASTM D 226 Type II or ASTM D 2626.
Fastening:	Per FBC 1518.2 & 1518.4 Nails and tin caps 12" grid, 6" o.c. at a minimum 4” head lap. (for base sheet only)
Membrane:	Elastoflex S6 G, hot asphalt applied.
Surfacing:	See General Limitations Below.
Deck Type 1:	Wood, non-insulated
Deck Description:	Min. 19/32” plywood or wood plank
System Type E(3)	Base sheet mechanically fastened deck, subsequent cap membrane self- adhered.
Anchor/Base Sheet:	One or more plies of ASTM D 226 Type II or ASTM D 2626.
Fastening:	Per FBC 1518.2 & 1518.4 Nails and tin caps 12" grid, 6" o.c. at a minimum 4” head lap. (for base sheet only)
Ply Sheet: (Optional)	Polystick MTS Plus, self-adhered with minimum 3” horizontal laps and minimum 6” vertical laps.
Membrane:	Polystick TU Plus, self-adhered.
Surfacing:	See General Limitations Below.

INSTALLATION REQUIREMENTS:

1. All nails in the deck shall be carefully checked for protruding heads. Re-fasten any loose decking panels, and sweep the deck thoroughly to remove any dust and debris prior to application.
2. Place the underlayment over metal drip edge in accordance with RAS 111.
3. Place the first course of membrane parallel to the eave, rolling the membrane to obtain maximum contact. Remove the release film as the membrane is applied. All side laps shall be a minimum of 3-½" and end laps shall be a minimum of 6". Roll the membrane into place after removing the release strip. Vertical strapping of the roof with Polystick is acceptable. Membrane shall be back nailed in accordance with applicable building code.
4. When applying the membrane in the valley, start at the low point and work to the high point, rolling the membrane from the center outward in both directions.
5. For ridge applications, center the membrane and roll from the center outward in both directions.
6. Roll or broom the entire membrane surface so as to have full contact with the surface, giving special attention to lap areas.
7. Flash vent pipes, stacks, chimneys and penetrations in compliance with Roof Assembly current Product Control Notice of Acceptance.
8. All protrusions or drains shall be initially taped with a 6" piece of underlayment. The flashing tape shall be pressed in place and formed around the protrusion to ensure a tight fit. A second layer of Polystick shall be applied over the underlayment.

GENERAL LIMITATIONS:

1. Fire classification is not part of this acceptance.
2. Polystick MTS, Polystick MTS Plus, Polystick TU Plus, Polystick Tile Pro and Polystick Dual Pro may be used in asphaltic shingles, wood shakes and shingles, non-structural metal roofing, roof tile systems and quarry slate roof assemblies. Polystick TU P may be used in all the previous assemblies listed except metal roofing. Polystick IR-Xe may be used in all the previous assemblies listed except metal roofing and roof tile systems. Polystick TU Max may be used in non-structural metal roofing and roof tile systems. Elastoflex S6 G may be used in roof tile systems only.
3. Deck requirements shall be in compliance with applicable building code.
4. Polyglass Polystick membranes shall be applied to a smooth, clean and dry surface. The deck shall be free of irregularities.
5. Polyglass Polystick membranes and underlayments shall not be adhered directly over a pre-existing roof membrane as a recover system.
6. Polyglass Polystick membranes shall not be left exposed as a temporary roof for longer than the amount of days listed in the table below after application. Polyglass reserves the right to revise or alter product exposure times; not to exceed the preceding maximum time limitations.

Exposure Limitations (days)									
	MTS	IR-Xe	Elastoflex S6 G	TU Plus	TU P	Tile Pro	Dual Pro	TU Max	MTS Plus
Winter Haven, FL.	180	90	180	180	180	180	180	90	180
Hazelton, PA.	N/A	90	N/A	180	N/A	N/A	N/A	N/A	N/A

7. All products listed herein shall have a quality assurance audit in accordance with the Florida Building Code and Rule 9N-3 of the Florida Administrative Code.



8. In roof tile application, data for the attachment resistance of roof tiles shall be as set forth in the roof tile manufacturer's Notice of Acceptance. Polystick TU Plus, Polystick Tile Pro, Polystick TU Max or Elastoflex S6 G may be used in both adhesive set and mechanically fastened roof tile applications. Polystick Dual Pro is limited to mechanically fastened roof tile applications. Polystick MTS and Polystick MTS Plus are limited to mechanically fastened with the limitations outlined in Section 9. Polystick TU P may be used in mechanically fastened roof tile applications with the exception of mortar set tile applications.
- 9a. The maximum roof slope for use as roof tile underlayment for (direct-to-deck) tile assemblies shall be as follows: (See Table Below)

Tile Profile	Polystick MTS	Elastoflex S6 G	Polystick TU Plus, TU P, Tile Pro, Dual Pro	Polystick TU Max	Polystick MTS Plus ¹
Flat Tile	Prohibited without battens	4:12	No limitation	No limitation	5:12
Profiled Tile	Prohibited without battens	4:12	No limitation	No limitation	4:12

The above slope limitations can be exceeded only by using battens and counter battens in accordance with the Approved Tile System Notice of Acceptance and applicable Florida Building Code requirements. **Battens are required for both loading and installation of tiles at all times.**

¹The following limitations shall be apply when using Polystick MTS Plus:

- Slopes up to those shown in the table above will require staggering of tiles – two tiles laid perpendicular to slope followed by a maximum four tile stack parallel to the slope, for a total of 6 tiles. (See Figure 1 below)
- Battens shall be used for staggering of lugged tiles above 4:12
- Battens shall be used for staggering of flat tiles above 5:12

↓ Slope



Figure 1: Staggering Method

- 9b. There shall be no roof slope limitation for the Polystick MTS Plus / Polystick TU Plus two-ply underlayment system when a applied using the staggering method outlined above.

10. Care should be taken during the loading procedure to keep foot traffic to a minimum and to avoid dropping of tile directly on the underlayment. Refer to Polyglass' Tile loading detail below for loading procedure for all underlayments except Polystick MTS which shall be loaded onto battens.

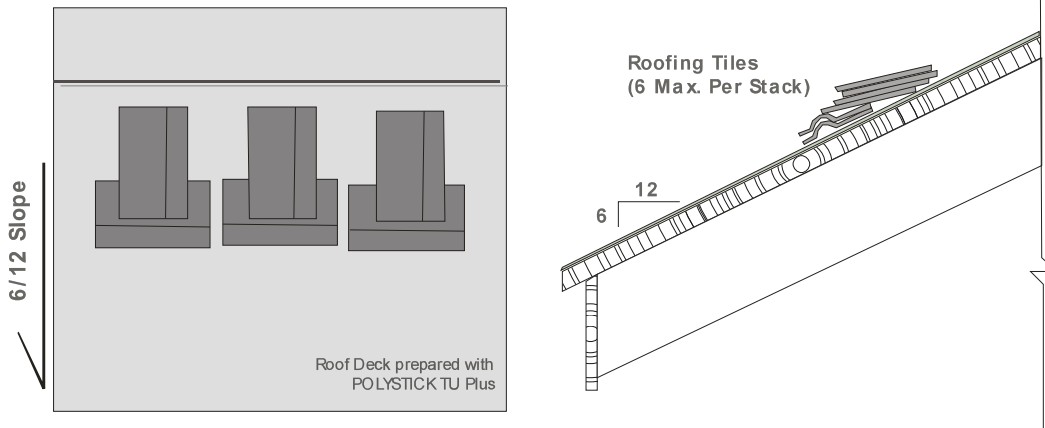

11. Refer to prepared roofing system Product Control Notice of Acceptance for listed approval of this product with specific prepared roofing products. Polystick MTS, Polystick MTS Plus, Polystick IR-Xe, Polystick TU Plus, Polystick TU P, Polystick TU Max, Polystick Dual Pro, Polystick Tile Pro or Elastoflex S6 G may be used with any approved roof covering Notice of Acceptance listing Polystick MTS, Polystick MTS Plus, Polystick IR-Xe, Polystick TU Plus, Polystick TU P, Polystick TU Max, Polystick Dual Pro, Polystick Tile Pro or Elastoflex S6 G as a component part of an assembly in the Notice of Acceptance. If Polystick MTS, Polystick MTS Plus, Polystick IR-Xe, Polystick TU Plus, Polystick TU P, Polystick TU Max, Polystick Dual Pro, Polystick Tile Pro or Elastoflex S6 G are not listed, a request may be made to the Authority Having Jurisdiction (AHJ) or the Miami-Dade County Product Control Department for approval provided that appropriate documentation is provided to detail compatibility of the products, wind uplift resistance, and fire testing results.

LABELING:

1. All membranes or packaging shall bear the imprint or identifiable marking of the manufacturer's name or logo, city and state of manufacturing facility and the following statement: "Miami-Dade County Product Control Approved" or the Miami-Dade County Product Control Seal as shown below.



BUILDING PERMIT REQUIREMENTS:

Application for building permit shall be accompanied by copies of the following:

1. This Notice of Acceptance.
2. Any other documents required by the Building Official or applicable building code in order to properly evaluate the installation of this materials.



POLYGLASS GENERAL APPLICATION GUIDELINES FOR POLYSTICK MEMBRANES:

1. Polyglass does accept the direct application of Polystick underlayment membranes to wood decks. Installers are cautioned to refer to applicable local building codes prior to direct deck installation to ensure this is acceptable. Please also refer to applicable Product Data Sheets of the corresponding products.
2. All rolls, with the exception of Polystick TU Plus should be back-nailed in selvage edge seam as per Polyglass Back Nailing Guide. Nails shall be, 11 gauge ring shank type, applied with a minimum 1” metal disk as required in Dade County or simplex type nail as otherwise allowable in other regions, at a minimum rate of 12” o.c. Polystick TU Plus should be back nailed in designated area marked “nail area, area para clavar” on the face of membrane, with the above stated nails and/or disks. The head lap membrane is to cover the area being back-nailed. (Please refer to applicable local building codes prior to installation.)
3. All seal lap seams (selvage laps) must be rolled with a hand roller to ensure full contact.
4. All fabric over fabric; and granule over granule end laps, shall have a 6” wide, uniform layer of Polyglass Polyplus 55 Premium Modified Flashing Cement, Polyglass Polyplus 50 Premium MB Flashing Cement, XtraFlex 50 Premium Modified Wet/Dry Cement, Polyglass PG500 MB Flashing Cement, applied in between the application of the lap. The use of mastic between the laps does not apply to Polystick MTS.
5. A maximum of 6 tiles per stack are allowed when loading tile on the underlayments. Refer to the Polyglass Tile Loading Guidelines. See General Limitations #9 and #10.
6. Battens and/or Counter-battens, as required by the tile manufacturers NOA’s, must be used on all projects for pitch/slopes of 7”/12” or greater. It is suggested that on pitch/slopes in excess of 6 ¼”/12”, precautions should be taken, such as the use of battens to prevent tile sliding during the loading process.
7. Minimum cure time after membrane installation & before loading of roofing tiles is Forty-Eight (48) Hours.
8. Polystick membranes may not be used in any exposed application such as crickets, exposed valleys, or exposed roof to wall details.
9. Repair of Polystick membranes is to be accomplished by applying Polyglass Polyplus 55 Premium Modified Flashing Cement, Polyglass Polyplus 50 Premium MB Flashing Cement, XtraFlex 50 Premium Modified Wet/Dry Cement, Polyglass PG500 MB Flashing Cement to the area in need of repair, followed by a patch of the Polystick material of like kind should be set and hand rolled in place over the area needing such repair. Patching membrane shall be a minimum of 6 inches in either direction. The repair should be installed in such a way so that water will run parallel to or over the top of all laps of the patch.
10. All self-adhered membranes must be rolled to ensure full contact with approved substrates. Polyglass requires a minimum of 40 lbs for a weighted roller for the rolling of the field membrane. Hand rollers are acceptable for rolling of patches or small areas of the roof. Brooming may be used where slope prohibits rolling.
11. All approved substrates should be dry, clean and properly prepared, before any application of Polystick membranes commences. An approved substrate technical bulletin can be furnished upon request. It is recommended to refer to applicable building codes prior to installation to verify acceptable substrates.
12. The Polyglass Miami-Dade Notice of Acceptance (NOA) approval for Polystick membranes can be furnished upon request by our Technical Services Department by calling 1 (800) 894-4563.

13. Questions in regards to the application of Polyglass products should be directed to our Technical Services Department at 1 (800) 894-4563.
14. Polyglass recommends that applicators follow good roofing practices and applicable procedures as outlined by the National Roofing Contractors Association (NRCA).

PLEASE CHECK WITH LOCAL BUILDING CODES REGARDING LIMITATIONS OF SPECIFIC APPLICATIONS. LOCAL CODES MAY SUPERSEDE POLYGLASS REQUIREMENTS AND RECOMMENDATIONS.

END OF THIS ACCEPTANCE

