



DEPARTMENT OF REGULATORY AND ECONOMIC RESOURCES (RER)
BOARD AND CODE ADMINISTRATION DIVISION
NOTICE OF ACCEPTANCE (NOA)

MIAMI-DADE COUNTY
PRODUCT CONTROL SECTION
11805 SW 26 Street, Room 208
Miami, Florida 33175-2474
T (786) 315-2590 F (786) 315-2599
www.miamidade.gov/economy

J.B. Garage Doors, Inc.
12195 NW 98th Avenue
Hialeah Gardens, FL 33018

SCOPE:

This NOA is being issued under the applicable rules and regulations governing the use of construction materials. The documentation submitted has been reviewed and accepted by Miami-Dade County RER-Product Control Section to be used in Miami Dade County and other areas where allowed by the Authority Having Jurisdiction (AHJ). This NOA shall not be valid after the expiration date stated below. The Miami-Dade County Product Control Section (In Miami Dade County) and/or the AHJ (in areas other than Miami Dade County) reserve the right to have this product or material tested for quality assurance purposes. If this product or material fails to perform in the accepted manner, the manufacturer will incur the expense of such testing and the AHJ may immediately revoke, modify, or suspend the use of such product or material within their jurisdiction. RER reserves the right to revoke this acceptance, if it is determined by Miami-Dade County Product Control Section that this product or material fails to meet the requirements of the applicable building code. This product is approved as described herein, and has been designed to comply with the Florida Building Code, including the High Velocity Hurricane Zone.

DESCRIPTION: Models 724/720 Steel Sectional Garage Door up to 10'-4" Wide x 22' High (DP +101.0, -116.0 PSF)

APPROVAL DOCUMENT: Drawing No. 08-04, titled "Steel Overhead Garage Door", dated 04/03/2008, with revision C dated 09/22/2014, sheets 1 through 4 of 4, prepared by Al-Farooq Corporation, signed and sealed by Javad Ahmad, P.E., bearing the Miami-Dade County Product Control revision stamp with the Notice of Acceptance number and expiration date by the Miami-Dade County Product Control Section.

MISSILE IMPACT RATING: Large and Small Missile Impact Resistant

LABELING: A permanent label with the manufacturer's name or logo, manufacturing address, model number, the positive and negative design pressure rating, indicate impact rated if applicable, installation instruction drawing reference number, approval number (NOA), the applicable test standards, and the statement reading 'Miami-Dade County Product Control Approved' is to be located on the door's side track, bottom angle, or inner surface of a panel.

LIMITATION: This door has not been tested for air infiltration.

RENEWAL of this NOA shall be considered after a renewal application has been filed and there has been no change in the applicable building code negatively affecting the performance of this product.

TERMINATION of this NOA will occur after the expiration date or if there has been a revision or change in the materials, use, and/or manufacture of the product or process. Misuse of this NOA as an endorsement of any product, for sales, advertising or any other purposes shall automatically terminate this NOA. Failure to comply with any section of this NOA shall be cause for termination and removal of NOA.

ADVERTISEMENT: The NOA number preceded by the words Miami-Dade County, Florida, and followed by the expiration date may be displayed in advertising literature. If any portion of the NOA is displayed, then it shall be done in its entirety.

INSPECTION: A copy of this entire NOA shall be provided to the user by the manufacturer or its distributors and shall be available for inspection at the job site at the request of the Building Official.

This NOA revises NOA # 13-1126.18 and consists of this page 1 and evidence pages E-1 and E-2, as well as approval document mentioned above.

The submitted documentation was reviewed by Carlos M. Utrera, P.E.



[Signature]
12/17/2014

NOA No. 14-1014.11
Expiration Date: February 4, 2019
Approval Date: December 24, 2014
Page 1

NOTICE OF ACCEPTANCE: EVIDENCE SUBMITTED

A. DRAWINGS

1. Drawing No. **08-04**, titled "Steel Overhead Garage Door", dated 04/03/2008, with revision C dated 09/22/2014, sheets 1 through 4 of 4, prepared by Al-Farooq Corporation, signed and sealed by Javad Ahmad, P.E.

B. TESTS "Submitted under NOA # 08-1107.02"

1. Test reports on 1) Uniform Static Air Pressure Test, Loading per FBC TAS 202-94
2) Forced Entry Test, per FBC 2411 3.2.1, TAS 202-94
along with marked-up drawings and installation diagram of a Series 724 24 GA Steel Sectional Commercial Garage Door, prepared by Hurricane Engineering & Testing, Inc, Test Reports No. **HETI-08-2132A**, dated 05/28/2008, signed and sealed by Candido F. Font, P.E.
2. Test reports on 1) Large Missile Impact Test per FBC, TAS 201-94
2) Cyclic Wind Pressure Loading per FBC, TAS 203-94
along with marked-up drawings and installation diagram of Series 724 24 GA Steel Sectional Commercial Garage Doors, prepared by Hurricane Engineering & Testing, Inc, Test Reports No. **HETI-08-2132B**, dated 05/28/2008, signed and sealed by Candido F. Font, P.E.
3. Test report on Tensile Test per ASTM E 8 of the above sectional garage door's skin, prepared by Hurricane Engineering & Testing, Inc, Test Report No. **HETI-08-T127**, dated 05/28/2008, signed and sealed by Candido F. Font, P.E.

"Submitted under NOA # 99-1203.01"

4. Test report on Salt Spray (Corrosion) Test per ASTM B 117 of a painted G-40 steel panels, prepared by Celotex Corporation, Test Report No. **258592**, dated 08/17/1998, signed by W. A. Jackson, P.E.

C. CALCULATIONS

1. Anchor verification calculations prepared by Al-Farooq Corporation, dated 09/19/2014, signed and sealed by Javad Ahmad, P.E.



12/17/2014

Carlos M. Utrera, P.E.
Product Control Examiner
NOA No. 14-1014.11
Expiration Date: February 4, 2019
Approval Date: December 24, 2014

NOTICE OF ACCEPTANCE: EVIDENCE SUBMITTED

C. CALCULATIONS (Cont.) *"Submitted under NOA # 08-1107.02"*

2. Anchor verification calculations and structural analysis prepared by Al-Farooq Corporation, complying with F.B.C 2004/2007, dated 08/06/2008, signed and sealed by Humayoun Farooq, P.E.

D. QUALITY ASSURANCE

1. Miami-Dade Department of Regulatory and Economic Resources (RER)

E. MATERIAL CERTIFICATIONS

1. Notice of Acceptance No. **14-0311.08**, issued to Insulfoam, LLC, for their Insulfoam Expanded Polystyrene Insulation, approved on 08/14/2014 and expiring on 11/29/2017.
2. Notice of Acceptance No. **11-0926.07**, issued to Dyplast Products, LLC, for their Expanded Polystyrene Block Type Insulation, approved on 11/10/2011 and expiring on 01/11/2017.
3. Notice of Acceptance No. **11-0926.06**, issued to Dyplast Products, LLC, for their Dyplast ISO-C1 Polyisocyanurate Insulation, approved on 11/10/2011 and expiring on 01/11/2017.
4. Notice of Acceptance No. **10-1129.04**, issued to Cellofoam North America Inc, for their Expanded Polystyrene Block Insulation, approved on 02/24/2011 and expiring on 02/24/2016.

F. STATEMENTS

1. Statement letter of code conformance to 5th edition (2014) FBC and no financial interest issued by Al-Farooq Corporation, dated 09/19/2014, signed and sealed by Javad Ahmad, P.E.

"Submitted under NOA # 13-1126.18"

2. Statement letter of code conformance to 2010 FBC issued by Al-Farooq Corporation, dated 11/05/2013, signed and sealed by Javad Ahmad, P.E.

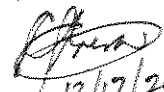

12/17/2014

Carlos M. Utrera, P.E.
Product Control Examiner
NOA No. 14-1014.11

Expiration Date: February 4, 2019
Approval Date: December 24, 2014

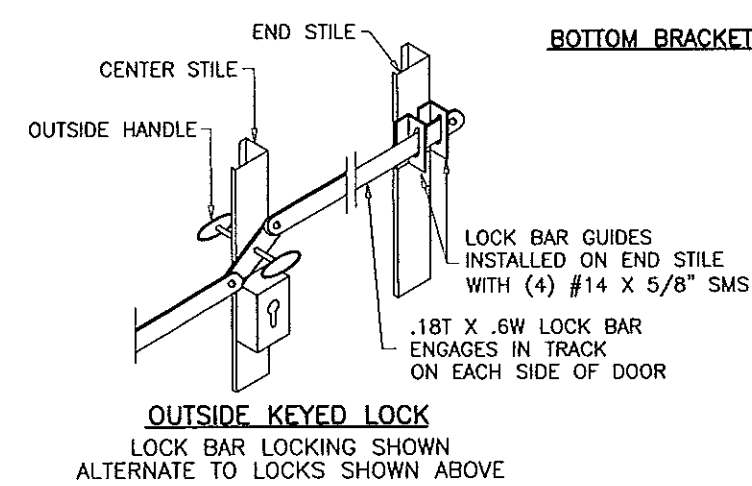
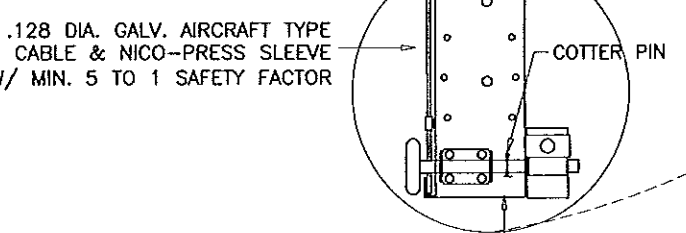
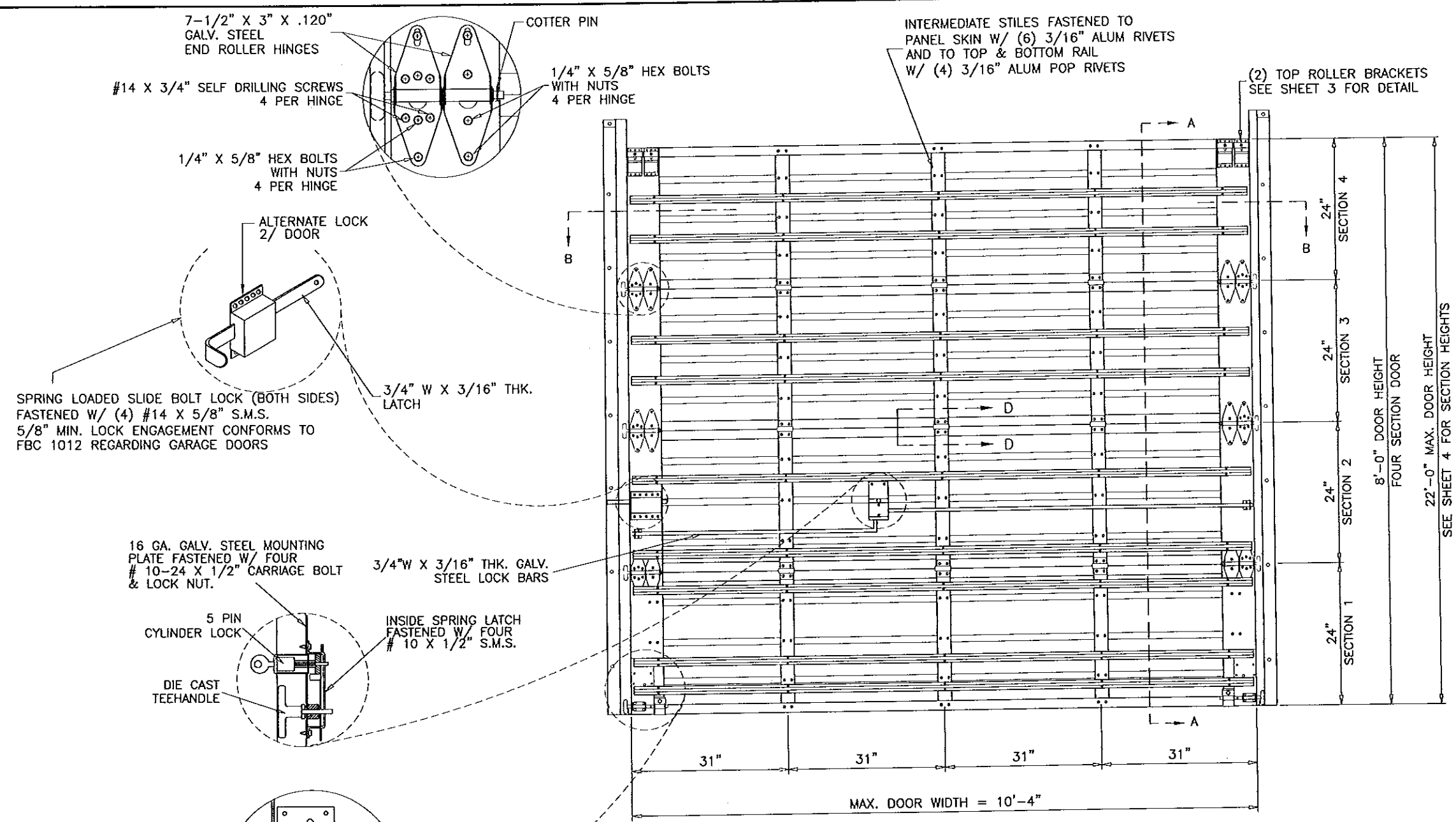

BOTTOM BRACKET
 11" X 4-1/2" X 0.1" STEEL PLATE WITH
 (2) 1/4" X 5/8" HEX BOLTS W/ NUTS
 (5) #14 X 5/8" SMS

THIS PRODUCT IS RATED FOR LARGE MISSILE IMPACT

GENERAL NOTES

1. THIS PRODUCT HAS BEEN DESIGNED AND TESTED TO COMPLY WITH THE REQUIREMENTS OF THE FLORIDA BUILDING CODE (FBC) FIFTH EDITION (2014) INCLUDING HIGH VELOCITY HURRICANE ZONE (HVHZ).
2. ANCHORS SHALL BE AS LISTED, SPACED AS SHOWN ON DETAILS. ANCHOR EMBEDMENT TO BASE MATERIAL SHALL BE BEYOND WALL DRESSING OR STUCCO.
3. ALL BOLTS, NUTS AND WASHERS SHALL BE ZINC PLATED CARBON STEEL.
4. ANCHORING OR LOADING CONDITIONS OTHER THAN THOSE SHOWN IN THESE DETAILS ARE NOT PART OF THIS APPROVAL.

J.B. DOOR MODELS: 10'-4"W X 22'H MAX

MODEL	DESCRIPTION
724	24 GA. ROLL FORMED STEEL DOOR
720	20 GA. ROLL FORMED STEEL DOOR

NOTE: MODEL 724 TESTED.

MAXIMUM DESIGN LOAD RATING = + 101.0 PSF
 (FOR SIZES SHOWN OR SMALLER) - 116.0 PSF

Engr: JAVAD AHMAD
 CIVIL
 FLA. PE # 70592
 C.A.N. 3538

SEP 24 2014

PRODUCT REVISED
 as complying with the Florida
 Building Code
 Acceptance No. 14-104-11
 Expiration Date 02/04/2019

By: *[Signature]*
 Miami Dade Product Control

AL-FAROOQ CORPORATION
 ENGINEERS & PRODUCT DEVELOPMENT
 1235 S.W. 87 AVE
 MIAMI, FLORIDA 33174
 TEL (305) 264-8100 FAX (305) 262-6978
 GARAGE\08-04JB

STEEL OVERHEAD GARAGE DOOR

J.B. GARAGE DOORS INC.
 12195 N.W. 98 TH. AVE.
 HIALEAH GARDENS, FL. 33016
 TEL (305) 558 - 1658

NO	DATE	BY	DESCRIPTION
A	12.09.08		REV. PER BCCO COMMENTS
B	11.21.11		UPDATED TO 2010 FBC
C	09.22.14		UPDATED TO 2014 FBC

Revisions:

date: 04-03-08
 scale: NONE
 dr. by: HAMID
 chk. by:

drawing no.
08-04

sheet 1 of 4

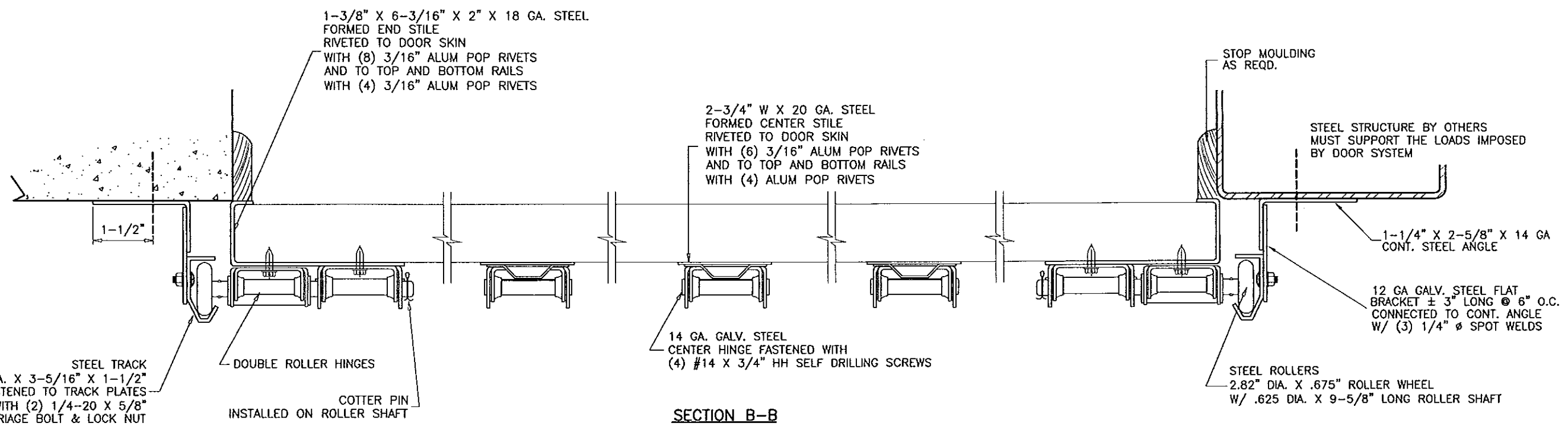

SECTION B-B

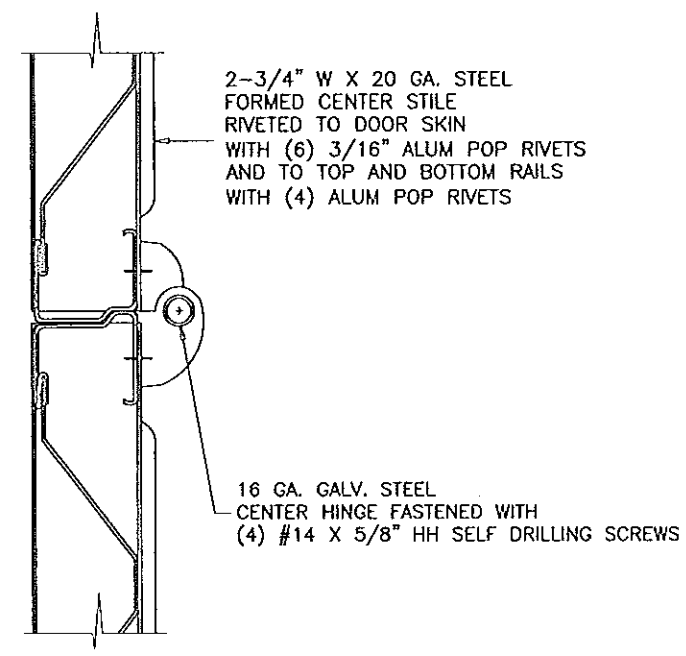

SECTION D-D

afc
AL-FAROOQ CORPORATION
 ENGINEERS & PRODUCT DEVELOPMENT
 1235 S.W. 87 AVE
 MIAMI, FLORIDA 33174
 TEL (305) 264-8100 FAX (305) 262-6978
 GARAGE\08-04.B

STEEL OVERHEAD GARAGE DOOR
J.B. GARAGE DOORS INC.
 12195 N.W. 98 TH. AVE.
 HIALEAH GARDENS, FL. 33016
 TEL. (305) 558 - 1658

Revisions:

NO	DATE	BY	DESCRIPTION
A	12.09.08		REV. PER BCCO COMMENTS
B	11.21.11		NO CHANGE THIS SHEET
C	09.22.14		NO CHANGE THIS SHEET

Engr: JAVAD AHMAD
 CIVIL
 FLA. PE # 70592
 C.A.N. 3538
 SEP 29 2014

PRODUCT REVISED
 as complying with the Florida
 Building Code
 Acceptance No 14-1014-11
 Expiration Date 02/04/2019
 By *[Signature]*
 Miami Dade Product Control

date:	04-03-08
scale:	NONE
dr. by:	HAMID
chk. by:	
drawing no.	08-04
sheet	2 of 4

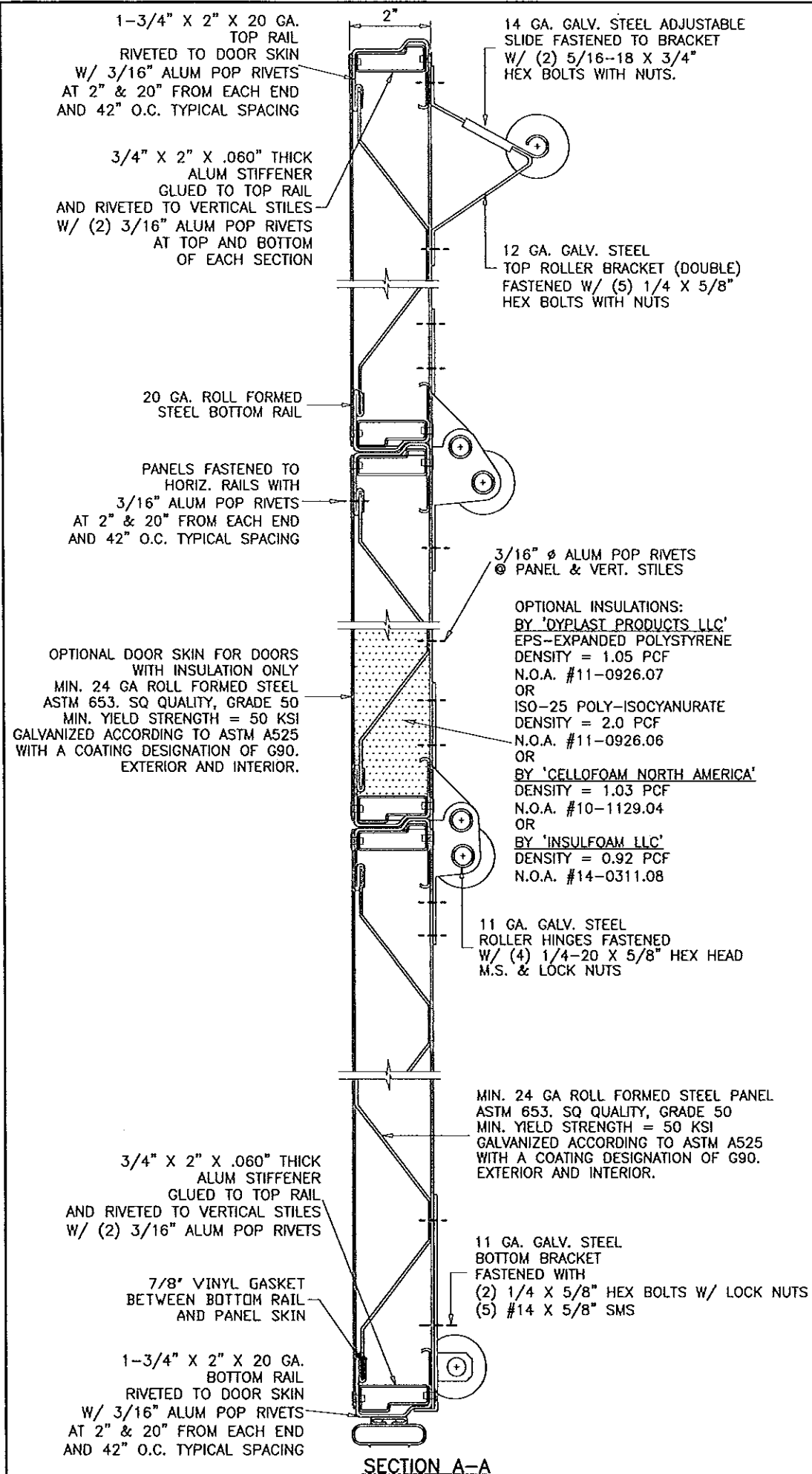

SECTION A-A

SEE SECTIONS AT RIGHT FOR LOCATION OF REINFORCING TRUSSES

TWO (2) REINFORCING TRUSSES PER SECTION EXCEPT THREE (3) ON THE BOTTOM SECTION

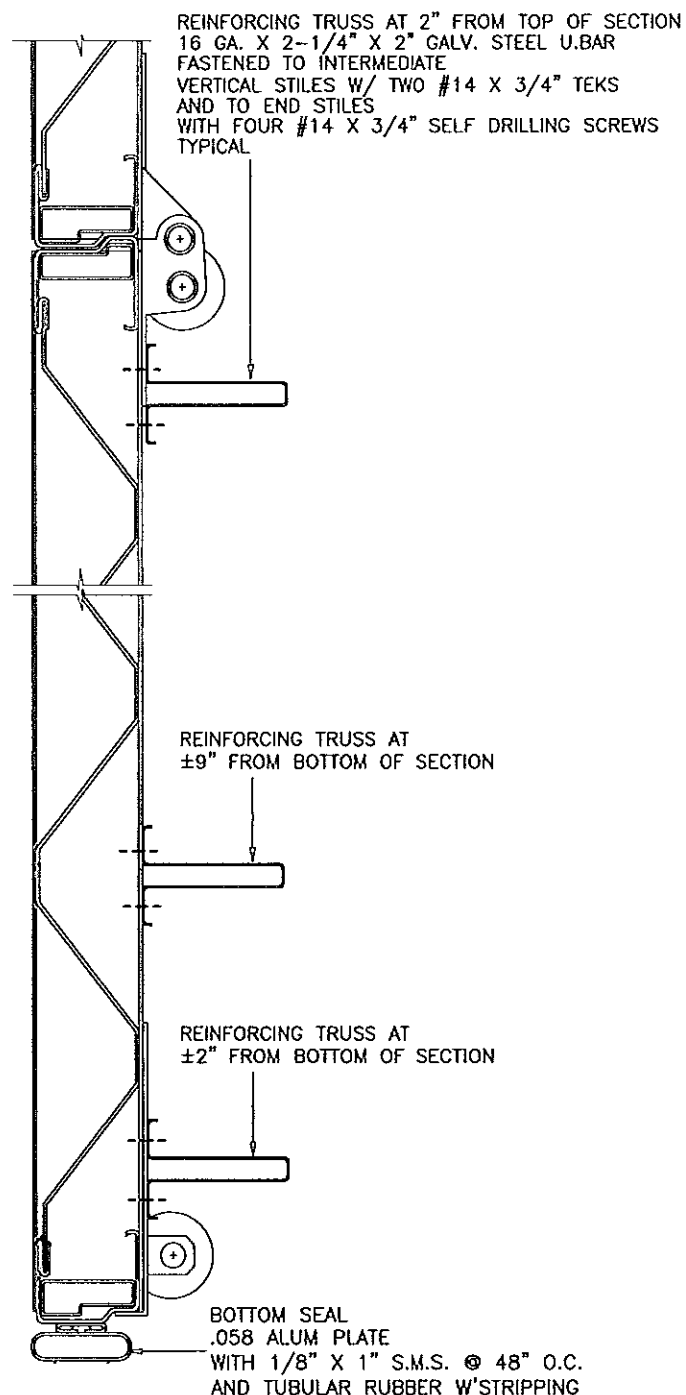

1ST SECTION (BOTTOM)
REINFORCING

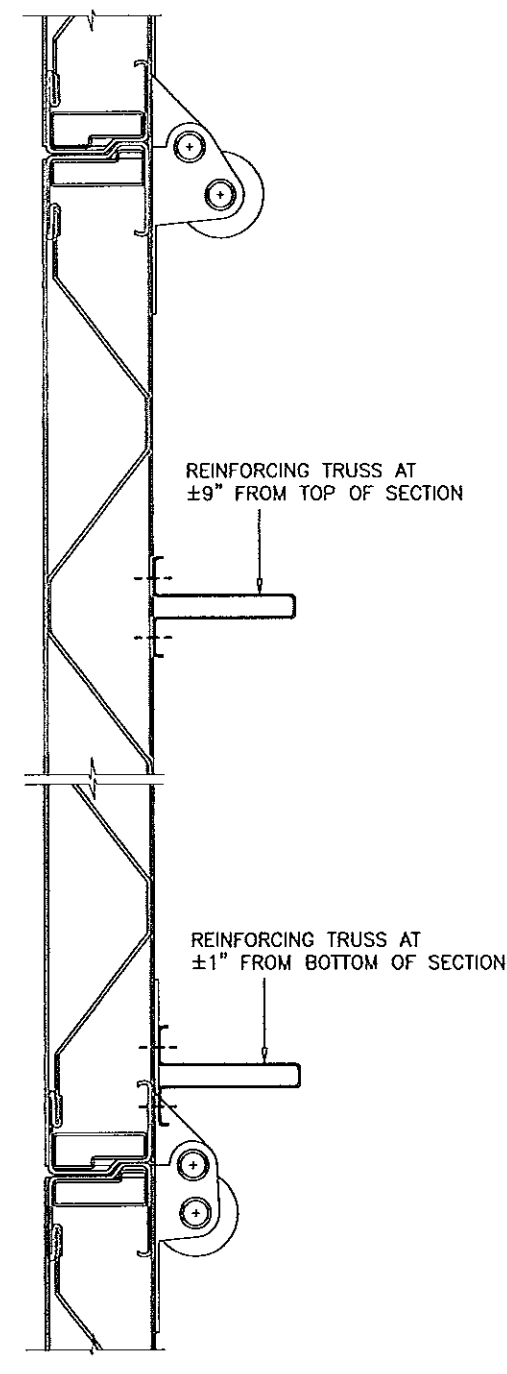

2ND SECTION (BOTTOM)
REINFORCING

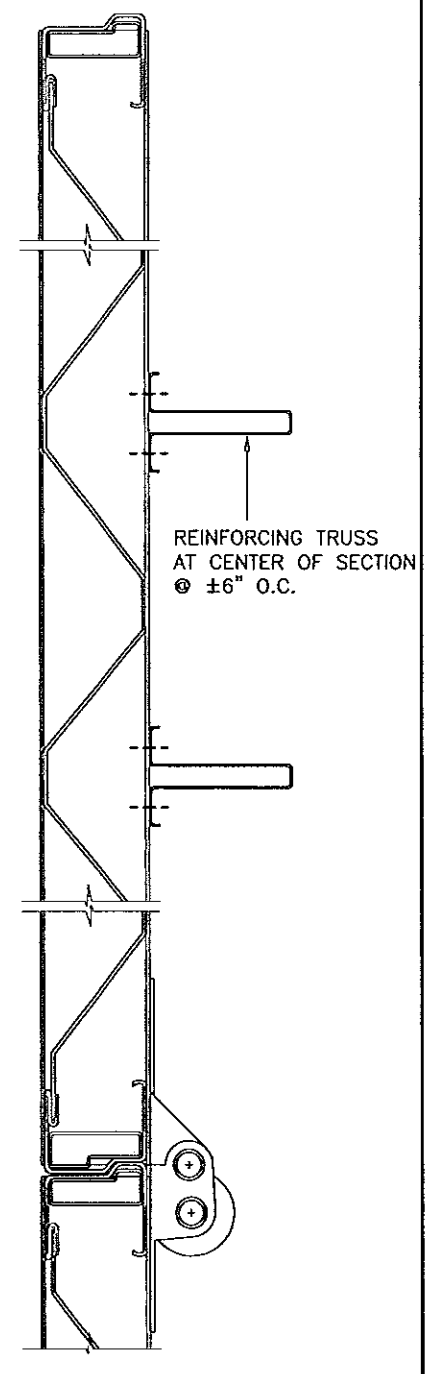

ALL TOP SECTIONS
REINFORCING

Engr: JAVAD AHMAD
 CIVIL
 FLA. PE # 70592
 C.A.N. 3538

SEP 29 2014

PRODUCT REVISED as complying with the Florida Building Code
 Acceptance No 14-1014-11
 Expiration Date 02/04/2019

By *[Signature]*
 Miami Dade Product Control

af c
AL-FAROOQ CORPORATION
 ENGINEERS & PRODUCT DEVELOPMENT
 1235 S.W. 87 AVE
 MIAMI, FLORIDA 33174
 TEL (305) 264-8100 FAX (305) 262-6978
 GARAGE\08-04JB

STEEL OVERHEAD GARAGE DOOR
J.B. GARAGE DOORS INC.
 12195 N.W. 98 TH. AVE.
 HIALEAH GARDENS, FL. 33016
 TEL. (305) 558 - 1658

revisions:

no	date	description
A	12.09.08	REV. PER BCCO COMMENTS
B	11.21.11	NO CHANGE THIS SHEET
C	09.22.14	UPDATED TO 2014 FBC

date: 04-03-08
 scale: NONE
 dr. by: HAMID
 chk. by:

drawing no.
08-04
 sheet 3 of 4

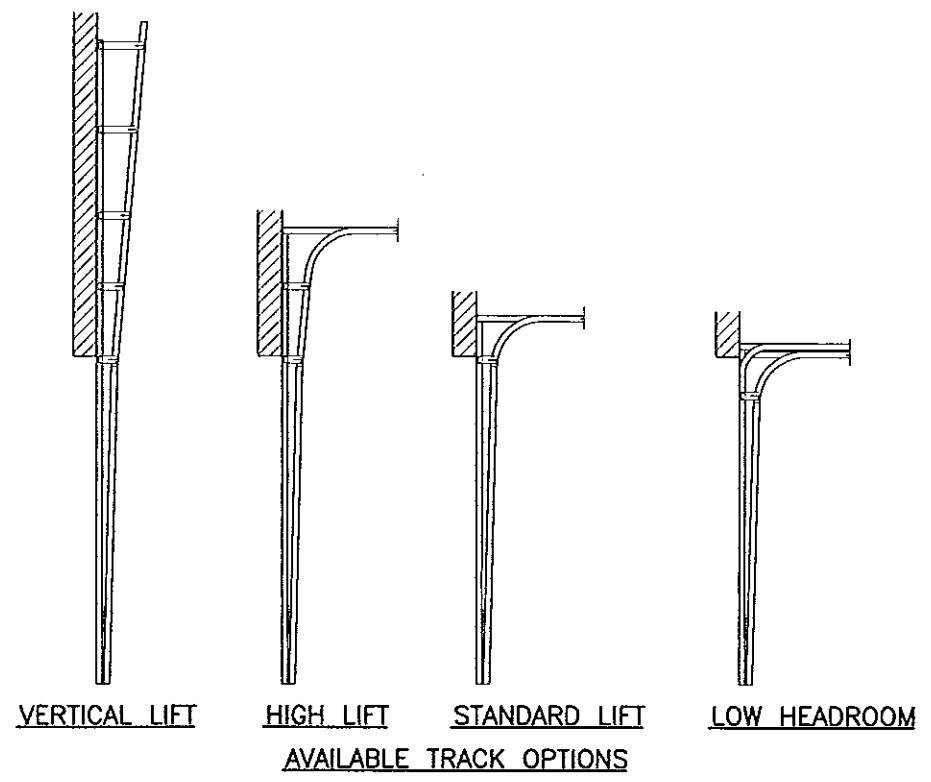
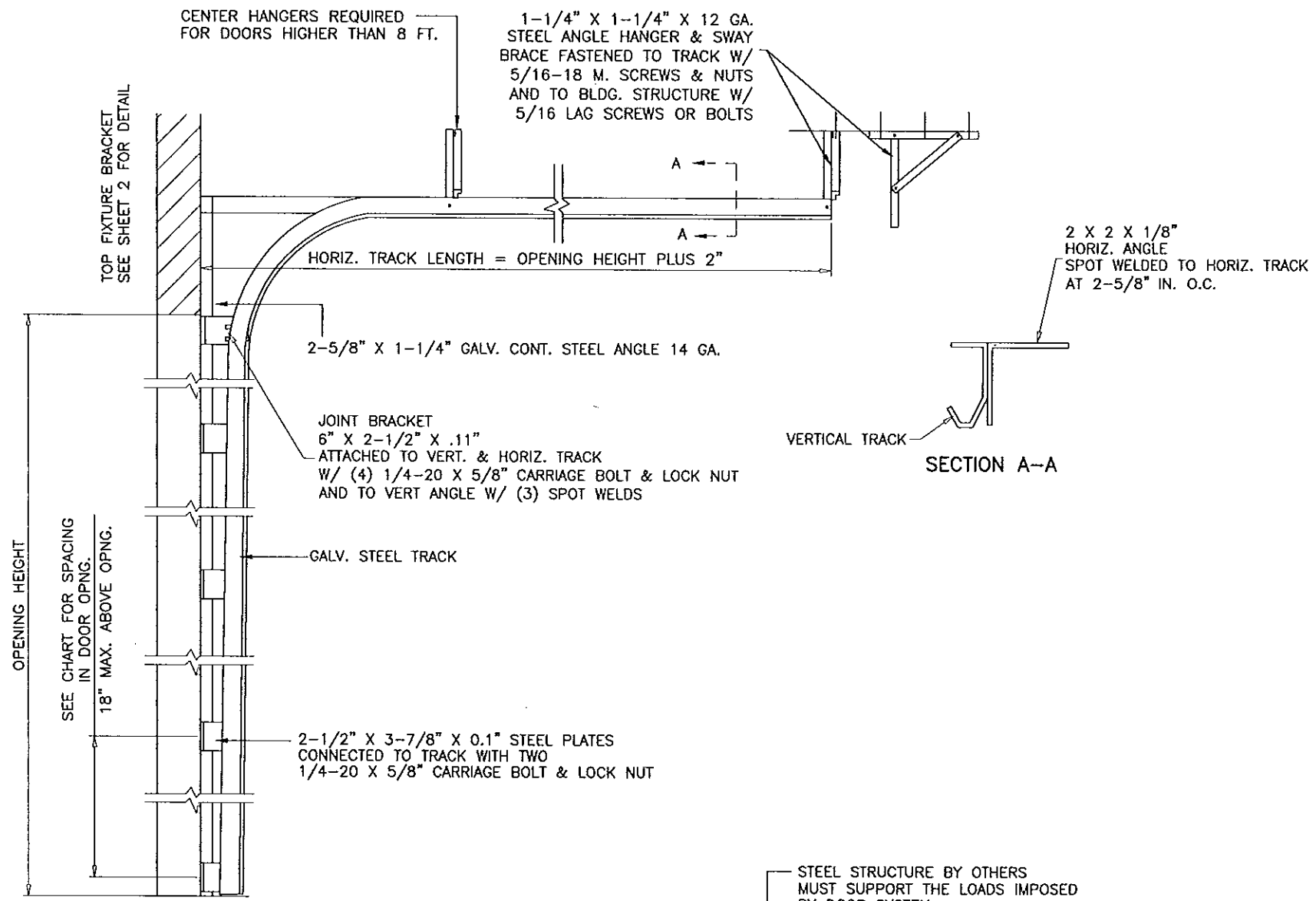

DOOR TRACK AS VIEWED FROM CENTER OF OPENING

DOOR HEIGHT	NO. OF TRUSSES	SECTION HEIGHTS *												
		1ST	2ND	3RD	4TH	5TH	6TH	7TH	8TH	9TH	10TH	11TH		
7'-0"	9	21"	21"	21"	21"	N/A	N/A	N/A	N/A	N/A	N/A	N/A	N/A	N/A
8'-0"	9	24"	24"	24"	24"	N/A	N/A	N/A	N/A	N/A	N/A	N/A	N/A	N/A
9'-0"	11	24"	21"	21"	21"	21"	N/A	N/A	N/A	N/A	N/A	N/A	N/A	N/A
10'-0"	11	24"	24"	24"	24"	24"	N/A	N/A	N/A	N/A	N/A	N/A	N/A	N/A
11'-0"	13	24"	24"	21"	21"	21"	21"	N/A	N/A	N/A	N/A	N/A	N/A	N/A
12'-0"	13	24"	24"	24"	24"	24"	24"	N/A	N/A	N/A	N/A	N/A	N/A	N/A
13'-0"	15	24"	24"	24"	21"	21"	21"	21"	N/A	N/A	N/A	N/A	N/A	N/A
14'-0"	15	24"	24"	24"	24"	24"	24"	24"	N/A	N/A	N/A	N/A	N/A	N/A
15'-0"	17	24"	24"	24"	24"	21"	21"	21"	21"	N/A	N/A	N/A	N/A	N/A
16'-0"	17	24"	24"	24"	24"	24"	24"	24"	24"	N/A	N/A	N/A	N/A	N/A
17'-0"	19	24"	24"	24"	24"	24"	21"	21"	21"	21"	N/A	N/A	N/A	N/A
18'-0"	19	24"	24"	24"	24"	24"	24"	24"	24"	24"	N/A	N/A	N/A	N/A
19'-0"	21	24"	24"	24"	24"	24"	24"	21"	21"	21"	21"	N/A	N/A	N/A
20'-0"	21	24"	24"	24"	24"	24"	24"	24"	24"	24"	24"	N/A	N/A	N/A
21'-0"	23	24"	24"	24"	24"	24"	24"	24"	21"	21"	21"	21"	N/A	N/A
22'-0"	23	24"	24"	24"	24"	24"	24"	24"	24"	24"	24"	24"	N/A	N/A

*-SECTIONS ARE NUMBERED STARTING AT THE BOTTOM

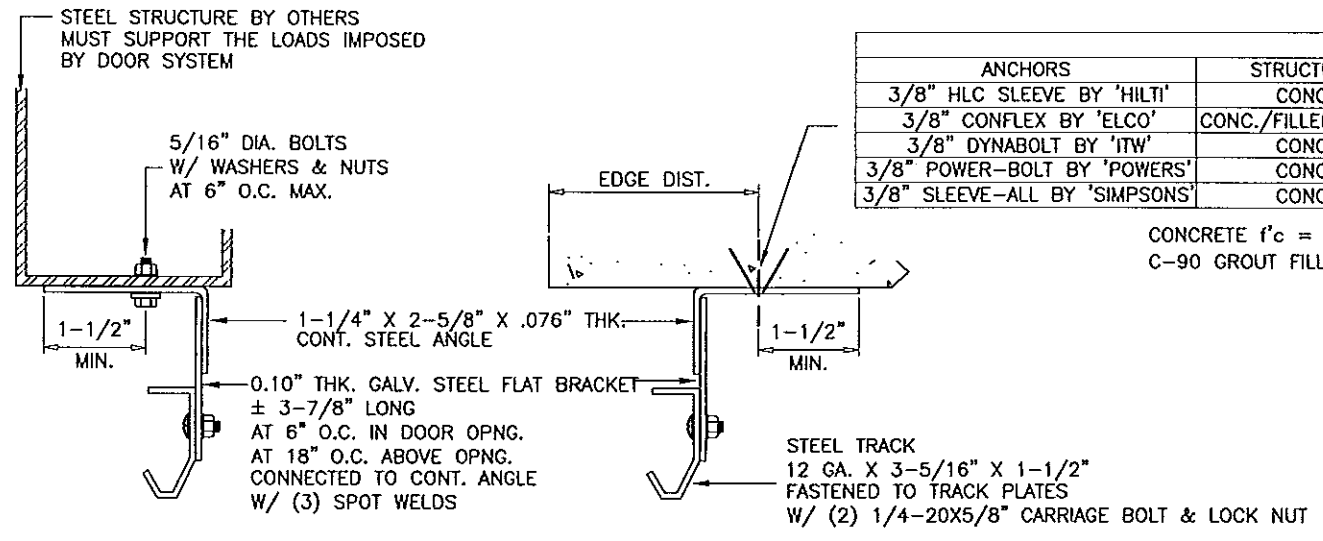

TRACK INSTALLATION

ANCHOR SPACING				
ANCHORS	STRUCTURE	EMBED	SPACING	EDGE DIST.
3/8" HLC SLEEVE BY 'HILTI'	CONC.	1-1/4"	6"	2-1/2"
3/8" CONFLX BY 'ELCO'	CONC./FILLED BLOCK	2"	8"	3-3/4"
3/8" DYNABOLT BY 'ITW'	CONC.	1-1/2"	6"	3-3/4"
3/8" POWER-BOLT BY 'POWERS'	CONC.	2"	6"	2-1/2"
3/8" SLEEVE-ALL BY 'SIMPSONS'	CONC.	1-1/2"	6"	3"

CONCRETE f'c = 3000 PSI MIN.
C-90 GROUT FILLED BLOCK f'm = 2000 PSI MIN.

Engr: JAVAD AHMAD
CIVIL
FLA. PE # 70592
C.A.N. 3538

SEP 29 2014

PRODUCT REVISED as complying with the Florida Building Code
Acceptance No 14-1914-11
Expiration Date 02/04/2019

By *[Signature]*
Miami Dade Product Control

afC
AL-FAROOQ CORPORATION
ENGINEERS & PRODUCT DEVELOPMENT
1235 S.W. 87 AVE
MIAMI, FLORIDA 33174
TEL (305) 264-8100 FAX (305) 262-6978
GARAGE\08-04JB

STEEL OVERHEAD GARAGE DOOR
J.B. GARAGE DOORS INC.
12195 N.W. 98 TH. AVE.
HIALEAH GARDENS, FL. 33016
TEL (305) 558 - 1658

no.	date	description
A	12.09.08	NO CHANGE THIS SHEET
B	11.21.11	NO CHANGE THIS SHEET
C	09.22.14	UPDATED TO 2014 FBC

date: 04-03-08
scale: NONE
dr. by: HAMD
chk. by:

drawing no.
08-04
sheet 4 of 4