



DEPARTMENT OF REGULATORY AND ECONOMIC RESOURCES (RER)  
BOARD AND CODE ADMINISTRATION DIVISION

**NOTICE OF ACCEPTANCE (NOA)**

MIAMI-DADE COUNTY  
PRODUCT CONTROL SECTION  
11805 SW 26 Street, Room 208  
Miami, Florida 33175-2474  
T (786) 315-2590 F (786) 315-2599  
[www.miamidade.gov/economy](http://www.miamidade.gov/economy)

**DAB Door Company, Inc.**  
12195 NW 98<sup>th</sup> Avenue  
Hialeah Gardens, FL 33018

**SCOPE:**

This NOA is being issued under the applicable rules and regulations governing the use of construction materials. The documentation submitted has been reviewed and accepted by Miami-Dade County RER-Product Control Section to be used in Miami Dade County and other areas where allowed by the Authority Having Jurisdiction (AHJ).

This NOA shall not be valid after the expiration date stated below. The Miami-Dade County Product Control Section (In Miami Dade County) and/or the AHJ (in areas other than Miami Dade County) reserve the right to have this product or material tested for quality assurance purposes. If this product or material fails to perform in the accepted manner, the manufacturer will incur the expense of such testing and the AHJ may immediately revoke, modify, or suspend the use of such product or material within their jurisdiction. RER reserves the right to revoke this acceptance, if it is determined by Miami-Dade County Product Control Section that this product or material fails to meet the requirements of the applicable building code.

This product is approved as described herein, and has been designed to comply with the Florida Building Code, including the High Velocity Hurricane Zone.

**DESCRIPTION: Hurricane Master Model 824/811 Steel Sectional Garage Door up to 16'-2" w/ Window Lite Option (DP +48.0, -52.0 PSF)**

**APPROVAL DOCUMENT:** Drawing No. 98-05, titled "24 GA. Roll Formed Steel Sectional Garage Door", dated 02/23/1998, with last revision L dated 03/05/2015, sheets 1 through 6 of 6, prepared by Al-Farooq Corporation, signed and sealed by Javad Ahmad, P.E., bearing the Miami-Dade County Product Control renewal stamp with the Notice of Acceptance number and expiration date by the Miami-Dade County Product Control Section.

**MISSILE IMPACT RATING: Large and Small Missile Impact Resistant**

**LABELING:** A permanent label with the manufacturer's name or logo, manufacturing address, model/series number, the positive and negative design pressure rating, indicate impact rated if applicable, installation instruction drawing reference number, approval number (NOA), the applicable test standards, and the statement reading 'Miami-Dade County Product Control Approved' is to be located on the door's side track, bottom angle, or inner surface of a panel.

**RENEWAL** of this NOA shall be considered after a renewal application has been filed and there has been no change in the applicable building code negatively affecting the performance of this product.

**TERMINATION** of this NOA will occur after the expiration date or if there has been a revision or change in the materials, use, and/or manufacture of the product or process. Misuse of this NOA as an endorsement of any product, for sales, advertising or any other purposes shall automatically terminate this NOA. Failure to comply with any section of this NOA shall be cause for termination and removal of NOA.

**ADVERTISEMENT:** The NOA number preceded by the words Miami-Dade County, Florida, and followed by the expiration date may be displayed in advertising literature. If any portion of the NOA is displayed, then it shall be done in its entirety.

**INSPECTION:** A copy of this entire NOA shall be provided to the user by the manufacturer or its distributors and shall be available for inspection at the job site at the request of the Building Official.

This NOA **renews NOA # 14-0814.08** and consists of this page 1 and evidence pages E-1 and E-2, as well as approval document mentioned above.

The submitted documentation was reviewed by **Carlos M. Utrera, P.E.**



*[Signature]*  
04/16/2015

NOA No. 15-0302.01  
Expiration Date: July 21, 2020  
Approval Date: April 23, 2015  
Page 1

NOTICE OF ACCEPTANCE: EVIDENCE SUBMITTED

**A. DRAWINGS**

1. Drawing No. **98-05**, titled "24 GA. Roll Formed Steel Sectional Garage Door", dated 02/23/1998, with last revision L dated 03/05/2015, sheets 1 through 6 of 6, prepared by Al-Farooq Corporation, signed and sealed by Javad Ahmad, P.E.

**B. TESTS "Submitted under NOA # 11-0414.13"**

1. Test Report on Uniform Static Air Pressure Test, Loading and Forced Entry Test per FBC, TAS 202-94, of "DAB 824 Sectional Residential Garage Door" prepared by Hurricane Engineering & Testing Inc., Report No. **HETI-07-4267**, dated 06/29/2007, signed and sealed by Candido F. Font, P.E.
2. Test Report on Large Missile Impact Test per FBC, TAS 201-94 and Cyclic Wind Pressure Test per FBC, TAS 203-94, of "DAB 824 Sectional Residential Garage Door", prepared by Hurricane Engineering & Testing Inc., Report No. **HETI-11-3206**, dated 02/10/2011, signed and sealed by Candido F. Font, P.E.
3. Test Report on Tensile Test per ASTM E8-08 of "Sectional Residential Door (skin)", prepared by Hurricane Engineering & Testing Inc, Report No. **HETI-11-T101**, dated 01/29/2011, signed and sealed by Candido F. Font, P.E.

**"Submitted under NOA # 05-0217.02"**

4. Test Report on Large Missile Impact Test and Cyclic Wind Pressure Test, of "Sectional Residential Door with Windows" prepared by Hurricane Engineering & Testing Inc., Test Report No. **HETI 03-1328**, dated 07/15/2003, signed and sealed by Rafael E. Droz-Seda, PE.
5. Test Report on Uniform Static Air Pressure Test, of "Sectional Residential Door" prepared by Hurricane Engineering & Testing Inc., Test Report No. **HETI 03-1329**, dated 07/15/2003 signed and sealed by Rafael E. Droz-Seda, P.E.
6. Test Report on Tensile Test per ASTM E-8 of "Sectional Residential Door (skin)" prepared by Hurricane Engineering & Testing Inc, Test Report No. **HETI 03-T078**, dated 10/31/2003, signed and sealed by Rafael E. Droz-Seda, P.E.

**"Submitted under NOA # 03-0210.04"**

7. Test report on Salt Spray (Corrosion) Test per ASTM B 117 of a painted G-40 steel panels, prepared by Celotex Corporation, Test Report No. **258592**, dated 08/17/1998, signed by W. A. Jackson, P.E.

**C. CALCULATIONS "Submitted under NOA # 14-0814.08"**

1. Anchor verification calculations prepared by Al-Farooq Corporation, dated 09/22/2014 and 07/24/2014, signed and sealed by Javad Ahmad, P.E.



---

Carlos M. Utrera, P.E.  
Product Control Examiner  
NOA No. 15-0302.01  
Expiration Date: July 21, 2020  
Approval Date: April 23, 2015

NOTICE OF ACCEPTANCE: EVIDENCE SUBMITTED

**C. CALCULATIONS (Cont.) “Submitted under NOA # 09-0128.01”**

1. Anchor verification calculations prepared by Al-Farooq Corporation, complying with F.B.C 2007, dated 04/05/2011, signed and sealed by Javad Ahmad, P.E.  
  
“Submitted under NOA # 09-0128.01”
2. Anchor verification calculations prepared by Al-Farooq Corporation, complying with F.B.C 2007, dated 12/18/2008, signed and sealed by Humayoun Farooq, P.E.

**D. QUALITY ASSURANCE**

1. Miami-Dade Department of Regulatory and Economic Resources (RER)

**E. MATERIAL CERTIFICATIONS**

1. Notice of Acceptance No. **13-0717.01**, issued to SABIC Innovative Plastics, for their Lexan Sheet Products, approved on 11/28/2013 and expiring on 07/17/2018.
2. Notice of Acceptance No. **14-0311.08**, issued to Insulfoam, LLC, for their Insulfoam Expanded Polystyrene Insulation, approved on 08/14/2014 and expiring on 11/29/2017.
3. Notice of Acceptance No. **11-0926.07**, issued to Dyplast Products, LLC, for their Expanded Polystyrene Block Type Insulation, approved on 11/10/2011 and expiring on 01/11/2017.
4. Notice of Acceptance No. **11-0926.06**, issued to Dyplast Products, LLC, for their Dyplast ISO-C1 Polyisocyanurate Insulation, approved on 11/10/2011 and expiring on 01/11/2017.
5. Notice of Acceptance No. **10-1129.04**, issued to Cellofoam North America Inc, for their Expanded Polystyrene Block Insulation, approved on 02/24/2011 and expiring on 02/24/2016.  
  
“Submitted under NOA # 05-0228.02”
6. Test Report on Accelerated Weathering Using Xenon Arc Light Apparatus Test per ASTM G155 of “PVC Extrusion Material”, prepared by Hurricane Engineering & Testing, Inc., Report No. **HETI 04-A002**, dated 09/27/2004, signed and sealed by Rafael E. Droz-Seda, P.E.
7. Test Reports on Tensile Test per ASTM D638 of “PVC Extrusion Material”, prepared by Hurricane Engineering & Testing Inc., Report No. **HETI 04-T251**, dated 11/29/2004 signed and sealed by I. Ghia, P.E.
8. Test Report on Self-Ignition Temperature Test, Rate of Burn Test and Smoke Density Test of “REHAU non-foam PVC extrusion material”, prepared by ETC Laboratories, Report No. **04-761-15019.0**, dated 05/06/2004, signed and sealed by J. L. Doldan, P.E.

**F. STATEMENTS “Submitted under NOA # 14-0814.08”**

1. Statement letter of code conformance to the 5<sup>th</sup> edition (2014) FBC and no financial interest issued by Al-Farooq Corporation, dated 05/13/2014, signed and sealed by Javad Ahmad, P.E.



09/16/2015

---

Carlos M. Utrera, P.E.  
Product Control Examiner  
NOA No. 15-0302.01  
Expiration Date: July 21, 2020  
Approval Date: April 23, 2015

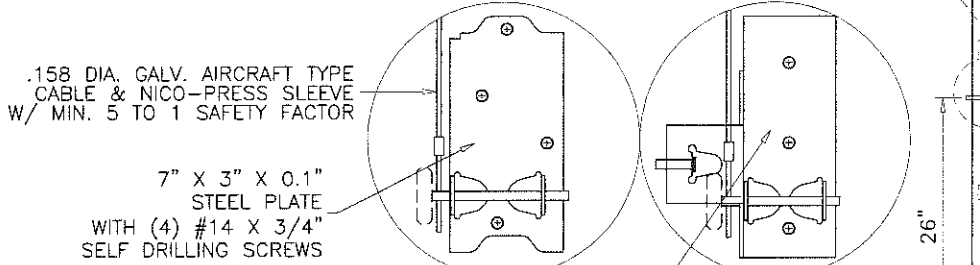
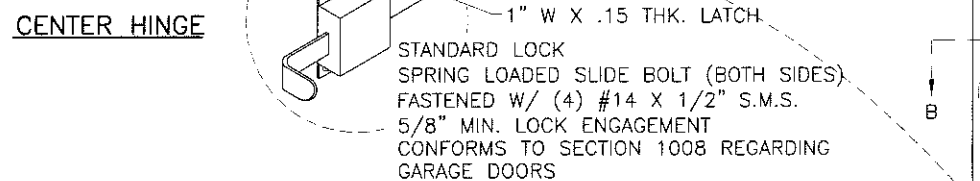
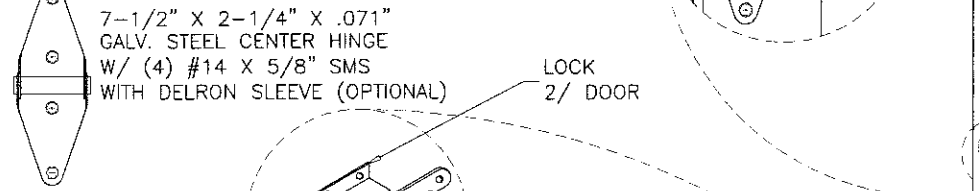
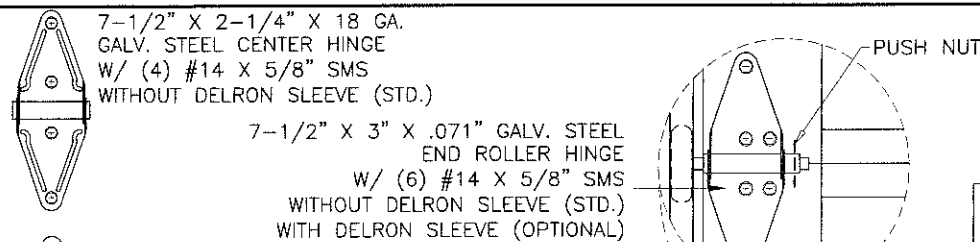

DOOR HEIGHT	CONSISTS OF	TOTAL # OF 'U' BARS AT EACH DOOR
6'-6"	2 SECTIONS 18" 2 SECTIONS 21"	3
6'-9"	1 SECTION 18" 3 SECTIONS 21"	
7'	4 SECTIONS 21"	
7'-3"	-	
7'-6"	5 SECTIONS 18"	
7'-9"	4 SECTIONS 18" 1 SECTION 21"	
8'	3 SECTIONS 18" 2 SECTIONS 21"	
8'-3"	2 SECTIONS 18" 3 SECTIONS 21"	
8'-6"	1 SECTION 18" 4 SECTIONS 21"	
8'-9"	5 SECTIONS 21"	
9'	6 SECTIONS 18"	4
9'-3"	5 SECTIONS 18" 1 SECTION 21"	
9'-6"	4 SECTIONS 18" 2 SECTIONS 21"	
9'-9"	3 SECTIONS 18" 3 SECTIONS 21"	
10'	2 SECTIONS 18" 4 SECTIONS 21"	
10'-3"	1 SECTION 18" 5 SECTIONS 21"	
10'-6"	6 SECTIONS 21"	
10'-9"	6 SECTIONS 18" 1 SECTION 21"	
11'	5 SECTIONS 18" 2 SECTIONS 21"	
11'-3"	4 SECTIONS 18" 3 SECTIONS 21"	
11'-6"	3 SECTIONS 18" 4 SECTIONS 21"	
11'-9"	2 SECTIONS 18" 5 SECTIONS 21"	
12'	1 SECTION 18" 6 SECTIONS 21"	
12'-3"	7 SECTIONS 21"	5
12'-6"	6 SECTIONS 18" 2 SECTIONS 21"	
12'-9"	5 SECTIONS 18" 3 SECTIONS 21"	
13'	4 SECTIONS 18" 4 SECTIONS 21"	
13'-3"	3 SECTIONS 18" 5 SECTIONS 21"	
13'-6"	2 SECTIONS 18" 6 SECTIONS 21"	
13'-9"	1 SECTION 18" 7 SECTIONS 21"	
14'	8 SECTIONS 21"	
14'-3"	6 SECTIONS 18" 3 SECTIONS 21"	
14'-6"	5 SECTIONS 18" 4 SECTIONS 21"	
14'-9"	4 SECTIONS 18" 5 SECTIONS 21"	
15'	3 SECTIONS 18" 6 SECTIONS 21"	
15'-3"	2 SECTIONS 18" 7 SECTIONS 21"	6
15'-6"	1 SECTION 18" 8 SECTIONS 21"	
15'-9"	9 SECTIONS 21"	
16'	6 SECTIONS 18" 4 SECTIONS 21"	

REFER TO SHEET 2 FOR U-BAR PLACEMENT

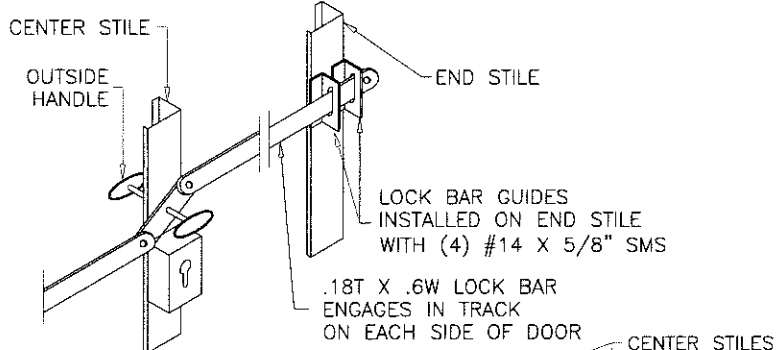
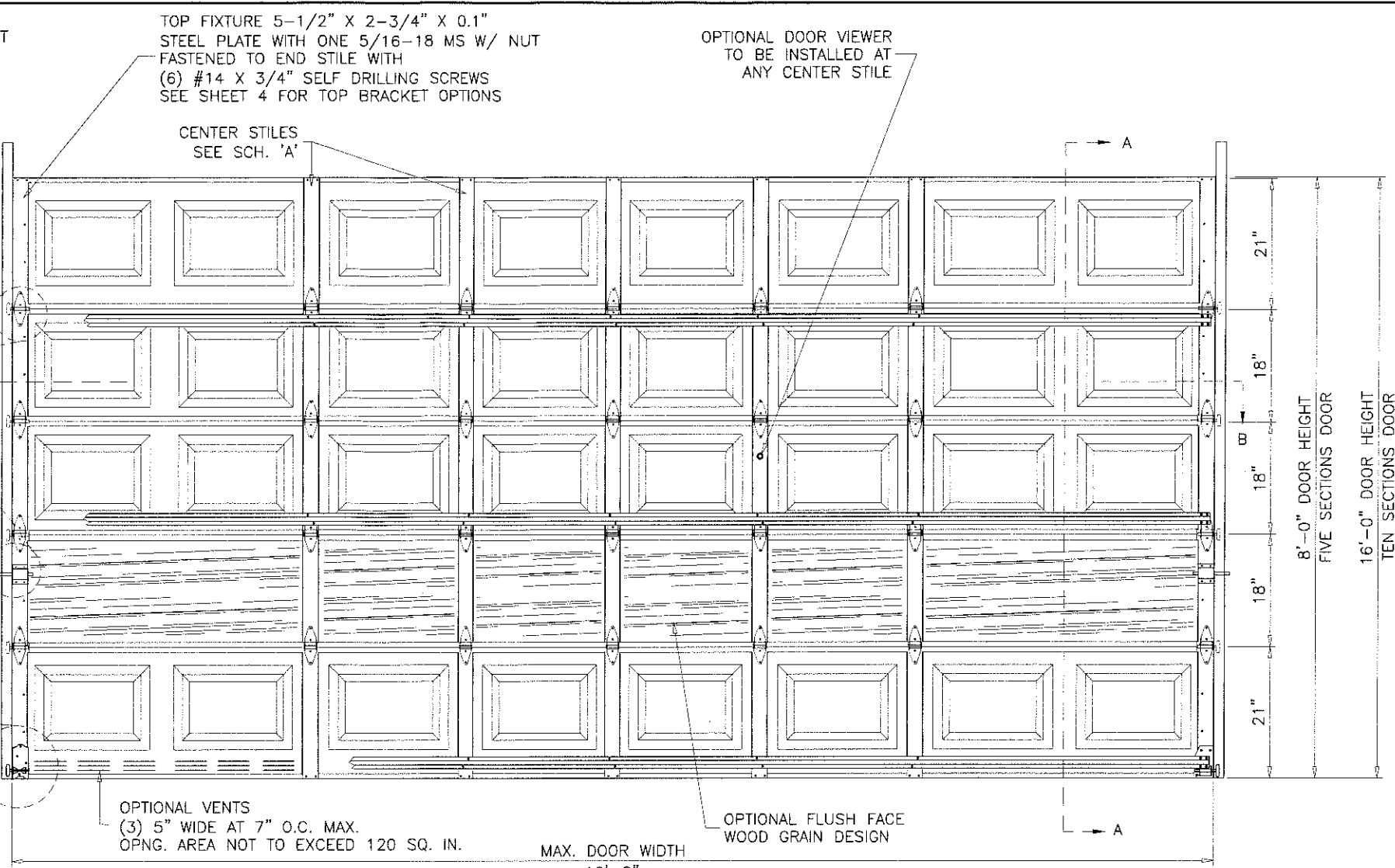

**OUTSIDE KEYPED LOCK OPTIONAL**

LOCK BAR LOCKING SHOWN ALTERNATE TO SPRING LOADED SLIDE BOLT LOCKS SHOWN ABOVE

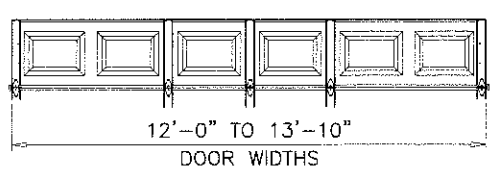
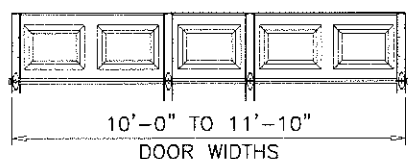
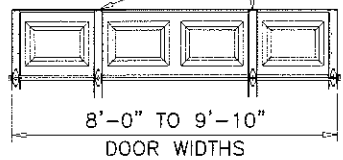

SCHEDULE 'A'

DOOR WIDTHS	# OF CENTER STILES
8'-0" TO 9'-10"	2
10'-0" TO 11'-10"	2
12'-0" TO 13'-10"	3
14'-0" TO 15'-10"	4
15'-11" TO 16'-2"	5

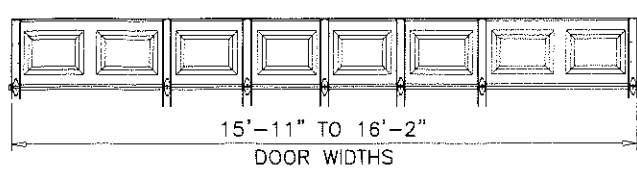
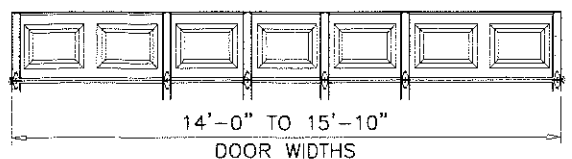

**INSIDE ELEVATION**  
RAISED PANEL EMBOSSED DOOR

#14 X 3/4" SELF DRILLING SCREWS MAY BE USED IN LIEU OF #14 X 5/8" SMS

THIS PRODUCT IS RATED FOR LARGE MISSILE IMPACT

**DAB DOORS INC.**  
Hurricane Master® Model 824/811  
Max. Size 16'-2" X 16'-0" High  
With Window Lite Option

DESIGN PRESSURE RATING = + 48.0 PSF  
- 52.0 PSF

**GENERAL NOTES**

- THIS PRODUCT HAS BEEN DESIGNED AND TESTED TO COMPLY WITH THE REQUIREMENTS OF THE FLORIDA BUILDING CODE (FBC) FIFTH EDITION (2014) INCLUDING HIGH VELOCITY HURRICANE ZONE (HVHZ).
- ANCHORS SHALL BE AS LISTED, SPACED AS SHOWN ON DETAILS. ANCHOR EMBEDMENT TO BASE MATERIAL SHALL BE BEYOND WALL DRESSING OR STUCCO.
- ALL BOLTS, NUTS AND WASHERS SHALL BE ZINC PLATED CARBON STEEL.
- ANCHORING OR LOADING CONDITIONS OTHER THAN THOSE SHOWN IN THESE DETAILS ARE NOT PART OF THIS APPROVAL.
- A LOAD DURATION INCREASE IS USED IN DESIGN OF ANCHORS INTO WOOD ONLY.

DOOR TESTED IN ACCORDANCE WITH THE REQUIREMENTS OF FLORIDA BUILDING CODE, TAS-202, TAS-201 & TAS-203 FOR HVHZ AND ASTM E1886-05/ASTM E1996-09.

Engr: JAVAD AHMAD  
CIVIL  
FLA. PE # 70592  
C.A.N. 3538

MAR 30 2015

**PRODUCT RENEWED**  
as complying with the Florida Building Code  
Acceptance No 150302.01  
Expiration Date 07/21/2020

By *[Signature]*  
Miami Trade Product Control

**af c**

**AL-FAROOQ CORPORATION**  
ENGINEERS & PRODUCT DEVELOPMENT  
1235 S.W. 87 AVE  
MIAMI, FLORIDA 33174  
TEL. (305) 264-8100 FAX. (305) 262-6978  
GARAGE\98-05DAB

24 GA. ROLL FORMED STEEL SECTIONAL GARAGE DR.

**DAB DOORS INC.**  
12195 N.W. 98 TH. AVE.  
HIALEAH GARDENS, FL. 33018  
TEL. (305) 556 - 6624

no	date	description	by
H	10.13.11	UPDATED TO 2010 FBC	
I	07.21.14	GENERAL REVISION	
J	09.16.14	NO CHANGE THIS SHEET	
K	11.07.14	NO CHANGE THIS SHEET	
L	03.05.15	NO CHANGE THIS SHEET	

date: 02-23-98  
scale: 1/2" = 1'-0"  
dr. by: HAMID  
chk. by:

drawing no.  
**98-05**

sheet 1 of 6

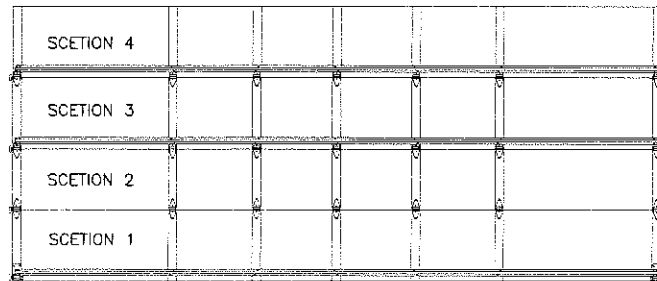

**4 SECTION DOOR**  
HEIGHT RANGE 6'-6" TO 7'-0"  
(3) U-BARS

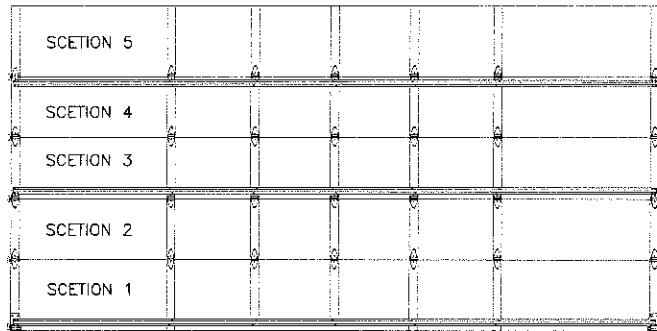

**5 SECTION DOOR**  
HEIGHT RANGE 7'-6" TO 8'-0"  
(3) U-BARS

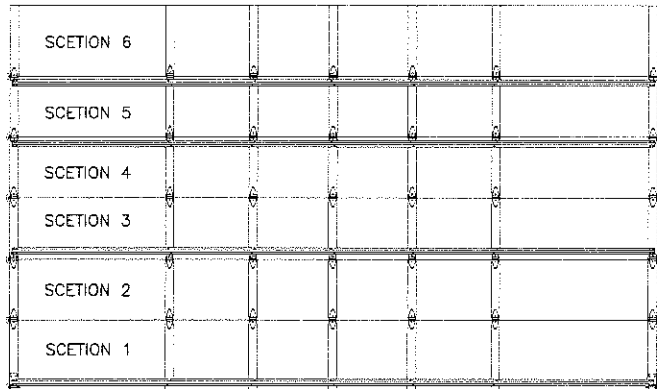

**6 SECTION DOOR**  
HEIGHT RANGE 9'-0" TO 10'-3"  
(4) U-BARS

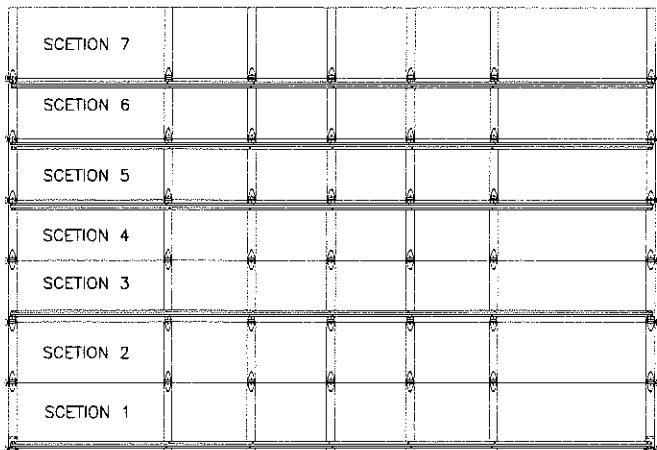

**7 SECTION DOOR**  
HEIGHT RANGE 10'-9" TO 12'-3"  
(5) U-BARS

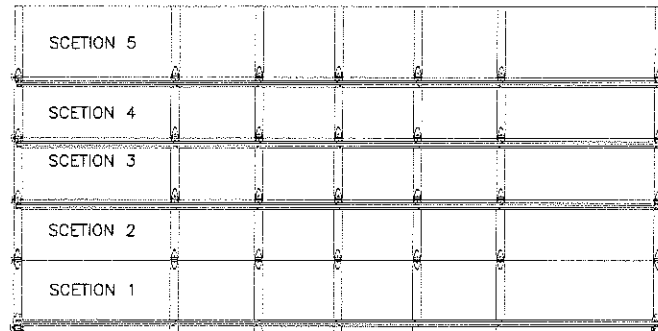

**5 SECTION DOOR**  
HEIGHT RANGE 8'-3" TO 8'-9"  
(4) U-BARS

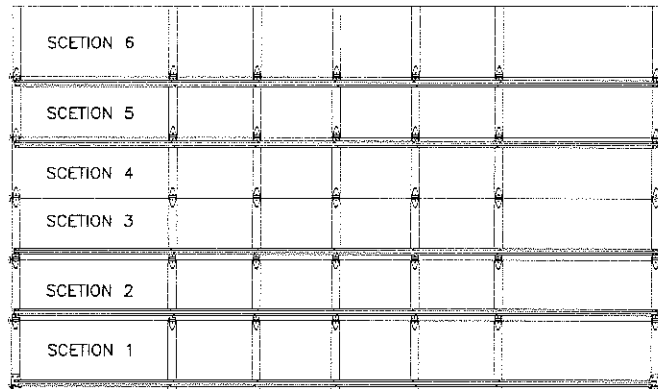

**6 SECTION DOOR**  
HEIGHT RANGE 10'-6"  
(5) U-BARS

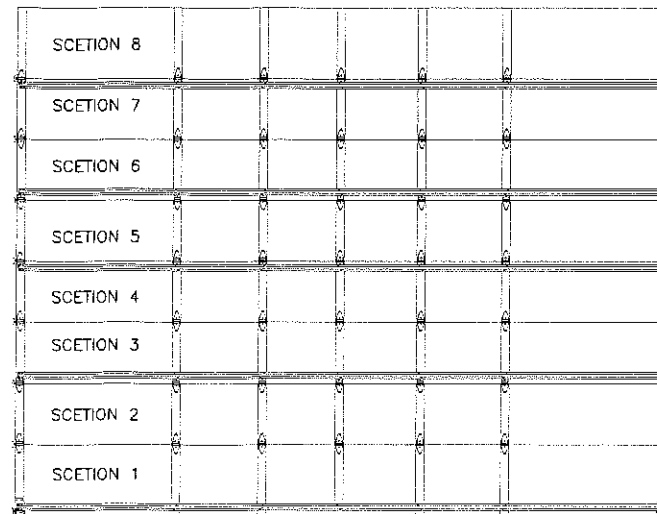

**8 SECTION DOOR**  
HEIGHT RANGE 12'-6" TO 13'-3"  
(5) U-BARS

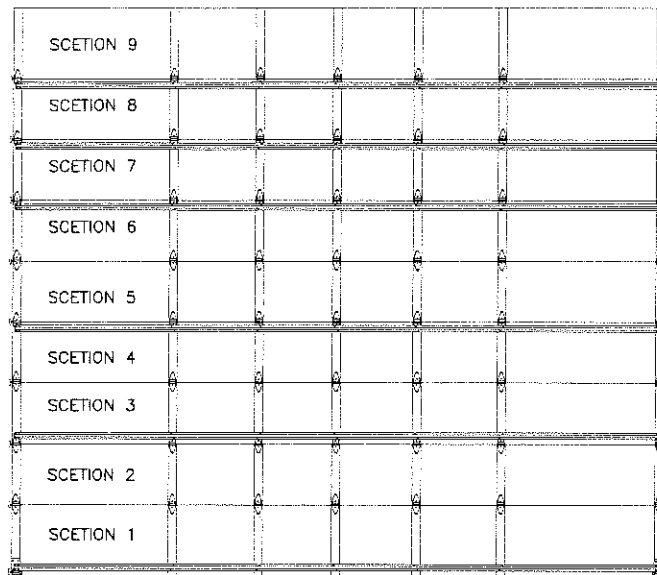

**9 SECTION DOOR**  
HEIGHT RANGE 14'-3" TO 15'-9"  
(6) U-BARS

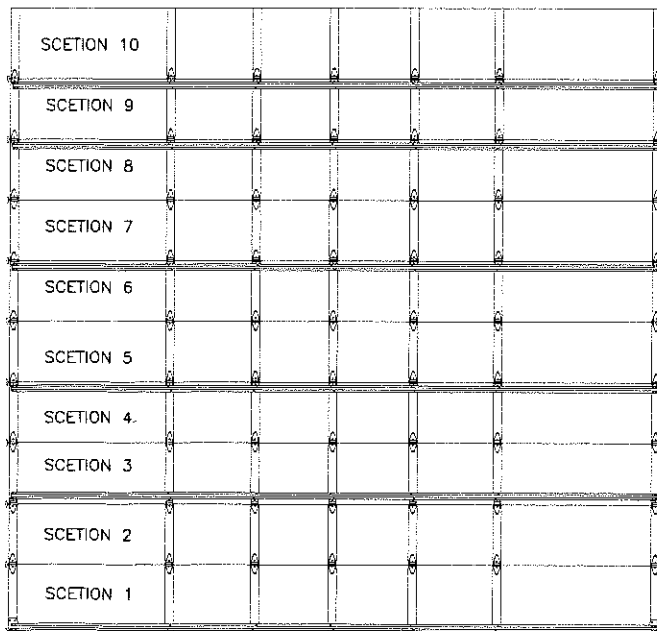

**10 SECTION DOOR**  
HEIGHT RANGE 16'-0"  
(6) U-BARS

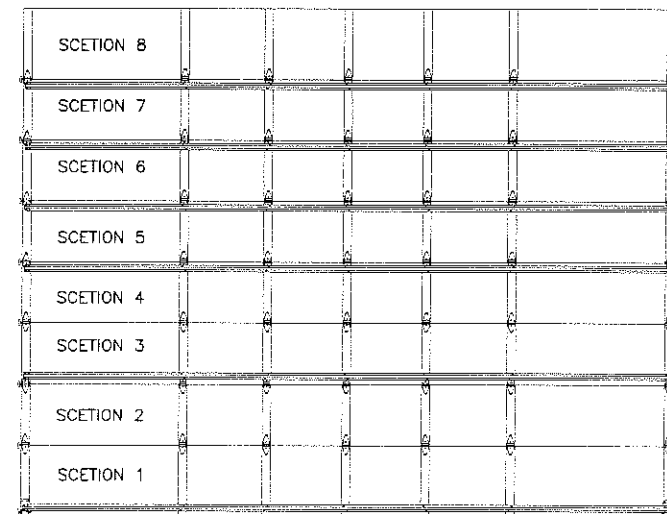

**8 SECTION DOOR**  
HEIGHT RANGE 13'-6" TO 14'-0"  
(6) U-BARS



**9 SECTION DOOR**  
HEIGHT RANGE 14'-3" TO 15'-9"  
(6) U-BARS

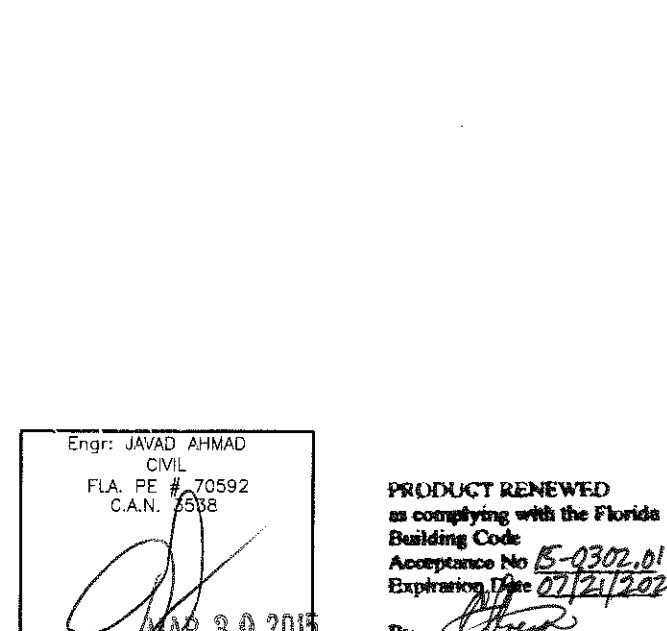

**10 SECTION DOOR**  
HEIGHT RANGE 16'-0"  
(6) U-BARS

Engr: JAVAD AHMAD  
CIVIL  
FLA. PE # 70592  
C.A.N. 5538

*[Signature]*  
MAR 30 2015

**PRODUCT RENEWED**  
as complying with the Florida  
Building Code  
Acceptance No 15-0302.01  
Expiration Date 07/21/2020

By *[Signature]*  
Miami Date Product Control

**AL-FAROOQ CORPORATION**  
ENGINEERS & PRODUCT DEVELOPMENT  
1235 S.W. 87 AVE  
MIAMI, FLORIDA 33174  
TEL. (305) 264-8100 FAX. (305) 262-6978  
GARAGE/98-05DAB

24 GA. ROLL FORMED STEEL SECTIONAL GARAGE DR.  
**DAB DOORS INC.**  
12195 N.W. 98 TH. AVE.  
HIALEAH GARDENS, FL. 33018  
TEL. (305) 556 - 6624

no	date	description
H	10.13.11	NO CHANGE THIS SHEET
I	07.21.14	NO CHANGE THIS SHEET
J	09.16.14	NO CHANGE THIS SHEET
K	11.07.14	NO CHANGE THIS SHEET
L	03.05.15	NO CHANGE THIS SHEET

date: 02-23-98  
scale: 1/2" = 1'-0"  
dr. by: HAMID  
chk. by:

drawing no.  
**98-05**  
sheet 2 of 6

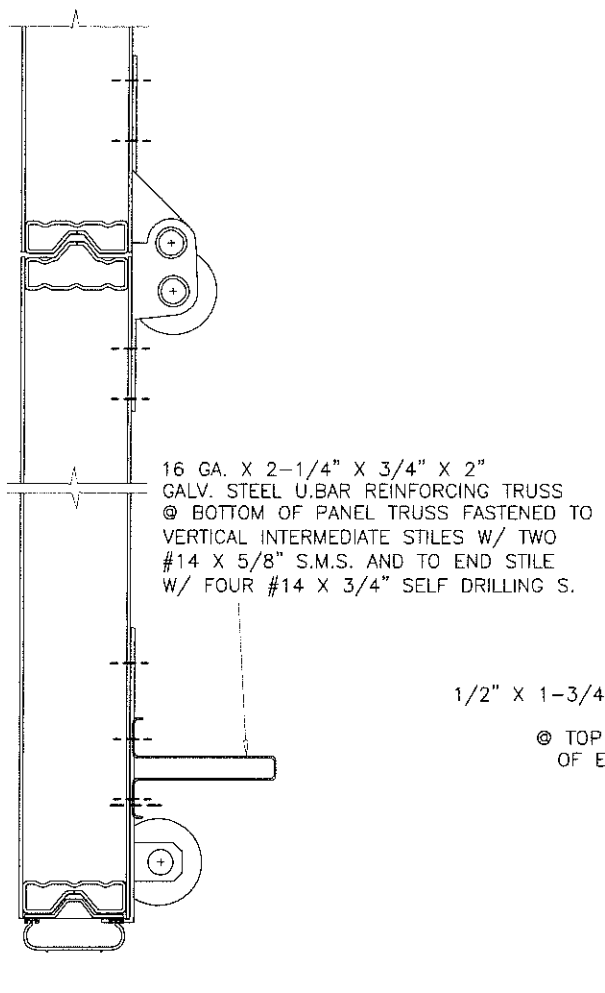

**1ST SECTION (BOTTOM)**  
REINFORCING

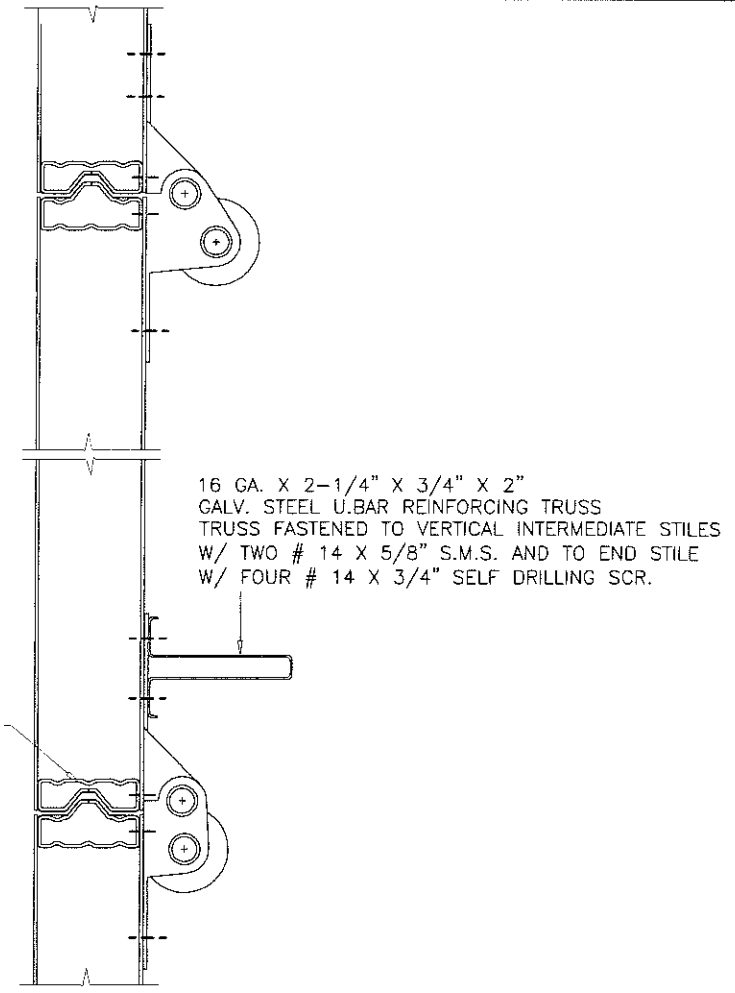

**INTERMEDIATE SECTIONS**  
REINFORCING

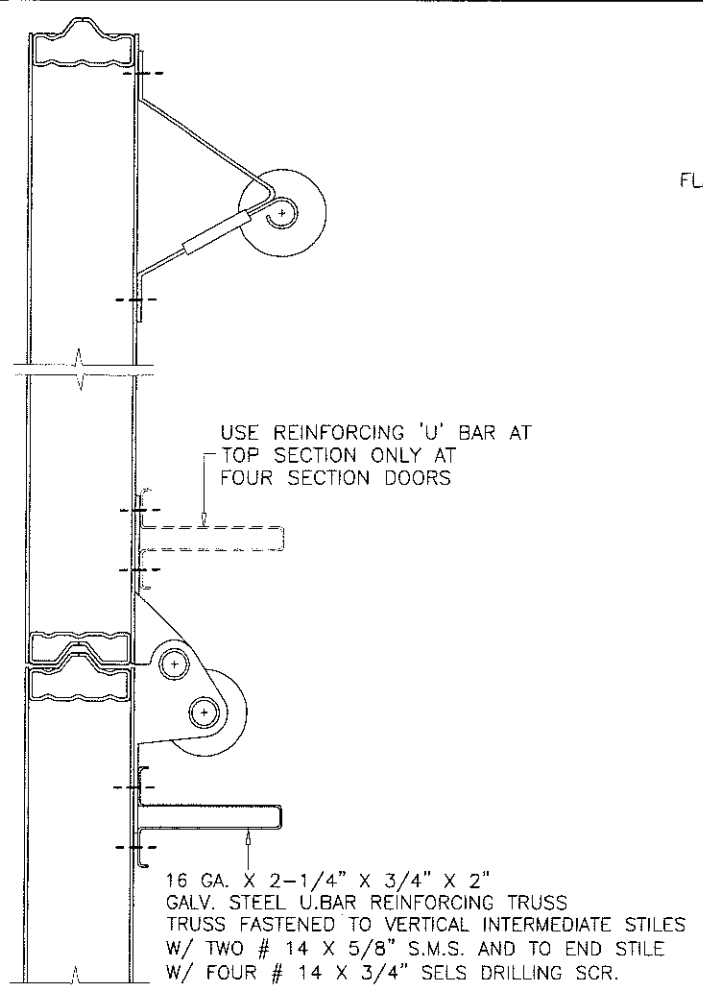

**TOP SECTION**

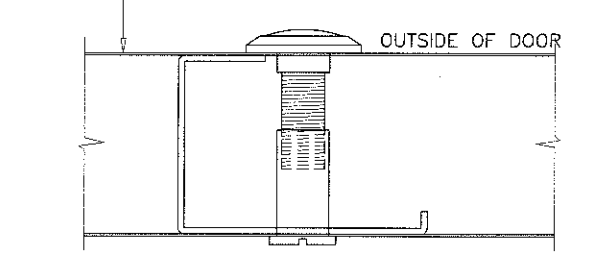
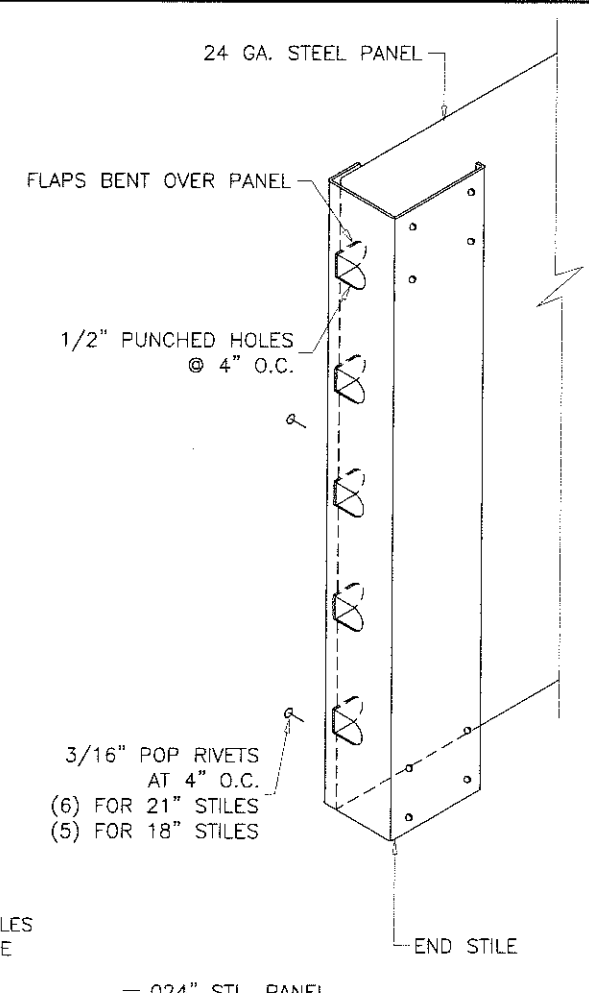

**SOLID BRASS DOOR VIEWER**  
BY 'SCHLAGE SECURITY HARDWARE'  
INSTALLED IN 9/16\"/>

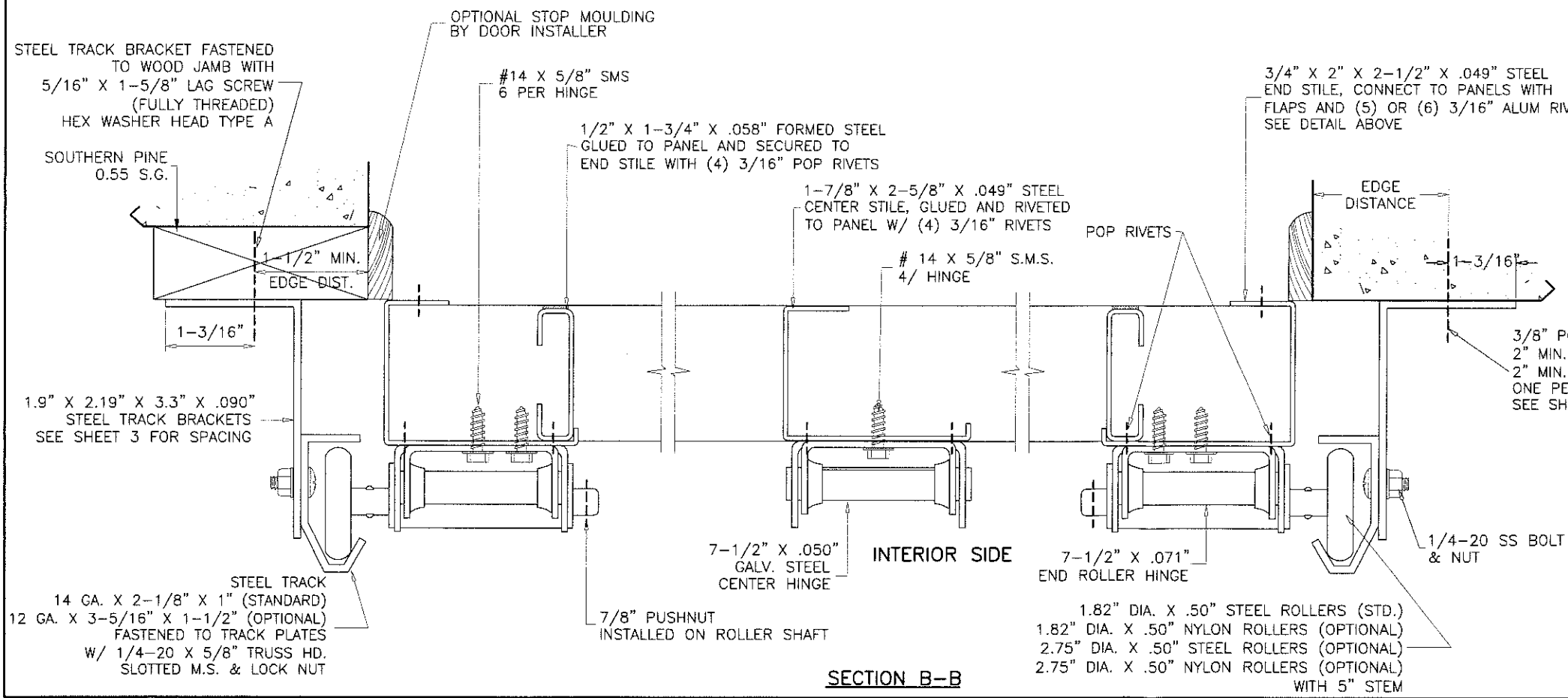

**SECTION B-B**

Engr: JAVAD AHMAD  
CIVIL  
FLA. PE # 70592  
C.A.N. 3538

*[Signature]*  
MAR 30 2015

**PRODUCT RENEWED**  
as complying with the Florida  
Building Code  
Acceptance No 15-0302.01  
Expiration Date 07/21/2020

By *[Signature]*  
Miami Trade Product Control

**af c**  
**AL-FAROOQ CORPORATION**  
ENGINEERS & PRODUCT DEVELOPMENT  
1235 S.W. 87 AVE  
MIAMI, FLORIDA 33174  
TEL. (305) 264-8100 FAX. (305) 262-6978  
GARAGE\98-05DAB

24 GA. ROLL FORMED STEEL SECTIONAL GARAGE DR.  
**DAB DOORS INC.**  
12195 N.W. 98 TH. AVE.  
HIALEAH GARDENS, FL. 33018  
TEL. (305) 556 - 6624

no	date	by	description
H	10.13.11		NO CHANGE THIS SHEET
I	07.21.14		GENERAL REVISION
J	09.16.14		NO CHANGE THIS SHEET
K	11.07.14		NO CHANGE THIS SHEET
L	03.05.15		NO CHANGE THIS SHEET

date: 02-23-98  
scale: -  
dr. by: HAMID  
chk. by:  
drawing no.  
**98-05**  
sheet 3 of 6

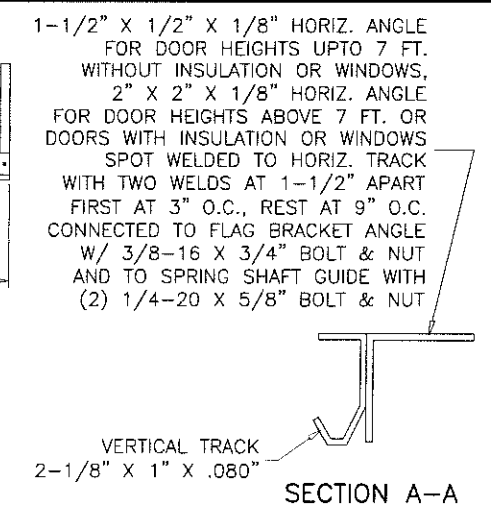
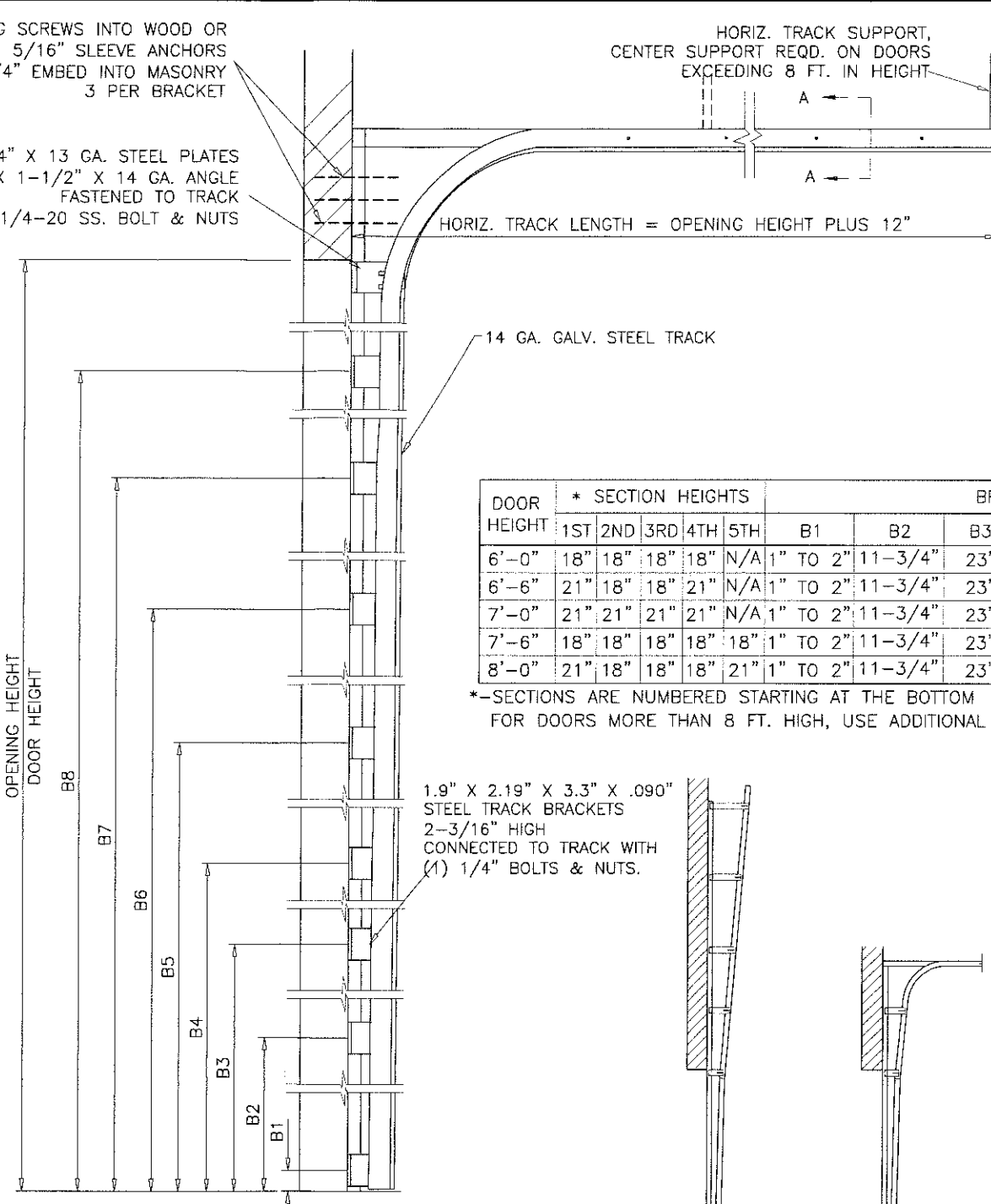
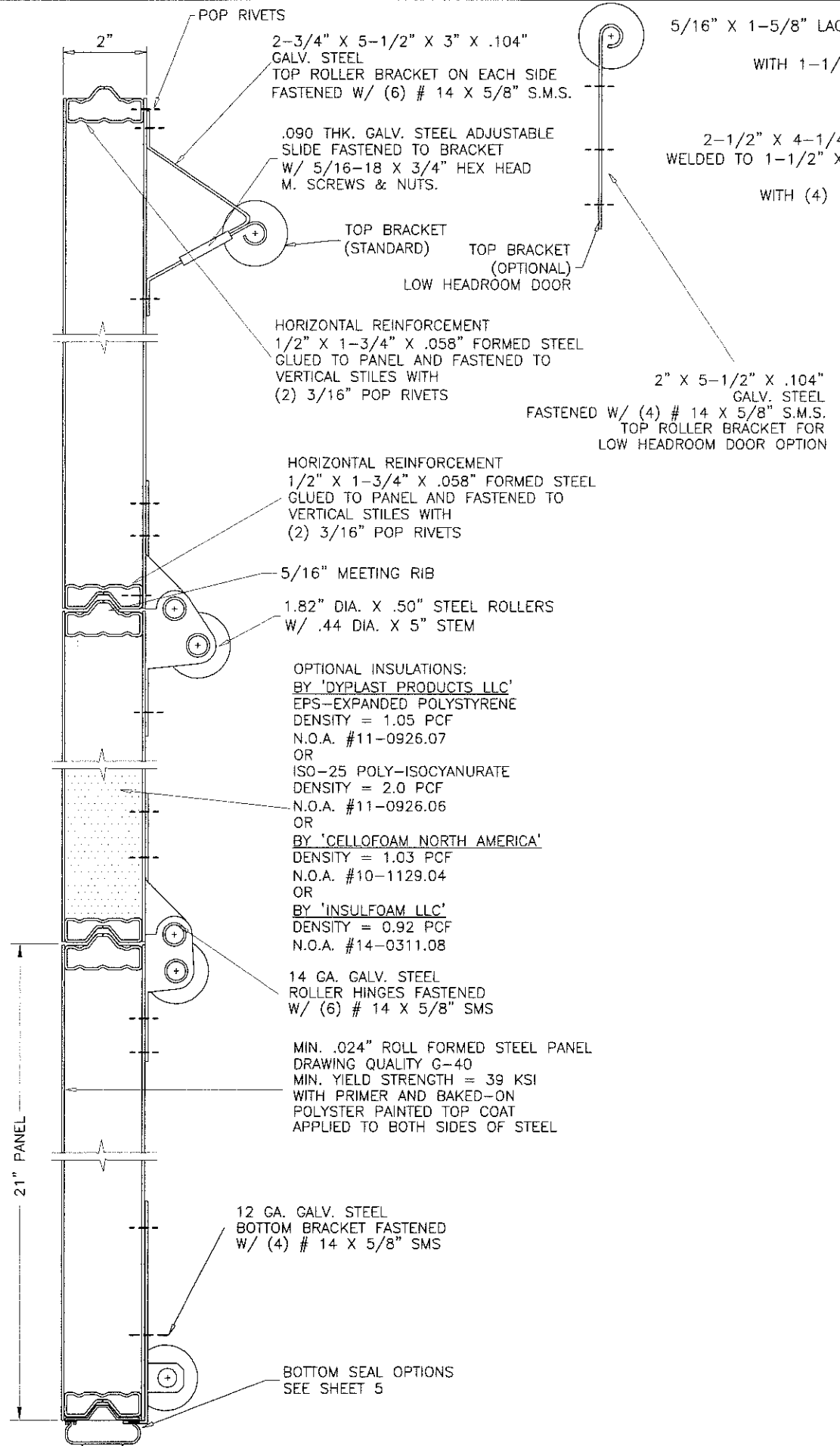

DOOR HEIGHT	* SECTION HEIGHTS					BRACKET PLACEMENTS							
	1ST	2ND	3RD	4TH	5TH	B1	B2	B3	B4	B5	B6	B7	B8
6'-0"	18"	18"	18"	18"	N/A	1" TO 2"	11-3/4"	23"	34"	45"	56"	67"	-
6'-6"	21"	18"	18"	21"	N/A	1" TO 2"	11-3/4"	23"	34"	45"	56"	67"	-
7'-0"	21"	21"	21"	21"	N/A	1" TO 2"	11-3/4"	23"	34"	45"	56"	67"	-
7'-6"	18"	18"	18"	18"	18"	1" TO 2"	11-3/4"	23"	34"	45"	56"	67"	78-1/4"
8'-0"	21"	18"	18"	18"	21"	1" TO 2"	11-3/4"	23"	34"	45"	56"	67"	78-1/4"

\*-SECTIONS ARE NUMBERED STARTING AT THE BOTTOM FOR DOORS MORE THAN 8 FT. HIGH, USE ADDITIONAL TRACK BRACKETS AT 10" O.C.

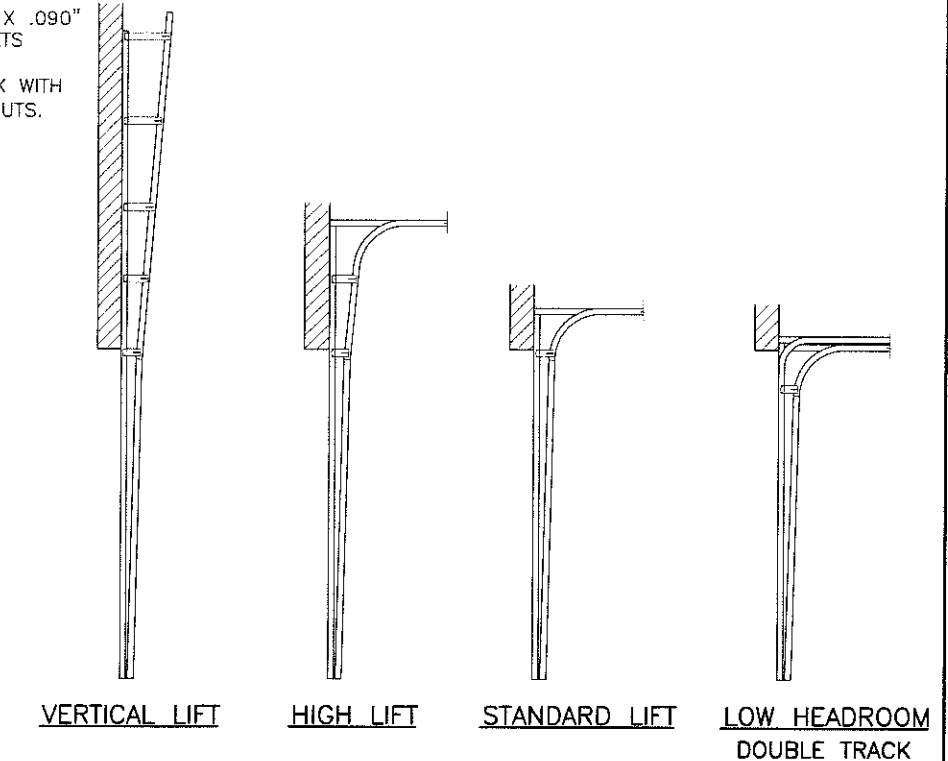

AVAILABLE TRACK OPTIONS

Engr: JAVAD AHMAD CIVIL  
 FLA. PE # 70592  
 C.A.N. 3538

MAR 30 2015

PRODUCT RENEWED as complying with the Florida Building Code  
 Acceptance No 15-0302-01  
 Expiration Date 07/21/2020

By *[Signature]*  
 Miami Trade Product Control

**AL-FAROOQ CORPORATION**  
 ENGINEERS & PRODUCT DEVELOPMENT  
 1235 S.W. 87 AVE  
 MIAMI, FLORIDA 33174  
 TEL. (305) 264-8100 FAX. (305) 262-6978  
 GARAGE/98-05DAB

24 GA. ROLL FORMED STEEL SECTIONAL GARAGE DR.  
**DAB DOORS INC.**  
 12195 N.W. 98 TH. AVE.  
 HIALEAH GARDENS, FL. 33018  
 TEL. (305) 556 - 6624

Revisions:

no	date	by	description
H	10.13.11		NO CHANGE THIS SHEET
I	07.21.14		GENERAL REVISION
J	09.16.14		FOAM NOA REV.
K	11.07.14		NO CHANGE THIS SHEET
L	03.05.15		BOTTOM SEAL OPTION ADDED

date: 02-23-98  
 scale: -  
 dr. by: HAMID  
 chk. by:

drawing no. 98-05  
 sheet 4 of 6

SECTION A-A  
 SEE SHEET 2 FOR LOCATION OF REINFORCING TRUSSES

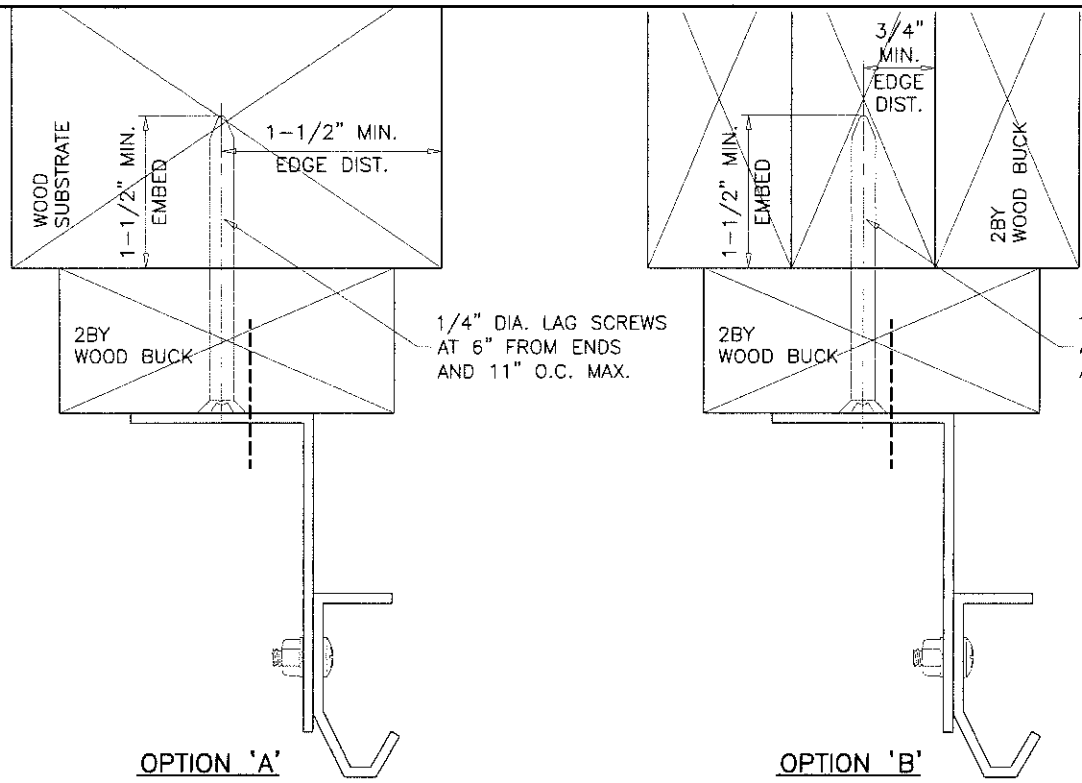

OPTION 'A'

OPTION 'B'

**WOOD BUCK CONNECTION TO WOOD SUBSTRATE (WOOD SPECIFIC GRAVITY SG=0.55 MIN.)**

THE INSTALLATION METHODS SHOWN ABOVE SHOWS 2X6 SYP WOOD BUCK ATTACHMENT TO WOOD STRUCTURES. IF THESE METHODS ARE FOLLOWED NO ADDITIONAL CALCULATIONS/DESIGN WILL BE REQUIRED FOR DESIGN OF GARAGE DOOR ANCHORAGE. FOR DOOR REPLACEMENT APPLICATIONS WITH NO ENGINEER OF RECORD, INSTALLATION MAY BE VERIFIED AND APPROVED BY THE BUILDING OFFICIAL UPON INSPECTION.

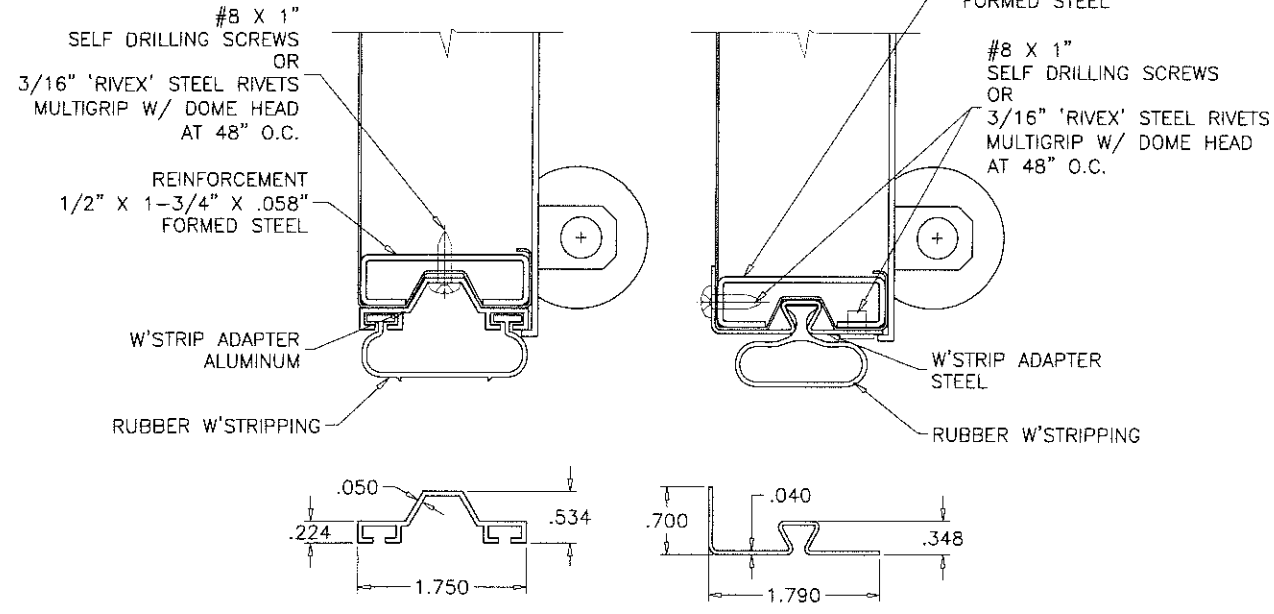

**BOTTOM SEAL OPTIONS**

**WOOD BUCK CONNECTION TO MASONRY**

PRESSURE TREATED 2X6 SYP WOOD JAMBS WHICH SHALL BE ANCHORED TO GROUTED REINFORCED MASONRY BLOCK WALL OR CONC. COLUMN WITH

1/4" ULTRACON BY 'ELCO' WITH SPACING OF 12" O.C. INTO GROUT FILLED BLOCK WALL, WITH 2-1/4" MIN. EMBED 9" O.C. INTO 3000 PSI CONCRETE, WITH 1-3/4" MIN. EMBED 2-1/2" MIN. EDGE DISTANCE

1/4" TAPPER BY 'POWERS' WITH SPACING OF 8" O.C. INTO GROUT FILLED BLOCK WALL, WITH 1-1/2" MIN. EMBED 9" O.C. INTO 3000 PSI CONCRETE, WITH 1-3/4" MIN. EMBED 3" MIN. EDGE DISTANCE

3/8" CONFLX BY 'ELCO' OR 3/8" LDT BY 'ITW' WITH SPACING OF 21" O.C. INTO 3000 PSI CONCRETE, WITH 2-1/2" MIN. EMBED 3" MIN. EDGE DISTANCE

3/8" HLC SLEEVE BY 'HILTI' WITH SPACING OF 8" O.C. INTO GROUT FILLED BLOCK WALL, WITH 1-1/4" MIN. EMBED, 4" MIN. EDGE DIST. 11" O.C. INTO 3000 PSI CONCRETE, WITH 1-1/4" MIN. EMBED AND 2-1/2" MIN. EDGE DISTANCE

**PREPARATION OF JAMBS BY OTHERS**

FOR NEW CONSTRUCTION ENGINEER OF RECORD OR ARCHITECT TO VERIFY ADEQUACY OF SUPPORTING STRUCTURE TO SUPPORT LOADS IMPOSED BY DOOR SYSTEM.

FOR DOOR REPLACEMENT IN RETROFIT BUILDINGS WITH NO ENGINEER OF RECORD, DOOR INSTALLATION MAY BE REVIEWED AND APPROVED BY BUILDING OFFICIAL UPON INSPECTION.

MAXIMUM EXTERIOR(+) LOAD PER JAMB = (16.17' X 48 PSF)/2 = 388 Lbs per Ft.  
 MAXIMUM INTERIOR(-) LOAD PER JAMB = (16.17' X 70 PSF)/2 = 420.4 Lbs per Ft.

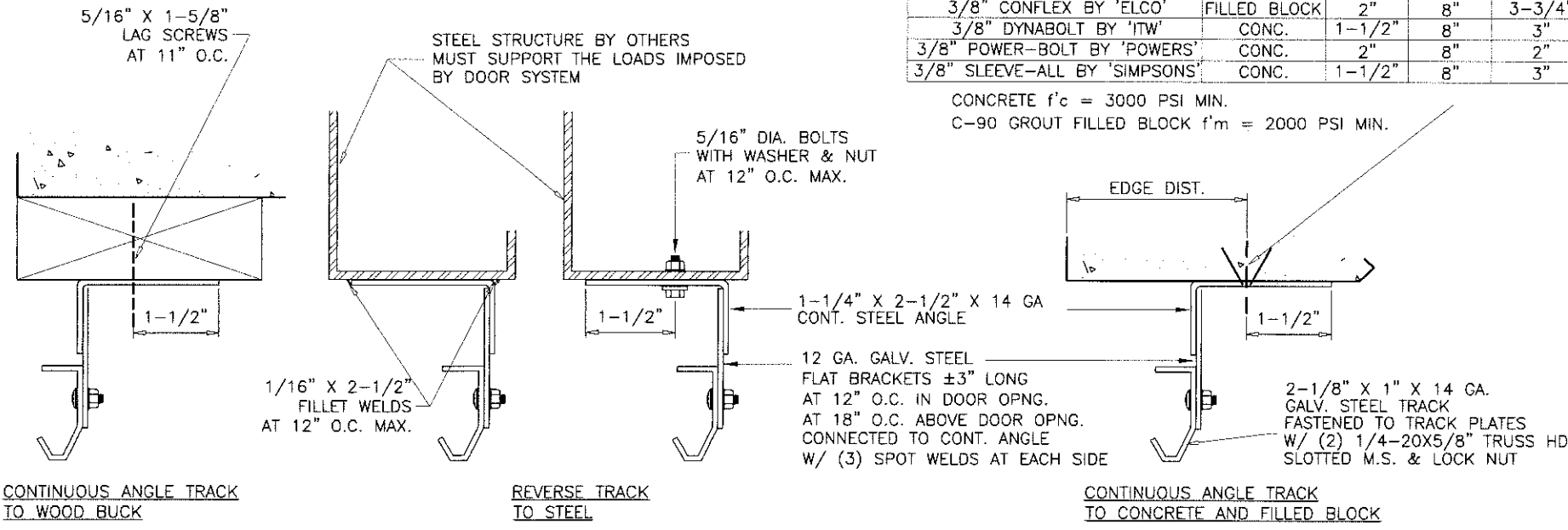

**ALTERNATE TRACK INSTALLATION**

ANCHOR SPACING				
ANCHORS	STRUCTURE	EMBED	SPACING	EDGE DIST.
3/8" HLC SLEEVE BY 'HILTI'	CONC.	1-1/4"	8"	2"
3/8" CONFLX BY 'ELCO'	FILLED BLOCK	2"	8"	3-3/4"
3/8" DYNABOLT BY 'ITW'	CONC.	1-1/2"	8"	3"
3/8" POWER-BOLT BY 'POWERS'	CONC.	2"	8"	2"
3/8" SLEEVE-ALL BY 'SIMPSONS'	CONC.	1-1/2"	8"	3"

CONCRETE f'c = 3000 PSI MIN.  
 C-90 GROUT FILLED BLOCK f'm = 2000 PSI MIN.

**AL-FAROOQ CORPORATION**  
 ENGINEERS & PRODUCT DEVELOPMENT  
 1235 S.W. 87 AVE  
 MIAMI, FLORIDA 33174  
 TEL. (305) 264-8100 FAX. (305) 262-6978  
 GARAGE 98-05DAB

24 GA. ROLL FORMED STEEL SECTIONAL GARAGE DR.  
**DAB DOORS INC.**  
 12195 N.W. 98 TH. AVE.  
 HIALEAH GARDENS, FL. 33018  
 TEL. (305) 556 - 6624

no	date	description
H	10.13.11	NO CHANGE THIS SHEET
I	07.21.14	GENERAL REVISION
J	09.16.14	ANCHORS REVISION
K	11.07.14	REV. PER RFR COMMENTS
L	03.05.15	BOTTOM SEAL OPTION ADDED

Engr: JAVAD AHMAD  
 CIVIL  
 FLA. PE. # 70592  
 C.A.N. # 3538  
 MAR 30 2015

**PRODUCT RENEWED**  
 as complying with the Florida Building Code  
 Acceptance No 15-0002-01  
 Expiration Date 07/21/2020  
 By: *[Signature]*  
 Miami Dade Product Control

date: 02-23-98  
 scale: -  
 dr. by: HAMID  
 chk. by:  
 drawing no. 98-05  
 sheet 5 of 6



\* PLASTIC COMPLIES WITH  
CHAPTER 26 OF FBC  
SEE EVIDENCE PAGE

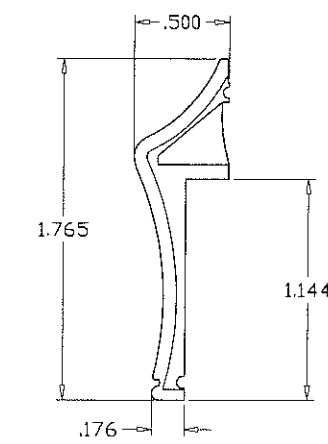

\* EXTERIOR FRAME  
RIGID PVC ONE PIECE INJECTION

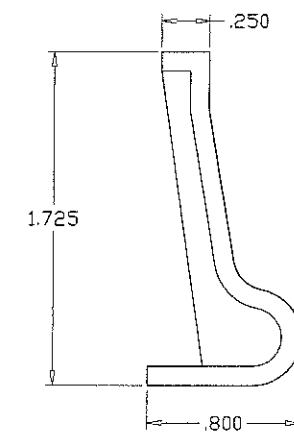

\* INTERIOR FRAME  
RIGID PVC ONE PIECE INJECTION

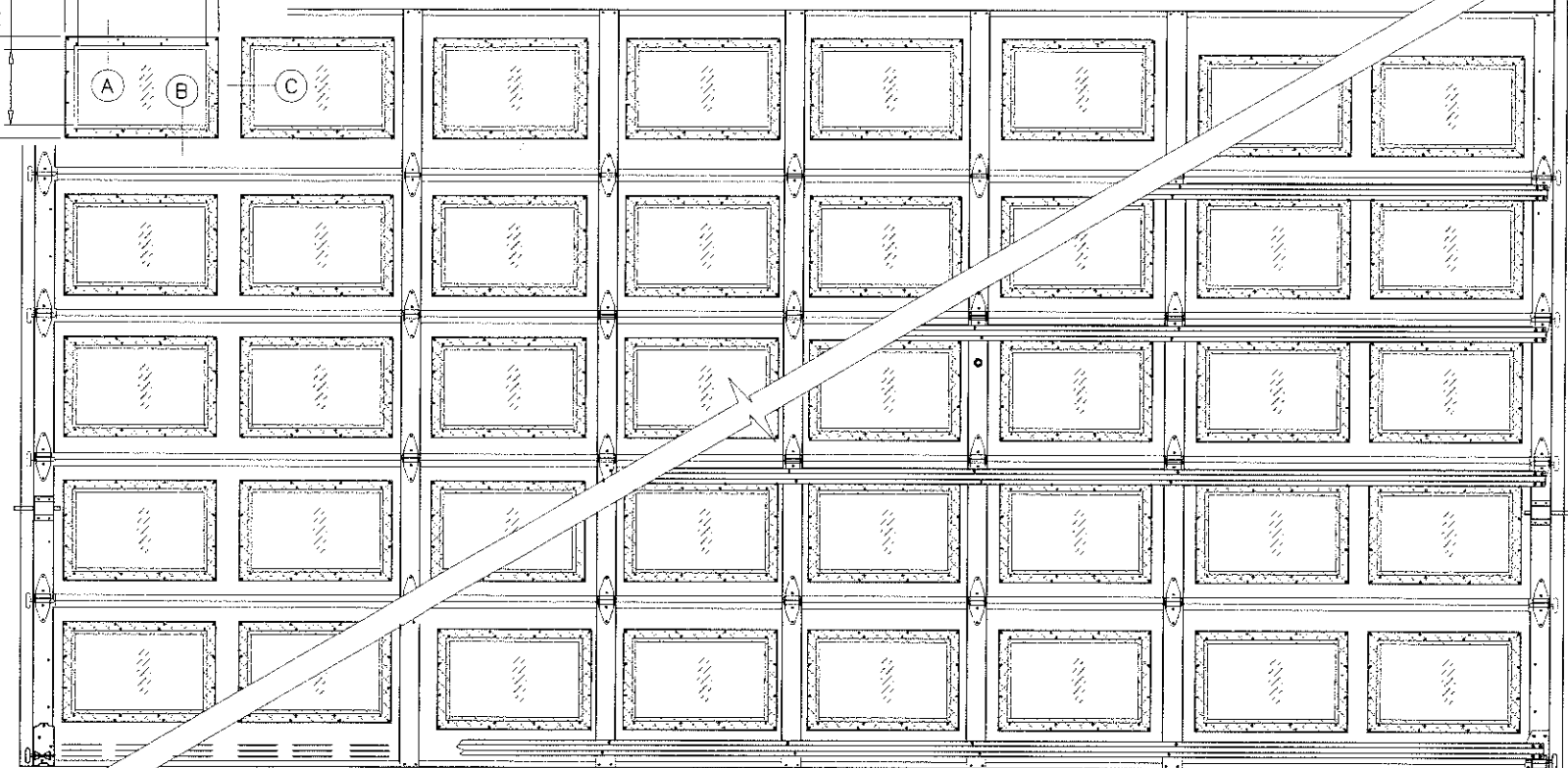
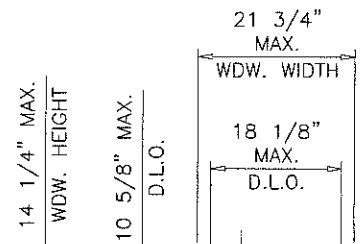

**INSIDE ELEVATION**

RAISED PANEL EMBOSSED DOOR WITH OPTIONAL WINDOWS  
WINDOW LITES CAN BE IN ANY LOCATION IN DOOR SECTION

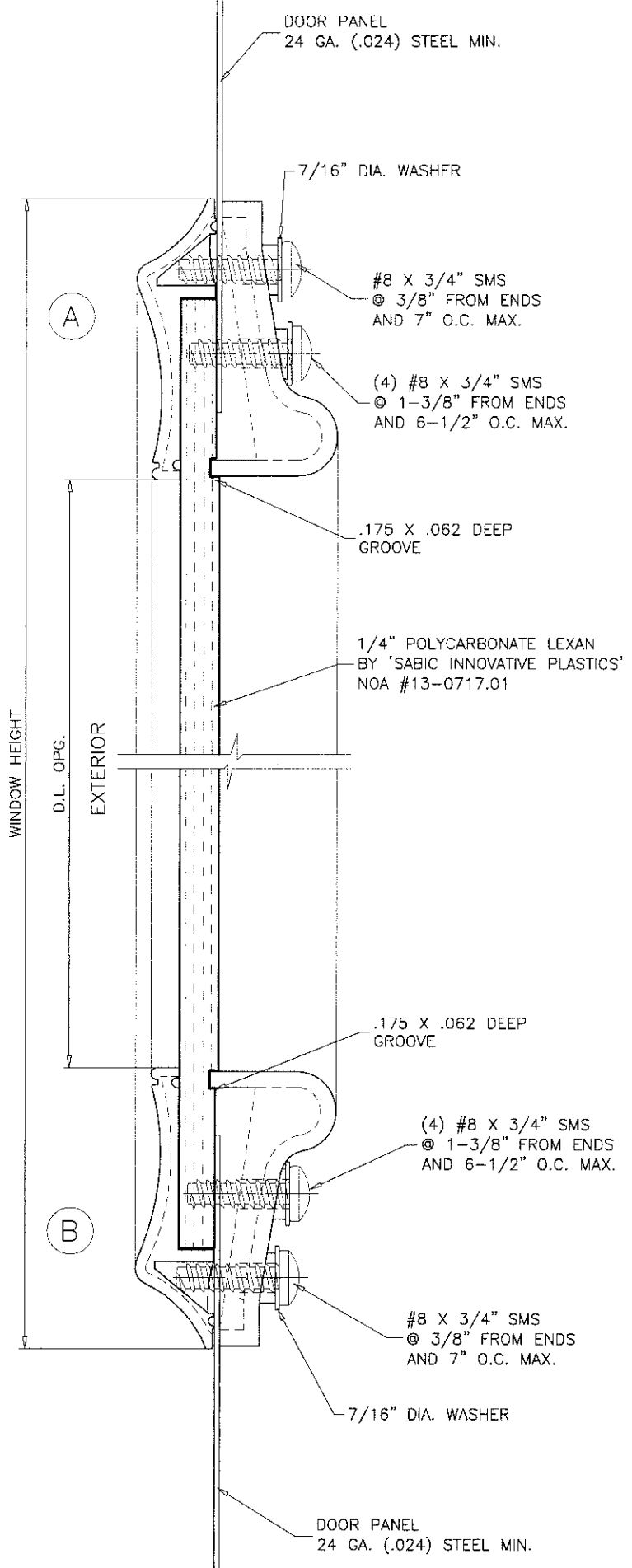
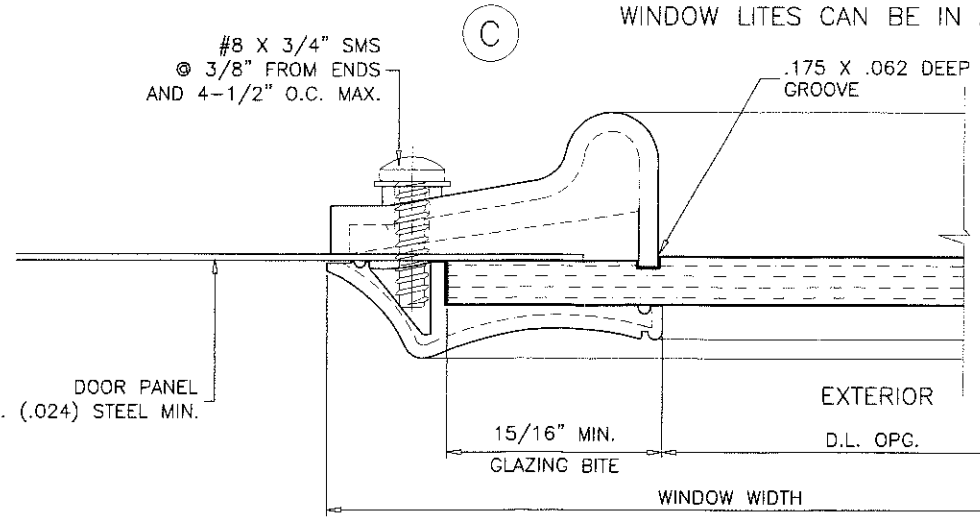

**af c**  
**AL-FAROOQ CORPORATION**  
ENGINEERS & PRODUCT DEVELOPMENT  
1235 S.W. 87 AVE  
MIAMI, FLORIDA 33174  
TEL. (305) 264-8100 FAX. (305) 262-6978  
GARAGE 98-05DAB

24 GA. ROLL FORMED STEEL SECTIONAL GARAGE DR.  
**DAB DOORS INC.**  
12195 N.W. 98 TH. AVE.  
HIALEAH GARDENS, FL. 33018  
TEL. (305) 556 - 6624

no	date	description
H	10.13.11	NO CHANGE THIS SHEET
I	07.21.14	GENERAL REVISION
J	09.16.14	NO CHANGE THIS SHEET
K	11.07.14	REV. PER PER COMMENTS
L	03.05.15	NO CHANGE THIS SHEET

Engr: JAVAD AHMAD  
CIVIL  
FLA. PE # 70592  
C.A.N. 3588  
*[Signature]*  
MAY 30 2015

**PRODUCT RENEWED**  
as complying with the Florida  
Building Code  
Acceptance No 15-0302.01  
Expiration Date 07/21/2020  
By *[Signature]*  
Miami Made Product Control

date: 02-23-98  
scale: -  
dr. by: HAMID  
chk. by:  
drawing no.  
**98-05**  
sheet 6 of 6