



DEPARTMENT OF REGULATORY AND ECONOMIC RESOURCES (RER)
 BOARD AND CODE ADMINISTRATION DIVISION
NOTICE OF ACCEPTANCE (NOA)

MIAMI-DADE COUNTY
 PRODUCT CONTROL SECTION
 11805 SW 26 Street, Room 208
 Miami, Florida 33175-2474
 T (786) 315-2590 F (786) 315-2599
www.miamidade.gov/economy

DAB Door Company, Inc.
 12195 NW 98th Avenue
 Hialeah Gardens, FL 33018

SCOPE:

This NOA is being issued under the applicable rules and regulations governing the use of construction materials. The documentation submitted has been reviewed and accepted by Miami-Dade County RER-Product Control Section to be used in Miami Dade County and other areas where allowed by the Authority Having Jurisdiction (AHJ). This NOA shall not be valid after the expiration date stated below. The Miami-Dade County Product Control Section (In Miami Dade County) and/or the AHJ (in areas other than Miami Dade County) reserve the right to have this product or material tested for quality assurance purposes. If this product or material fails to perform in the accepted manner, the manufacturer will incur the expense of such testing and the AHJ may immediately revoke, modify, or suspend the use of such product or material within their jurisdiction. RER reserves the right to revoke this acceptance, if it is determined by Miami-Dade County Product Control Section that this product or material fails to meet the requirements of the applicable building code.

This product is approved as described herein, and has been designed to comply with the Florida Building Code, including the High Velocity Hurricane Zone.

DESCRIPTION: Hurricane Master® Model 824/811 Steel Sectional Garage Door up to 18'-2" Wide with Window Lite Option (DP +55.0, -64.0 PSF)

APPROVAL DOCUMENT: Drawing No. 99-24, titled "Sectional Garage Door", dated 09/22/1999, with last revision K dated 03/09/2015, sheets 1 through 5 of 5, prepared by Al-Farooq Corporation, signed and sealed by Javad Ahmad, P.E., bearing the Miami-Dade County Product Control revision stamp with the Notice of Acceptance number and expiration date by the Miami-Dade County Product Control Section.

MISSILE IMPACT RATING: Large and Small Missile Impact Resistant

LABELING: A permanent label with the manufacturer's name or logo, manufacturing address, model number, the positive and negative design pressure rating, indicate impact rated if applicable, installation instruction drawing reference number, approval number (NOA), the applicable test standards, and the statement reading 'Miami-Dade County Product Control Approved' is to be located on the door's side track, bottom angle, or inner surface of a panel.

RENEWAL of this NOA shall be considered after a renewal application has been filed and there has been no change in the applicable building code negatively affecting the performance of this product.

TERMINATION of this NOA will occur after the expiration date or if there has been a revision or change in the materials, use, and/or manufacture of the product or process. Misuse of this NOA as an endorsement of any product, for sales, advertising or any other purposes shall automatically terminate this NOA. Failure to comply with any section of this NOA shall be cause for termination and removal of NOA.

ADVERTISEMENT: The NOA number preceded by the words Miami-Dade County, Florida, and followed by the expiration date may be displayed in advertising literature. If any portion of the NOA is displayed, then it shall be done in its entirety.

INSPECTION: A copy of this entire NOA shall be provided to the user by the manufacturer or its distributors and shall be available for inspection at the job site at the request of the Building Official.

This NOA revises NOA # 14-0814.11 and consists of this page 1 and evidence pages E-1 and E-2, as well as approval document mentioned above.

The submitted documentation was reviewed by Carlos M. Utrera, P.E.



[Handwritten Signature]
 06/02/2015

NOA No. 15-0317.05
 Expiration Date: March 10, 2018
 Approval Date: June 11, 2015
 Page 1

NOTICE OF ACCEPTANCE: EVIDENCE SUBMITTED

A. DRAWINGS

1. Drawing No. **99-24**, titled "Sectional Garage Door", dated 09/22/1999, with last revision K dated 03/09/2015, sheets 1 through 5 of 5, prepared by Al-Farooq Corporation, signed and sealed by Javad Ahmad, P.E.

B. TESTS "Submitted under NOA # 09-0324.07"

1. Test reports on 1) Uniform Static Air Pressure Test, Loading per FBC TAS 202-94
2) Large Missile Impact Test per FBC, TAS 201-94
3) Cyclic Wind Pressure Loading per FBC, TAS 203-94
4) Forced Entry Test, per FBC, TAS 202-94
along with marked-up drawings and installation diagram of a DAB 824 24 GA Sectional Residential Garage Door, prepared by Hurricane Engineering & Testing, Inc, Test Reports No. **HETI-08-2133A and B**, dated 06/10/2008, signed and sealed by Candido F. Font, P.E.
2. Test reports on 1) Uniform Static Air Pressure Test, Loading per FBC TAS 202-94
2) Large Missile Impact Test per FBC, TAS 201-94
3) Cyclic Wind Pressure Loading per FBC, TAS 203-94
4) Forced Entry Test, per FBC, TAS 202-94
along with marked-up drawings and installation diagram of a DAB 824 24 GA Sectional Garage Door, prepared by Hurricane Engineering & Testing, Inc, Test Reports No. **HETI-08-2149A/B**, dated 06/27/2008, signed and sealed by Candido F. Font, P.E.

"Submitted under NOA # 08-1106.05"

3. Test report on Tensile Test per ASTM E 8 of the above sectional garage door's skin, prepared by Hurricane Engineering & Testing, Inc, Test Report No. **HETI-08-T139/A**, dated 06/27/2008, signed and sealed by Candido F. Font, P.E.

"Submitted under NOA # 03-0210.04"

4. Test report on Salt Spray (Corrosion) Test per ASTM B 117 of a painted G-40 steel panels, prepared by Celotex Corporation, Test Report No. **258592**, dated 08/17/1998, signed by W. A. Jackson, P.E.

C. CALCULATIONS "Submitted under NOA # 14-0814.11"

1. Anchor verification calculations prepared by Al-Farooq Corporation, dated 09/22/2014 and 07/24/2014, signed and sealed by Javad Ahmad, P.E.
2. Anchor verification calculations and structural analysis prepared by Al-Farooq Corporation, complying with F.B.C 2004/2007, dated 01/20/2009, signed and sealed by Humayoun Farooq, P.E.



06/02/2015

Carlos M. Utrera, P.E.
Product Control Examiner
NOA No. 15-0317.05
Expiration Date: March 10, 2018
Approval Date: June 11, 2015

NOTICE OF ACCEPTANCE: EVIDENCE SUBMITTED

C. CALCULATIONS (Cont.) "Submitted under NOA # 08-1106.05"

3. Anchor verification calculations and structural analysis prepared by Al-Farooq Corporation, complying with F.B.C 2004/2007, dated 08/25/2008, signed and sealed by Humayoun Farooq, P.E.

D. QUALITY ASSURANCE

1. Miami-Dade Department of Regulatory and Economic Resources (RER)

E. MATERIAL CERTIFICATIONS

1. Notice of Acceptance No. **13-0717.01**, issued to SABIC Innovative Plastics, for their Lexan Sheet Products, approved on 11/28/2013 and expiring on 07/17/2018.
2. Notice of Acceptance No. **14-0311.08**, issued to Insulfoam, LLC, for their Insulfoam Expanded Polystyrene Insulation, approved on 08/14/2014 and expiring on 11/29/2017.
3. Notice of Acceptance No. **11-0926.07**, issued to Dyplast Products, LLC, for their Expanded Polystyrene Block Type Insulation, approved on 11/10/2011 and expiring on 01/11/2017.
4. Notice of Acceptance No. **11-0926.06**, issued to Dyplast Products, LLC, for their Dyplast ISO-C1 Polyisocyanurate Insulation, approved on 11/10/2011 and expiring on 01/11/2017.
5. Notice of Acceptance No. **10-1129.04**, issued to Cellofoam North America Inc, for their Expanded Polystyrene Block Insulation, approved on 02/24/2011 and expiring on 02/24/2016.

"Submitted under NOA # 05-0228.02"

6. Test Report on Accelerated Weathering Using Xenon Arc Light Apparatus Test per ASTM G155 of "PVC Extrusion Material", prepared by Hurricane Engineering & Testing, Inc., Report No. **HETI 04-A002**, dated 09/27/2004, signed and sealed by Rafael E. Droz-Seda, P.E.
7. Test Reports on Tensile Test per ASTM D638 of "PVC Extrusion Material", prepared by Hurricane Engineering & Testing Inc., Report No. **HETI 04-T251**, dated 11/29/2004 signed and sealed by I. Ghia, P.E.
8. Test Report on Self-Ignition Temperature Test, Rate of Burn Test and Smoke Density Test of "REHAU non-foam PVC extrusion material", prepared by ETC Laboratories, Report No. **04-761-15019.0**, dated 05/06/2004, signed and sealed by J. L. Doldan, P.E.

F. STATEMENTS "Submitted under NOA # 14-0814.11"

1. Statement letter of code conformance to the 5th edition (2014) FBC and no financial interest issued by Al-Farooq Corporation, dated 05/13/2014, signed and sealed by Javad Ahmad, P.E.

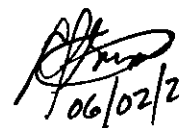
06/02/2015

Carlos M. Utrera, P.E.
Product Control Examiner
NOA No. 15-0317.05
Expiration Date: March 10, 2018
Approval Date: June 11, 2015

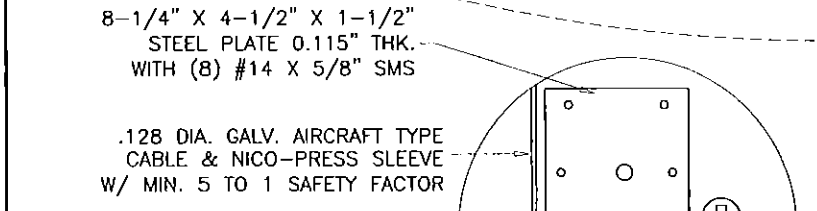
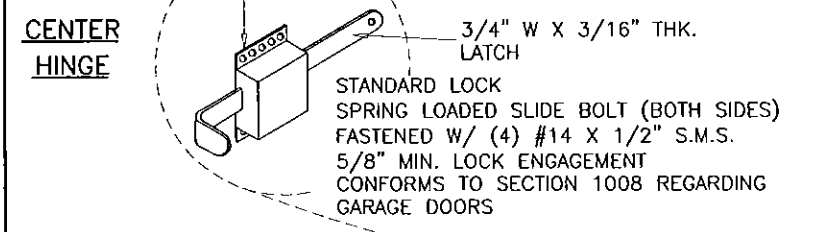
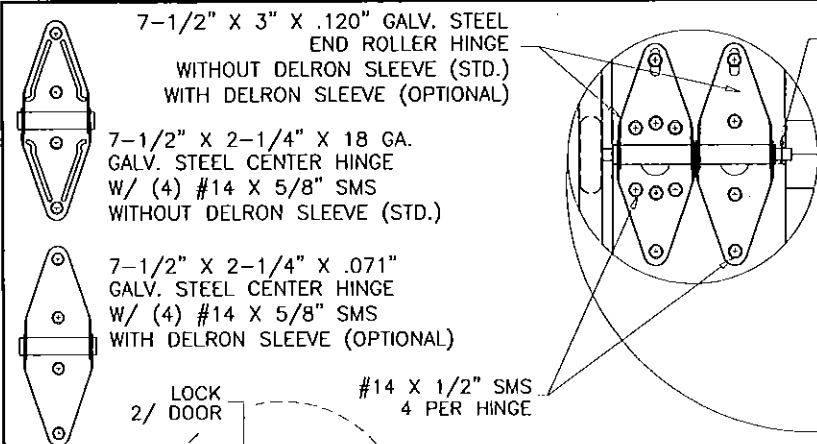

SCHEDULE 'A'

DOOR WIDTHS	# OF CENTER STILES
9'-1" TO 11'-10"	4
12'-0" TO 13'-10"	5
14'-0" TO 15'-10"	6
15'-11" TO 18'-2"	7

DOOR HEIGHT	CONSISTS OF		TOTAL # OF 'U' BARS AT EACH DOOR
6'-6"	2 SECTIONS 18"	2 SECTIONS 21"	10
6'-9"	1 SECTION 18"	3 SECTIONS 21"	
7'	4 SECTIONS 21"	-	
7'-6"	5 SECTIONS 18"	-	12
7'-9"	4 SECTIONS 18"	1 SECTION 21"	
8'	3 SECTIONS 18"	2 SECTIONS 21"	
8'-3"	2 SECTIONS 18"	3 SECTIONS 21"	14
8'-6"	1 SECTION 18"	4 SECTIONS 21"	
8'-9"	5 SECTIONS 21"	-	
9'	6 SECTIONS 18"	-	16
9'-3"	5 SECTIONS 18"	1 SECTION 21"	
9'-6"	4 SECTIONS 18"	2 SECTIONS 21"	
9'-9"	3 SECTIONS 18"	3 SECTIONS 21"	18
10'	2 SECTIONS 18"	4 SECTIONS 21"	
10'-3"	1 SECTION 18"	5 SECTIONS 21"	
10'-6"	6 SECTIONS 21"	-	20
10'-9"	6 SECTIONS 18"	1 SECTION 21"	
11'	5 SECTIONS 18"	2 SECTIONS 21"	
11'-3"	4 SECTIONS 18"	3 SECTIONS 21"	22
11'-6"	3 SECTIONS 18"	4 SECTIONS 21"	
11'-9"	2 SECTIONS 18"	5 SECTIONS 21"	
12'	1 SECTIONS 18"	6 SECTIONS 21"	24
12'-3"	7 SECTIONS 21"	-	
12'-6"	6 SECTIONS 18"	2 SECTIONS 21"	
12'-9"	5 SECTIONS 18"	3 SECTIONS 21"	26
13'	4 SECTIONS 18"	4 SECTIONS 21"	
13'-3"	3 SECTIONS 18"	5 SECTIONS 21"	
13'-6"	2 SECTIONS 18"	6 SECTIONS 21"	28
13'-9"	1 SECTION 18"	7 SECTIONS 21"	
14'	8 SECTIONS 21"	-	
14'-3"	6 SECTIONS 18"	3 SECTIONS 21"	30
14'-6"	5 SECTIONS 18"	4 SECTIONS 21"	
14'-9"	4 SECTIONS 18"	5 SECTIONS 21"	
15'	3 SECTIONS 18"	6 SECTIONS 21"	32
15'-3"	2 SECTIONS 18"	7 SECTIONS 21"	
15'-6"	1 SECTION 18"	8 SECTIONS 21"	
15'-9"	9 SECTIONS 21"	-	34
16'	6 SECTIONS 18"	4 SECTIONS 21"	

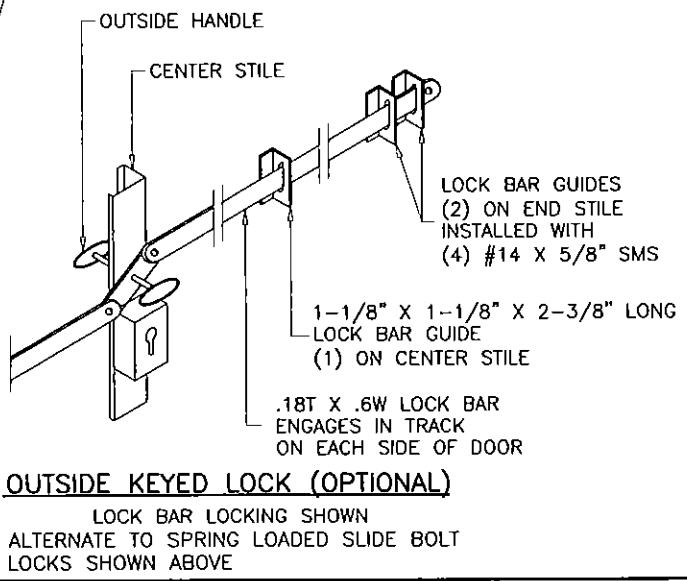
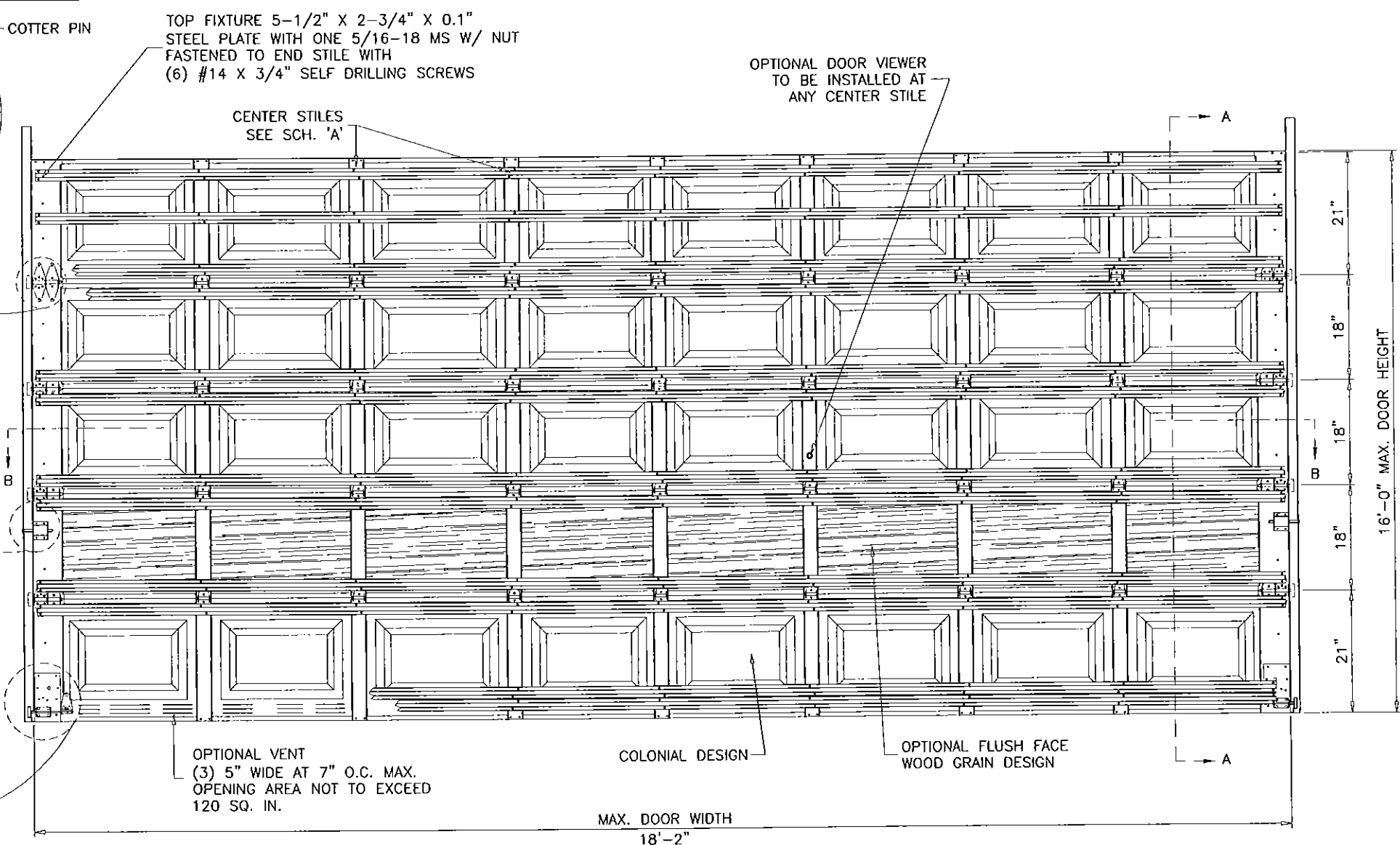
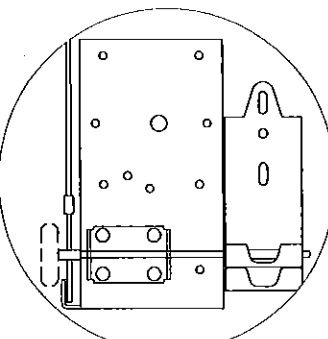
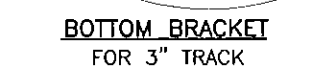

**INSIDE ELEVATION
RAISED PANEL EMBOSSED DOOR**

#14 X 3/4" SELF DRILLING SCREWS MAY BE USED IN LIEU OF #14 X 5/8" SMS

THIS PRODUCT IS RATED FOR LARGE MISSILE IMPACT

DESIGN PRESSURE RATING = + 55.0 PSF
- 64.0 PSF

DAB DOORS INC.
Hurricane Master® Model 824/811
Max. Size 18'-2" X 16'-0" High
With Window Lite Option

GENERAL NOTES

- THIS PRODUCT HAS BEEN DESIGNED AND TESTED TO COMPLY WITH THE REQUIREMENTS OF THE FLORIDA BUILDING CODE (FBC) FIFTH EDITION (2014) INCLUDING HIGH VELOCITY HURRICANE ZONE (HVHZ).
- ANCHORS SHALL BE AS LISTED, SPACED AS SHOWN ON DETAILS. ANCHOR EMBEDMENT TO BASE MATERIAL SHALL BE BEYOND WALL DRESSING OR STUCCO.
- ALL BOLTS, NUTS AND WASHERS SHALL BE ZINC PLATED CARBON STEEL.
- ANCHORING OR LOADING CONDITIONS OTHER THAN THOSE SHOWN IN THESE DETAILS ARE NOT PART OF THIS APPROVAL.
- A LOAD DURATION INCREASE IS USED IN DESIGN OF ANCHORS INTO WOOD ONLY.

DOOR TESTED IN ACCORDANCE WITH THE REQUIREMENTS OF FLORIDA BUILDING CODE, TAS-202, TAS-201 & TAS-203 FOR HVHZ AND ASTM E1886-05/ASTM E1996-09.

Engr: JAVAD AHMAD
CIVIL
FLA. PE # 70592
C.A.N. 3538

PRODUCT REVISED
as complying with the Florida Building Code
Approval No 15-9317.05
Expiring Date 03/10/2018
By: [Signature]
Miami/Dade Product Control

MAR 30 2015

af c
AL-FAROOQ CORPORATION
ENGINEERS & PRODUCT DEVELOPMENT
1235 S.W. 87 AVE
MIAMI, FLORIDA 33174
TEL. (305) 264-8100 FAX. (305) 262-6978
GARAGE/99-24DAB

SECTIONAL GARAGE DOOR
DAB DOORS INC.
12195 N.W. 98 TH. AVE.
HIALEAH GARDENS, FL. 33018
TEL. (305) 556 - 6624

NO	DATE	DESCRIPTION	BY
G	10.13.11	UPDATED TO 2010 FBC	H
H	07.21.14	GENERAL REVISION	I
I	09.16.14	NO CHANGE THIS SHEET	J
J	11.07.14	NO CHANGE THIS SHEET	K
K	03.09.15	NO CHANGE THIS SHEET	

date: 09-22-99
scale: 1/2"=1'-0"
dr. by: HAMID
chk. by:

drawing no.
99-24
sheet 1 of 5

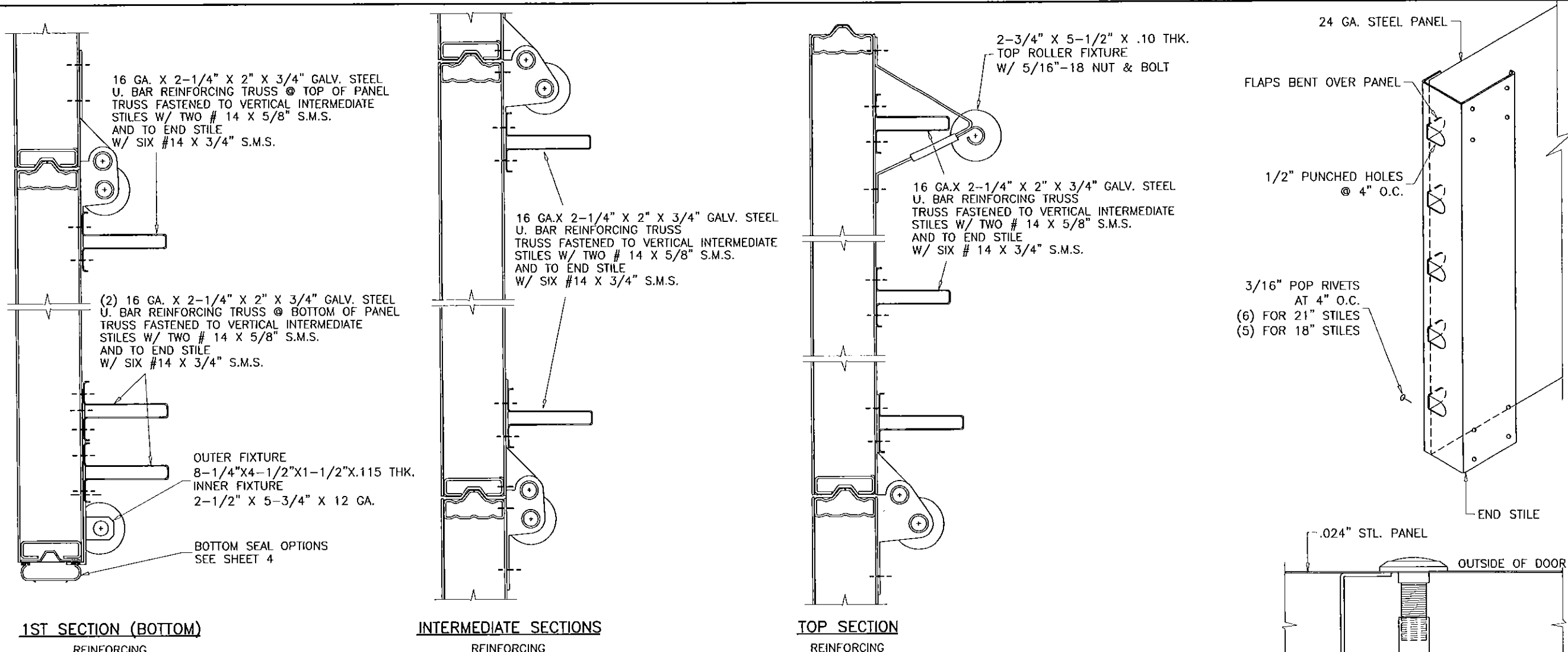

1ST SECTION (BOTTOM)
REINFORCING

INTERMEDIATE SECTIONS
REINFORCING

TOP SECTION
REINFORCING

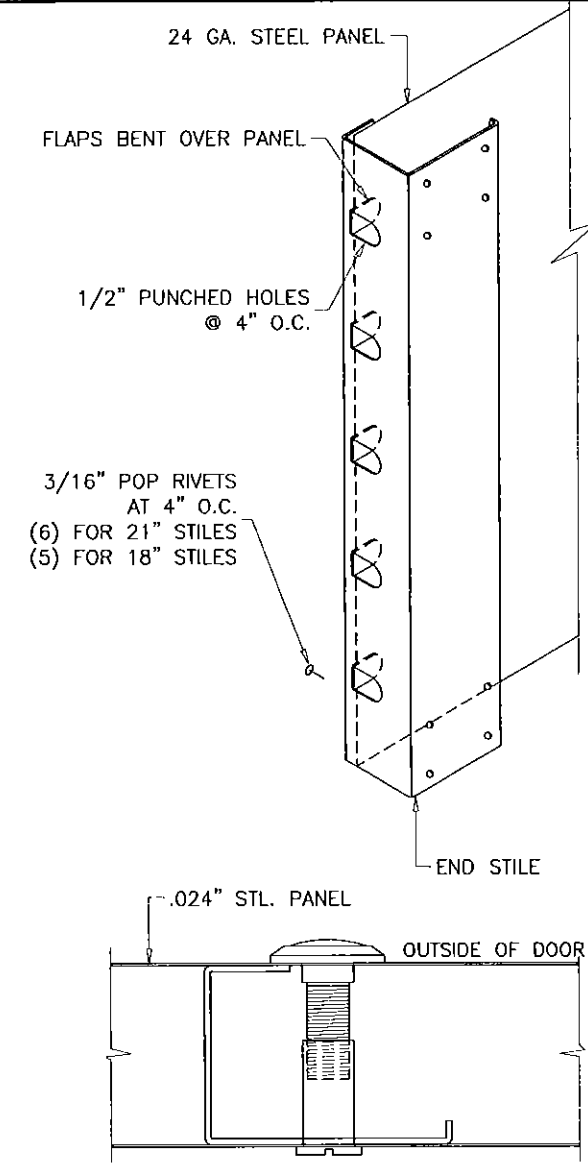

SOLID BRASS DOOR VIEWER
BY 'SCHLAGE SECURITY HARDWARE'
INSTALLED IN 9/16\"/>

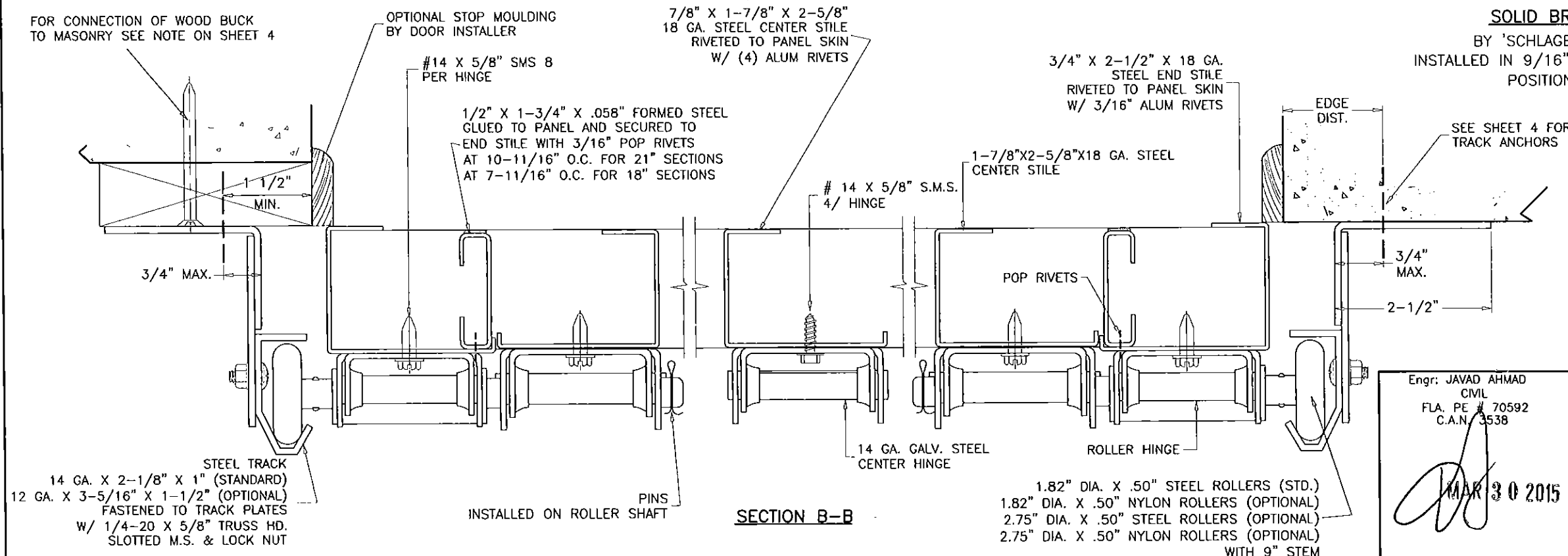

SECTION B-B

Engr: JAVAD AHMAD
CIVIL
FLA. PE # 70592
C.A.N. 3538

MAR 30 2015

PRODUCT REVISED
as complying with the Florida
Building Code
Acceptance No 15-0317-05
Expiration Date 03/10/2018

By *[Signature]*
Miami Trade Product Control

af c

AL-FAROOQ CORPORATION
ENGINEERS & PRODUCT DEVELOPMENT
1235 S.W. 87 AVE
MIAMI, FLORIDA 33174
TEL (305) 264-8100 FAX (305) 262-6978
GARAGE\99-24DAB

SECTIONAL GARAGE DOOR

DAB DOORS INC.
12195 N.W. 98 TH. AVE.
HIALEAH GARDENS, FL. 33018
TEL (305) 556 - 6624

no	date	description
G	10.13.11	NO CHANGE THIS SHEET
H	07.21.14	GENERAL REVISION
I	09.15.14	NO CHANGE THIS SHEET
J	11.07.14	NO CHANGE THIS SHEET
K	03.09.15	BOTTOM SEAL OPTION ADDED

revisions:

date: 09-22-99
scale: -
dr. by: HAMID
chk. by:

drawing no.
99-24

sheet 2 of 5

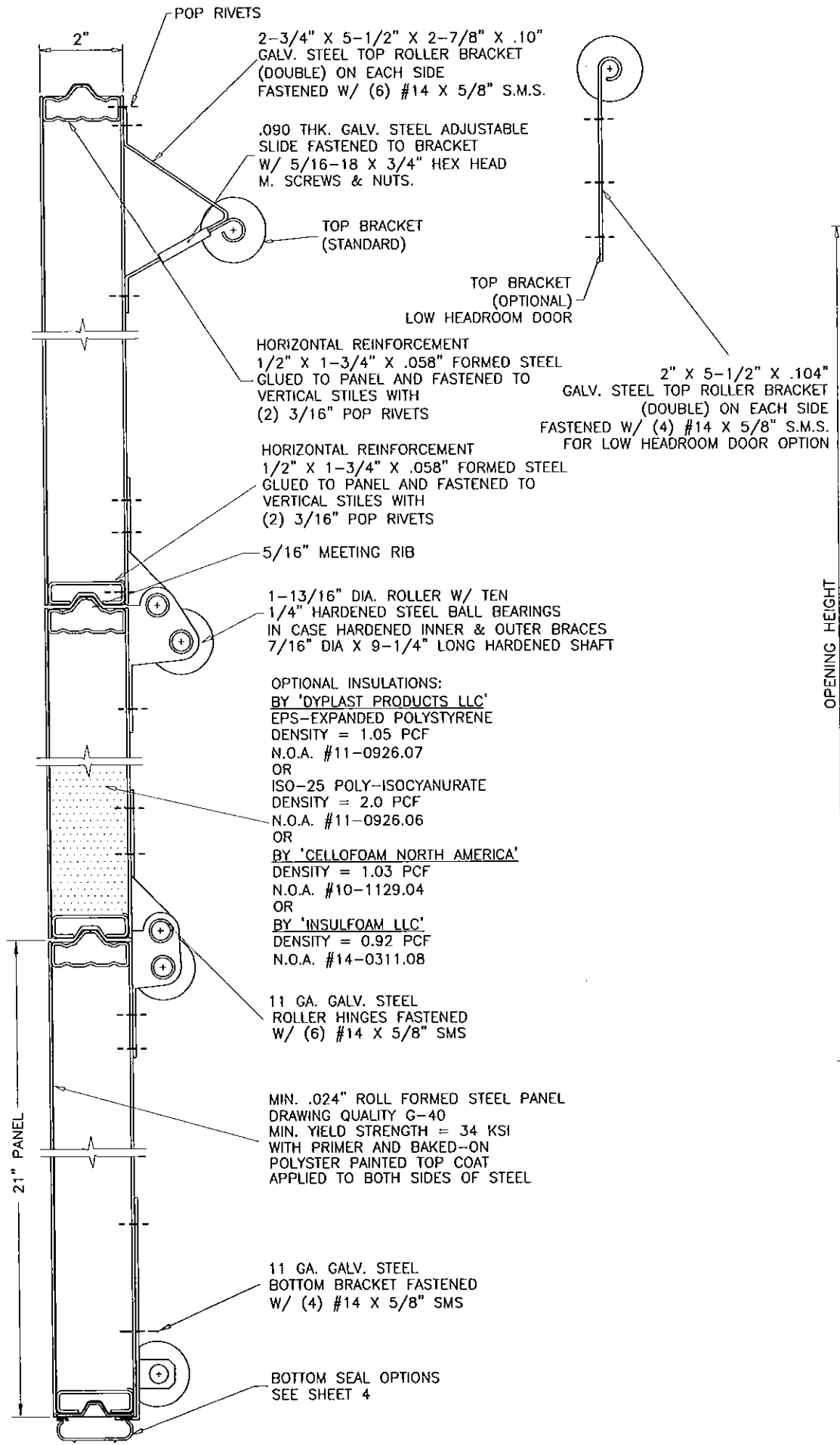

SECTION A-A
SEE SHEET 2 FOR LOCATION OF REINFORCING TRUSSES

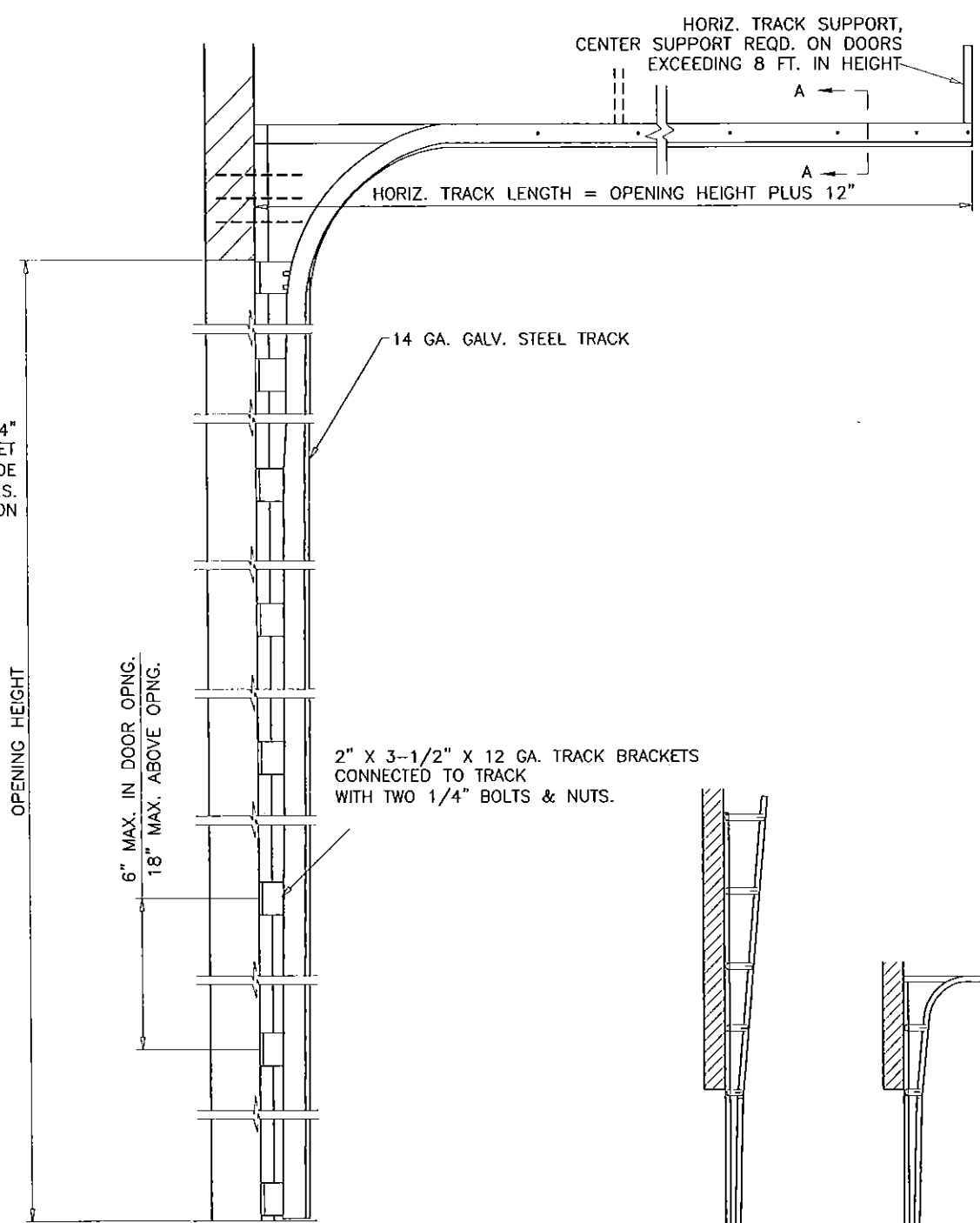

TRACK CONFIGURATION

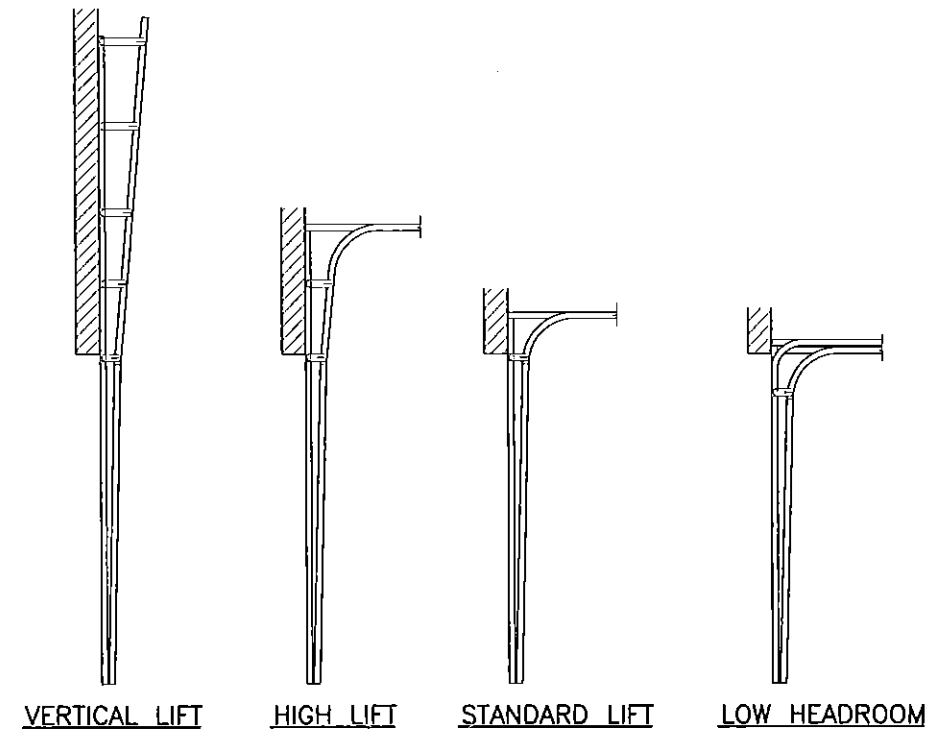
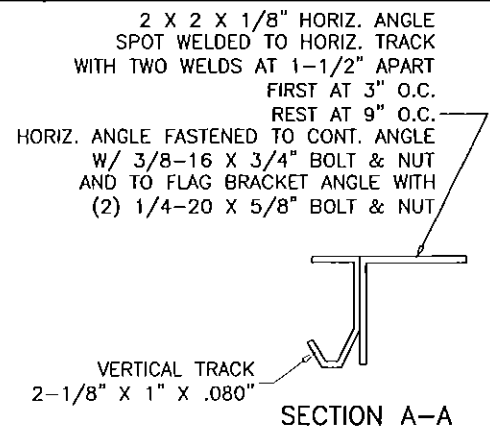

AVAILABLE TRACK OPTIONS

Engr: JAVAD AHMAD
CIVIL
FLA. PE # 70592
C.A.N. 3538
[Signature]
MAR 20 2015

PRODUCT REVISED
as complying with the Florida Building Code
Acceptance No 15-0317.05
Expiration Date 03/10/2018
By *[Signature]*
Miami Dade Product Control

af c
AL-FAROOQ CORPORATION
ENGINEERS & PRODUCT DEVELOPMENT
1235 S.W. 87 AVE
MIAMI, FLORIDA 33174
TEL. (305) 264-8100 FAX. (305) 262-6978
GARAGE\99-24DAB

SECTIONAL GARAGE DOOR
DAB DOORS INC.
12195 N.W. 98 TH. AVE.
HIALEAH GARDENS, FL. 33018
TEL. (305) 556 - 6624

no	date	description	by
G	10.13.11	NO CHANGE THIS SHEET	
H	07.21.14	GENERAL REVISION	
I	09.16.14	FOAM NOA REV.	
J	11.07.14	NO CHANGE THIS SHEET	
K	03.09.15	BOTTOM SEAL OPTION ADDED	

date: 09-22-99
scale: -
dr. by: HAMID
chk. by:

drawing no.
99-24
sheet 3 of 5

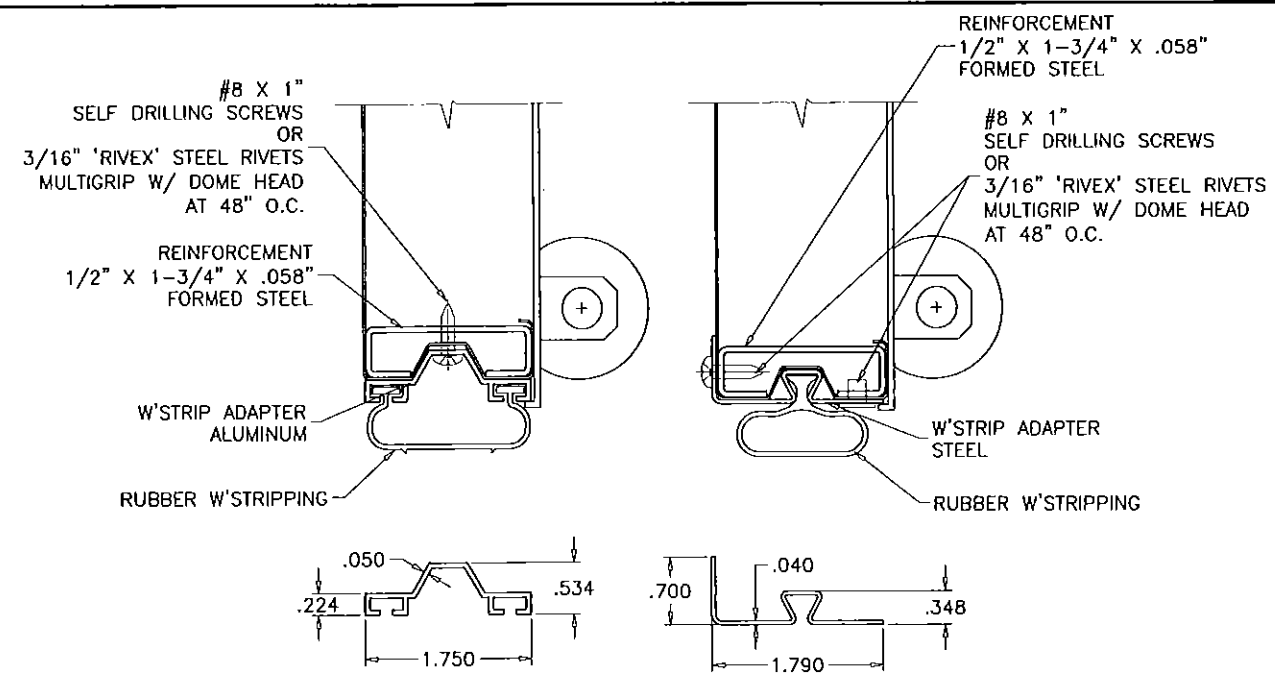
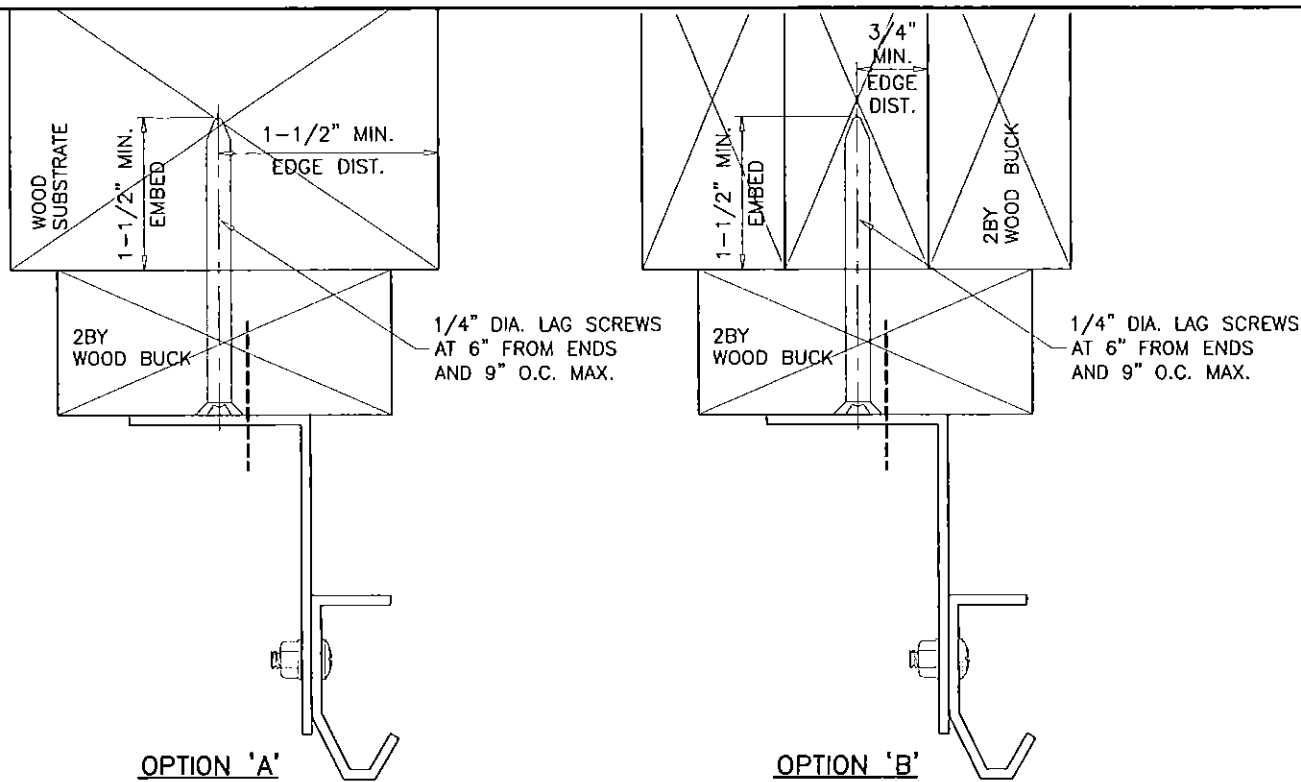

BOTTOM SEAL OPTIONS

WOOD BUCK CONNECTION TO WOOD SUBSTRATE (WOOD SPECIFIC GRAVITY SG=0.55 MIN.)

THE INSTALLATION METHODS SHOWN ABOVE SHOWS 2X6 SYP WOOD BUCK ATTACHMENT TO WOOD STRUCTURES. IF THESE METHODS ARE FOLLOWED NO ADDITIONAL CALCULATIONS/DESIGN WILL BE REQUIRED FOR DESIGN OF GARAGE DOOR ANCHORAGE. FOR DOOR REPLACEMENT APPLICATIONS WITH NO ENGINEER OF RECORD, INSTALLATION MAY BE VERIFIED AND APPROVED BY THE BUILDING OFFICIAL UPON INSPECTION.

WOOD BUCK CONNECTION TO MASONRY

PRESSURE TREATED 2X6 SYP WOOD JAMBS WHICH SHALL BE ANCHORED TO GROUTED REINFORCED MASONRY BLOCK WALL OR CONC. COLUMN WITH

1/4" ULTRACON BY 'ELCO' WITH SPACING OF 6" O.C. INTO GROUT FILLED BLOCK WALL, WITH 2-1/4" MIN. EMBED 7" O.C. INTO 3000 PSI CONCRETE, WITH 1-3/4" MIN. EMBED 2-1/2" MIN. EDGE DISTANCE

1/4" TAPPER BY 'POWERS' WITH SPACING OF 4" O.C. INTO GROUT FILLED BLOCK WALL, WITH 1-1/2" MIN. EMBED 5" O.C. INTO 3000 PSI CONCRETE, WITH 1-3/4" MIN. EMBED 3" MIN. EDGE DISTANCE

3/8" CONFLX BY 'ELCO' OR 3/8" LDT BY 'ITW' WITH SPACING OF 11" O.C. INTO 3000 PSI CONCRETE, WITH 2-1/2" MIN. EMBED 3" MIN. EDGE DISTANCE

3/8" HLC SLEEVE BY 'HILTI' WITH SPACING OF 7" O.C. INTO 3000 PSI CONCRETE, WITH 1-1/4" MIN. EMBED AND 2-1/2" MIN. EDGE DISTANCE

PREPARATION OF JAMBS BY OTHERS

FOR NEW CONSTRUCTION ENGINEER OF RECORD OR ARCHITECT TO VERIFY ADEQUACY OF SUPPORTING STRUCTURE TO SUPPORT LOADS IMPOSED BY DOOR SYSTEM. FOR DOOR REPLACEMENT IN RETROFIT BUILDINGS WITH NO ENGINEER OF RECORD, DOOR INSTALLATION MAY BE REVIEWED AND APPROVED BY BUILDING OFFICIAL UPON INSPECTION.

MAXIMUM EXTERIOR(+) LOAD PER JAMB = (18.16' X 55 PSF)/2 = 499.4 Lbs per Ft.
MAXIMUM INTERIOR(-) LOAD PER JAMB = (18.16' X 64 PSF)/2 = 581.1 Lbs per Ft.

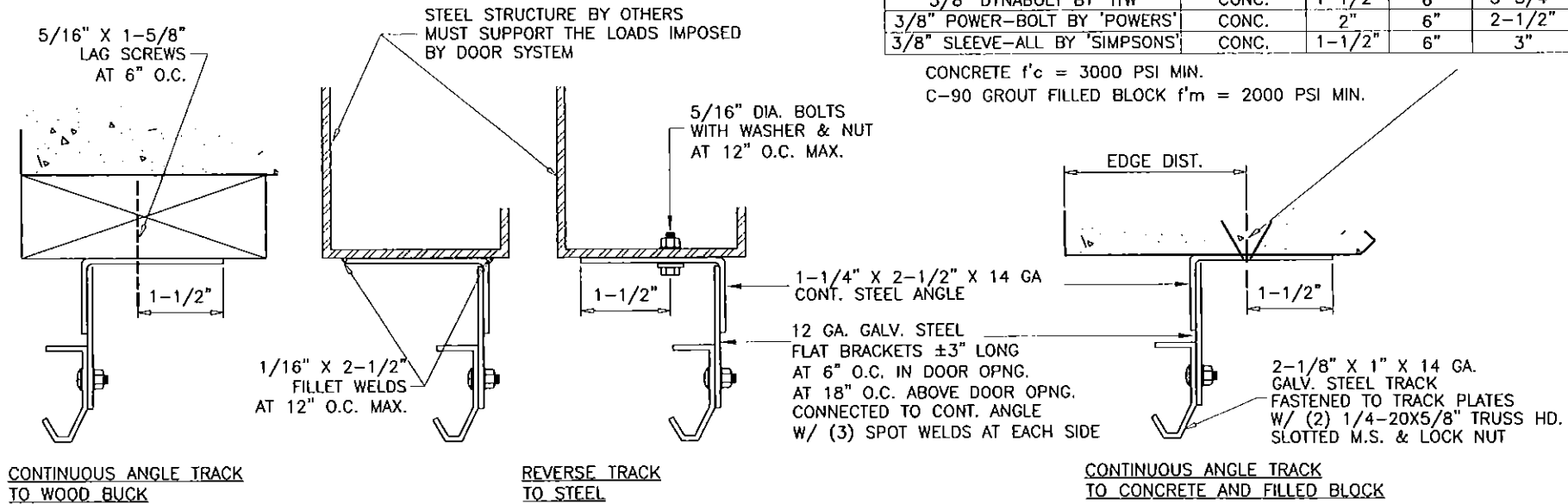

ALTERNATE TRACK INSTALLATION

ANCHOR SPACING				
ANCHORS	STRUCTURE	EMBED	SPACING	EDGE DIST.
3/8" HLC SLEEVE BY 'HILTI'	CONC.	1-1/4"	6"	2-1/2"
3/8" CONFLX BY 'ELCO'	FILLED BLOCK	2"	8"	3-3/4"
3/8" DYNABOLT BY 'ITW'	CONC.	1-1/2"	6"	3-3/4"
3/8" POWER-BOLT BY 'POWERS'	CONC.	2"	6"	2-1/2"
3/8" SLEEVE-ALL BY 'SIMPSONS'	CONC.	1-1/2"	6"	3"

CONCRETE f'c = 3000 PSI MIN.
C-90 GROUT FILLED BLOCK f'm = 2000 PSI MIN.

afC
AL-FAROOQ CORPORATION
ENGINEERS & PRODUCT DEVELOPMENT
1235 S.W. 87 AVE
MIAMI, FLORIDA 33174
TEL. (305) 264-8400 FAX. (305) 262-6978
GARAGE/99-24DAB

SECTIONAL GARAGE DOOR
DAB DOORS INC.
12195 N.W. 98 TH. AVE.
HIALEAH GARDENS, FL. 33018
TEL. (305) 556 - 8624

no.	date	description
G	10.13.11	NO CHANGE THIS SHEET
H	07.21.14	GENERAL REVISION
I	09.15.14	ANCHORS REVISED
J	11.07.14	REV. PER REC COMMENTS
K	03.09.15	BOTTOM SEAL OPTION ADDED

Engr: JAVAD AHMAD
CIVIL
FLA. PE # 70592
C.A.N. 3538
MAR 20 2015

PRODUCT REVISED
as complying with the Florida
Building Code
Acceptance No. 15-0317.05
Expiration Date 03/10/2018
By: *[Signature]*
Miami Dade Product Control

date: 09-22-99
scale: -
dr. by: HAMID
chk. by:
drawing no. 99-24
sheet 4 of 5

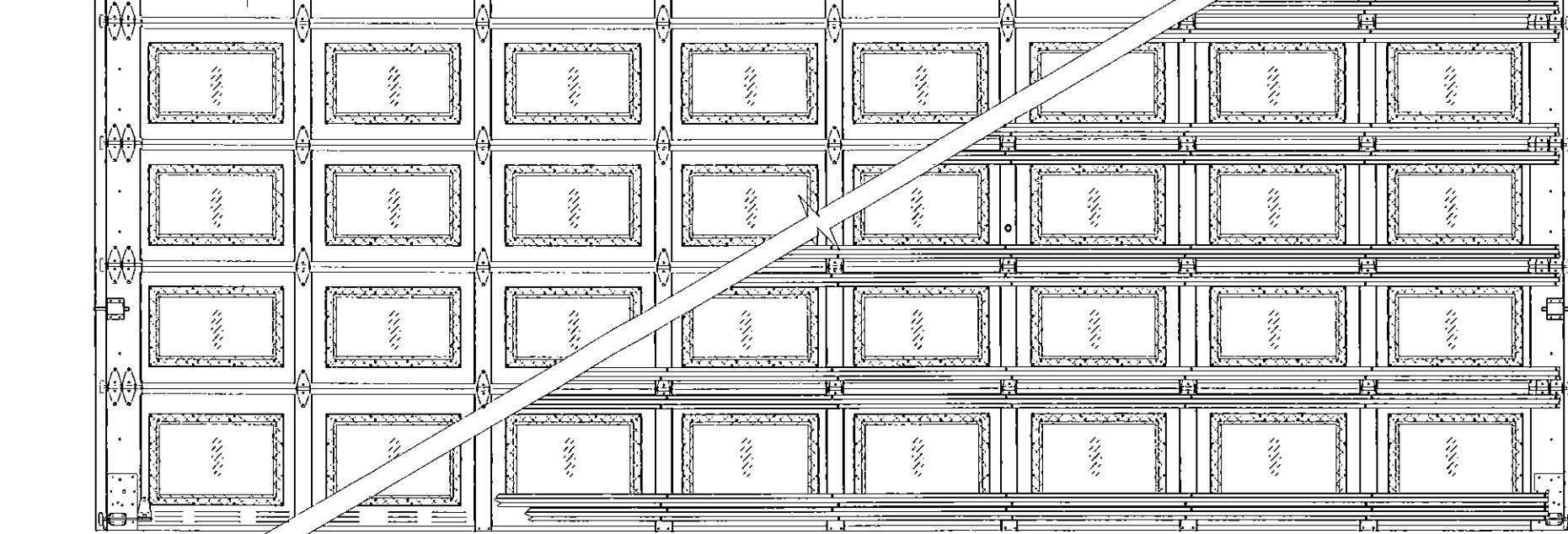
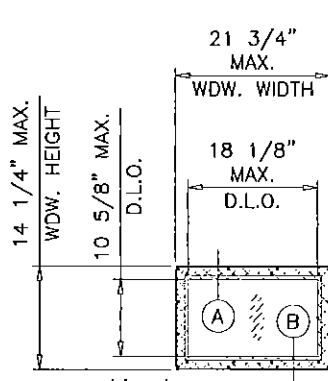
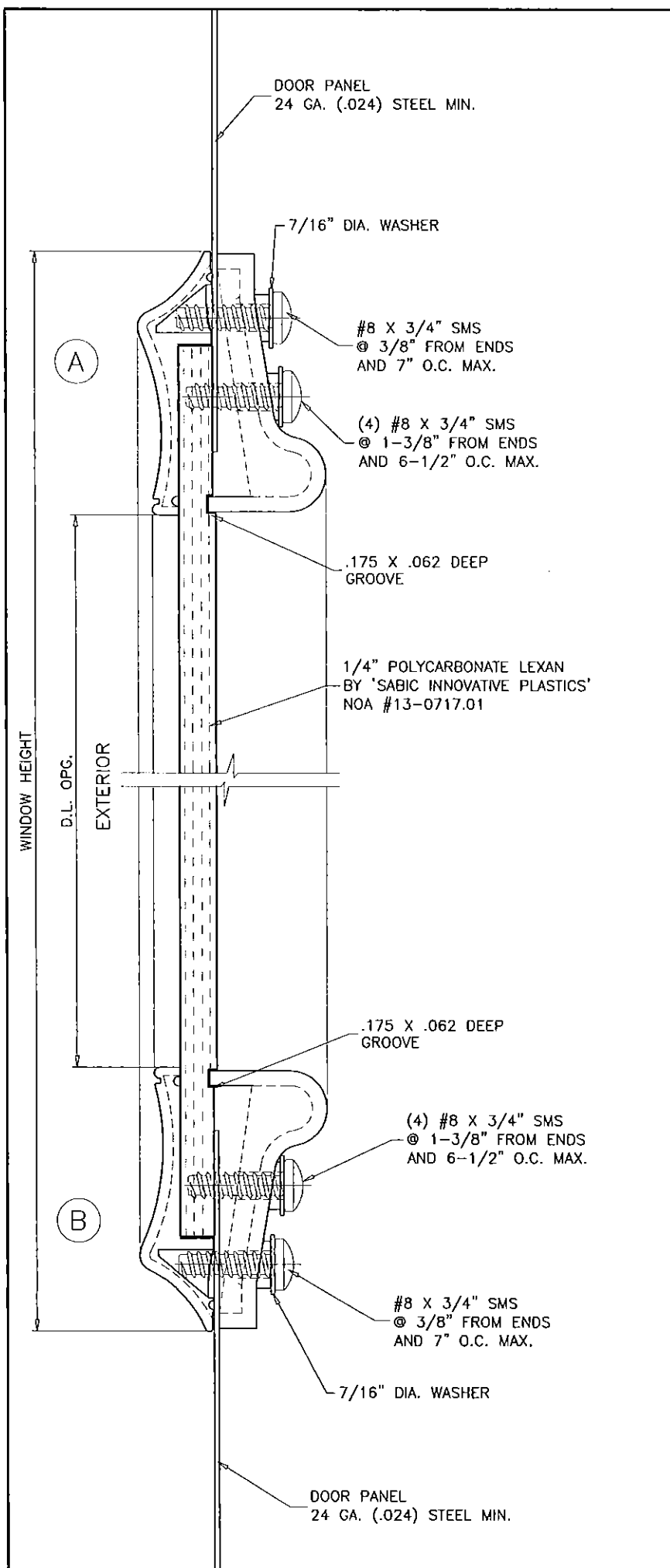

* PLASTIC COMPLIES WITH CHAPTER 26 OF FBC SEE EVIDENCE PAGE

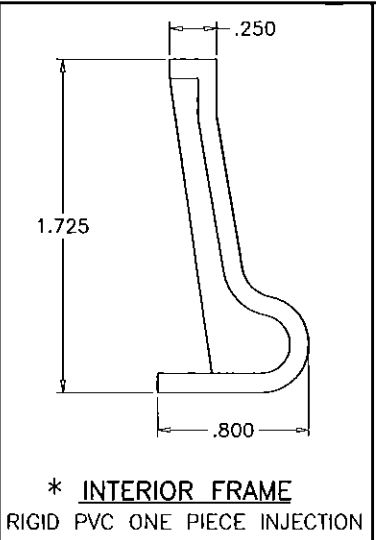
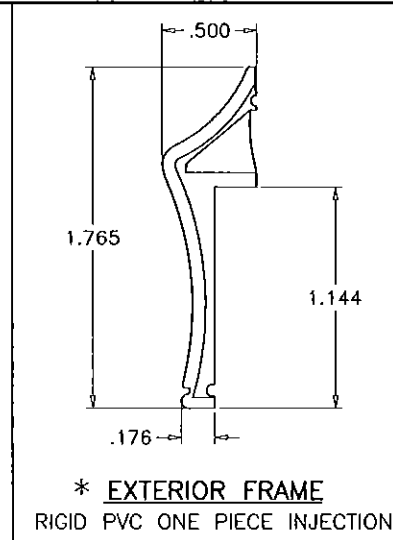

INSIDE ELEVATION
RAISED PANEL EMBOSSED DOOR WITH OPTIONAL WINDOWS
WINDOW LITES CAN BE IN ANY LOCATION IN DOOR SECTION

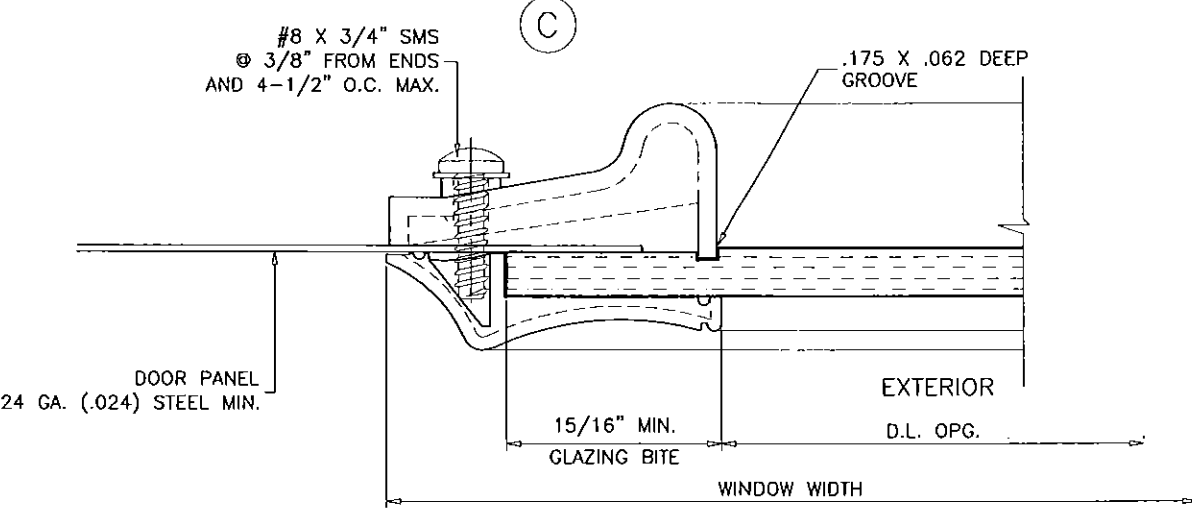

Engr: JAVAD AHMAD
CIVIL
FLA. PE # 70592
C.A.N. 3538

MAR 30 2015

PRODUCT REVISED
as complying with the Florida Building Code
Acceptance No 15-0317.05
Expiration Date 03/10/2018
By: *[Signature]*
Miami Dade Product Control

af c
AL-FAROOQ CORPORATION
ENGINEERS & PRODUCT DEVELOPMENT
1235 S.W. 87 AVE
MIAMI, FLORIDA 33174
TEL. (305) 264-8100 FAX. (305) 262-6978
GARAGE\99-24DAB

SECTIONAL GARAGE DOOR
DAB DOORS INC.
12195 N.W. 98 TH. AVE.
HIALEAH GARDENS, FL. 33018
TEL. (305) 556 - 6624

revisions:	no	date	description	by
	G	10.13.11	NO CHANGE THIS SHEET	
	H	07.21.14	GENERAL REVISION	
	I	09.16.14	NO CHANGE THIS SHEET	
	J	11.07.14	REV. PER RER COMMENTS	
	K	03.09.15	NO CHANGE THIS SHEET	

date: 09-22-99
scale: -
dr. by: HAMID
chk. by:

drawing no.
99-24
sheet 5 of 5