



DEPARTMENT OF REGULATORY AND ECONOMIC RESOURCES (RER)  
BOARD AND CODE ADMINISTRATION DIVISION

**NOTICE OF ACCEPTANCE (NOA)**

MIAMI-DADE COUNTY  
PRODUCT CONTROL SECTION  
11805 SW 26 Street, Room 208  
T (786) 315-2590 F (786) 315-2599  
[www.miamidade.gov/economy](http://www.miamidade.gov/economy)

Eco Window Systems, LLC  
9114 NW 106 Street  
Medley, FL 33178

**SCOPE:**

This NOA is being issued under the applicable rules and regulations governing the use of construction materials. The documentation submitted has been reviewed and accepted by Miami-Dade County RER-Product Control Section to be used in Miami-Dade County and other areas where allowed by the Authority Having Jurisdiction (AHJ).

This NOA shall not be valid after the expiration date stated below. The Miami-Dade County Product Control Section (In Miami-Dade County) and/ or the AHJ (in areas other than Miami-Dade County) reserve the right to have this product or material tested for quality assurance purposes. If this product or material fails to perform in the accepted manner, the manufacturer will incur the expense of such testing and the AHJ may immediately revoke, modify, or suspend the use of such product or material within their jurisdiction. RER reserves the right to revoke this acceptance, if it is determined by Miami-Dade County Product Control Section that this product or material fails to meet the requirements of the applicable building code.

This product is approved as described herein, and has been designed to comply with the Florida Building Code, including the High Velocity Hurricane Zone.

**DESCRIPTION: Series "Eco-Guard 550" Aluminum Fixed Window - L.M.I.**

**APPROVAL DOCUMENT:** Drawing No. W11-10, titled "S-550 Aluminum Fixed Window (L.M.I.)", sheets 1 through 6 of 6, dated 02/28/11, with revision D dated 06/23/15, prepared by Al-Farooq Corporation, signed and sealed by Javad Ahmad, P.E., bearing the Miami-Dade County Product Control Revision stamp with the Notice of Acceptance number and expiration date by the Miami-Dade County Product Control Section.

**MISSILE IMPACT RATING: Large and Small Missile Impact Resistant**

**LABELING:** Each unit shall bear a permanent label with the manufacturer's name or logo, city, state, series, and following statement: "Miami-Dade County Product Control Approved", unless otherwise noted herein.

**RENEWAL** of this NOA shall be considered after a renewal application has been filed and there has been no change in the applicable building code negatively affecting the performance of this product.

**TERMINATION** of this NOA will occur after the expiration date or if there has been a revision or change in the materials, use, and/ or manufacture of the product or process. Misuse of this NOA as an endorsement of any product, for sales, advertising or any other purposes shall automatically terminate this NOA. Failure to comply with any section of this NOA shall be cause for termination and removal of NOA.

**ADVERTISEMENT:** The NOA number preceded by the words Miami-Dade County, Florida, and followed by the expiration date may be displayed in advertising literature. If any portion of the NOA is displayed, then it shall be done in its entirety.

**INSPECTION:** A copy of this entire NOA shall be provided to the user by the manufacturer or its distributors and shall be available for inspection at the job site at the request of the Building Official.

This NOA revises and renews NOA No. 13-0206.08 and consists of this page 1 and evidence pages E-1 and E-2, as well as approval document mentioned above.

The submitted documentation was reviewed by Manuel Perez, P.E.



*MP*  
6/26/15

NOA No. 15-0406.11  
Expiration Date: May 05, 2021  
Approval Date: July 02, 2015  
Page 1

NOTICE OF ACCEPTANCE: EVIDENCE SUBMITTED

**A. DRAWINGS**

1. Manufacturer's die drawings and sections.  
*(Submitted under NOA No. 11-0309.07)*
2. Drawing No. **W11-10**, titled "S-550 Aluminum Fixed Window (L.M.I.)", sheets 1 through 6 of 6, dated 02/28/11, with revision **D** dated 06/23/15, prepared by Al-Farooq Corporation, signed and sealed by Javad Ahmad, P.E.

**B. TESTS**

1. Test reports on: 1) Air Infiltration Test, per FBC, TAS 202-94  
2) Uniform Static Air Pressure Test, Loading per FBC TAS 202-94  
3) Water Resistance Test, per FBC, TAS 202-94  
along with marked-up drawings and installation diagram of an aluminum fixed window, prepared by Hurricane Engineering and Testing, Inc., Test Report No. **HETI-10-3145**, dated 12/29/10, signed and sealed by Candido F. Font, P.E.  
*(Submitted under NOA No. 11-0309.07)*
2. Test reports on: 1) Large Missile Impact Test per FBC, TAS 201-94  
2) Cyclic Wind Pressure Loading per FBC, TAS 203-94  
along with marked-up drawings and installation diagram of an aluminum fixed window, prepared by Hurricane Engineering and Testing, Inc., Test Reports No. **HETI-10-3146**, **HETI-10-3147** and **HETI-10-3149**, all dated 12/29/10, signed and sealed by Candido F. Font, P.E.  
*(Submitted under NOA No. 11-0309.07)*
3. Test reports on: 1) Uniform Static Air Pressure Test, Loading per FBC TAS 202-94  
along with marked-up drawings and installation diagram of an aluminum fixed window, prepared by Hurricane Engineering and Testing, Inc., Test Report No. **HETI-10-3148**, dated 12/29/10, signed and sealed by Candido F. Font, P.E.  
*(Submitted under NOA No. 11-0309.07)*

**C. CALCULATIONS**

1. Anchor verification calculations and structural analysis, complying with **FBC 5<sup>th</sup> Edition (2014)**, prepared by Al-Farooq Corporation, dated 03/27/15 and 06/23/15, signed and sealed by Javad Ahmad, P.E.
2. Glazing complies with **ASTM E1300-09**

**D. QUALITY ASSURANCE**

1. Miami-Dade Department of Regulatory and Economic Resources (RER)



Manuel Perez, P.E.  
Product Control Examiner  
NOA No. 15-0406.11

Expiration Date: May 05, 2021

Approval Date: July 02, 2015

Eco Window Systems, LLC.

NOTICE OF ACCEPTANCE: EVIDENCE SUBMITTED

**E. MATERIAL CERTIFICATIONS**

1. Notice of Acceptance No. **14-0916.10** issued to **Kuraray America, Inc.** for their “**Kuraray Butacite® PVB Glass Interlayer**” dated 04/25/15, expiring on 12/11/16.

**F. STATEMENTS**

1. Statement letter of conformance, complying with **FBC-5<sup>th</sup> Edition (2014)**, and of no financial interest, dated March 17, 2015, issued by Al-Farooq Corporation, signed and sealed by Javad Ahmad, P.E.
2. Laboratory compliance letters for Test Reports No. **HETI-10-3145, HETI-10-3146, HETI-10-3147, HETI-10-3148 and HETI-10-3149**, all issued by Hurricane Engineering and Testing, Inc., dated 12/29/10, signed and sealed by Candido F. Font, P.E.  
*(Submitted under NOA No. 11-0309.07)*

**G. OTHERS**

1. Notice of Acceptance No. **13-0206.08**, issued to Eco Window Systems, LLC for their Series “Eco-Guard 550” Aluminum Fixed Window - L.M.I., approved on 05/02/13 and expiring on 05/05/16.



Manuel Pérez, P.E.  
Product Control Examiner  
NOA No. 15-0406.11

Expiration Date: May 05, 2021  
Approval Date: July 02, 2015

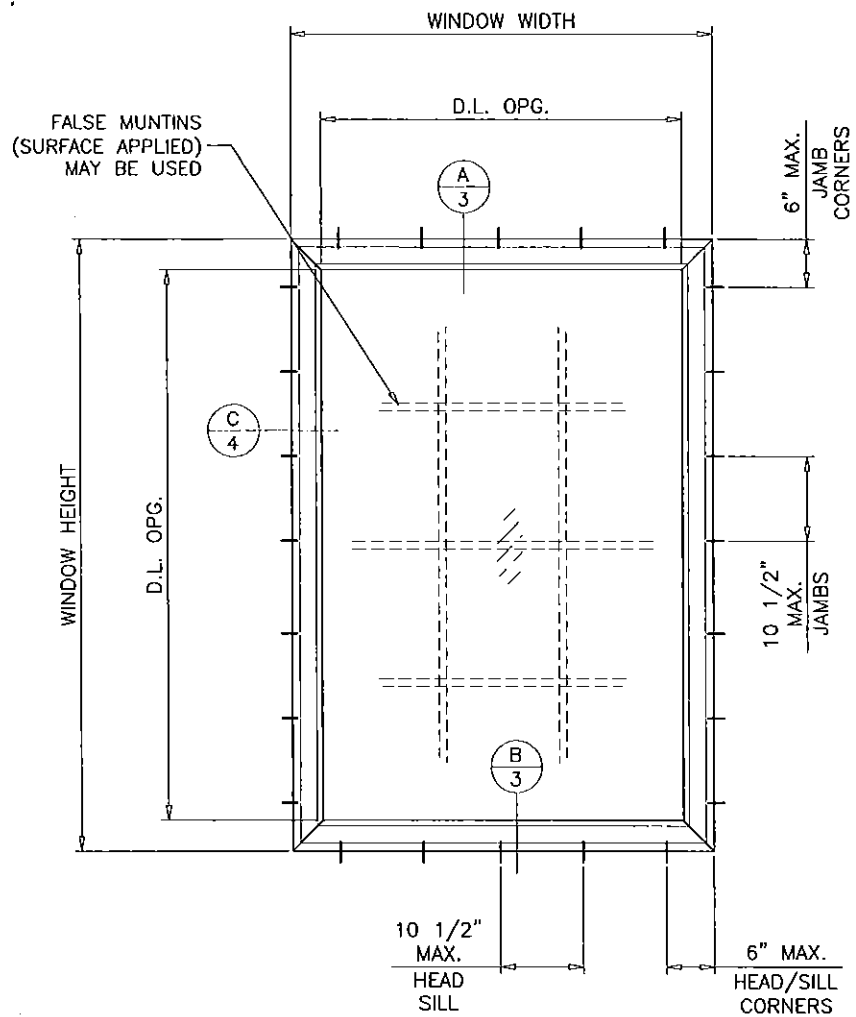

TYPICAL ELEVATION

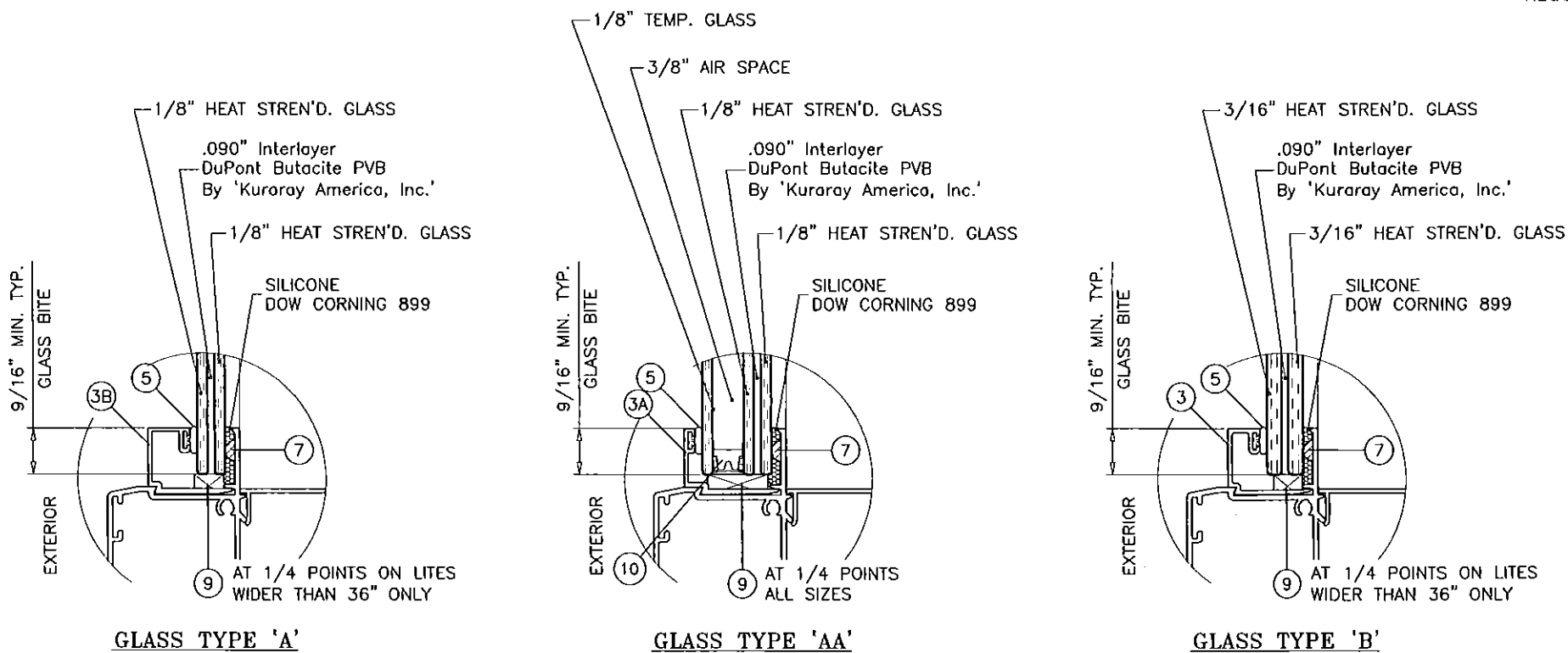

GLAZING OPTIONS

THESE WINDOWS ARE RATED FOR LARGE & SMALL MISSILE IMPACT. SHUTTERS ARE NOT REQUIRED.

**ECO-GUARD SERIES-550  
ALUMINUM FIXED WINDOW**

DESIGN LOAD RATINGS FOR THESE WINDOWS TO BE AS PER CHARTS SHOWN ON SHEETS 2.

APPROVAL APPLIES TO SINGLE UNITS OR SIDE BY SIDE COMBINATIONS OF FIX./FIX. OR FIXED WITH OTHER WINDOW TYPES IN MODULES OF TWO OR MORE WINDOWS USING MIAMI-DADE COUNTY APPROVED MULLIONS IN BETWEEN. LOWER DESIGN PRESSURE FROM WINDOWS OR MULLION APPROVAL WILL APPLY TO ENTIRE SYSTEM.

THIS PRODUCT HAS BEEN DESIGNED AND TESTED TO COMPLY WITH THE REQUIREMENTS OF THE FLORIDA BUILDING CODE INCLUDING HIGH VELOCITY HURRICANE ZONE (HVHZ).

WOOD BUCKS BY OTHERS, MUST BE ANCHORED PROPERLY TO TRANSFER LOADS TO THE STRUCTURE.

ANCHORS SHALL BE AS LISTED, SPACED AS SHOWN ON DETAILS, ANCHORS EMBEDMENT TO BASE MATERIAL SHALL BE BEYOND WALL DRESSING OR STUCCO.

ANCHORING OR LOADING CONDITIONS NOT SHOWN IN THESE DETAILS ARE NOT PART OF THIS APPROVAL.

A LOAD DURATION INCREASE IS USED IN DESIGN OF ANCHORS INTO WOOD ONLY.

ALL SHIMS TO BE HIGH IMPACT, NON-METALLIC AND NON-COMPRESSIBLE.

MATERIALS INCLUDING BUT NOT LIMITED TO STEEL/METAL SCREWS, THAT COME INTO CONTACT WITH OTHER DISSIMILAR MATERIALS SHALL MEET THE REQUIREMENTS OF THE FLORIDA BUILDING CODE.

PRODUCT REVISED as complying with the Florida Building Code  
 Acceptance No. **15-0406.11**  
 Expiration Date **05/29/2021**  
 By *Manuel Perez*  
 Miami Dade Product Control

SETTING BLOCKS AT LAM. GLASS AND INSUL. LAM. GLASS NOTCH GLAZING BEAD LEG TO CLEAR BLOCKS

Engr: JAVAD AHMAD  
 CIVIL  
 FLA. PE # 70592  
 C.A.N. 3538  
**JUN 23 2015**

**af c**  
**AL-FAROOQ CORPORATION**  
 ENGINEERS & PRODUCT DEVELOPMENT  
 1235 S.W. 87 AVE  
 MIAMI, FLORIDA 33174  
 TEL. (305) 264-8100 FAX. (305) 262-6978  
 COMP-ANL\W11-10ECO

---

S-550 ALUMINUM FIXED WINDOW (L.M.I.)  
**ECO WINDOW SYSTEMS, LLC.**  
 9114 N.W. 106 STREET  
 MEDLEY, FL. 33178  
 TEL. (305) 885-5299 FAX (305) 885-5902

| no | date     | description           | by |
|----|----------|-----------------------|----|
| A  | 01.30.12 | UPDATED TO 2010 FBC   |    |
| B  | 01.11.13 | MANUF. ADDRESS REV.   |    |
| C  | 03.19.15 | UPDATED TO 2014 FBC   |    |
| D  | 06.23.15 | REV. PER REE COMMENTS |    |

date: 02-28-11  
 scale: 1/2"=1'-0"  
 dr. by: HAMID  
 chk. by:

drawing no.  
**W11-10**

sheet 1 of 6



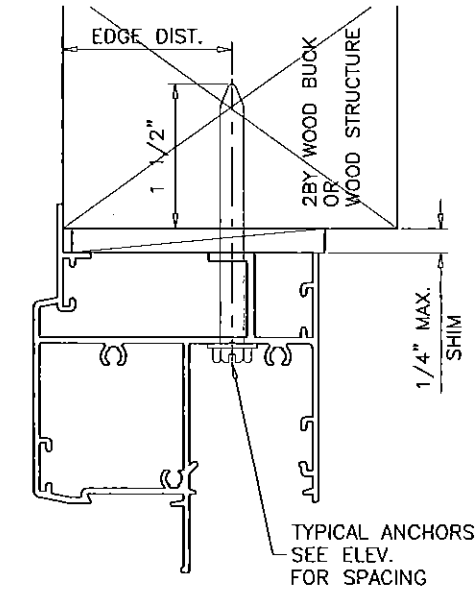
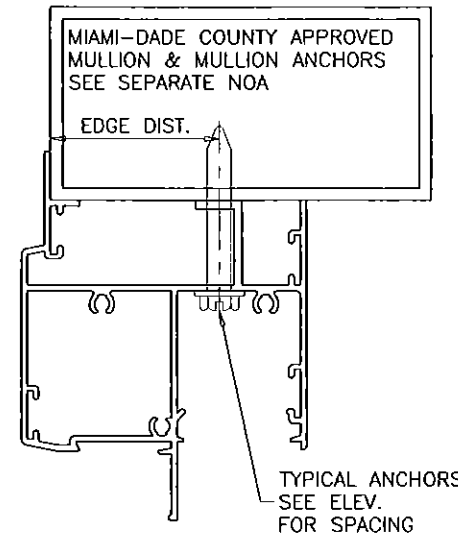
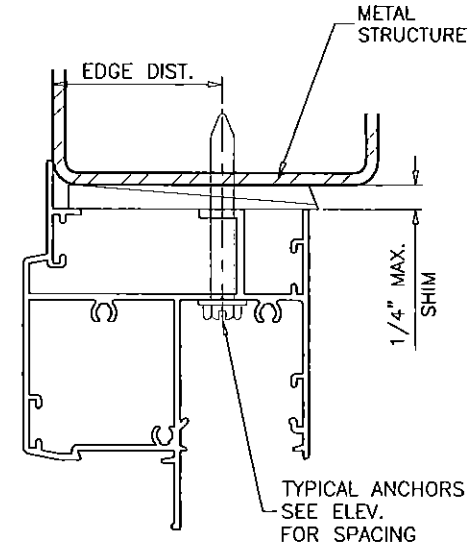
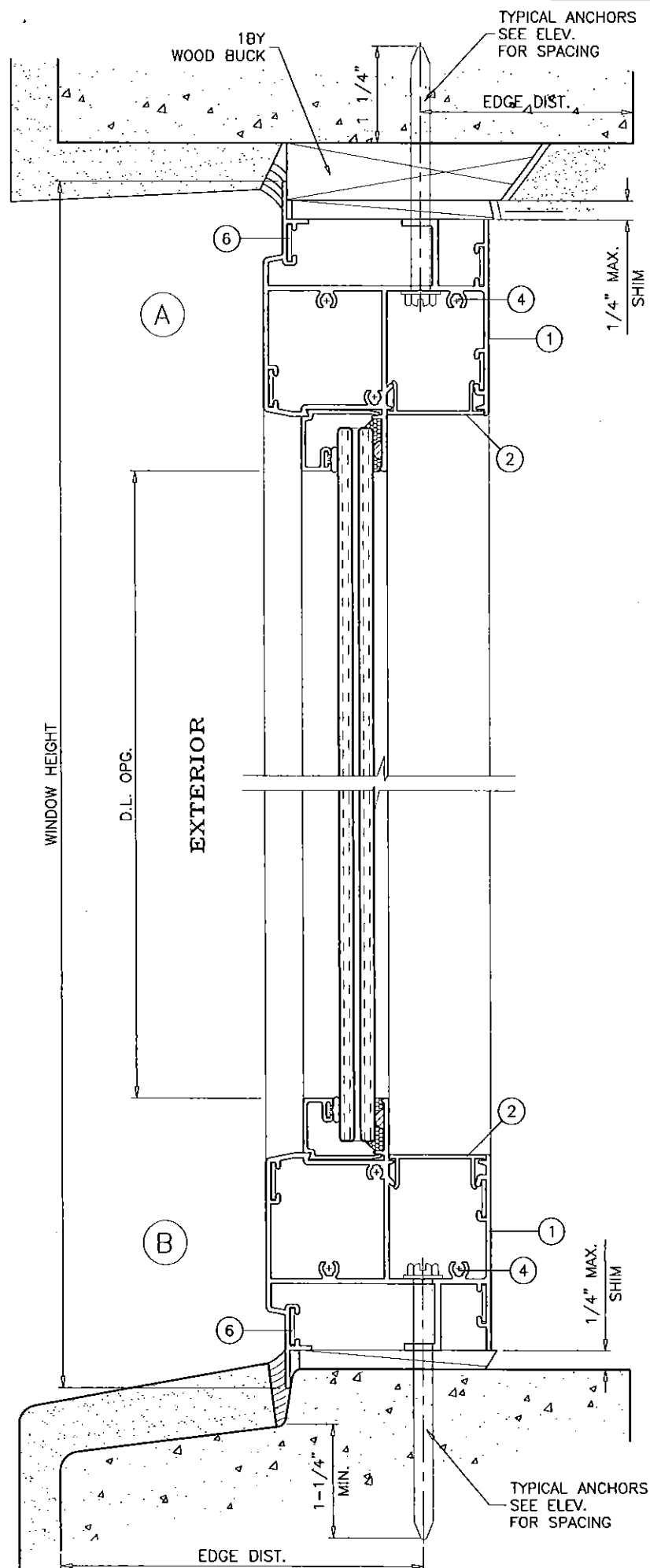

WOOD BUCKS AND METAL STRUCTURE NOT BY ECO WDW. MUST SUSTAIN LOADS IMPOSED BY GLAZING SYSTEM AND TRANSFER THEM TO THE BUILDING STRUCTURE.

**TYPICAL ANCHORS:** SEE ELEV. FOR SPACING  
**1/4" DIA. ULTRACON BY 'ELCO'** ( $F_u=177$  KSI,  $F_y=155$  KSI)  
 INTO 2BY WOOD BUCKS OR WOOD STRUCTURES  
 1-1/2" MIN. PENETRATION INTO WOOD (HEAD/SILL/JAMBS)  
 THRU 1BY BUCKS INTO CONC. OR MASONRY  
 1-1/4" MIN. EMBED INTO CONCRETE (HEAD/SILL)  
 1-1/4" MIN. EMBED INTO CONC. OR MASONRY (JAMBS)  
 DIRECTLY INTO CONC. OR MASONRY  
 1-1/4" MIN. EMBED INTO CONCRETE (HEAD/SILL)  
 1-1/4" MIN. EMBED INTO CONC. OR MASONRY (JAMBS)  
**#14 SMS OR SELF DRILLING SCREWS** (GRADE 2 CRS)  
 INTO METAL STRUCTURES  
 STEEL : 1/8" THK. MIN. ( $F_y = 36$  KSI MIN.)  
 ALUMINUM : 1/8" THK. MIN. (6063-T5 MIN.)  
 (STEEL IN CONTACT WITH ALUMINUM TO BE PLATED OR PAINTED)  
**#12 SMS OR SELF DRILLING SCREWS** (GRADE 2 CRS)  
 INTO MIAMI-DADE COUNTY APPROVED MULLIONS (MIN. THK. = 1/8")  
 (NO SHIM SPACE)  
**TYPICAL EDGE DISTANCE**  
 INTO CONCRETE AND MASONRY = 2-1/2" MIN.  
 INTO WOOD STRUCTURE = 1" MIN.  
 INTO METAL STRUCTURE = 3/4" MIN.  
 WOOD AT HEAD, SILL OR JAMBS SG = 0.55 MIN.  
 CONCRETE AT HEAD, SILL OR JAMBS  $f'_c = 3000$  PSI MIN.  
 C-90 HOLLOW/FILLED NORMAL WEIGHT CMU AT JAMBS  $f'_m = 2000$  PSI MIN.

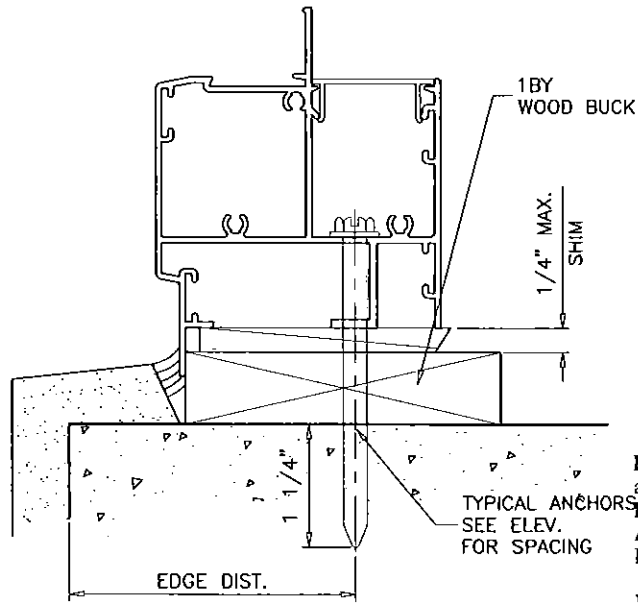

PRODUCT REVISED as complying with the Florida Building Code  
 Acceptance No. **15-0406.11**  
 Expiration Date **05/05/2021**  
 By *Manuel*  
 Miami Dade Product Control

Engr: JAVAD AHMAD  
 CIVIL  
 FLA. PE # 70592  
 C.A.N. 8538  
  
 JUN 23 2015

**AL-FAROOQ CORPORATION**  
 ENGINEERS & PRODUCT DEVELOPMENT  
 1235 S.W. 87 AVE  
 MIAMI, FLORIDA 33174  
 TEL. (305) 264-8100 FAX. (305) 262-6978  
 COMP-ANL W11-10ECO

S-550 ALUMINUM FIXED WINDOW (L.M.I.)  
**ECO WINDOW SYSTEMS, LLC.**  
 9114 N.W. 106 STREET  
 MEDLEY, FL. 33178  
 TEL. (305) 885-5299 FAX (305) 885-5902

| no | date     | description           |
|----|----------|-----------------------|
| A  | 01.30.12 | NO CHANGE THIS SHEET  |
| B  | 10.11.13 | MANUF. ADDRESS REV.   |
| C  | 03.19.15 | UPDATED TO 2014 FBC   |
| D  | 06.23.15 | REV. PER RER COMMENTS |

date: 02-28-11  
 scale: 1/2" = 1"  
 dr. by: HAMID  
 chk. by:  
 drawing no. **W11-10**  
 sheet **3** of **6**

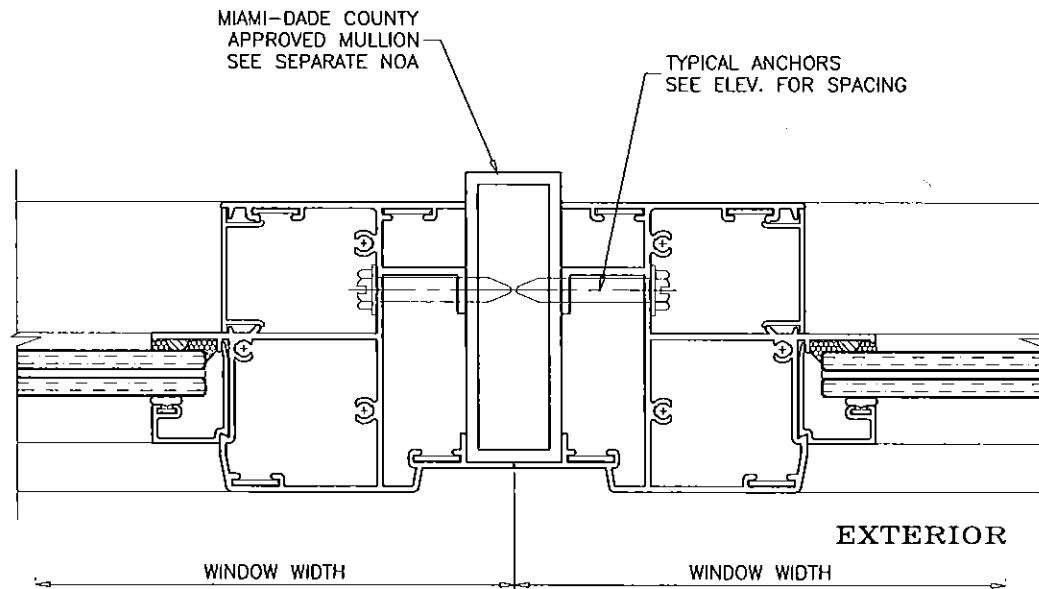
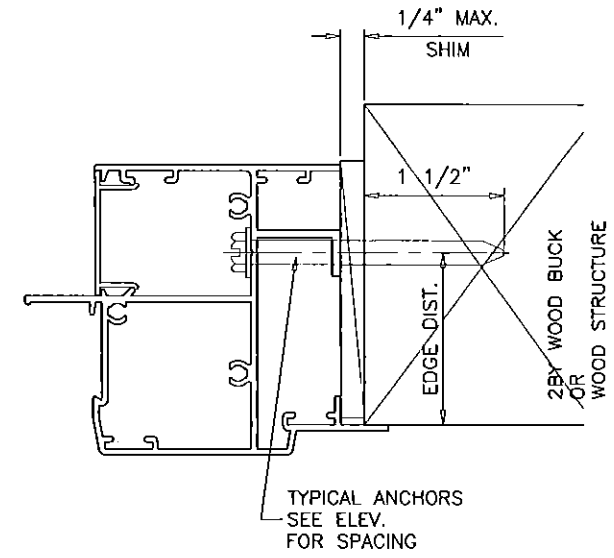
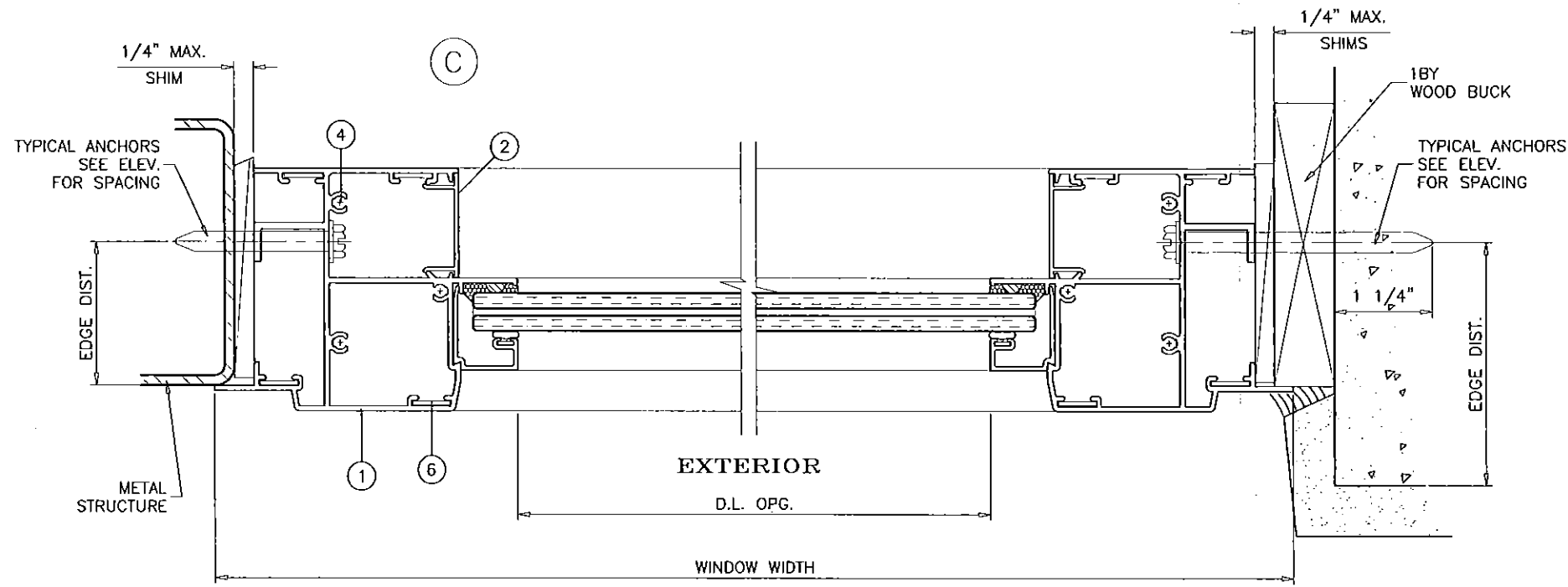

PRODUCT REVISED  
 as complying with the Florida  
 Building Code **15-0406.11**  
 Acceptance No  
 Expiration Date **05/05/2021**  
 By *Manuel Arz*  
 Miami Dade Product Control

Engr: JAVAD AHMAD  
 CIVIL  
 FLA. PE # 70592  
 C.A.N. 3538  
*[Signature]*  
 JUN 23 2015

**afc**  
**AL-FAROOQ CORPORATION**  
 ENGINEERS & PRODUCT DEVELOPMENT  
 1235 S.W. 87 AVE  
 MIAMI, FLORIDA 33174  
 TEL. (305) 264-8100 FAX. (305) 262-6978  
 COMP-ANL\W11-10ECO

S-550 ALUMINUM FIXED WINDOW (L.M.I.)  
**ECO WINDOW SYSTEMS, LLC.**  
 9114 N.W. 106 STREET  
 MEDLEY, FL. 33178  
 TEL. (305) 885-5299 FAX (305) 885-5902

| no | date     | by | description          |
|----|----------|----|----------------------|
| A  | 01.30.12 |    | NO CHANGE THIS SHEET |
| B  | 01.11.13 |    | MANUF. ADDRESS REV.  |
| C  | 03.19.15 |    | UPDATED TO 2014 FBC  |
| D  | 06.23.15 |    | NO CHANGE THIS SHEET |

date: 02-28-11  
 scale: 1/2" = 1"  
 dr. by: HAMID  
 chk. by:

drawing no.  
**W11-10**  
 sheet 4 of 6

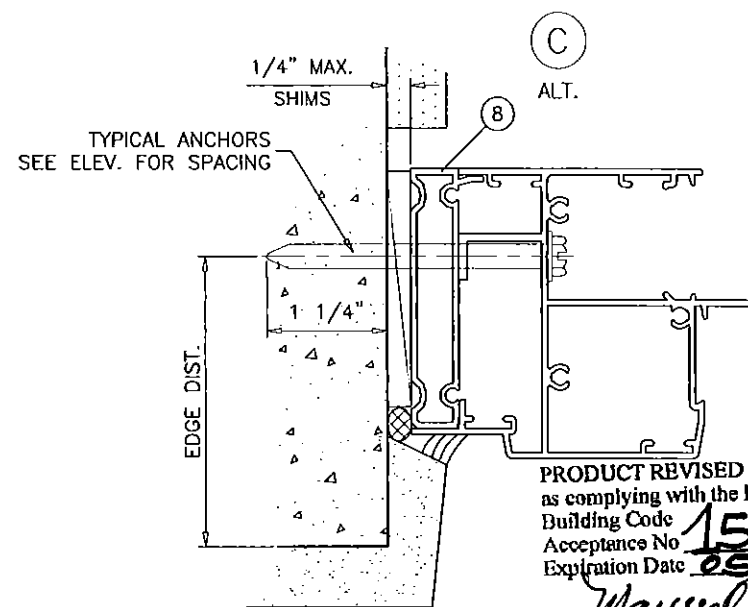
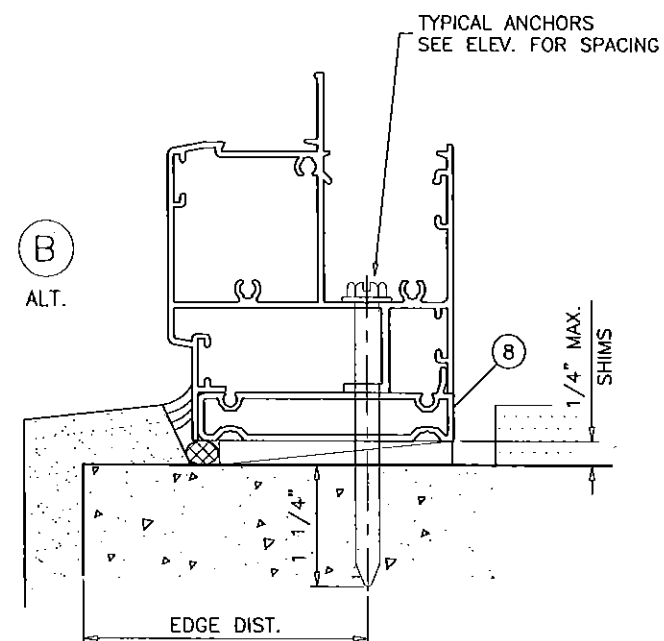
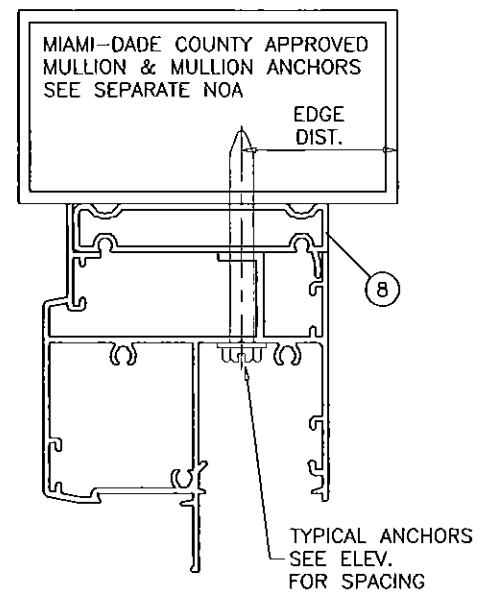
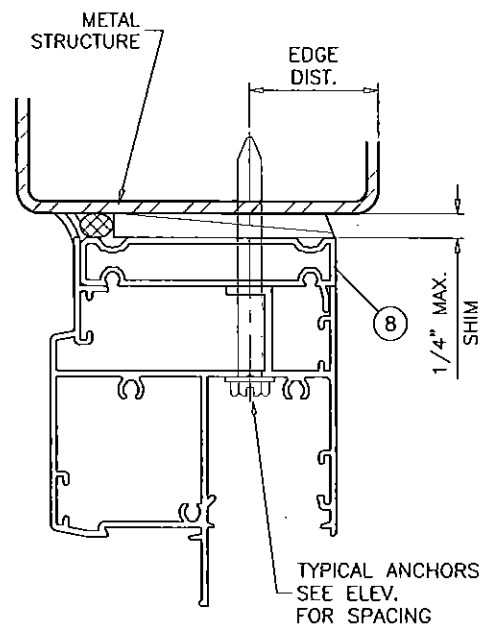
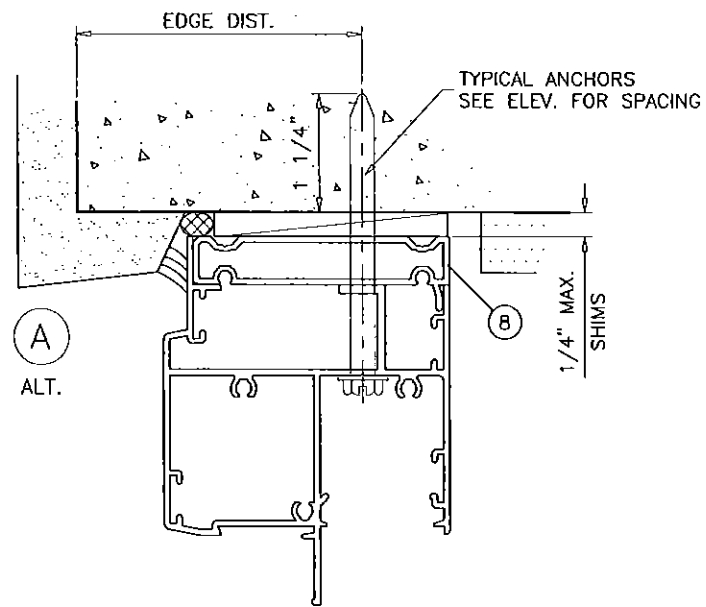

PRODUCT REVISED  
 as complying with the Florida  
 Building Code **15-0406.11**  
 Acceptance No  
 Expiration Date **05/05/2021**  
 By *Manuel Ferrer*  
 Miami Dade Product Control

INSTALLATION DETAILS WITH FLUSH FRAME ADAPTER

Engr: JAVAD AHMAD  
 CIVIL  
 FLA. PE # 70592  
 C.A.N. 3538

JUN 23 2015

**afc**  
**AL-FAROQ CORPORATION**  
 ENGINEERS & PRODUCT DEVELOPMENT  
 1235 S.W. 87 AVE  
 MIAMI, FLORIDA 33174  
 TEL. (305) 264-8100 FAX. (305) 262-6978  
 COMP-ANL W11-10ECO

S-550 ALUMINUM FIXED WINDOW (L.M.I.)  
**ECO WINDOW SYSTEMS, LLC.**  
 9114 N.W. 106 STREET  
 MEDLEY, FL. 33178  
 TEL. (305) 885-5299 FAX (305) 885-5902

| no | date     | by | description          |
|----|----------|----|----------------------|
| A  | 01.30.12 |    | NO CHANGE THIS SHEET |
| B  | 01.11.13 |    | MANUF. ADDRESS REV.  |
| C  | 03.19.15 |    | UPDATED TO 2014 FBC  |
| D  | 06.23.15 |    | NO CHANGE THIS SHEET |

date: 02-28-11  
 scale: 1/2" = 1"  
 dr. by: HAWID  
 chk. by:

drawing no.  
**W11-10**  
 sheet 5 of 6



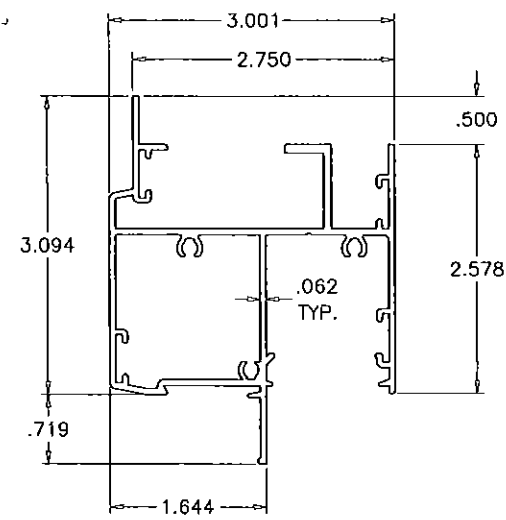

① FRAME HEAD/SILL/JAMB

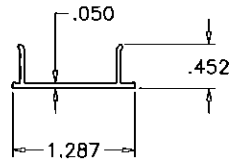

② SNAP COVER

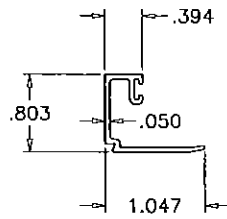

③ GLAZING BEAD (7/16" LAM. GLASS)

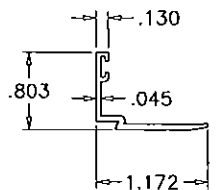

③A GLAZING BEAD (INSUL. LAM. GLASS)

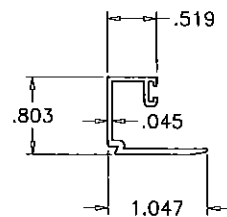

③B GLAZING BEAD (5/16" LAM. GLASS)

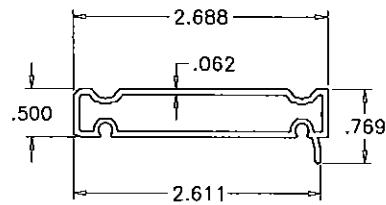

⑧ FLUSH FRAME ADAPTER

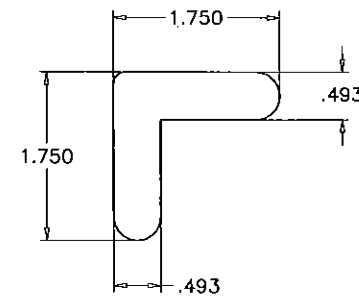

⑥ CORNER KEY

| ITEM | PART #       | QUANTITY  | DESCRIPTION                           | MATERIAL   | MANF./SUPPLIER/REMARKS |
|------|--------------|-----------|---------------------------------------|------------|------------------------|
| 1    | E503         | 4         | FRAME HEAD/SILL/JAMB                  | 6063-T6    | -                      |
| 2    | E504         | 4         | SNAP COVER                            | 6063-T6    | -                      |
| 3    | FY109        | AS REQD.  | GLAZING BEAD (7/16" LAM. GLASS)       | 6063-T6    | -                      |
| 3A   | E505         | AS REQD.  | GLAZING BEAD (INSUL. LAM. GLASS)      | 6063-T6    | -                      |
| 3B   | FY108        | AS REQD.  | GLAZING BEAD (5/16" LAM. GLASS)       | 6063-T6    | -                      |
| 4    | #10 X 1-1/4" | 3/ CORNER | ASSEMBLY SCREWS                       | -          | -                      |
| 5    | E203         | AS REQD.  | GLAZING BEAD BULB, DUROMETER 65       | SANTOPRENE | ULTRAFAB               |
| 6    | PSJ40-SS     | 2/ CORNER | FRAME CORNER KEY                      | ST. STEEL  | -                      |
| 7    | FLB-50       | -         | GLASS SPACER - 1/8" HIGH              | SILICONE   | FRANK LOWE             |
| 8    | FY120        | AS REQD.  | FLUSH FRAME ADAPTER                   | 6063-T6    | OPTIONAL               |
| 9    | -            | AS REQD.  | SETTING BLOCK, 3/16" X 3/4" X 4" LONG | EPDM       | DUROMETER 80±5 SHORE A |
| 10   | -            | -         | INSUL. GLASS EDGE SPACER              | ST. STEEL  | CARDINAL XL            |

**SEALANT:**

ALL JOINTS AND FRAME CONNECTIONS SEALED WITH SCHNEE-MOREHEAD SM5504 SEAM SEALER.

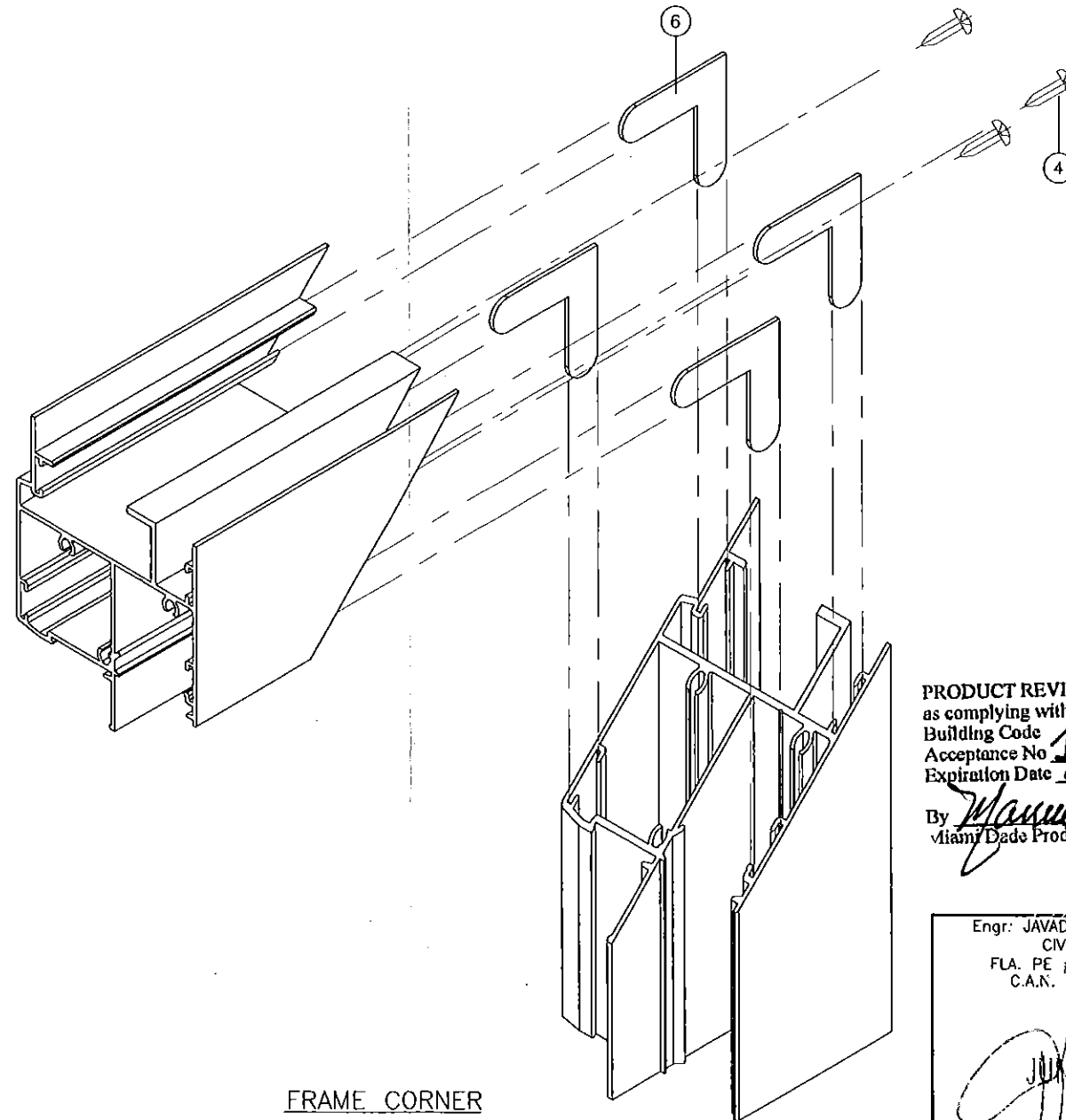

FRAME CORNER

PRODUCT REVISED  
as complying with the Florida  
Building Code  
Acceptance No **15-0406.11**  
Expiration Date **05/05/2021**  
By *Manuel Perez*  
Miami Dade Product Control

Engr: JAVAD AHMAD  
CIVIL  
FLA. PE # 70592  
C.A.N. 8538

*Manuel Perez*  
JUN 23 2015

**afC**  
**AL-FAROOQ CORPORATION**  
ENGINEERS & PRODUCT DEVELOPMENT  
1235 S.W. 87 AVE  
MIAMI, FLORIDA 33174  
TEL. (305) 264-8100 FAX. (305) 262-6978  
COMP-ANL\W11-10ECO

S-550 ALUMINUM FIXED WINDOW (L.M.I.)  
**ECO WINDOW SYSTEMS, LLC.**  
9114 N.W. 106 STREET  
MEDLEY, FL. 33178  
TEL. (305) 885-5299 FAX (305) 885-5902

| no | date     | description           | by |
|----|----------|-----------------------|----|
| A  | 01.30.12 | NO CHANGE THIS SHEET  |    |
| B  | 01.11.13 | MANUF. ADDRESS REV.   |    |
| C  | 03.19.15 | UPDATED TO 2014 FBC   |    |
| D  | 06.23.15 | REV. PER RER COMMENTS |    |

date: 02-28-11  
scale: 1/2" = 1"  
dr. by: HAMID  
chk. by:

drawing no.  
**W11-10**  
sheet 6 of 6