



DEPARTMENT OF REGULATORY AND ECONOMIC RESOURCES (RER)
 BOARD AND CODE ADMINISTRATION DIVISION
NOTICE OF ACCEPTANCE (NOA)

MIAMI-DADE COUNTY
 PRODUCT CONTROL SECTION
 11805 SW 26 Street, Room 208
 Miami, Florida 33175-2474
 T (786) 315-2590 F (786) 315-2599
www.miamidade.gov/economy

JB Garage Door, Inc.
 12195 NW 98th Avenue
 Hialeah Gardens, FL 33018

SCOPE:

This NOA is being issued under the applicable rules and regulations governing the use of construction materials. The documentation submitted has been reviewed and accepted by Miami-Dade County RER-Product Control Section to be used in Miami Dade County and other areas where allowed by the Authority Having Jurisdiction (AHJ).

This NOA shall not be valid after the expiration date stated below. The Miami-Dade County Product Control Section (In Miami Dade County) and/or the AHJ (in areas other than Miami Dade County) reserve the right to have this product or material tested for quality assurance purposes. If this product or material fails to perform in the accepted manner, the manufacturer will incur the expense of such testing and the AHJ may immediately revoke, modify, or suspend the use of such product or material within their jurisdiction. RER reserves the right to revoke this acceptance, if it is determined by Miami-Dade County Product Control Section that this product or material fails to meet the requirements of the applicable building code.

This product is approved as described herein, and has been designed to comply with the Florida Building Code, including the High Velocity Hurricane Zone.

DESCRIPTION: Models 724/720 Steel Sectional Garage Door up to 12'-4" Wide x 18' High

APPROVAL DOCUMENT: Drawing No. 96-46, titled "Steel Overhead Garage Door", dated 10/31/1996, with last revision H dated 07/21/2014, sheets 1 through 5 of 5, prepared by Al-Farooq Corporation, signed and sealed by Javad Ahmad, P.E., bearing the Miami-Dade County Product Control renewal stamp with the Notice of Acceptance number and expiration date by the Miami-Dade County Product Control Section.

MISSILE IMPACT RATING: Large and Small Missile Impact Resistant

LABELING: A permanent label with the manufacturer's name or logo, manufacturing address, model number, the positive and negative design pressure rating, indicate impact rated if applicable, installation instruction drawing reference number, approval number (NOA), the applicable test standards, and the statement reading 'Miami-Dade County Product Control Approved' is to be located on the door's side track, bottom angle, or inner surface of a panel.

LIMITATION: This door has not been tested for air infiltration.

RENEWAL of this NOA shall be considered after a renewal application has been filed and there has been no change in the applicable building code negatively affecting the performance of this product.

TERMINATION of this NOA will occur after the expiration date or if there has been a revision or change in the materials, use, and/or manufacture of the product or process. Misuse of this NOA as an endorsement of any product, for sales, advertising or any other purposes shall automatically terminate this NOA. Failure to comply with any section of this NOA shall be cause for termination and removal of NOA.

ADVERTISEMENT: The NOA number preceded by the words Miami-Dade County, Florida, and followed by the expiration date may be displayed in advertising literature. If any portion of the NOA is displayed, then it shall be done in its entirety.

INSPECTION: A copy of this entire NOA shall be provided to the user by the manufacturer or its distributors and shall be available for inspection at the job site at the request of the Building Official.

This NOA **renews NOA # 14-1014.08** and consists of this page 1 and evidence pages E-1 and E-2, as well as approval document mentioned above.

The submitted documentation was reviewed by **Carlos M. Utrera, P.E.**



[Signature]
 10/07/2015

NOA No. 15-0812.15
 Expiration Date: October 16, 2020
 Approval Date: October 15, 2015
 Page 1

NOTICE OF ACCEPTANCE: EVIDENCE SUBMITTED

A. DRAWINGS “Submitted under NOA # 14-1014.08”

1. Drawing No. **96-46**, titled “Steel Overhead Garage Door”, dated 10/31/1996, with last revision H dated 07/21/2014, sheets 1 through 5 of 5, prepared by Al-Farooq Corporation, signed and sealed by Javad Ahmad, P.E.

B. TESTS “Submitted under NOA # 10-0527.02”

1. Test Report on Tensile Test per ASTM E-8 of “Sectional Residential Door (skin)”, prepared by Hurricane Engineering & Testing Inc, Report No. **HETI 08-T113**, dated 03/20/2008, signed and sealed by Candido F. Font, P.E.

“Submitted under NOA # 05-0922.01”

2. Test report on Uniform Static Air Pressure Test per FBC, TAS 202 & Forced Entry Resistance Test per SFBC, Section 3603.2 of Series 724 Garage Door, prepared by Hurricane Engineering & Testing Inc., Report No. **HETI-05-1477**, dated 05/19/2005, signed and sealed by Ivonne Ghia, P.E.
3. Test report on Large Missile Impact Test per FBC, TAS 201 and Cyclic Wind Pressure Test per FBC, TAS 203 of Series 724 Garage Door , prepared by Hurricane Engineering & Testing Inc., Report No. **HETI-05-1457**, dated 05/27/2005, signed and sealed by Ivonne Ghia, P.E.

C. CALCULATIONS “Submitted under NOA # 14-1014.08”

1. Anchoring verification calculations prepared by Al-Farooq Corporation, dated 09/23/2014, signed and sealed by Javad Ahmad, P.E.

“Submitted under NOA # 09-0212.09”

2. Anchoring verification calculations prepared by Al-Farooq Corporation, complying with F.B.C 2007, dated 12/31/2008, signed and sealed by Humayoun Farooq, P.E.

D. QUALITY ASSURANCE

1. Miami-Dade Department of Regulatory and Economic Resources (RER)



10/07/2015

Carlos M. Utrera, P.E.
Product Control Examiner
NOA No. 15-0812.15
Expiration Date: October 16, 2020
Approval Date: October 15, 2015

NOTICE OF ACCEPTANCE: EVIDENCE SUBMITTED

E. MATERIAL CERTIFICATIONS

1. Notice of Acceptance No. **14-0311.08**, issued to Insulfoam, LLC, for their Insulfoam Expanded Polystyrene Insulation, approved on 08/14/2014 and expiring on 11/29/2017.
2. Notice of Acceptance No. **11-0926.07**, issued to Dyplast Products, LLC, for their Expanded Polystyrene Block Type Insulation, approved on 11/10/2011 and expiring on 01/11/2017.
3. Notice of Acceptance No. **11-0926.06**, issued to Dyplast Products, LLC, for their Dyplast ISO-C1 Polyisocyanurate Insulation, approved on 11/10/2011 and expiring on 01/11/2017.
4. Notice of Acceptance No. **10-1129.04**, issued to Cellofoam North America Inc, for their Expanded Polystyrene Block Insulation, approved on 02/24/2011 and expiring on 02/24/2016.

F. STATEMENTS *"Submitted under NOA # 14-1014.08"*

1. Statement letter of code conformance to the 5th edition (2014) FBC and no financial interest issued by Al-Farooq Corporation, dated 09/23/2014, signed and sealed by Javad Ahmad, P.E.

"Submitted under NOA # 12-0113.05"

2. Statement letter of code conformance to 2010 FBC and no financial interest issued by Al-Farooq Corporation, dated 11/21/2011, signed and sealed by Javad Ahmad, P.E.

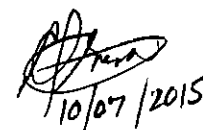

Carlos M. Utrera, P.E.
Product Control Examiner
NOA No. 15-0812.15
Expiration Date: October 16, 2020
Approval Date: October 15, 2015

NO	DATE	DESCRIPTION
D	11.11.05	REV. PER BCDD COMMENTS
E	01.02.09	UPDATED FOR 2007 FBC
F	01.06.10	ENGR. NAME CHANGED
G	11.21.11	UPDATED TO 2010 FBC
H	07.21.14	UPDATED TO 2014 FBC

date:	10-31-96
scale:	NONE
dr. by:	HAMID
chk. by:	
drawing no.	96-46
sheet	1 of 5

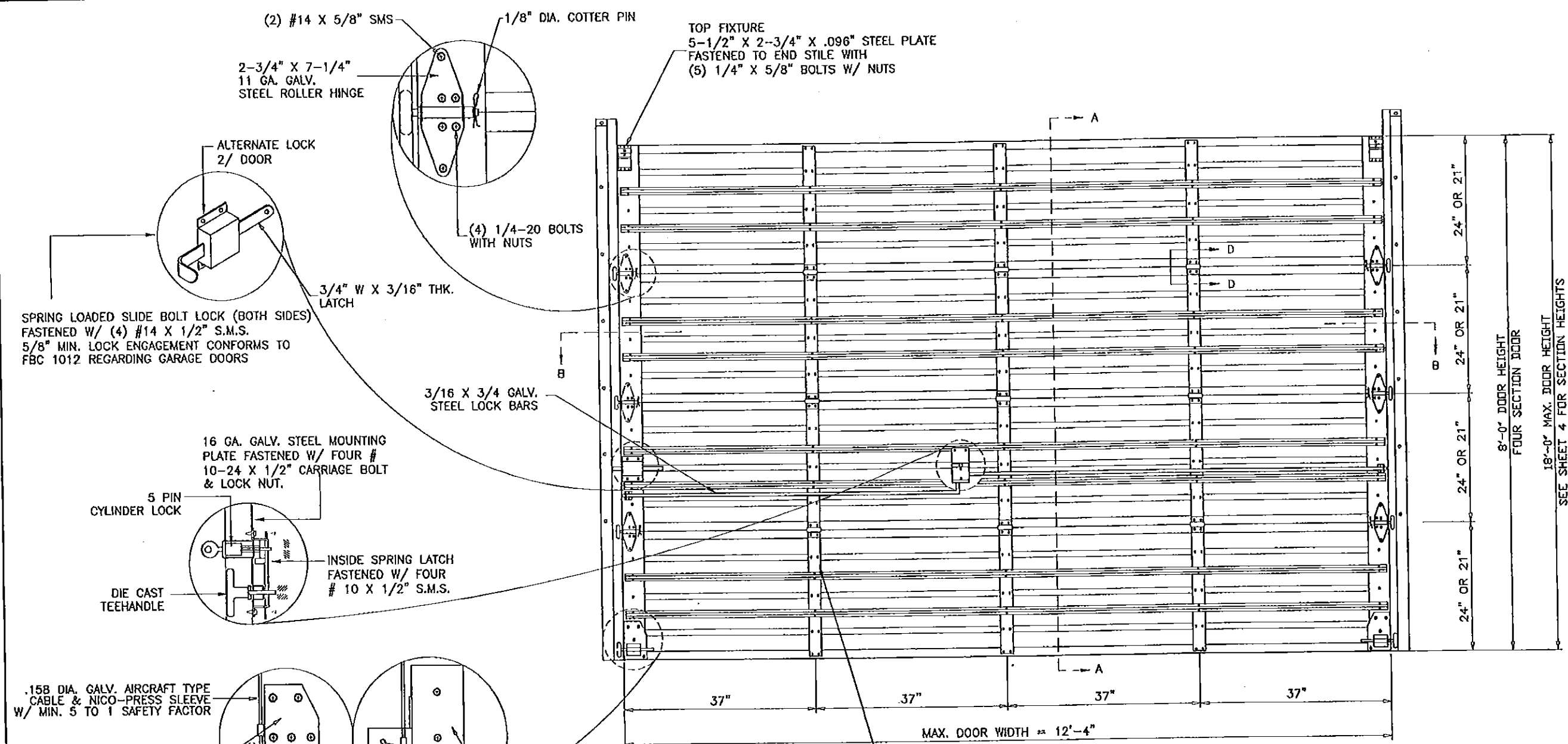

INSIDE ELEVATION

END HINGES WITH PINS IN ROLLER SHAFTS

J.B. DOOR MODELS: 12'-4"W X 18'H MAX	
MODEL	DESCRIPTION
724	24 GA. ROLL FORMED STEEL DOOR
720	20 GA. ROLL FORMED STEEL DOOR

NOTE: MODEL 724 TESTED.

THIS PRODUCT IS RATED FOR LARGE MISSILE IMPACT

MAXIMUM DESIGN LOAD RATING = + 60.0 PSF
 (FOR SIZES SHOWN OR SMALLER) - 60.0 PSF

GENERAL NOTES

1. THIS PRODUCT HAS BEEN DESIGNED AND TESTED TO COMPLY WITH THE REQUIREMENTS OF THE FLORIDA BUILDING CODE (FBC) FIFTH EDITION (2014) INCLUDING HIGH VELOCITY HURRICANE ZONE (HVHZ).
2. ANCHORS SHALL BE AS LISTED, SPACED AS SHOWN ON DETAILS. ANCHOR EMBEDMENT TO BASE MATERIAL SHALL BE BEYOND WALL DRESSING OR STUCCO.
3. ALL BOLTS, NUTS AND WASHERS SHALL BE ZINC PLATED CARBON STEEL.
4. ANCHORING OR LOADING CONDITIONS OTHER THAN THOSE SHOWN IN THESE DETAILS ARE NOT PART OF THIS APPROVAL.
5. A LOAD DURATION INCREASE IS USED IN DESIGN OF ANCHORS INTO WOOD ONLY.

PRODUCT RENEWED
 as complying with the Florida Building Code
 Acceptance No 15-081215
 Expiration Date 10/16/2020
 By *[Signature]*
 Miami Trade Product Control

Engr: JAVAD AHMAD
 CIVIL
 FLA. PE # 70592
 C.A.N. 3530
[Signature]
 SEP 22 2014

PRODUCT REVISED
 as complying with the Florida Building Code
 Acceptance No 14-1214-08
 Expiration Date 10/16/2015
 By *[Signature]*
 Miami Trade Product Control

afC
AL-FAROOQ CORPORATION
 ENGINEERS & PRODUCT DEVELOPMENT
 1235 S.W. 87 AVE
 MIAMI, FLORIDA 33174
 TEL. (305) 264-8100 FAX (305) 262-6978
 GARAGE 96-46JB

STEEL OVERHEAD GARAGE DOOR
J.B. GARAGE DOORS INC.
 12195 N.W. 98 TH. AVE.
 HIALEAH GARDENS, FL. 33016
 TEL (305) 558 - 1658

no	date	description
D	11.11.05	REV. PER BCCO COMMENTS
E	01.02.09	UPDATED FOR 2007 FBC
F	01.06.10	ENGR. NAME CHANGED
G	11.21.11	NO CHANGE THIS SHEET
H	07.21.14	NO CHANGE THIS SHEET

date: 10-31-96
 scale: NONE
 dr. by: HAMID
 chk. by:
 drawing no.
96-46
 sheet 2 of 5

1-1/4" X 2-1/2" X 14 GA.
 GALV. STEEL CONT. ANGLE
 FASTENED TO WOOD JAMBS
 W/ 5/16 X 1-5/8" LAG SCREWS
 (FULLY THREADED)
 HEX WASHER HEAD TYPE A
 AT 3" FROM EACH END
 AND 12" O.C. MAX.

OPTIONAL STOP MOULDING
 BY DOOR INSTALLER

3 X 2 X .052" THK.
 DIE FORMED STEEL END STILE
 RIVETED TO SECTION SKIN
 WITH (10) RIVETS

1/4-20 X 5/8" HEX HEAD
 M.S. & LOCK NUT 4/ HINGE

STEEL STRUCTURE BY OTHERS
 MUST SUPPORT THE LOADS IMPOSED
 BY DOOR SYSTEM

(4) 1/4 X 5/8"
 BOLTS WITH NUTS

1/4" X 5/8" S.M.S.
 2/ HINGE

2-1/2" X 3-7/8" X 12 GA.
 GALV. STEEL TRACK PLATES @
 12" O.C. SPOT WELDED TO 14
 GA. ANGLE

FOR CONNECTION OF WOOD BUCK
 TO MASONRY SEE NOTE ON SHEET 5
 FOR CONNECTION DIRECTLY TO CONCRETE
 SEE ALTERNATE DETAIL SHEET 5
 CONNECTION TO METAL BUILDING TO BE
 ENGINEERED ON JOB TO JOB BASIS.

ROLLER HINGE

2-3/4" X 2-1/4" X 14 GA.
 GALV. STEEL CENTER HINGE

1.82" DIA. X .50" ROLLERS
 W/ .43 DIA. X 7" STEM

1/8" DIA. COTTER PIN

1" X 2" X 14 GA. GALV. STEEL
 TRACK FASTENED TO TRACK PLATES
 W/ (2) 1/4-20 X 5/8" TRUSS HD.
 SLOTTED M.S. & LOCK NUT

INTERIOR SIDE

SECTION B-B

PRODUCT RENEWED
 as complying with the Florida
 Building Code
 Acceptance No 15-0812.15
 Expiration Date 10/16/2020
 By *[Signature]*
 Miami Dade Product Control

Engr: JAVAD AHMAD
 CIVIL
 FLA. PE # 70592
 C.A.N. 3539
 SEP 28 2014

PRODUCT REVISED
 as complying with the Florida
 Building Code
 Acceptance No 14-1014.08
 Expiration Date 10/16/2015
 By *[Signature]*
 Miami Dade Product Control

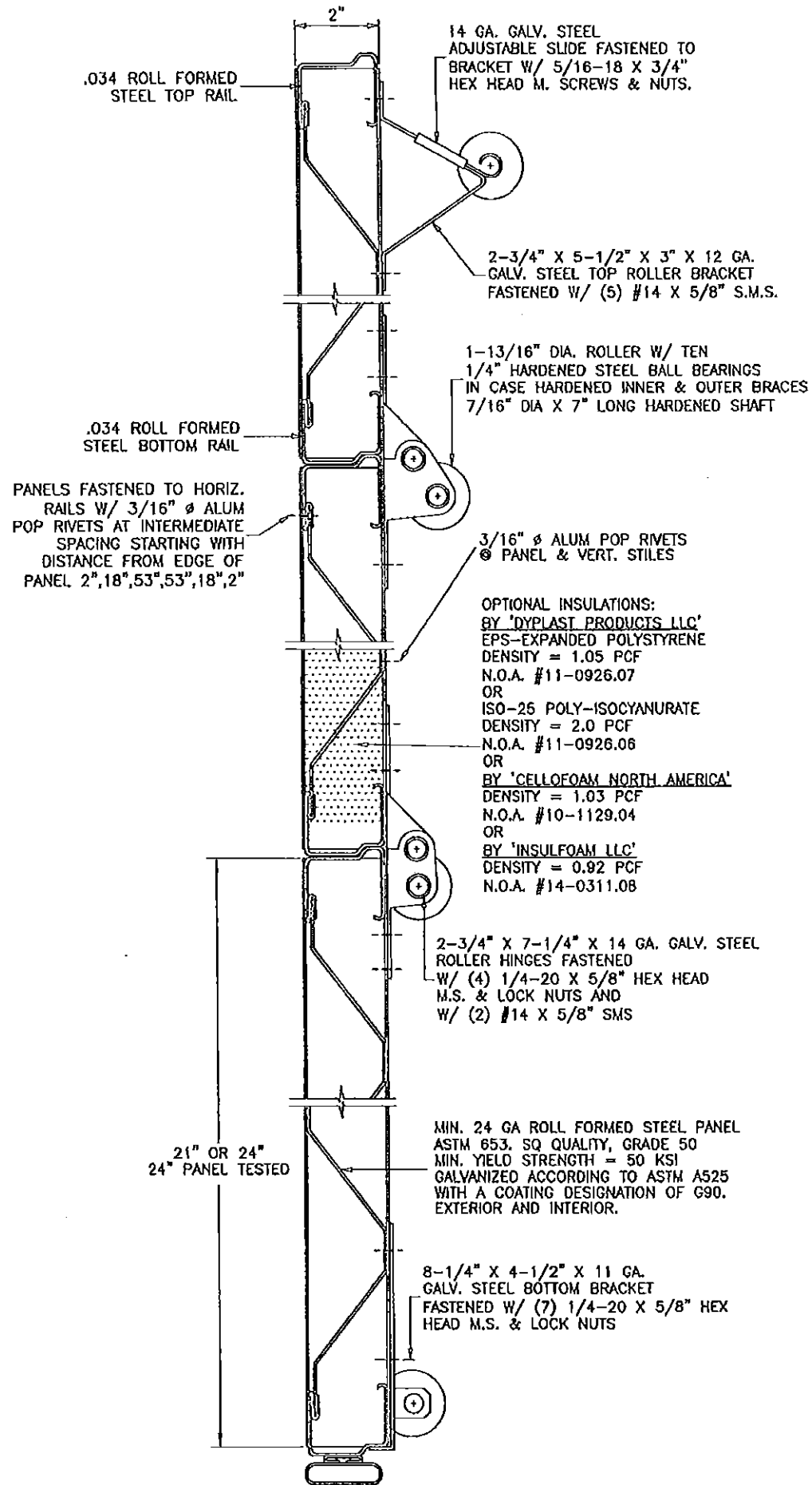

SECTION A-A

SEE SECTIONS AT RIGHT FOR LOCATION OF REINFORCING TRUSSES

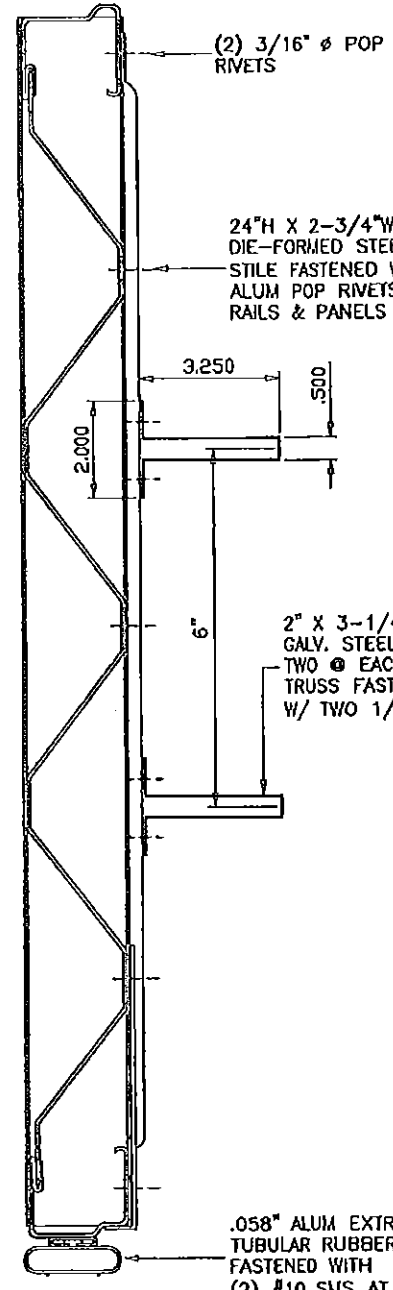

PANEL SECTION REINFORCEMENT

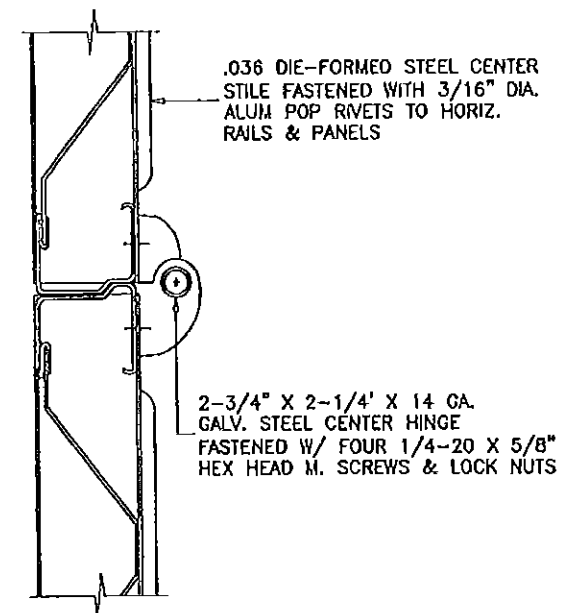

SECTION D-D

PRODUCT RENEWED
 as complying with the Florida Building Code
 Acceptance No 15-0812.15
 Expiration Date 10/16/2020
 By *[Signature]*
 Miami Trade Product Control

Engr: JAVAD AHMAD
 CML
 FLA. PE # 70592
 C.A.N. 3538
 SEP 22 2014

PRODUCT REVISED
 as complying with the Florida Building Code
 Acceptance No 14-1014.08
 Expiration Date 10/16/2015
 By *[Signature]*
 Miami Trade Product Control

af c
AL-FAROOQ CORPORATION
 ENGINEERS & PRODUCT DEVELOPMENT
 1235 S.W. 87 AVE
 MIAMI, FLORIDA 33174
 TEL. (305) 264-8100 FAX (305) 262-6978
 GARAGE 96-46/B

STEEL OVERHEAD GARAGE DOOR
J.B. GARAGE DOORS INC.
 12195 N.W. 98 TH. AVE.
 HIALEAH GARDENS, FL. 33016
 TEL (305) 558 - 1658

Revisions:

no	date	description
D	11.11.05	REV. PER BCCO COMMENTS
E	01.02.09	UPDATED FOR 2007 FBC
F	01.06.10	ENGR. NAME CHANGED
G	11.21.11	NO CHANGE THIS SHEET
H	07.21.14	UPDATED TO 2014 FBC

date: 10-31-96
 scale: NONE
 dr. by: HAVID
 chk. by:
 drawing no.
96-46
 sheet 3 of 5

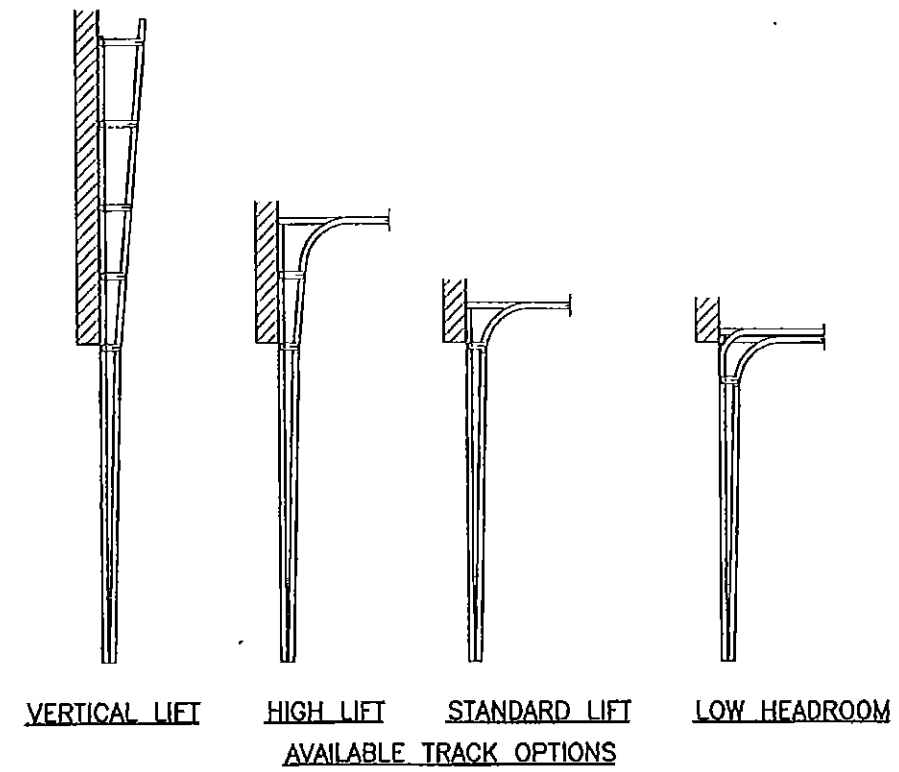
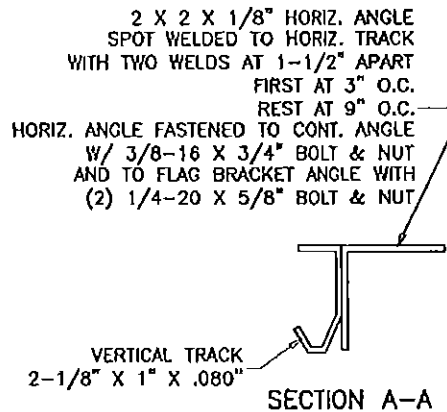
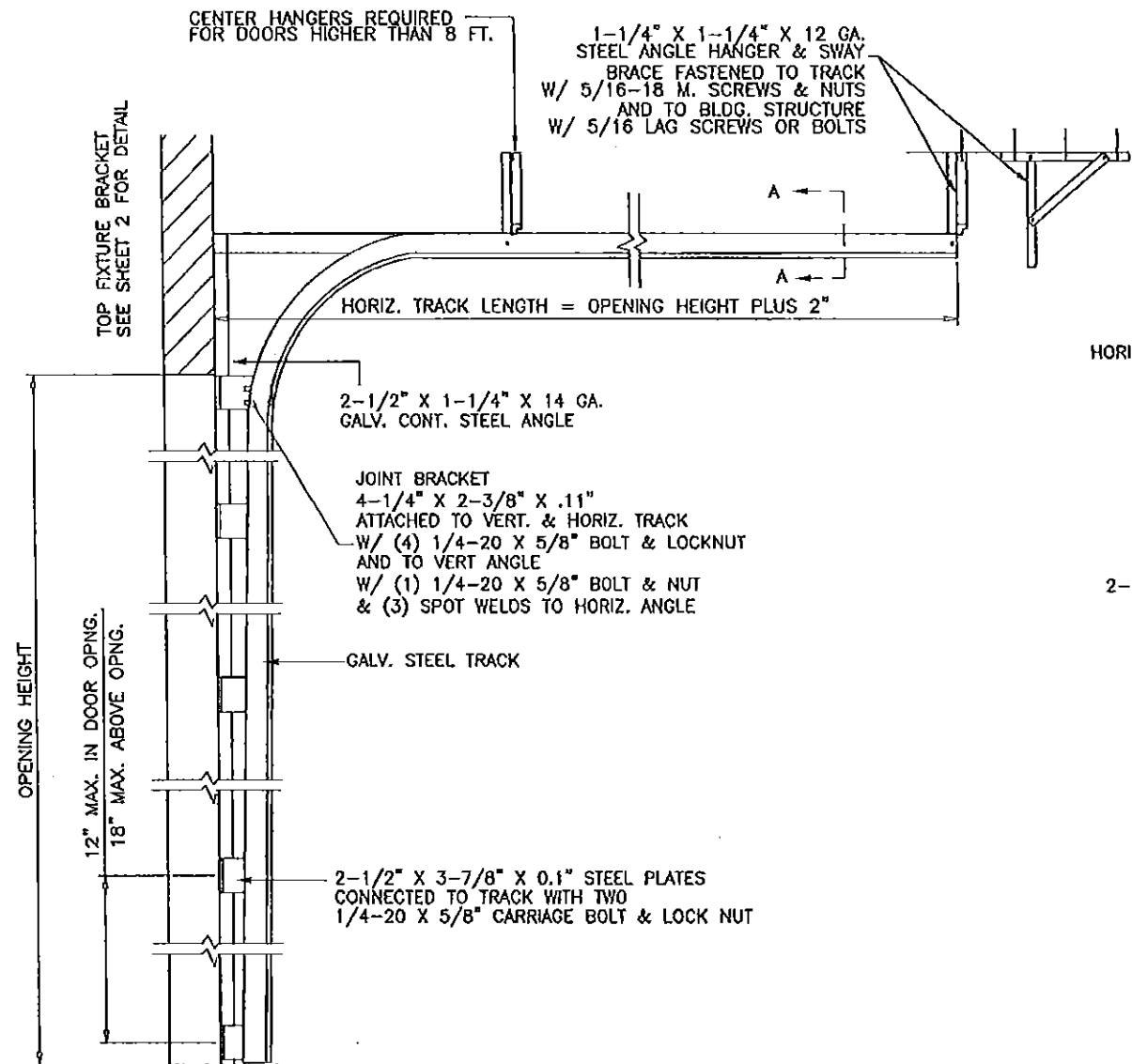

DOOR TRACK AS VIEWED FROM CENTER OF OPENING

DOOR HEIGHT	NO. OF TRUSSES	SECTION HEIGHTS *								
		1ST	2ND	3RD	4TH	5TH	6TH	7TH	8TH	9TH
7'-0"	8	21"	21"	21"	21"	N/A	N/A	N/A	N/A	N/A
8'-0"	8	24"	24"	24"	24"	N/A	N/A	N/A	N/A	N/A
9'-0"	10	24"	21"	21"	21"	21"	N/A	N/A	N/A	N/A
10'-0"	10	24"	24"	24"	24"	24"	N/A	N/A	N/A	N/A
11'-0"	12	24"	24"	21"	21"	21"	21"	N/A	N/A	N/A
12'-0"	12	24"	24"	24"	24"	24"	24"	N/A	N/A	N/A
13'-0"	14	24"	24"	24"	21"	21"	21"	21"	N/A	N/A
14'-0"	14	24"	24"	24"	24"	24"	24"	24"	N/A	N/A
15'-0"	16	24"	24"	24"	24"	21"	21"	21"	21"	N/A
16'-0"	16	24"	24"	24"	24"	24"	24"	24"	24"	N/A
17'-0"	18	24"	24"	24"	24"	24"	21"	21"	21"	21"
18'-0"	18	24"	24"	24"	24"	24"	24"	24"	24"	24"

*--SECTIONS ARE NUMBERED STARTING AT THE BOTTOM

PRODUCT RENEWED as complying with the Florida Building Code
 Acceptance No 15-0912.15
 Expiration Date 10/16/2020
 By *[Signature]*
 Miami Dade Product Control

Engr: JAWAD AHMAD
 CIVIL
 FLA. PE # 70592
 C.A.N. 3538
 SEP 22 2014

PRODUCT REVISED as complying with the Florida Building Code
 Acceptance No 14-1014.08
 Expiration Date 10/16/2015
 By *[Signature]*
 Miami Dade Product Control

af c
AL-FAROOQ CORPORATION
 ENGINEERS & PRODUCT DEVELOPMENT
 1235 S.W. 87 AVE
 MIAMI, FLORIDA 33174
 TEL (305) 264-8100 FAX (305) 262-6978
 GARAGE\96-46JB

STEEL OVERHEAD GARAGE DOOR
J.B. GARAGE DOORS INC.
 12195 N.W. 98 TH. AVE.
 HIALEAH GARDENS, FL 33016
 TEL (305) 558 - 1658

NO	DATE	DESCRIPTION
D	11.11.05	REV. PER BCCO COMMENTS
E	07.02.09	UPDATED FOR 2007 FBC
F	01.06.10	ENGR. NAME CHANGED
G	11.21.11	NO CHANGE THIS SHEET
H	07.21.14	NO CHANGE THIS SHEET

date: 10-31-96
 scale: NONE
 dr. by: HAMID
 chk. by:

drawing no.
96-46
 sheet 4 of 5

ANCHOR SPACING				
ANCHORS	STRUCTURE	EMBED	SPACING	EDGE DIST.
3/8" HLC SLEEVE BY 'HILTI'	CONC.	1-1/4"	8-1/2"	2"
3/8" CONFLEX BY 'ELCO'	FILLED BLOCK	2"	8-1/2"	3-3/4"
3/8" DYNABOLT BY 'ITW'	CONC.	1-1/2"	8-1/2"	3"
3/8" POWER-BOLT BY 'POWERS'	CONC.	2"	8-1/2"	1-7/8"
3/8" SLEEVE-ALL BY 'SIMPSONS'	CONC.	1-1/2"	8-1/2"	3"

CONCRETE f'c = 3000 PSI MIN.
 C-90 GROUT FILLED BLOCK f'm = 2000 PSI MIN.

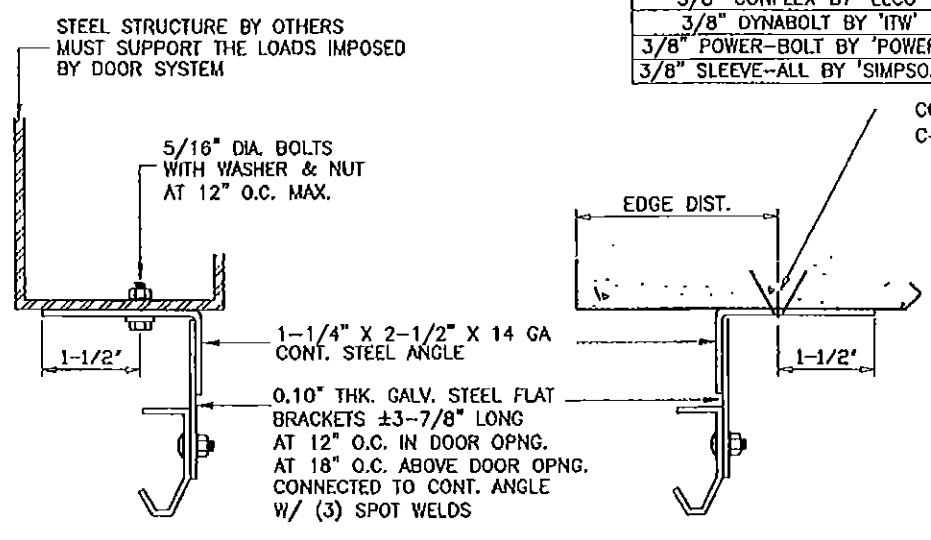

TRACK INSTALLATION

WOOD FRAME BUILDINGS

STUD WALLS OR DOOR OPENING (NOT BY J.B. DOORS) SHALL BE FRAMED SOLID BY NOT LESS THAN (3) 2X6 PRESSURE TREATED GRADE 2 SYP OR BETTER WOOD STUDS.
 STUD WALLS TO BE CONT. FROM FOOTING TO TIE BEAM. ENGINEER OF RECORD TO VERIFY ADEQUACY OF THE SUPPORTING STRUCTURE.

WOOD BUCK CONNECTION TO MASONRY

TRACK SHALL BE SECURED WITH CONT. STEEL ANGLE TO PRESSURE TREATED 2X6 SYP WOOD JAMBS WHICH SHALL BE ANCHORED TO GROUTED REINFORCED MASONRY BLOCK WALL OR CONC. COLUMN WITH

1/4" ULTRACON BY 'ELCO' WITH SPACING OF 8" O.C. INTO GROUT FILLED BLOCK WALL, WITH 2-1/4" MIN. EMBED
 9" O.C. INTO 3000 PSI CONCRETE, WITH 1-3/4" MIN. EMBED
 2-1/2" MIN. EDGE DISTANCE

1/4" TAPPER BY 'POWERS' WITH SPACING OF 6" O.C. INTO GROUT FILLED BLOCK WALL, WITH 1-1/2" MIN. EMBED
 7" O.C. INTO 3000 PSI CONCRETE, WITH 1-3/4" MIN. EMBED
 3" MIN. EDGE DISTANCE

3/8" CONFLEX BY 'ELCO' OR 3/8" LOT BY 'ITW' WITH SPACING OF 15" O.C. INTO 3000 PSI CONCRETE, WITH 2-1/2" MIN. EMBED
 3" MIN. EDGE DISTANCE

3/8" HLC SLEEVE BY 'HILTI' WITH SPACING OF 9" O.C. INTO 3000 PSI CONCRETE, WITH 1-1/4" MIN. EMBED AND 2-1/2" MIN. EDGE DISTANCE

THE BLOCK WALL CELLS SHALL BE GROUT FILLED AND REINFORCED WITH FOUR # 5 BARS EXTENDING INTO FOOTING AND INTO TIE BEAMS ALL BARS SHALL BE CONTINUOUS FROM TIE BEAMS TO FOOTING.

PREPARATION OF JAMBS BY OTHERS

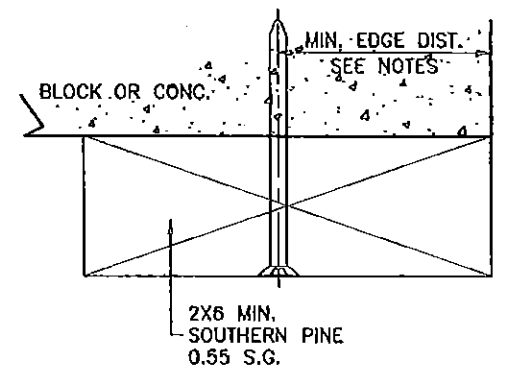

PRODUCT RENEWED
 as complying with the Florida Building Code
 Acceptance No 15-0912.15
 Expiration Date 10/16/2020
 By *[Signature]*
 Miami Trade Product Control

Engr: JAWAD AHMAD
 CIVIL
 FLA. PE # 70592
 C.A.N. 3538
 SEP 22 2014

PRODUCT REVISED
 as complying with the Florida Building Code
 Acceptance No 14-1014.08
 Expiration Date 10/16/2015
 By *[Signature]*
 Miami Trade Product Control

REVISIONS:

NO	DATE	DESCRIPTION
D	11.11.05	REV. PER BCCO COMMENTS
E	01.02.09	UPDATED FOR 2007 FBC
F	01.05.10	ENGR. NAME CHANGED
G	11.21.11	NO CHANGE THIS SHEET
H	07.21.14	UPDATED TO 2014 FBC

date: 10-31-96
 scale: NONE
 dr. by: HAMID
 ckr. by:

drawing no.
96-46
 sheet 5 of 5