



MIAMI-DADE COUNTY
PRODUCT CONTROL SECTION
 11805 SW 26 Street, Room 208
 Miami, Florida 33175-2474
 T (786) 315-2590 F (786) 315-2599
www.miamidade.gov/economy

DEPARTMENT OF REGULATORY AND ECONOMIC RESOURCES (RER)
 BOARD AND CODE ADMINISTRATION DIVISION

NOTICE OF ACCEPTANCE (NOA)

DAB Door Company, Inc.
12195 NW 98th Avenue
Hialeah Gardens, FL 33018

SCOPE:

This NOA is being issued under the applicable rules and regulations governing the use of construction materials. The documentation submitted has been reviewed and accepted by Miami-Dade County RER-Product Control Section to be used in Miami Dade County and other areas where allowed by the Authority Having Jurisdiction (AHJ).

This NOA shall not be valid after the expiration date stated below. The Miami-Dade County Product Control Section (In Miami Dade County) and/or the AHJ (in areas other than Miami Dade County) reserve the right to have this product or material tested for quality assurance purposes. If this product or material fails to perform in the accepted manner, the manufacturer will incur the expense of such testing and the AHJ may immediately revoke, modify, or suspend the use of such product or material within their jurisdiction. RER reserves the right to revoke this acceptance, if it is determined by Miami-Dade County Product Control Section that this product or material fails to meet the requirements of the applicable building code.

This product is approved as described herein, and has been designed to comply with the Florida Building Code, including the High Velocity Hurricane Zone.

DESCRIPTION: Hurricane Master Model 824/811 Steel Sectional Garage Door up to 9'-4" w/ Window Lite Option

APPROVAL DOCUMENT: Drawing No. **01-05**, titled "Sectional Garage Door", dated 01/19/2001, with last revision J dated 03/21/2016, sheets 1 through 5 of 5, prepared by Al-Farooq Corporation, signed and sealed by Javad Ahmad, P.E., bearing the Miami-Dade County Product Control renewal stamp with the Notice of Acceptance number and expiration date by the Miami-Dade County Product Control Section.

MISSILE IMPACT RATING: Large and Small Missile Impact Resistant

LABELING: A permanent label with the manufacturer's name or logo, manufacturing address, model number, the positive and negative design pressure rating, indicate impact rated if applicable, installation instruction drawing reference number, approval number (NOA), the applicable test standards, and the statement reading 'Miami-Dade County Product Control Approved' is to be located on the door's side track, bottom angle, or inner surface of a panel.

RENEWAL of this NOA shall be considered after a renewal application has been filed and there has been no change in the applicable building code negatively affecting the performance of this product.

TERMINATION of this NOA will occur after the expiration date or if there has been a revision or change in the materials, use, and/or manufacture of the product or process. Misuse of this NOA as an endorsement of any product, for sales, advertising or any other purposes shall automatically terminate this NOA. Failure to comply with any section of this NOA shall be cause for termination and removal of NOA.

ADVERTISEMENT: The NOA number preceded by the words Miami-Dade County, Florida, and followed by the expiration date may be displayed in advertising literature. If any portion of the NOA is displayed, then it shall be done in its entirety.

INSPECTION: A copy of this entire NOA shall be provided to the user by the manufacturer or its distributors and shall be available for inspection at the job site at the request of the Building Official.

This NOA **renews NOA # 15-0317.04** and consists of this page 1 and evidence pages E-1 and E-2, as well as approval document mentioned above.

The submitted documentation was reviewed by **Carlos M. Utrera, P.E.**



Handwritten signature and date: 06/29/2016

NOA No. 16-0330.04
 Expiration Date: October 4, 2021
 Approval Date: June 23, 2016
 Page 1

NOTICE OF ACCEPTANCE: EVIDENCE SUBMITTED

A. DRAWINGS

1. Drawing No. **01-05**, titled "Sectional Garage Door", dated 01/19/2001, with last revision J dated 03/21/2016, sheets 1 through 5 of 5, prepared by Al-Farooq Corporation, signed and sealed by Javad Ahmad, P.E.

B. TESTS "*Submitted under NOA # 09-0128.05*"

1. Test report of Tensile Test per ASTM E 8, Report No. **HETI 08-T182**, prepared by Hurricane Engineering & Testing, Inc., dated 12/23/2008, signed and sealed by Candido F. Font, P.E.

"Submitted under NOA # 08-1106.05"

2. Test reports on 1) Uniform Static Air Pressure Test Loading per FBC TAS 202-94
2) Large Missile Impact Test per FBC, TAS 201-94
3) Cyclic Wind Pressure Loading per FBC, TAS 203-94
4) Forced Entry Test per FBC 2411 3.2.1, TAS 202-94
along with marked-up drawings and installation diagram of a DAB 824 24 GA Sectional Garage Door with Fixed Windows, prepared by Hurricane Engineering & Testing, Inc, Test Reports No. **HETI-08-2149A/B**, dated 06/27/2008, signed and sealed by Candido F. Font, P.E.

"Submitted under NOA # 03-0210.04"

3. Test report on Salt Spray (Corrosion) Test per ASTM B 117 of a painted G-40 steel panels, prepared by Celotex Corporation, Test Report No. **258592**, dated 08/17/1998, signed by W. A. Jackson, P.E.

"Submitted under NOA # 01-0620.08"

4. Test report of Uniform Static Air Pressure and Force Entry Resistance Test, per FBC, TAS 202-94 on "Sectional Residential Garage Doors", prepared by Hurricane Engineering & Testing, Inc., Report No. **HETI 01-966**, dated 01/18/2001, signed and sealed by Hector M. Medina, P.E.
5. Test report of Large Missile Impact Test, per FBC, TAS 201-94 and Cyclic Wind Pressure Test per, per FBC, TAS 203-94 on "Sectional Residential Garage Doors", prepared by Hurricane Engineering & Testing, Inc., Report No. **HETI 01-972/974**, dated 01/29/2001, signed and sealed by Hector M. Medina, P.E.

C. CALCULATIONS "*Submitted under NOA # 14-0814.09*"

1. Anchor verification calculations prepared by Al-Farooq Corporation, dated 09/22/2014 and 07/24/2014, signed and sealed by Javad Ahmad, P.E.

06/29/2016

Carlos M. Utrera, P.E.
Product Control Examiner
NOA No. 16-0330.04
Expiration Date: October 4, 2021
Approval Date: June 23, 2016

NOTICE OF ACCEPTANCE: EVIDENCE SUBMITTED

C. CALCULATIONS (Cont.)

“Submitted under NOA # 09-0128.05”

1. Anchor verification calculations prepared by Al-Farooq Corporation, complying with F.B.C 2007, dated 12/19/2008, signed and sealed by Humayoun Farooq, P.E.

D. QUALITY ASSURANCE

1. Miami-Dade Department of Regulatory and Economic Resources (RER)

E. MATERIAL CERTIFICATIONS

1. Notice of Acceptance No. **15-0915.08**, issued to SABIC Innovative Plastics, for their Lexan Polycarbonate Sheet Products, approved on 12/10/2015 and expiring on 07/17/2018.
2. Notice of Acceptance No. **14-0311.08**, issued to Insulfoam, LLC, for their Insulfoam Expanded Polystyrene Insulation, approved on 08/14/2014 and expiring on 11/29/2017.
3. Notice of Acceptance No. **11-0926.07**, issued to Dyplast Products, LLC, for their Expanded Polystyrene Block Type Insulation, approved on 11/10/2011 and expiring on 01/11/2017.
4. Notice of Acceptance No. **11-0926.06**, issued to Dyplast Products, LLC, for their Dyplast ISO-C1 Polyisocyanurate Insulation, approved on 11/10/2011 and expiring on 01/11/2017.
5. Notice of Acceptance No. **15-1203.04**, issued to Cellofoam North America Inc, for their Expanded Polystyrene Block Insulation, approved on 03/17/2016 and expiring on 02/24/2021.

“Submitted under NOA # 05-0228.02”

6. Test Report on Accelerated Weathering Using Xenon Arc Light Apparatus Test per ASTM G155 of “PVC Extrusion Material”, prepared by Hurricane Engineering & Testing, Inc., Report No. **HETI 04-A002**, dated 09/27/2004, signed and sealed by Rafael E. Droz-Seda, P.E.
7. Test Reports on Tensile Test per ASTM D638 of “PVC Extrusion Material”, prepared by Hurricane Engineering & Testing Inc., Report No. **HETI 04-T251**, dated 11/29/2004 signed and sealed by I. Ghia, P.E.
8. Test Report on Self-Ignition Temperature Test, Rate of Burn Test and Smoke Density Test of “REHAU non-foam PVC extrusion material”, prepared by ETC Laboratories, Report No. **04-761-15019.0**, dated 05/06/2004, signed and sealed by J. L. Doldan, P.E.

F. STATEMENTS

1. Statement letter of code conformance to the 5th edition (2014) FBC and of no financial interest issued by Al-Farooq Corporation, dated 03/21/2016, signed and sealed by Javad Ahmad, P.E.



Carlos M. Utrera, P.E.

Product Control Examiner

NOA No. 16-0330.04

Expiration Date: October 4, 2021

Approval Date: June 23, 2016

no.	date	description
G	09.16.14	NO CHANGE THIS SHEET
H	11.07.14	NO CHANGE THIS SHEET
J	03.09.15	NO CHANGE THIS SHEET
J	03.21.16	NO CHANGE THIS SHEET

revisions: 01-19-01

date:	scale: 1/2"=1'-0"
dr. by: HAMID	chk. by:

drawing no. 01-05
 sheet 1 of 5

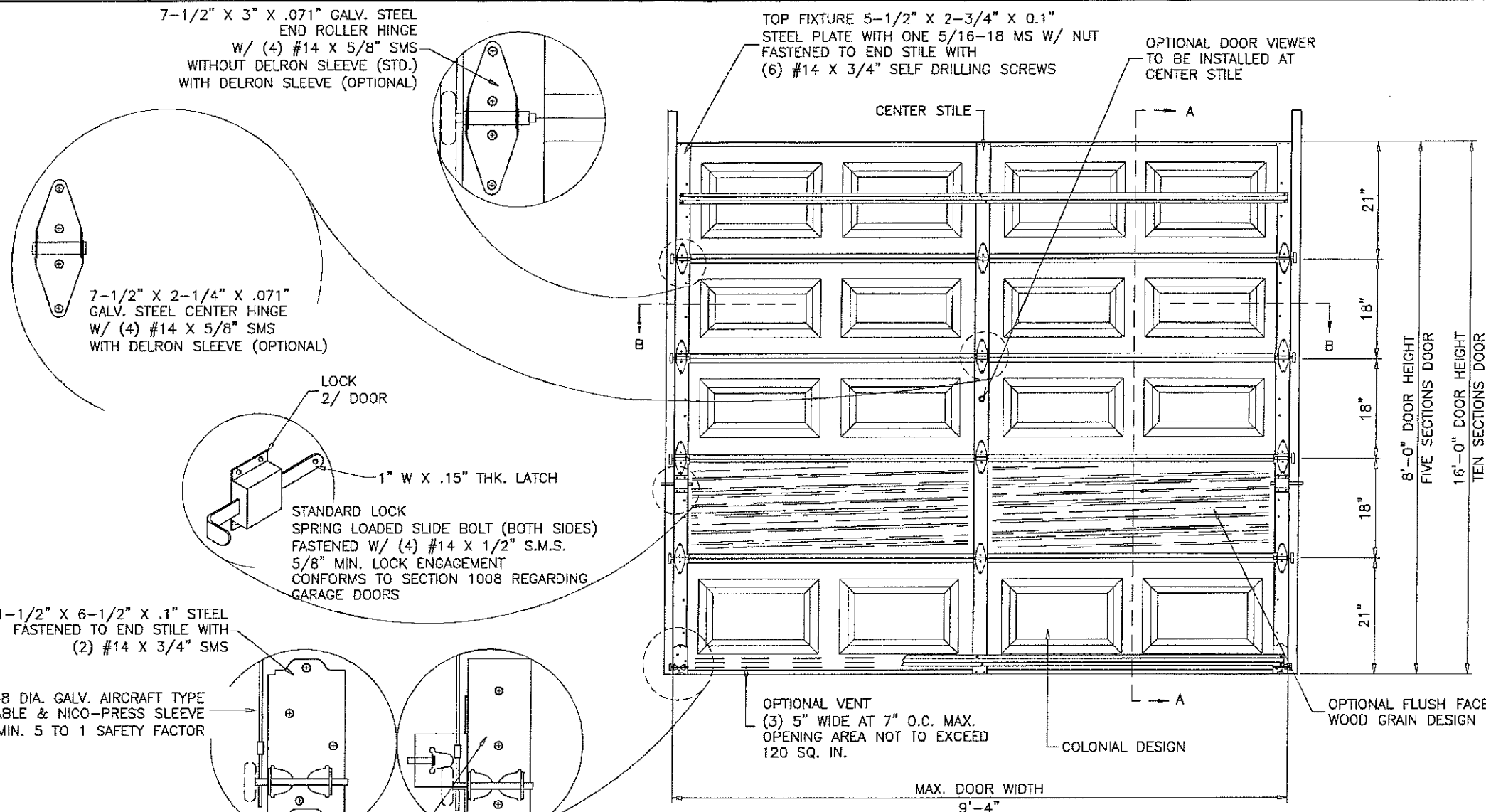

#14 X 3/4" SELF DRILLING SCREWS MAY BE USED IN LIEU OF #14 X 5/8" SMS

DOOR HEIGHT	CONSISTS OF		TOTAL # OF 'U' BARS AT EACH DOOR
6'-6"	2 SECTIONS 18"	2 SECTIONS 21"	2 'U' BARS ALL DOORS
6'-9"	1 SECTION 18"	3 SECTIONS 21"	
7'	4 SECTIONS 21"	-	
7'-3"	-	-	
7'-6"	5 SECTIONS 18"	-	
7'-9"	4 SECTIONS 18"	1 SECTION 21"	
8'	3 SECTIONS 18"	2 SECTIONS 21"	
8'-3"	2 SECTIONS 18"	3 SECTIONS 21"	
8'-6"	1 SECTION 18"	4 SECTIONS 21"	
8'-9"	5 SECTIONS 21"	-	
9'	6 SECTIONS 18"	-	
9'-3"	5 SECTIONS 18"	1 SECTION 21"	
9'-6"	4 SECTIONS 18"	2 SECTIONS 21"	
9'-9"	3 SECTIONS 18"	3 SECTIONS 21"	
10'	2 SECTIONS 18"	4 SECTIONS 21"	
10'-3"	1 SECTION 18"	5 SECTIONS 21"	
10'-6"	6 SECTIONS 21"	-	
10'-9"	6 SECTIONS 18"	1 SECTION 21"	
11'	5 SECTIONS 18"	2 SECTIONS 21"	
11'-3"	4 SECTIONS 18"	3 SECTIONS 21"	
11'-6"	3 SECTIONS 18"	4 SECTIONS 21"	
11'-9"	2 SECTIONS 18"	5 SECTIONS 21"	
12'	1 SECTION 18"	6 SECTIONS 21"	
12'-3"	7 SECTIONS 21"	-	
12'-6"	6 SECTIONS 18"	2 SECTIONS 21"	
12'-9"	5 SECTIONS 18"	3 SECTIONS 21"	
13'	4 SECTIONS 18"	4 SECTIONS 21"	
13'-3"	3 SECTIONS 18"	5 SECTIONS 21"	
13'-6"	2 SECTIONS 18"	6 SECTIONS 21"	
13'-9"	1 SECTION 18"	7 SECTIONS 21"	
14'	8 SECTIONS 21"	-	
14'-3"	6 SECTIONS 18"	3 SECTIONS 21"	
14'-6"	5 SECTIONS 18"	4 SECTIONS 21"	
14'-9"	4 SECTIONS 18"	5 SECTIONS 21"	
15'	3 SECTIONS 18"	6 SECTIONS 21"	
15'-3"	2 SECTIONS 18"	7 SECTIONS 21"	
15'-6"	1 SECTION 18"	8 SECTIONS 21"	
15'-9"	9 SECTIONS 21"	-	
16'	6 SECTIONS 18"	4 SECTIONS 21"	

3" X 1-1/2" X 6-1/2" X .1" STEEL FASTENED TO END STILE WITH (2) #14 X 3/4" SMS

.158 DIA. GALV. AIRCRAFT TYPE CABLE & NICO-PRESS SLEEVE W/ MIN. 5 TO 1 SAFETY FACTOR

7-7/8" X 3-1/8" X .010" STEEL PLATE WITH (4) #14 X 3/4" SDS

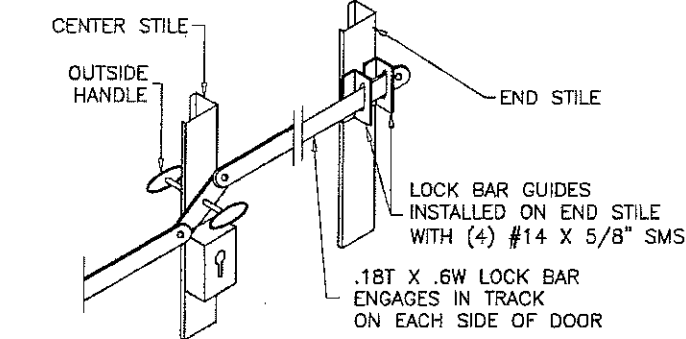

OUTSIDE KEYPED LOCK (OPTIONAL)
 LOCK BAR LOCKING SHOWN ALTERNATE TO SPRING LOADED SLIDE BOLT LOCKS SHOWN ABOVE

MAXIMUM DESIGN LOAD RATING = + 62.0 PSF (DOORS WITHOUT WINDOWS)
 - 70.0 PSF

DOOR TESTED IN ACCORDANCE WITH THE REQUIREMENTS OF FLORIDA BUILDING CODE, TAS-202, TAS-201 & TAS-203 FOR HVHZ.

MAXIMUM DESIGN LOAD RATING = + 55.0 PSF (DOORS WITH WINDOWS)
 - 64.0 PSF

DOOR TESTED IN ACCORDANCE WITH THE REQUIREMENTS OF FLORIDA BUILDING CODE, TAS-202, TAS-201 & TAS-203 FOR HVHZ AND ASTM E1886-05/ASTM E1996-09.

THIS PRODUCT IS RATED FOR LARGE MISSILE IMPACT

GENERAL NOTES

1. THIS PRODUCT HAS BEEN DESIGNED AND TESTED TO COMPLY WITH THE REQUIREMENTS OF THE 2014 (5TH EDITION) FLORIDA BUILDING CODE INCLUDING HIGH VELOCITY HURRICANE ZONE (HVHZ).
2. ANCHORS SHALL BE AS LISTED, SPACED AS SHOWN ON DETAILS. ANCHOR EMBEDMENT TO BASE MATERIAL SHALL BE BEYOND WALL DRESSING OR STUCCO.
3. ALL BOLTS, NUTS AND WASHERS SHALL BE ZINC PLATED CARBON STEEL.
4. ANCHORING OR LOADING CONDITIONS OTHER THAN THOSE SHOWN IN THESE DETAILS ARE NOT PART OF THIS APPROVAL.
5. A LOAD DURATION INCREASE IS USED IN DESIGN OF ANCHORS INTO WOOD ONLY.

PRODUCT RENEWED
 as complying with the Florida Building Code
 NOA-No. 16-0330.04
 Expiration Date 10/04/2021
 By *[Signature]*
 Miami-Dade Product Control

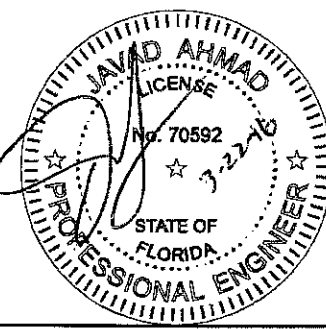

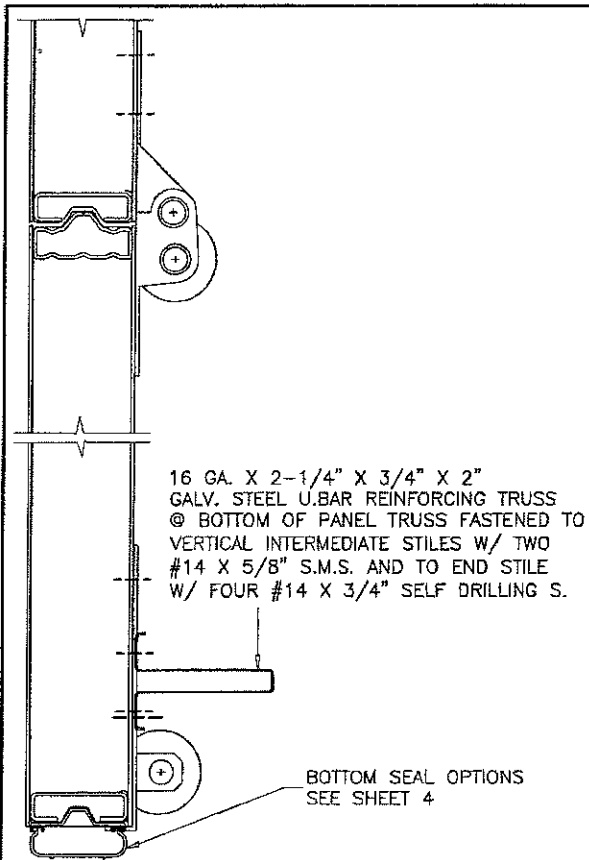

BOTTOM SECTION
REINFORCING TRUSS
ONE AT BOTTOM PANEL

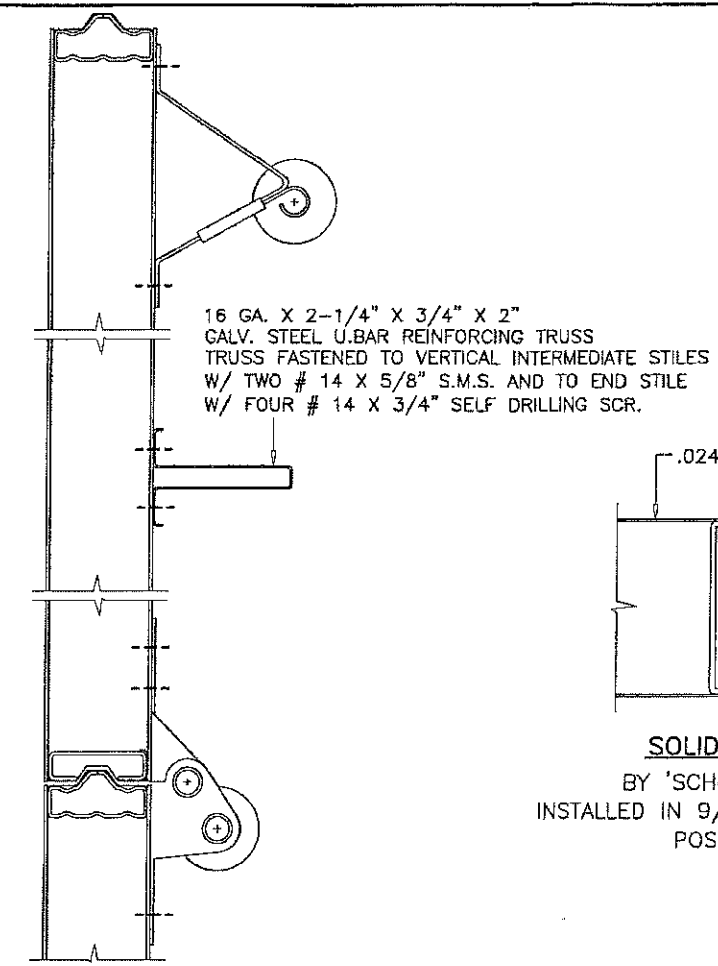

TOP SECTION
REINFORCING TRUSS
ONE AT TOP PANEL

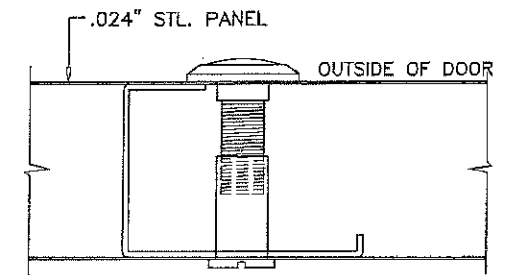

SOLID BRASS DOOR VIEWER
BY 'SCHLAGE SECURITY HARDWARE'
INSTALLED IN 9/16" DIA. HOLES IN CENTER STILE
POSITIONED AT EYE LEVEL

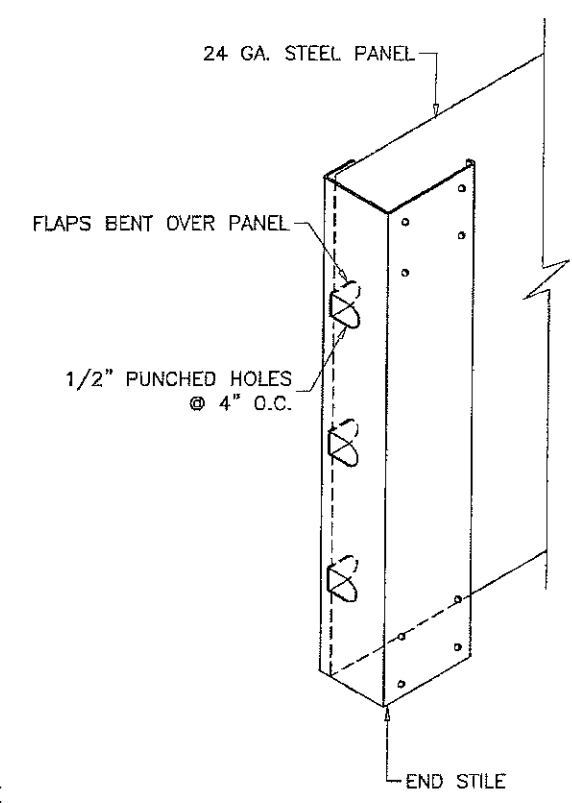

- ANCHORS AT TRACK BRACKET:**
- A) 3/8" DIA. POWER-BOLT BY 'POWERS'
2" MIN. EMBED INTO CONCRETE
1-7/8" MIN. EDGE DISTANCE
 - B) 3/8" DIA. HLC SLEEVE BY 'HULTI'
1-1/4" MIN. EMBED INTO CONCRETE OR FILLED BLOCK
1-5/8" MIN. EDGE DISTANCE INTO CONCRETE
4" MIN. EDGE DISTANCE INTO FILLED BLOCK

CONCRETE f'c = 3000 PSI MIN.
C-90 GROUT FILLED BLOCK f'm = 2000 PSI MIN.

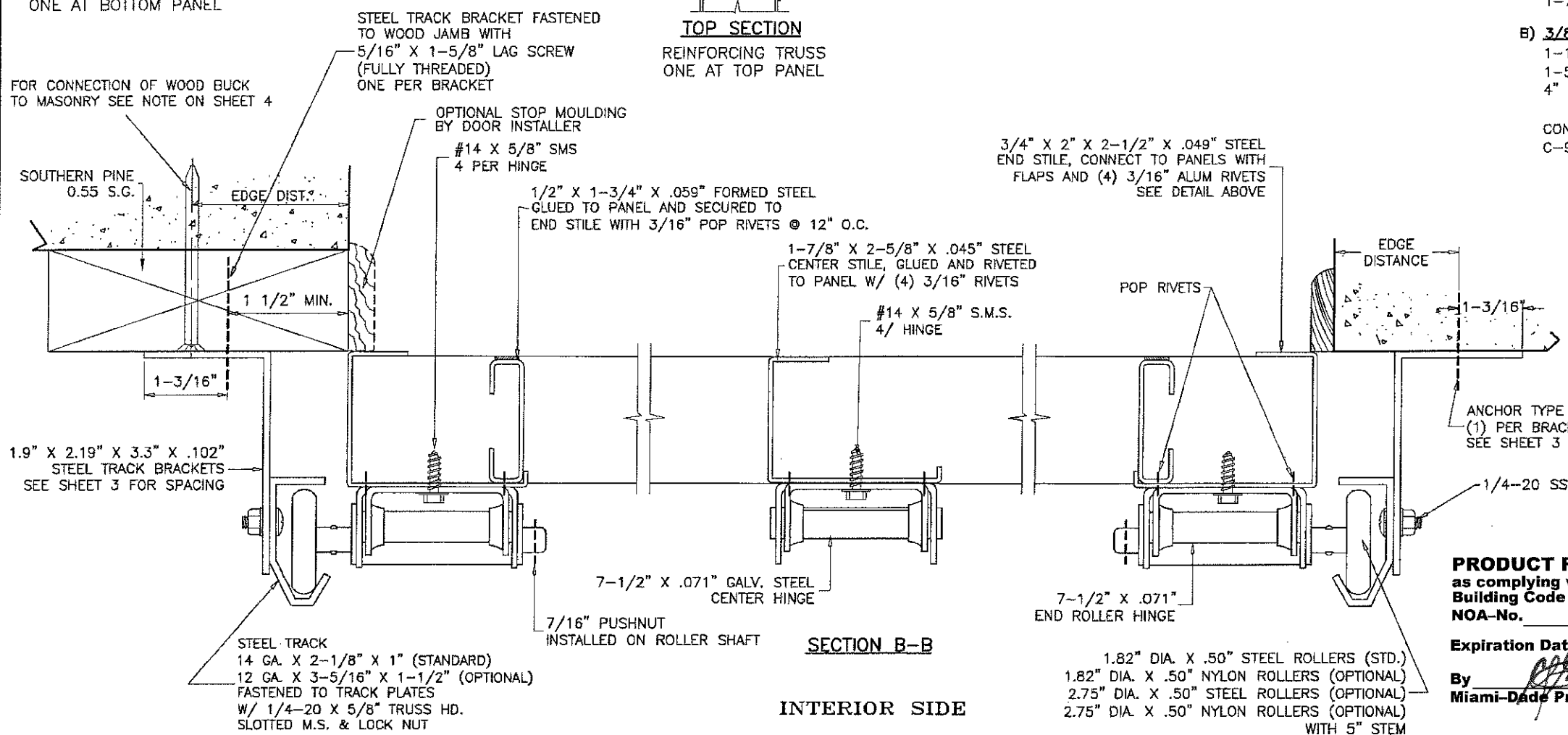

SECTION B-B
INTERIOR SIDE

PRODUCT RENEWED
as complying with the Florida
Building Code
NOA-No. **16-0330.04**
Expiration Date **10/04/2021**
By *[Signature]*
Miami-Dade Product Control

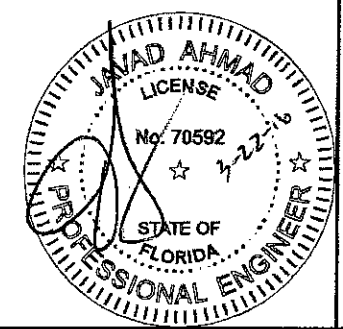

af c

AL-FAROOQ CORPORATION
ENGINEERS & PRODUCT DEVELOPMENT
9360 SUNSET DRIVE, SUITE 220
MIAMI, FLORIDA 33173 (C.A.N. 353B)
TEL. (305) 264-8100 FAX. (305) 262-6978

SECTIONAL GARAGE DOOR

DAB DOORS INC.
12195 N.W. 98 TH. AVE.
HIALEAH GARDENS, FL. 33018
TEL. (305) 556 - 6824

NO	DATE	DESCRIPTION
G	09.16.14	NO CHANGE THIS SHEET
H	11.07.14	NO CHANGE THIS SHEET
I	03.09.15	BOTTOM SEAL OPTION ADDED
J	03.21.16	NO CHANGE THIS SHEET

date: 01-19-01
scale: -
dr. by: HAMID
chk. by:

drawing no.
01-05

sheet 2 of 5

GARAGE\01-05DAB

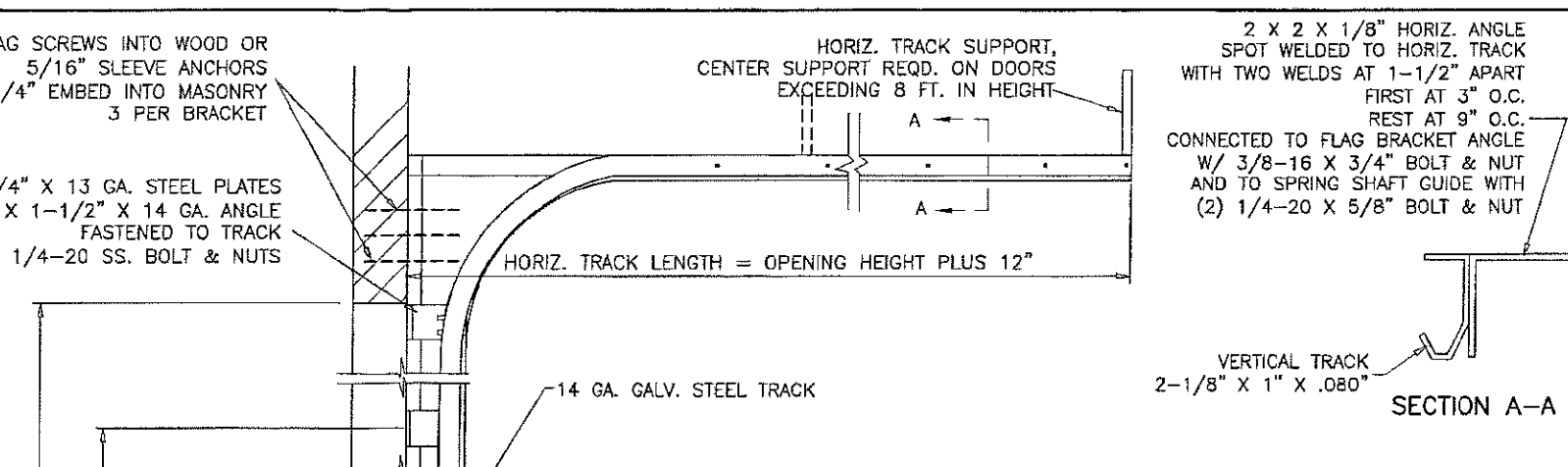
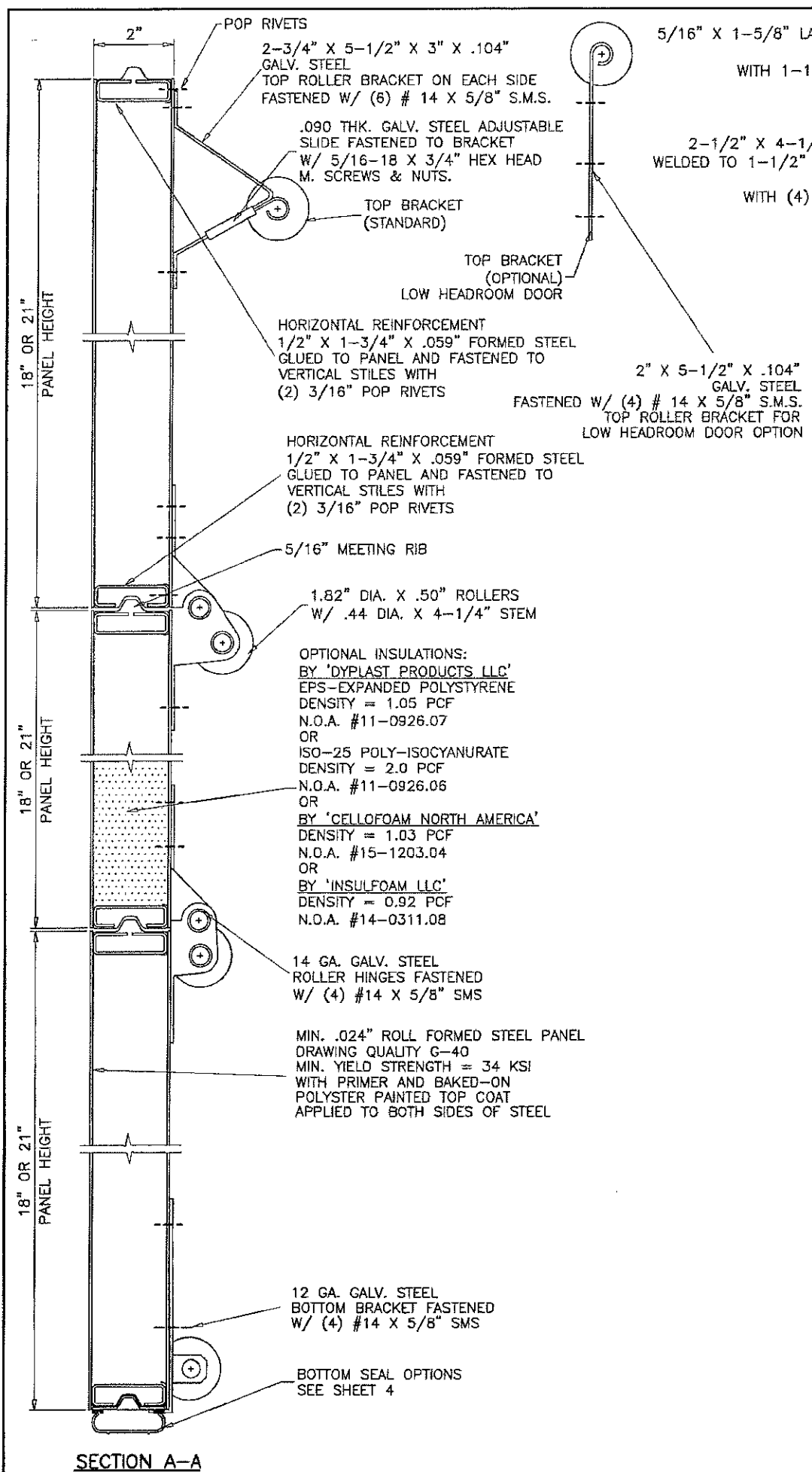

DOOR HEIGHT	* SECTION HEIGHTS					BRACKET PLACEMENTS							
	1ST	2ND	3RD	4TH	5TH	B1	B2	B3	B4	B5	B6	B7	B8
6'-0"	18"	18"	18"	18"	N/A	1" TO 2"	11-3/4"	23"	34"	45"	56"	67"	-
6'-6"	21"	18"	18"	21"	N/A	1" TO 2"	11-3/4"	23"	34"	45"	56"	67"	-
7'-0"	21"	21"	21"	21"	N/A	1" TO 2"	11-3/4"	23"	34"	45"	56"	67"	-
7'-6"	18"	18"	18"	18"	18"	1" TO 2"	11-3/4"	23"	34"	45"	56"	67"	78-1/4"
8'-0"	21"	18"	18"	18"	21"	1" TO 2"	11-3/4"	23"	34"	45"	56"	67"	78-1/4"

*-SECTIONS ARE NUMBERED STARTING AT THE BOTTOM FOR DOORS MORE THAN 8 FT. HIGH, USE ADDITIONAL TRACK BRACKETS AT 10" O.C.

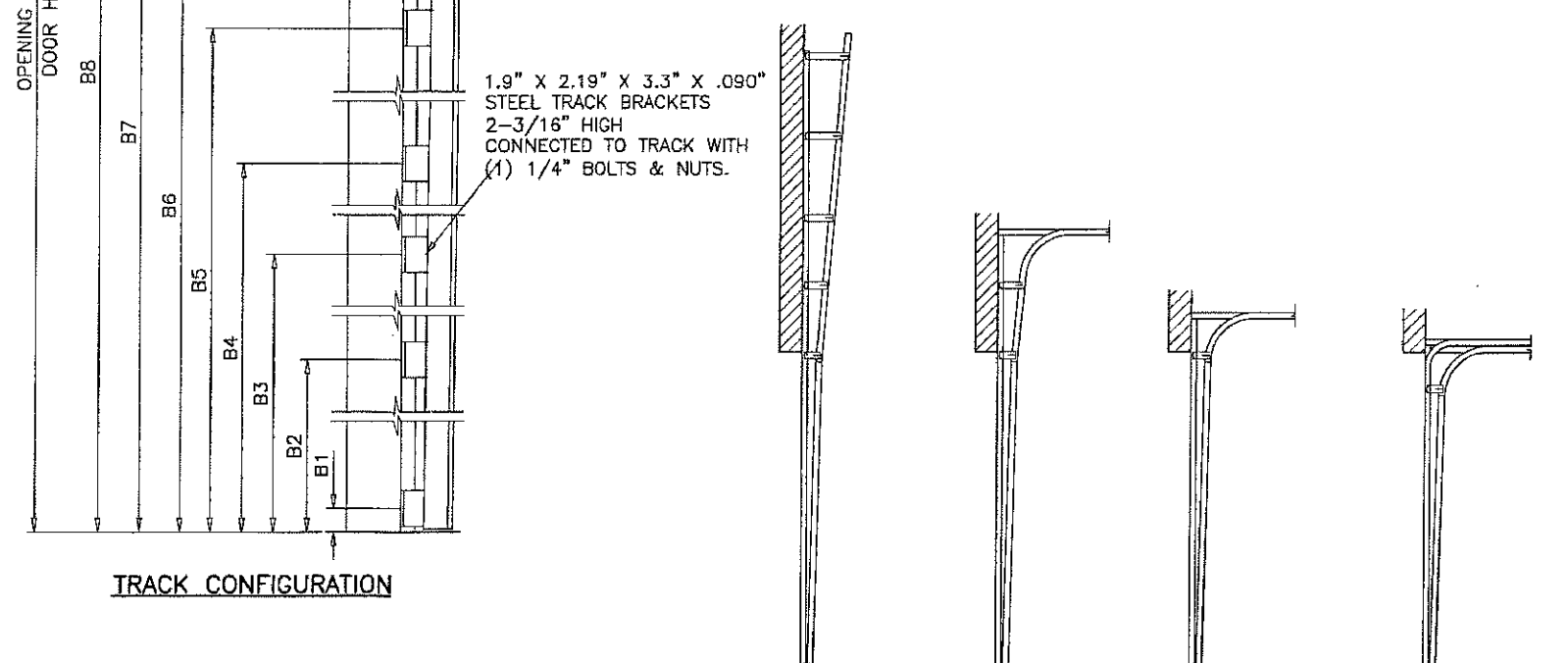

AVAILABLE TRACK OPTIONS

PRODUCT RENEWED
 as complying with the Florida Building Code
 NOA-No. **16-0330.04**
 Expiration Date **10/04/2021**
 By *[Signature]*
 Miami-Dade Product Control

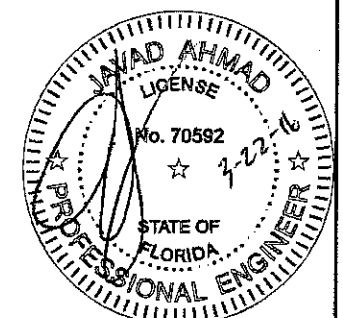

AL-FAROOQ CORPORATION
 ENGINEERS & PRODUCT DEVELOPMENT
 9360 SUNSET DRIVE, SUITE 220
 MIAMI, FLORIDA 33173
 TEL. (305) 264-8100 FAX. (305) 262-6978
 GARAGE/01-05DAB

SECTIONAL GARAGE DOOR
DAB DOORS INC.
 12195 N.W. 98 TH. AVE.
 HIALEAH GARDENS, FL. 33018
 TEL. (305) 556 - 6824

no	date	by	description
G	09.16.14		FOAM NOA REV.
H	11.07.14		NO CHANGE THIS SHEET
I	03.09.15		BOTTOM SEAL OPTION ADDED
J	03.21.16		INSULATION UPDATED

revisions:

date: 01-19-01
 scale: -
 dr. by: HAMID
 chk. by:

drawing no. **01-05**
 sheet 3 of 5

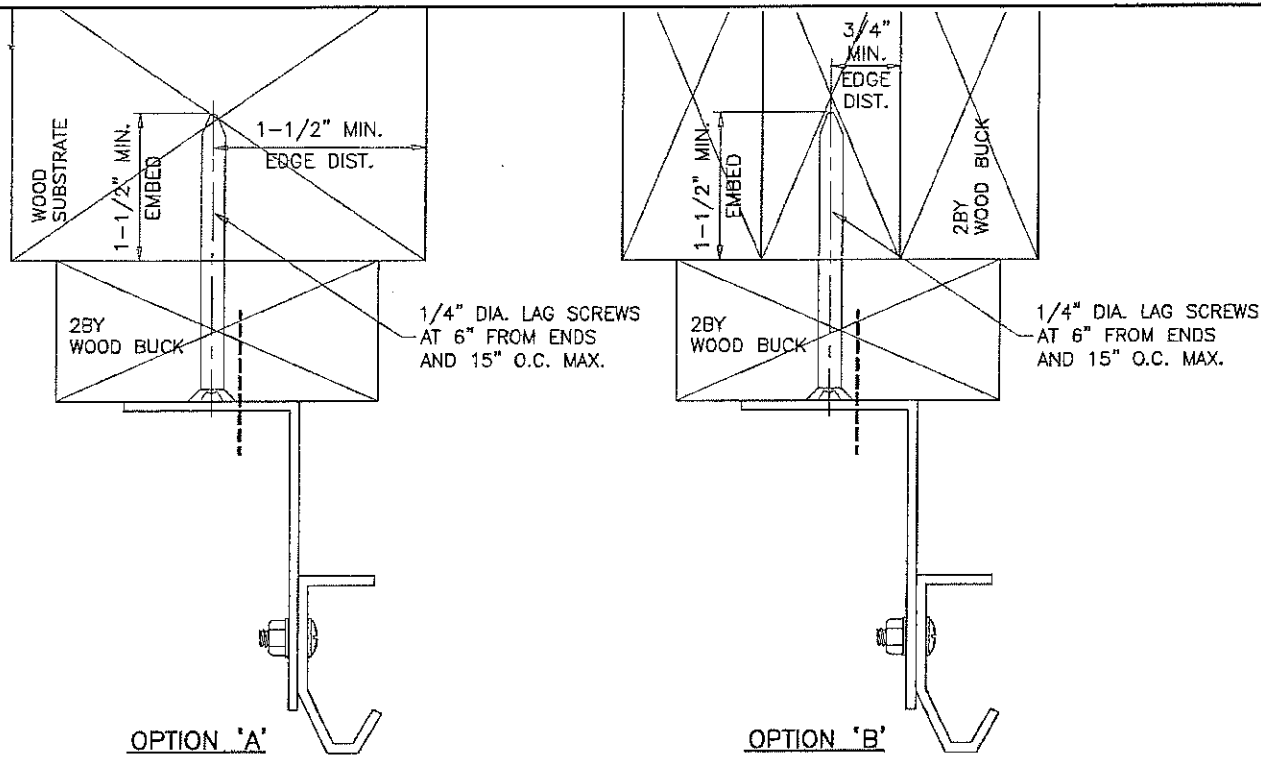

WOOD BUCK CONNECTION TO WOOD SUBSTRATE (WOOD SPECIFIC GRAVITY SG=0.55 MIN.)

THE INSTALLATION METHODS SHOWN ABOVE SHOWS 2X6 SYP WOOD BUCK ATTACHMENT TO WOOD STRUCTURES. IF THESE METHODS ARE FOLLOWED NO ADDITIONAL CALCULATIONS/DESIGN WILL BE REQUIRED FOR DESIGN OF GARAGE DOOR ANCHORAGE. FOR DOOR REPLACEMENT APPLICATIONS WITH NO ENGINEER OF RECORD, INSTALLATION MAY BE VERIFIED AND APPROVED BY THE BUILDING OFFICIAL UPON INSPECTION.

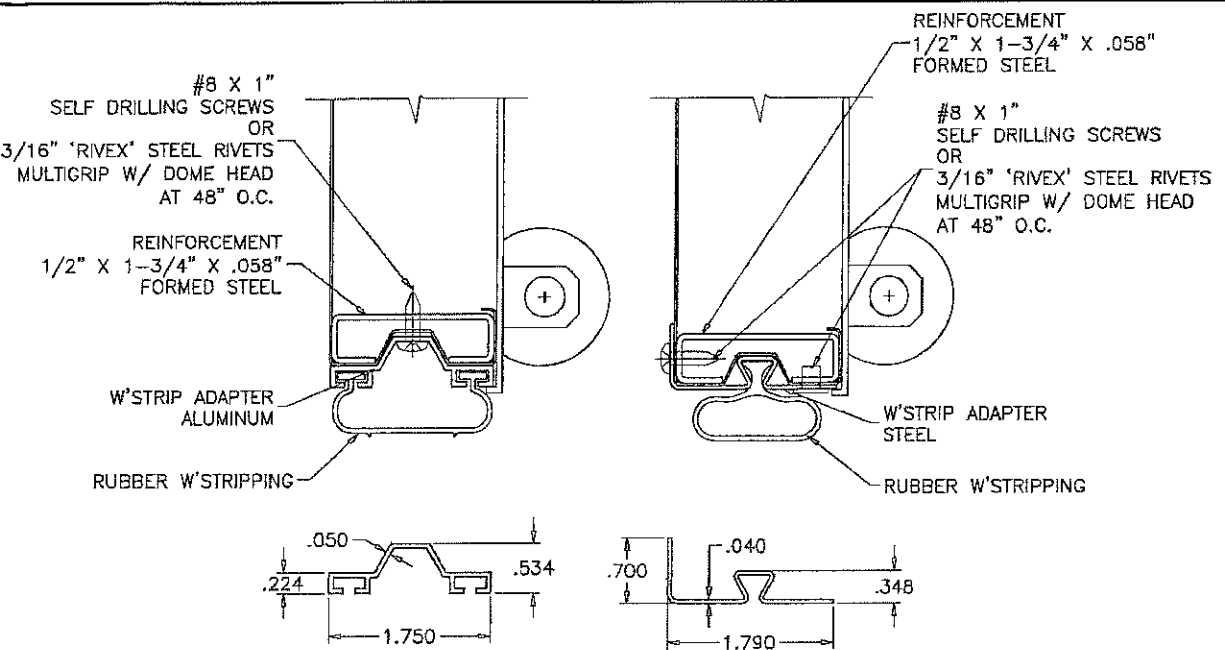

BOTTOM SEAL OPTIONS

ANCHOR SPACING				
ANCHORS	STRUCTURE	EMBED	SPACING	EDGE DIST.
3/8" HLC SLEEVE BY 'HILTI'	CONC.	1-1/4"	8"	2"
3/8" HLC SLEEVE BY 'HILTI'	FILLED BLOCK	1-1/4"	8"	4"
3/8" DYNABOLT BY 'ITW'	CONC.	1-1/2"	8"	2-1/2"
3/8" CONFLX BY 'ELCO'	FILLED BLOCK	2"	8"	3-3/4"
3/8" POWER-BOLT BY 'POWERS'	CONC.	2"	8"	1-7/8"
3/8" SLEEVE-ALL BY 'SIMPSONS'	CONC.	1-1/2"	8"	1-7/8"

CONCRETE f'c = 3000 PSI MIN.
C-90 GROUT FILLED BLOCK f'm = 2000 PSI MIN.

WOOD BUCK CONNECTION TO MASONRY

PRESSURE TREATED 2X6 SYP WOOD BUCKS SHALL BE ANCHORED TO GROUTED REINFORCED MASONRY BLOCK WALL OR CONC. COLUMN WITH

1/4" ULTRACON BY 'ELCO' WITH SPACING OF 16" O.C. INTO GROUT FILLED BLOCK WALL, WITH 2-1/4" MIN. EMBED 12" O.C. INTO 3000 PSI CONCRETE, WITH 1-3/4" MIN. EMBED 2-1/2" MIN. EDGE DISTANCE

1/4" TAPPER BY 'POWERS' WITH SPACING OF 11" O.C. INTO GROUT FILLED BLOCK WALL, WITH 1-1/2" MIN. EMBED 11" O.C. INTO 3000 PSI CONCRETE, WITH 1-3/4" MIN. EMBED 3" MIN. EDGE DISTANCE

3/8" CONFLX BY 'ELCO' OR 3/8" LDT BY 'ITW' WITH SPACING OF 23" O.C. INTO 3000 PSI CONCRETE, WITH 2-1/2" MIN. EMBED 3" MIN. EDGE DISTANCE

3/8" HLC SLEEVE BY 'HILTI' WITH SPACING OF 8" O.C. INTO GROUT FILLED BLOCK WALL, WITH 1-1/4" MIN. EMBED, 4" MIN. EDGE DIST. 15" O.C. INTO 3000 PSI CONCRETE, WITH 1-1/4" MIN. EMBED AND 2-1/2" MIN. EDGE DISTANCE

PREPARATION OF JAMBS BY OTHERS

FOR NEW CONSTRUCTION ENGINEER OF RECORD OR ARCHITECT TO VERIFY ADEQUACY OF SUPPORTING STRUCTURE TO SUPPORT LOADS IMPOSED BY DOOR SYSTEM.

FOR DOOR REPLACEMENT IN RETROFIT BUILDINGS WITH NO ENGINEER OF RECORD, DOOR INSTALLATION MAY BE REVIEWED AND APPROVED BY BUILDING OFFICIAL UPON INSPECTION.

MAXIMUM EXTERIOR(+) LOAD PER JAMB = (9.33' X 62 PSF)/2 = 289.3 Lbs per Ft.
MAXIMUM INTERIOR(-) LOAD PER JAMB = (9.33' X 70 PSF)/2 = 326.5 Lbs per Ft.

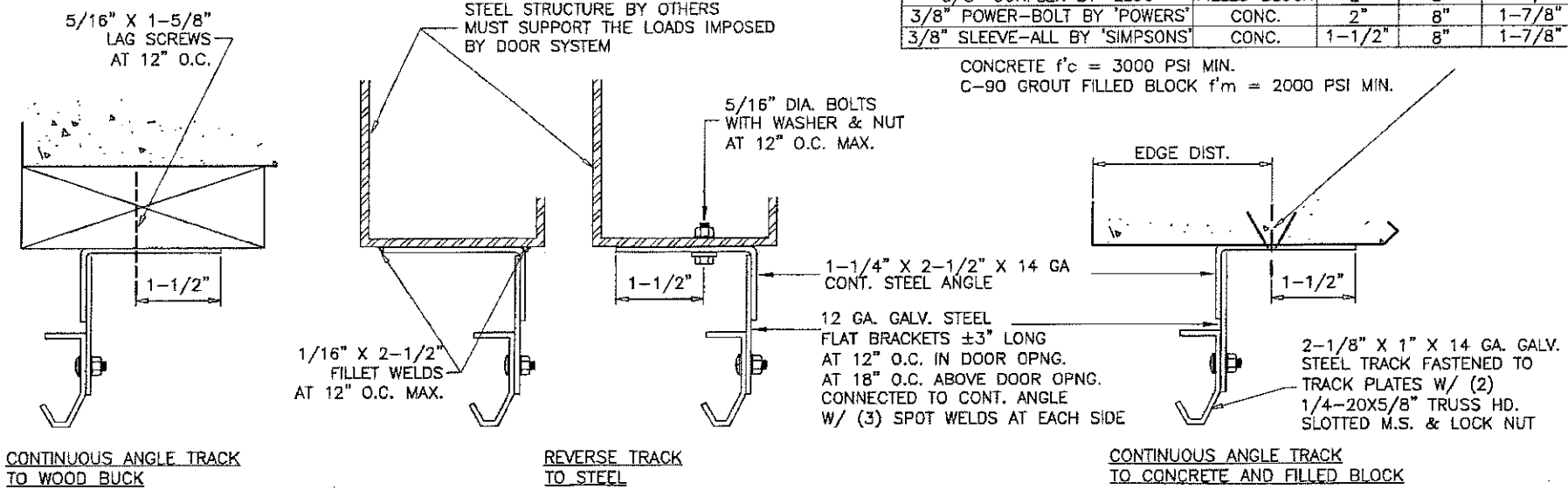

ALTERNATE TRACK INSTALLATION

PRODUCT RENEWED
as complying with the Florida Building Code
NOA-No. 16-0330.04

Expiration Date 10/04/2021

By *[Signature]*
Miami-Dade Product Control

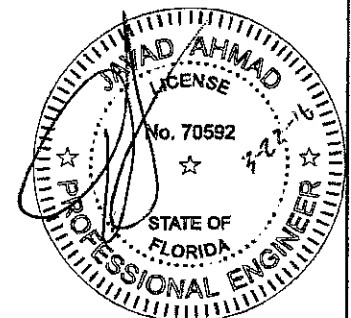

SECTIONAL GARAGE DOOR
DAB DOORS INC.
12195 N.W. 98 TH. AVE.
HIALEAH GARDENS, FL. 33018
TEL (305) 556 - 6624

NO	DATE	BY	DESCRIPTION
G	09.16.14		ANCHORS REVISED
H	11.07.14		REV. PER RER COMMENTS
I	03.09.15		BOTTOM SEAL OPTION ADDED
J	03.21.16		NO CHANGE THIS SHEET

date: 01-19-01
scale: -
dr. by: HAMID
chk. by:
drawing no. 01-05
sheet 4 of 5

af c
AL-FAROOQ CORPORATION
ENGINEERS & PRODUCT DEVELOPMENT
9360 SUNSET DRIVE, SUITE 220
MIAMI, FLORIDA 33173
TEL. (305) 264-8100 FAX. (305) 262-6978
(C.A.N. 3638)

GARAGE_01-05DAB

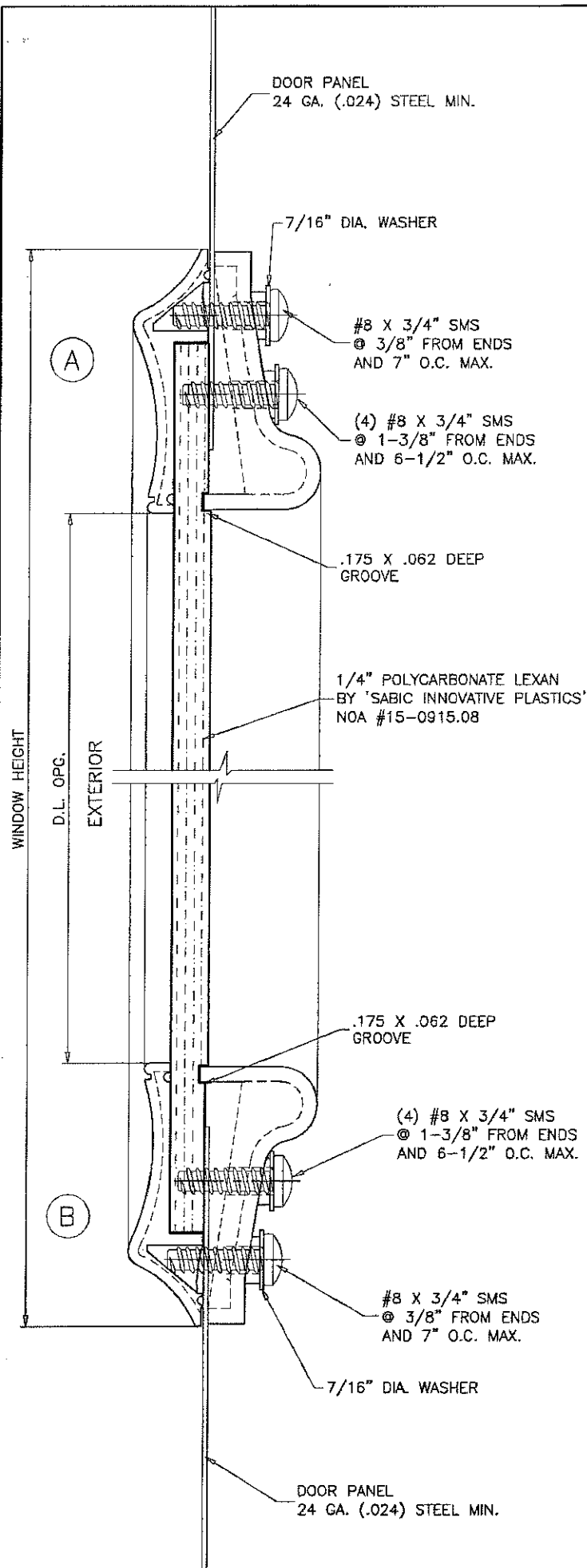

* PLASTIC COMPLIES WITH CHAPTER 26 OF FBC SEE EVIDENCE PAGE

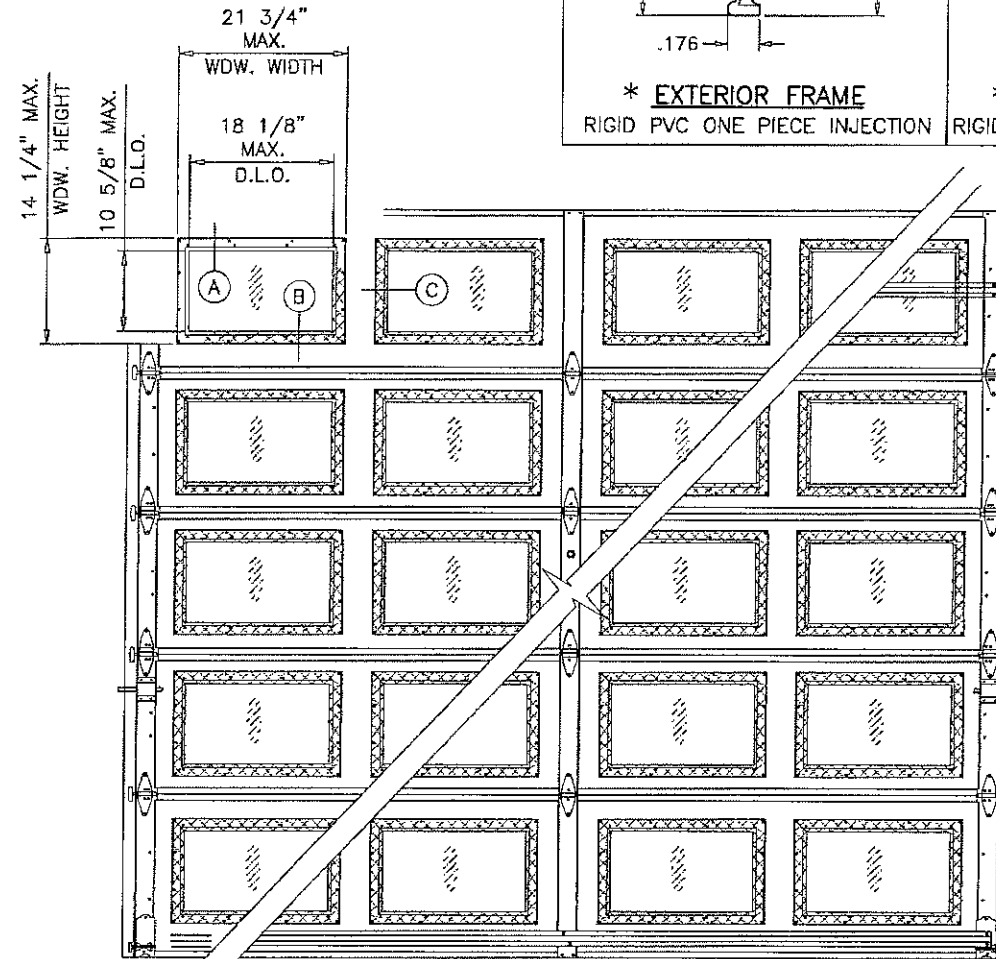
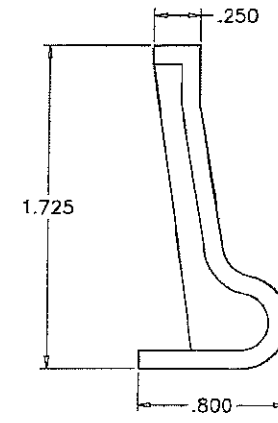
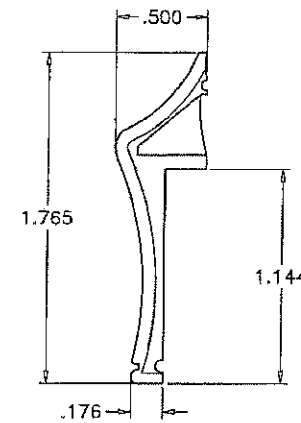

INSIDE ELEVATION

RAISED PANEL EMBOSSED DOOR WITH OPTIONAL WINDOWS
WINDOW LITES CAN BE IN ANY LOCATION IN DOOR SECTION

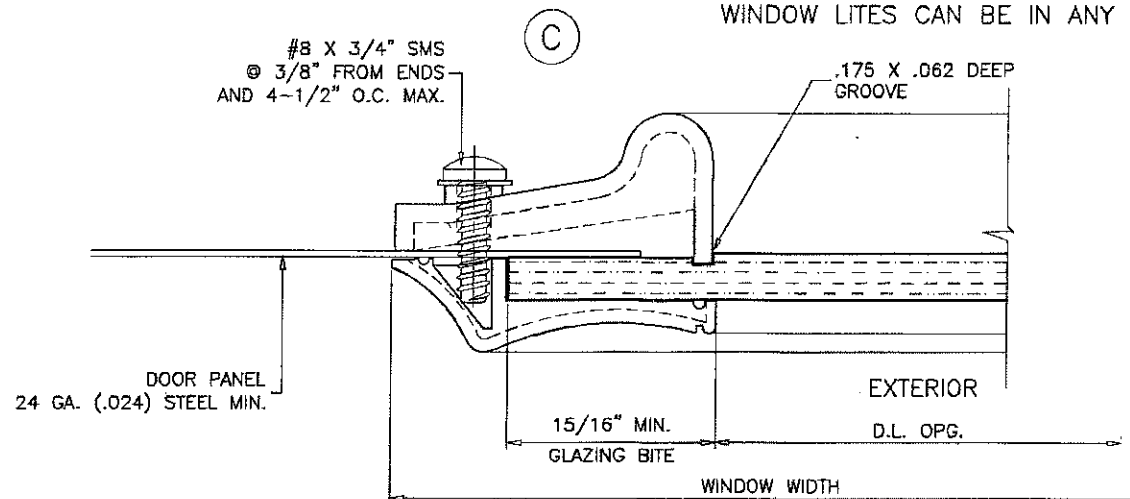

PRODUCT RENEWED
as complying with the Florida Building Code
NOA-No. **16-0330.04**
Expiration Date **10/04/2021**
By *[Signature]*
Miami-Dade Product Control

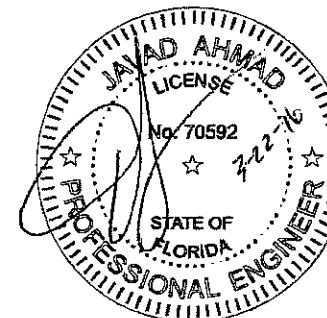

af c
AL-FAROOQ CORPORATION
ENGINEERS & PRODUCT DEVELOPMENT
9360 SUNSET DRIVE, SUITE 220
MIAMI, FLORIDA 33173 (C.A.N. 3538)
TEL. (305) 264-8100 FAX. (305) 262-6978
GARAGE\01-05DAB

SECTIONAL GARAGE DOOR
DAB DOORS INC.
12195 N.W. 98 TH. AVE.
HIALEAH GARDENS, FL. 33018
TEL. (305) 556 - 6624

revisions:	
no.	description
G	09.16.14 NO CHANGE THIS SHEET
H	11.07.14 REV. PER RER COMMENTS
I	03.09.15 NO CHANGE THIS SHEET
J	03.21.16 LEXAN UPDATED

date:	01-19-01
scale:	-
dr. by:	HAMID
chk. by:	

drawing no.	01-05
sheet	5 of 5