



DEPARTMENT OF REGULATORY AND ECONOMIC RESOURCES (RER)  
BOARD AND CODE ADMINISTRATION DIVISION

MIAMI-DADE COUNTY  
PRODUCT CONTROL SECTION

11805 SW 26 Street, Room 208  
Miami, Florida 33175-2474  
T (786) 315-2590 F (786) 315-2599

[www.miamidade.gov/economy](http://www.miamidade.gov/economy)

**NOTICE OF ACCEPTANCE (NOA)**

Owens Corning  
1 Owens Corning Parkway  
Toledo, OH 43659

**SCOPE:**

This NOA is being issued under the applicable rules and regulations governing the use of construction materials. The documentation submitted has been reviewed and accepted by Miami-Dade County RER - Product Control Section to be used in Miami Dade County and other areas where allowed by the Authority Having Jurisdiction (AHJ).

This NOA shall not be valid after the expiration date stated below. The Miami-Dade County Product Control Section (In Miami Dade County) and/or the AHJ (in areas other than Miami Dade County) reserve the right to have this product or material tested for quality assurance purposes. If this product or material fails to perform in the accepted manner, the manufacturer will incur the expense of such testing and the AHJ may immediately revoke, modify, or suspend the use of such product or material within their jurisdiction. RER reserves the right to revoke this acceptance, if it is determined by Miami-Dade County Product Control Section that this product or material fails to meet the requirements of the applicable building code.

This product is approved as described herein, and has been designed to comply with the Florida Building Code including the High Velocity Hurricane Zone of the Florida Building Code.

**DESCRIPTION: VentSure® Ridge Vent and VentSure® Rigid Roll Ridge Vent**

**LABELING:** Each unit shall bear a permanent label with the manufacturer's name or logo, city, state and following statement: "Miami-Dade County Product Control Approved", unless otherwise noted herein.

**RENEWAL** of this NOA shall be considered after a renewal application has been filed and there has been no change in the applicable building code negatively affecting the performance of this product.

**TERMINATION** of this NOA will occur after the expiration date or if there has been a revision or change in the materials, use, and/or manufacture of the product or process. Misuse of this NOA as an endorsement of any product, for sales, advertising or any other purposes shall automatically terminate this NOA. Failure to comply with any section of this NOA shall be cause for termination and removal of NOA.

**ADVERTISEMENT:** The NOA number preceded by the words Miami-Dade County, Florida, and followed by the expiration date may be displayed in advertising literature. If any portion of the NOA is displayed, then it shall be done in its entirety.

**INSPECTION:** A copy of this entire NOA shall be provided to the user by the manufacturer or its distributors and shall be available for inspection at the job site at the request of the Building Official.

This NOA renews NOA# 13-1010.04 and consists of pages 1 through 5.  
The submitted documentation was reviewed by Alex Tigera.



NOA No.: 17-1107.04  
Expiration Date: 10/31/22  
Approval Date: 12/21/17  
Page 1 of 5

## ROOFING COMPONENT APPROVAL

**Category:** Roofing  
**Sub-Category:** Ventilation  
**Material:** Plastic  
**Minimum Slope:** 3:12

### TRADE NAMES OF PRODUCTS MANUFACTURED OR LABELED BY APPLICANT

<u>Product</u>	<u>Dimensions</u>	<u>Test Specification</u>	<u>Product Description</u>
VentSure® Ridge Vent	11-1/4" wide, 5/8" high, lengths of 4' & 8'	TAS 100(A)	Ridge ventilation system for asphalt shingle roofing systems.
VentSure® Rigid Roll Ridge Vent	11-1/4" wide, 5/8" high, lengths of 20' & 50'	TAS 100(A)	Ridge ventilation system for asphalt shingle roofing systems.

### TRADE NAMES OF PRODUCTS MANUFACTURED BY OTHERS:

<u>Product</u>	<u>Dimensions</u>	<u>Test Specification</u>	<u>Product Description</u>	<u>Manufacturer</u>
Asphalt Roof Cement		ASTM D 4586	Asbestos-free, asphalt based roof cement	Generic
Asphalt Primer		ASTM D 41	Asphalt Primer	Generic
Roofing Nails	2 1/2" long	TAS 114	Corrosion resistant annular ring shank nails	Generic
Roofing Sealant		TAS 132	Polyurethane adhesive sealant	Generic

### MANUFACTURING LOCATION

1. ML #1

### EVIDENCE SUBMITTED

<u>Test Agency/Identifier</u>	<u>Name</u>	<u>Report</u>	<u>Date</u>
Architectural Testing Inc.	ASTM D 635	C1774.01-109-18	09/06/13
	ASTM D 1929	C1774.01-109-18	09/06/13
	ASTM D 2843	C1774.01-109-18	09/06/13
	TAS 100(A)	01-38660.04	04/25/01
	TAS 100(A)	01-38660.05	04/25/01
	TAS 100(A)	C1774.01-109-18	09/06/13
Underwriters Laboratories, Inc.	UL 790	R21038	12/08/03



NOA No.: 17-1107.04  
Expiration Date: 10/31/22  
Approval Date: 12/21/17  
Page 2 of 5

## APPROVED APPLICATIONS

**Tradename:** VentSure® Ridge Vent and VentSure® Rigid Roll Ridge Vent

**System Type:** Mechanical attachment of ridge vent system over composition shingles.

### Cutout:

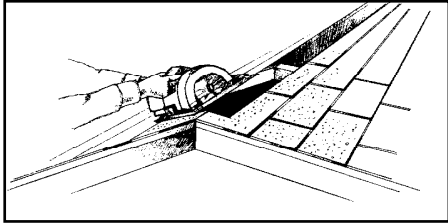

1. Determine whether the rafters are truss or ridgepole construction. Cut sheathing 2" (truss) or 3-1/2" (ridge pole) wide slot (1" truss or 1-3/4" ridge pole on each side) of the ridge(s). A minimum of 6" must be left uncut on each end of the ridge. Once the slot is cut and any overlapping shingles covering the ridge are trimmed and removed, the ridge is ready for vent installation.

### Installation:

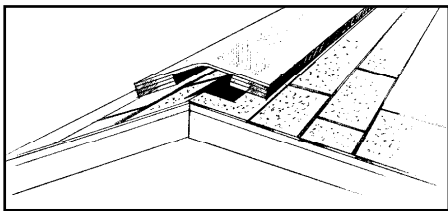

2. Place the VentSure® Ridge Vent or VentSure® Rigid Roll Ridge Vent, routed side down along entire length of slot also covering the 6" minimum uncut ridge on both ends. Multiple lengths of vent can be joined by butting them together.
3. Pull apart a 3" or 5-1/4" precut section of the foam endcap. Using an approved construction adhesive or sealant caulk, coat both sides of the foam material where it has been cut back at the end of the vent. Insert the foam end cap with the cut back foam material between the foam end cap and the underside of the vent to assure a weather-tight seal. Approved sealant must be applied to roof shingles before installing vent.
4. Using four (4) 2 1/2" long corrosion resistant ring shank roofing nails, attach vent to the roof deck by driving a nail in each of the two corners on both ends of the vent, and a nail at each side through the foam cap. Use 2 1/2" long corrosion resistant ring shank roofing nails at 24" on center across the downslope of the ridge to attach vent. Apply an approved polyurethane adhesive sealant at the down-slope leading edges of the ridge vent, at the junction of the leading edge and asphalt shingles.

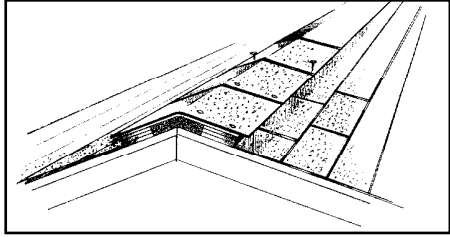

5. After vent has been installed, cut ridge shingles, preform, and install the cap shingles directly to the vent, in compliance with the shingle manufacturer's Notice of Acceptance (NOA) and installation instructions. Lap shingles with a 5" exposure over the ridge vent in a common overlapping pattern and attach using 2 1/2" long corrosion resistant ring shank roofing nails through the ridge vent into the wood deck.

**Net Free Area:** Refer to manufacturer's published literature.

### **LIMITATIONS:**

1. Refer to applicable Building Code for required ventilation.
2. VentSure® Ridge Vent and VentSure® Rigid Roll Ridge Vent shall comply with the manufacturer's current published application instructions and the requirements set forth in the applicable Building Code.
3. VentSure® Ridge Vent and VentSure® Rigid Roll Ridge Vent shall not be installed on roof mean heights greater than 33 feet.
4. All products listed herein shall have a quality assurance audit in accordance with the Florida Building Code and Rule 61G20-3 of the Florida Administrative Code.
5. All approved products listed herein shall be labeled and shall bear the imprint or identifiable marking of the manufacturer's name or logo and following statement: "Miami-Dade County Product Control Approved" or the Miami-Dade County Product Control Seal as shown below:



**NOA No.:** 17-1107.04  
**Expiration Date:** 10/31/22  
**Approval Date:** 12/21/17  
**Page 4 of 5**

**DETAIL DRAWINGS**

**VENTSURE® RIDGE VENT  
AND  
VENTSURE® RIGID ROLL RIDGE VENT**

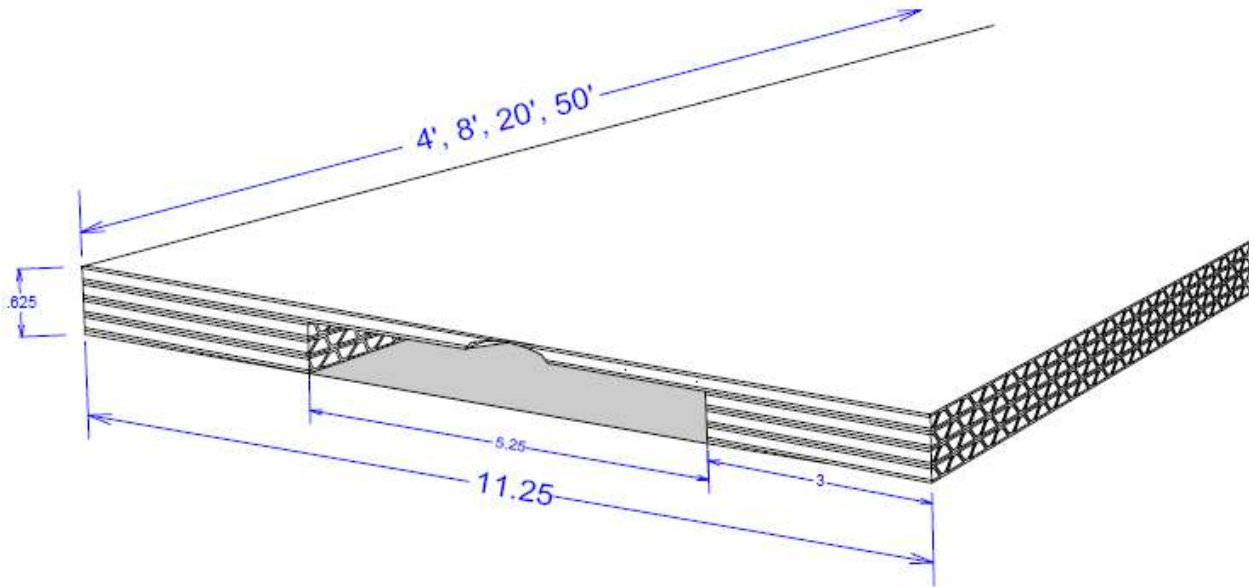

**END OF THIS ACCEPTANCE**



**NOA No.: 17-1107.04  
Expiration Date: 10/31/22  
Approval Date: 12/21/17  
Page 5 of 5**