



DEPARTMENT OF REGULATORY AND ECONOMIC RESOURCES (RER)
BOARD AND CODE ADMINISTRATION DIVISION

MIAMI-DADE COUNTY
PRODUCT CONTROL SECTION
11805 SW 26 Street, Room 208
Miami, Florida 33175-2474
T (786) 315-2590 F (786) 315-2599
www.miamidade.gov/economy

NOTICE OF ACCEPTANCE (NOA)

EKRF, LLC.
8004 NW 154 St. Suite 236
Miami Lakes, FL. 33016

SCOPE:

This NOA is being issued under the applicable rules and regulations governing the use of construction materials. The documentation submitted has been reviewed and accepted by Miami-Dade County RER - Product Control Section to be used in Miami Dade County and other areas where allowed by the Authority Having Jurisdiction (AHJ).

This NOA shall not be valid after the expiration date stated below. The Miami-Dade County Product Control Section (In Miami Dade County) and/or the AHJ (in areas other than Miami Dade County) reserve the right to have this product or material tested for quality assurance purposes. If this product or material fails to perform in the accepted manner, the manufacturer will incur the expense of such testing and the AHJ may immediately revoke, modify, or suspend the use of such product or material within their jurisdiction. RER reserves the right to revoke this acceptance, if it is determined by Miami-Dade County Product Control Section that this product or material fails to meet the requirements of the applicable building code.

This product is approved as described herein, and has been designed to comply with the Florida Building Code including the High Velocity Hurricane Zone of the Florida Building Code.

DESCRIPTION: EKOROOF LITETILE

LABELING: Each unit shall bear a permanent label with the manufacturer's name or logo, city, state and following statement: "Miami-Dade County Product Control Approved", unless otherwise noted herein.

RENEWAL of this NOA shall be considered after a renewal application has been filed and there has been no change in the applicable building code negatively affecting the performance of this product.

TERMINATION of this NOA will occur after the expiration date or if there has been a revision or change in the materials, use, and/or manufacture of the product or process. Misuse of this NOA as an endorsement of any product, for sales, advertising or any other purposes shall automatically terminate this NOA. Failure to comply with any section of this NOA shall be cause for termination and removal of NOA.

ADVERTISEMENT: The NOA number preceded by the words Miami-Dade County, Florida, and followed by the expiration date may be displayed in advertising literature. If any portion of the NOA is displayed, then it shall be done in its entirety.

INSPECTION: A copy of this entire NOA shall be provided to the user by the manufacturer or its distributors and shall be available for inspection at the job site at the request of the Building Official.

This NOA renews NOA 12-0824.03 consists of pages 1 through 11.

The submitted documentation was reviewed by *Freddy Semino* 



NOA No.: 18-0629.01
Expiration Date: 07/04/24
Approval Date: 08/02/18
Page 1 of 11

ROOFING ASSEMBLY APPROVAL

Category: Roofing
Sub-Category: Non-Structural Panel
Materials: Composite
Deck Type: Wood
Maximum Design Pressure -131 psf.
Fire Classification Pressure See General Limitation #1

TRADE NAMES OF PRODUCTS MANUFACTURED OR LABELED BY APPLICANT:

<u>Product</u>	<u>Dimensions</u>	<u>Test Specifications</u>	<u>Product Description</u>
Ekorooft LiteTile	Length: 20" Width: 40" Thickness: 1/4"	TAS 125	Composite roofing panel designed to resemble four S-tiles, for use in mechanically attached systems.

MANUFACTURING LOCATION:

1. Vista de la Sabana, Costa Rica

EVIDENCE SUBMITTED:

<u>Test Agency</u>	<u>Test Identifier</u>	<u>Test Name/Report</u>	<u>Date</u>
Farabaugh Engineering and Testing Inc.	T250-10	TAS 125	06/20/13
	T266-10	TAS-100	11/30/10
Fenestration Testing Laboratory	13-4555	ASTM E 108	05/20/13
PRI Construction Materials Technologies	EKOR-002-02-01	ASTM D 638	05/17/13
	EKOR-001-02-01	ASTM G 26 / G 155	05/23/08
ETC Laboratories	ETC-06-718-17422.0	ASTM D 2843	03/28/06
		ASTM D 635	03/28/06
		ASTM D 1929	03/28/06



APPROVED ASSEMBLIES:

System:	Ekorooft LiteTile
Deck Type:	Wood, Non-Insulated
Deck Description:	Min. $19/32$ " or greater plywood or wood plank. (New Construction). Min. $15/32$ " or greater plywood or wood plank. (Re-Roof only).
Slope Range:	2": 12" or greater
Maximum Uplift Pressure:	See Below

Deck Attachment: In accordance with applicable building code, but in no case shall it be less than #8 x 2" long wood screws spaced 6" o.c. In reroofing, where the deck is less than $19/32$ " thick, but no less than $15/32$ " thick, the above attachment method must be in addition to existing attachment.

Underlayment: Minimum underlayment shall be an ASTM D 226 Type II installed with a minimum 4" side-lap and 6" end-laps. Underlayment shall be fastened with corrosion resistant tin-caps and 12 gauge 1 1/4" annular ring-shank nails, spaced 6" o.c. at all laps and two staggered rows 12" o.c. in the field of the roll. Or, any approved underlayment having a current NOA.

Fire Barrier: Any approved fire barrier having a current NOA. Refer to a current fire directory listing for fire ratings of this roofing system assembly as well as the location of the fire barrier within the assembly. See Limitation # 1.

Valleys: Valley construction shall be in compliance with Roofing Application Standard RAS 133 and with EKRF, LLC's current published installation instructions.

**Panel Installation:
(Field Condition)** Install the "Ekorooft LiteTile" and accessories in compliance with the current published installation instructions and details in EKRF LLC's Installation Manual. Flashings, penetrations, valley construction and other details shall be constructed in compliance with Roofing Application Standard RAS 133.

Begin the installation of the panels by positioning a 2-1/2" long x 2-1/2" wide x 1/2" high wood block under each pre-manufactured dimple in the front/flat section of the panels. The starter row is to be fastened to the deck using **one** #10-12 x 2" long stainless steel through the marked dimple, penetrating the wood block and wood deck. Avoid penetrating metal valleys when fastening. Fasteners may be slightly offset to avoid valleys or plywood joints as needed. There will be a total of 4 fasteners along the bottom. See **Detail C and D**.

Secure the top of the panel using one #10-12 x 2" long stainless steel through each pre-manufactured screw button penetrating the panel and deck. There will be a total of 4 fasteners along the top of the panel. See **Detail C and D**.

Align adjacent panel and secure as described above. Additionally use a #10-13 x 1" long stainless steel concealer screw approximately 1" away from each edge at the bottom of the panels to secure each panel together. See **Detail D**.

The second row of panels shall be installed by aligning the nose of the panels with the Tile Alignment Brow on the panel of the 1st row. Once the panel is in place, secure the bottom of the panel with **one** #10-12 x 2” long stainless steel through the marked dimple, penetrating the screw block and wood deck. There will be a total of 4 fasteners along the bottom. See **Detail C and D**.

Secure the top of the panel using one #10-12 x 2” long stainless steel through each pre-manufactured screw button penetrating the panel and deck. There will be a total of 4 fasteners along the top of the panel. See **Detail C and D**.

**Maximum Design Pressure:
(Field Condition)**

-86 psf. (See General Limitation #2)

**Panel Installation:
(Perimeter and Corner Condition)**

Begin the installation of the panels by positioning a 2-1/2” long x 2-1/2” wide x 1/2” high wood block under each pre-manufactured dimple in the front/flat section of the panels. The starter row is to be fastened to the deck using **two** #10-12 x 2” long stainless steel through the marked dimple, penetrating the wood block and wood deck. Avoid penetrating metal valleys when fastening. Fasteners may be slightly offset to avoid valleys or plywood joints as needed. There will be a total of 8 fasteners along the bottom. See **Detail C and E**.

Secure the top of the panel using one #10-12 x 2” long stainless steel through each pre-manufactured screw button penetrating the panel and deck. There will be a total of 4 fasteners along the top of the panel. See **Detail C and E**.

Align adjacent panel and secure as described above. Additionally use a #10-13 x 1” long stainless steel concealer screw approximately 1” away from each edge at the bottom of the panels to secure each panel together. See **Detail E**.

The second row of panels shall be installed by aligning the nose of the panels with the Tile Alignment Brow on the panel of the 1st row. Once the panel is in place, secure the bottom of the panel with **two** #10-12 x 2” long stainless steel through the marked dimple, penetrating the screw block and wood deck. There will be a total of 8 fasteners along the bottom. See **Detail C and E**.

Secure the top of the panel using one #10-12 x 2” long stainless steel through each pre-manufactured screw button penetrating the panel and deck. There will be a total of 4 fasteners along the top of the panel. See **Detail C and E**.

**Maximum Design Pressure:
(Perimeter and Corner Condition)**

-131 psf. (See General Limitation #2)



GENERAL LIMITATIONS:

1. Fire classification is not part of this acceptance; refer to a current Approved Roofing Materials Directory for fire ratings of this product.
2. The maximum designed pressure limitation listed shall be applicable to all roof pressure zones (i.e. field, perimeters, and corners). Neither rational analysis, nor extrapolation shall be permitted for enhanced fastening at enhanced pressure zones (i.e. perimeters, extended corners and corners).
3. All panels shall be permanently labeled with the manufacturer's name and/or logo, and the following statement: "Miami-Dade County Product Control Approved" **or** with the Miami-Dade County Product Control Seal as seen below.



4. All products listed herein shall have a quality assurance audit in accordance with the Florida Building Code and Rule 61G20-3 of the Florida Administrative Code.



PROFILE DRAWINGS

DETAIL A

EKOROOF LITETILE DIMENSIONS

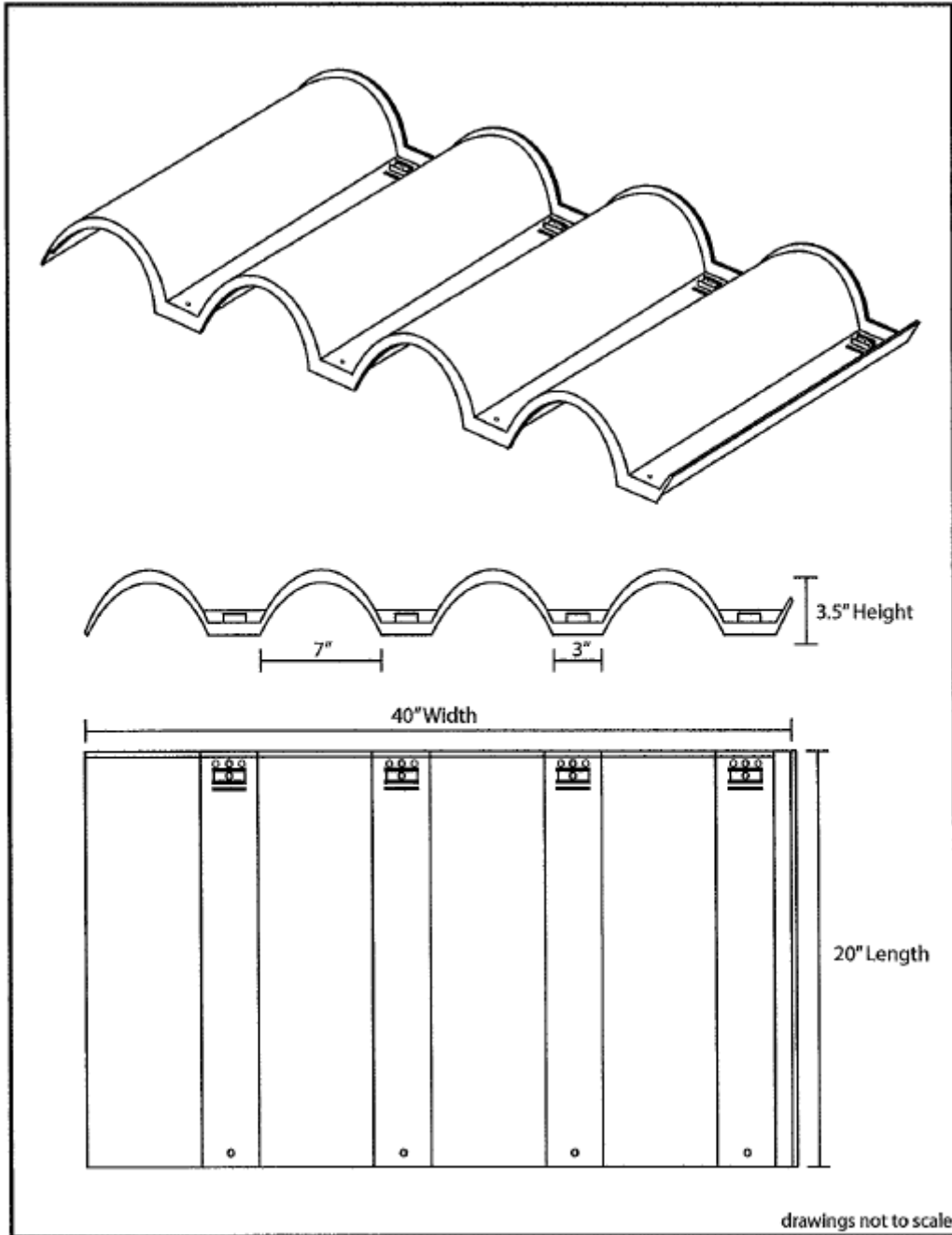

© Copyright EKRF, LLC



NOA No.: 18-0629.01
Expiration Date: 07/04/24
Approval Date: 08/02/18
Page 6 of 11

DETAIL B

EKOROOF LITETILE TOP DETAIL

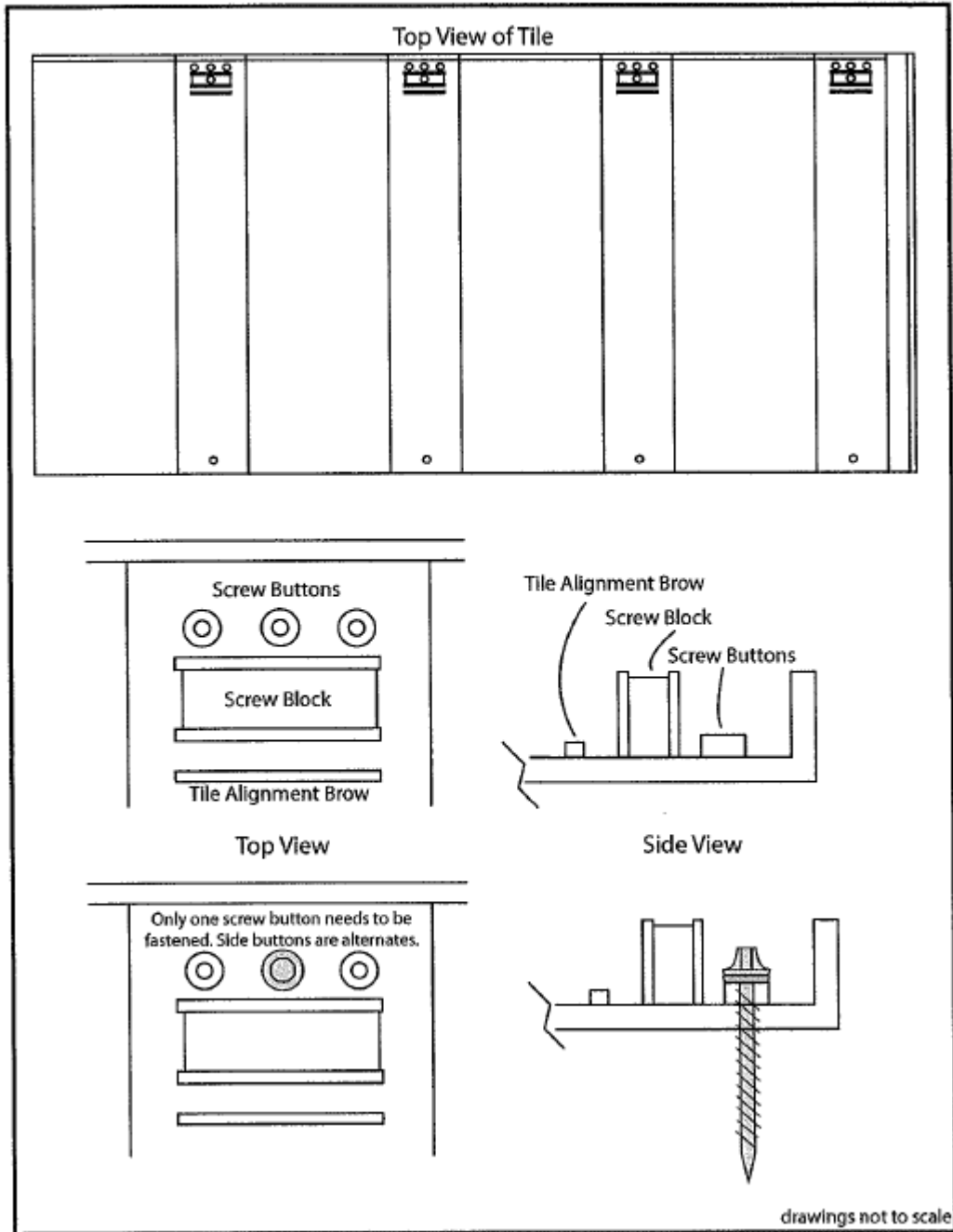

© Copyright EKRF, LLC



NOA No.: 18-0629.01
Expiration Date: 07/04/24
Approval Date: 08/02/18
Page 7 of 11

DETAIL C

EKOROOF LITETILE – INSTALLATION DETAIL

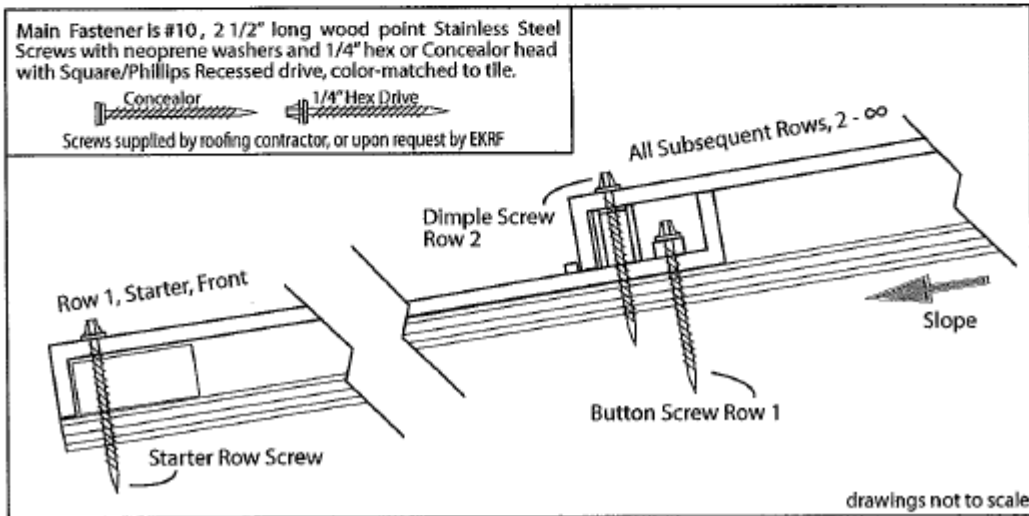
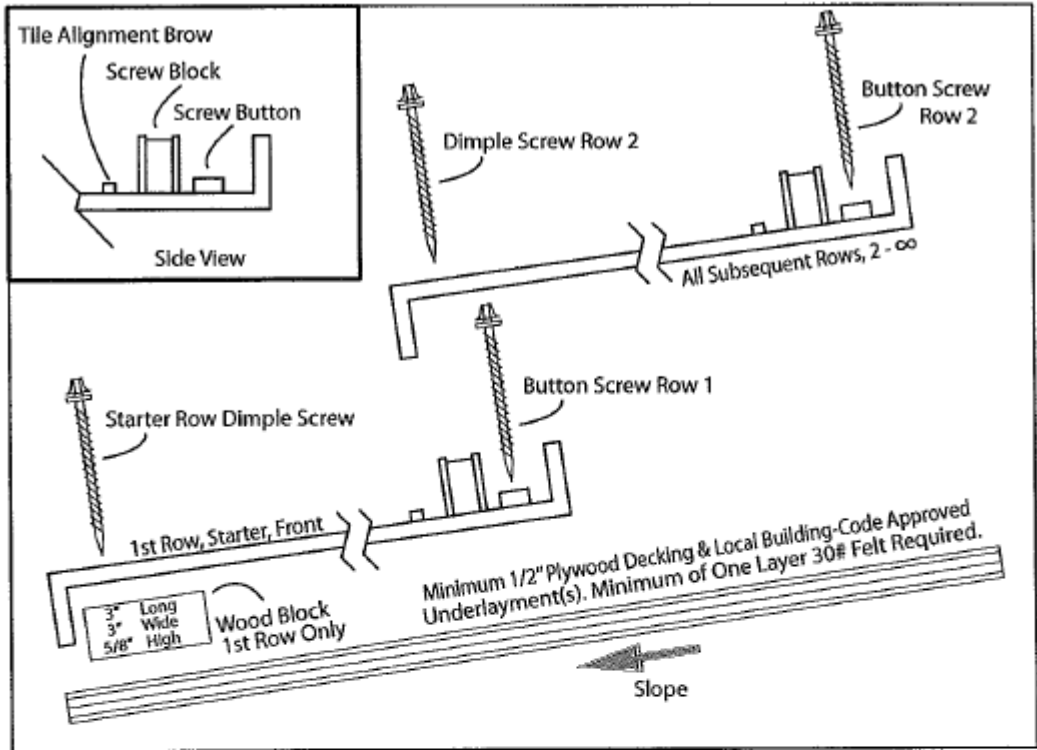

© Copyright EKRF, LLC



NOA No.: 18-0629.01
Expiration Date: 07/04/24
Approval Date: 08/02/18
Page 8 of 11

DETAIL D

EKOROOF LITE TILE – INSTALLATION DETAIL FIELD CONDITIONS

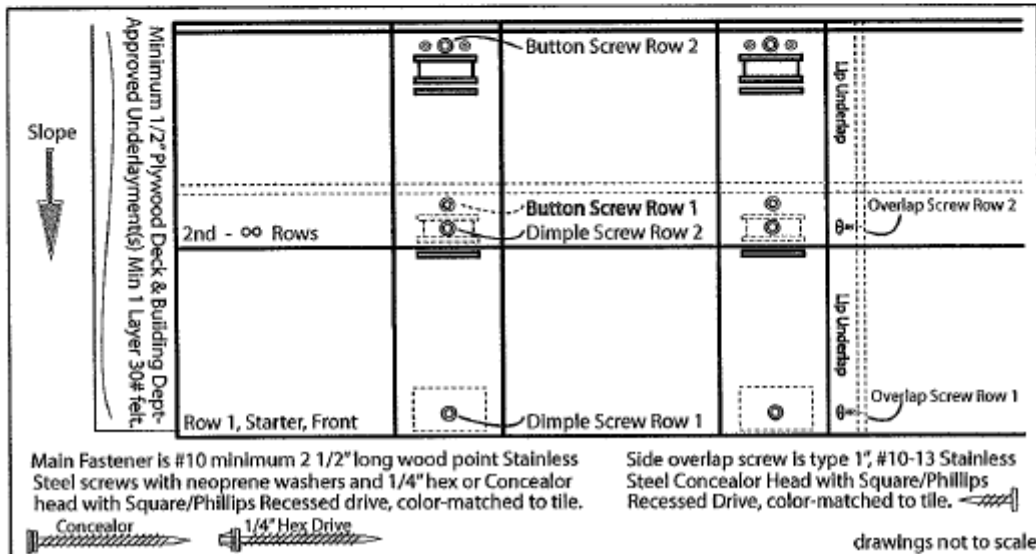
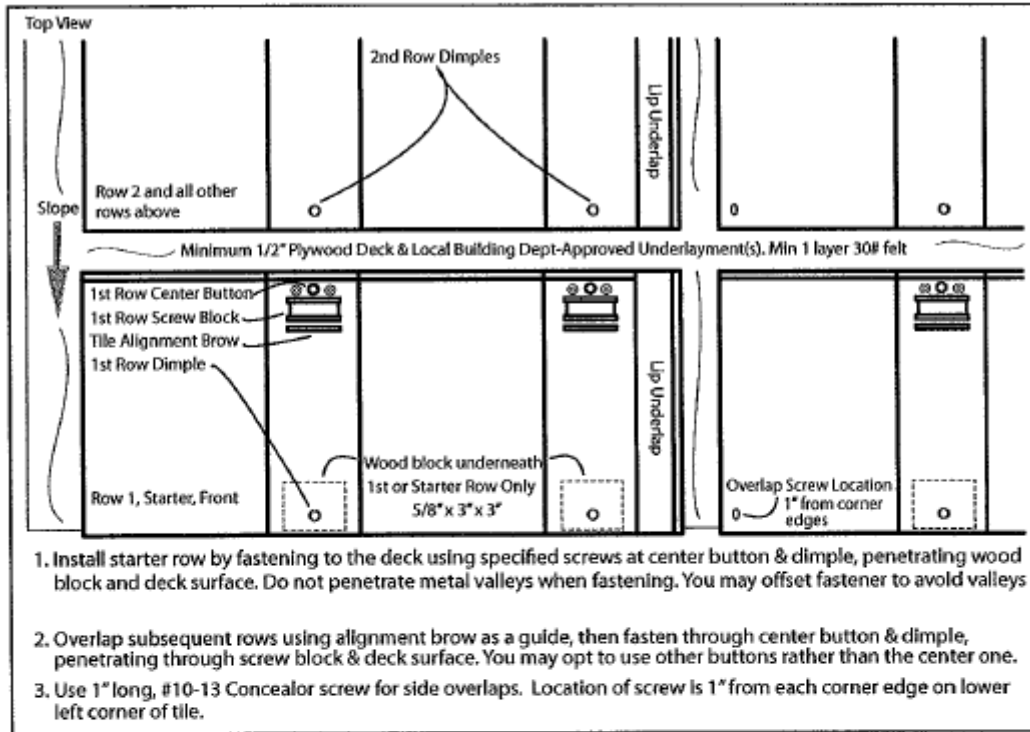

© Copyright EKRF, LLC



DETAIL E

EKOROOF LITE TILE – INSTALLATION DETAIL – PERIMETER AND CORNER CONDITION

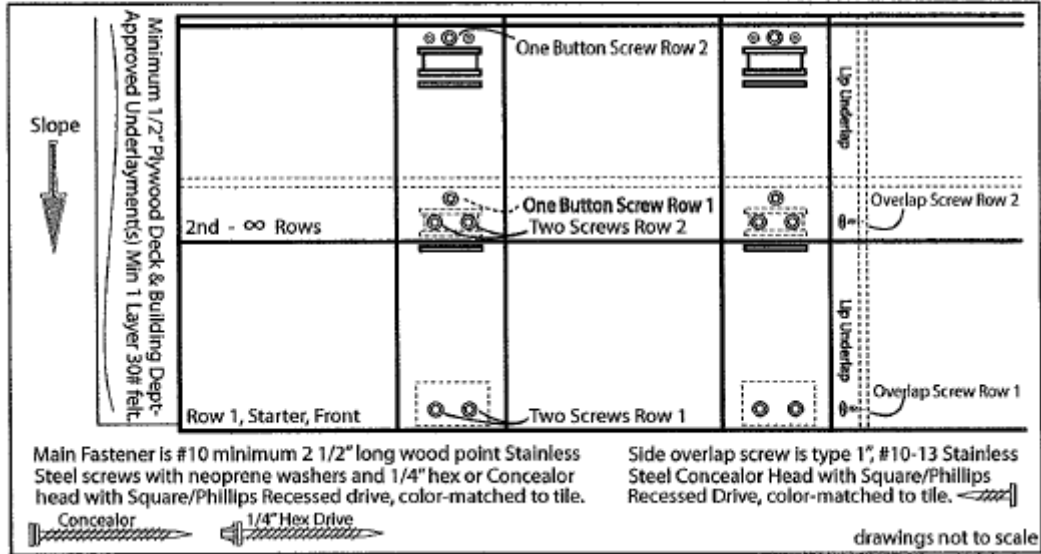

© Copyright EKRF, LLC



DETAIL F

EKOROOF LITETILE – INSTALLATION DETAIL – RIDGE AND RAKE

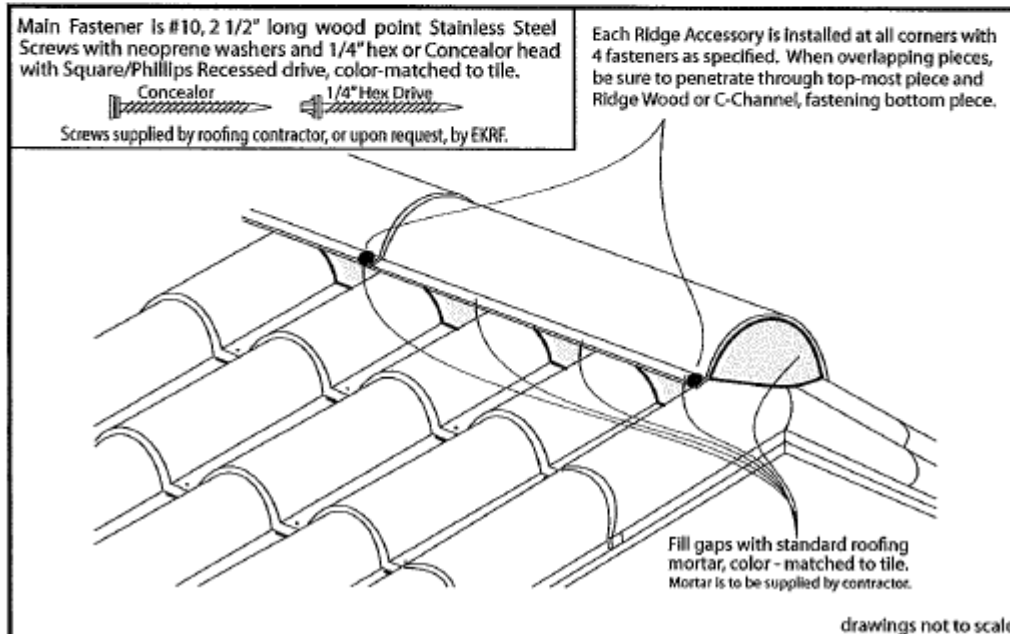
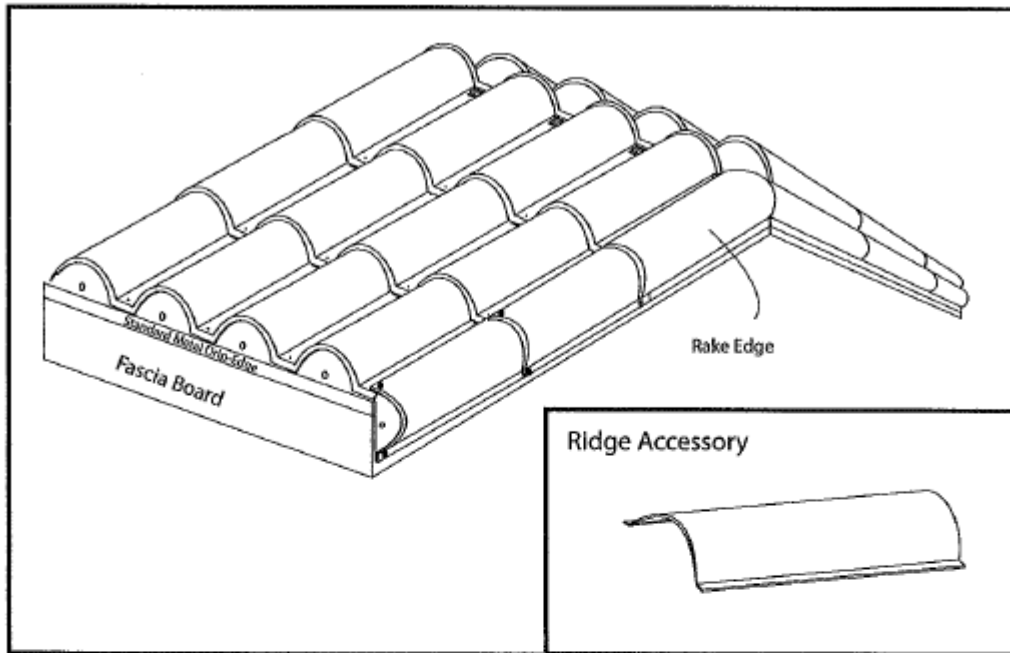

© Copyright EKRF, LLC

END OF THIS ACCEPTANCE



NOA No.: 18-0629.01
 Expiration Date: 07/04/24
 Approval Date: 08/02/18
 Page 11 of 11