



MIAMI-DADE COUNTY  
 PRODUCT CONTROL SECTION  
 11805 SW 26 Street, Room 208  
 Miami, Florida 33175-2474  
 T (786) 315-2590 F (786) 315-2599  
[www.miamidade.gov/economy](http://www.miamidade.gov/economy)

DEPARTMENT OF REGULATORY AND ECONOMIC RESOURCES (RER)  
 BOARD AND CODE ADMINISTRATION DIVISION  
**NOTICE OF ACCEPTANCE (NOA)**

**The Limited Edition Glassworks Inc.**  
**51 Delta Park Blvd.**  
**Brampton, Ontario, Canada L6T5E7**

**SCOPE:**

This NOA is being issued under the applicable rules and regulations governing the use of construction materials. The documentation submitted has been reviewed and accepted by Miami-Dade County RER - Product Control Section to be used in Miami Dade County and other areas where allowed by the Authority Having Jurisdiction (AHJ).

This NOA shall not be valid after the expiration date stated below. The Miami-Dade County Product Control Section (In Miami Dade County) and/or the AHJ (in areas other than Miami Dade County) reserve the right to have this product or material tested for quality assurance purposes. If this product or material fails to perform in the accepted manner, the manufacturer will incur the expense of such testing and the AHJ may immediately revoke, modify, or suspend the use of such product or material within their jurisdiction. RER reserves the right to revoke this acceptance, if it is determined by Miami-Dade County Product Control Section that this product or material fails to meet the requirements of the applicable building code. This product is approved as described herein, and has been designed to comply with the Florida Building Code, including the High Velocity Hurricane Zone.

**DESCRIPTION: Series "PVC Lite-kit Assembly"-Component approval**

**APPROVAL DOCUMENT:** Drawing No. **LED-LK3080 Rev #4**, titled "Impact-Resistant PVC Lite Kit Assembly" sheets 1 through 2 of 2, dated 05/02/06 and last revised on 12/19/18, prepared by Category 5 Engineering Services, signed and sealed by Emma T. Mellinger, P.E., bearing the Miami-Dade County Product Control Revision stamp with the Notice of Acceptance number and expiration date by the Miami-Dade County Product Control Section.

**MISSILE IMPACT RATING: Large and Small Missile Impact Resistant**

**Limitation:**

- 1. This kit is to be used w/ approved Impact single glazed door system, having current NOA.**

**LABELING:** Each unit shall bear a permanent label with the manufacturer's name or logo, Ontario, Canada and series and following statement: "Miami-Dade County Product Control Approved", unless otherwise noted herein.

**RENEWAL** of this NOA shall be considered after a renewal application has been filed and there has been no change in the applicable building code negatively affecting the performance of this product.

**TERMINATION** of this NOA will occur after the expiration date or if there has been a revision or change in the materials, use, and/or manufacture of the product or process. Misuse of this NOA as an endorsement of any product, for sales, advertising or any other purposes shall automatically terminate this NOA. Failure to comply with any section of this NOA shall be cause for termination and removal of NOA.

**ADVERTISEMENT:** The NOA number preceded by the words Miami-Dade County, Florida, and followed by the expiration date may be displayed in advertising literature. If any portion of the NOA is displayed, then it shall be done in its entirety.

**INSPECTION:** A copy of this entire NOA shall be provided to the user by the manufacturer or its distributors and shall be available for inspection at the job site at the request of the Building Official. This NOA revises NOA #16-0920.07 and consists of this page 1 and evidence pages E-1 and E-2, as well as approval document mentioned above.

The submitted documentation was reviewed by **Ishaq I. Chanda, P.E.**



NOA No. 19-0110.08  
 Expiration Date: September 21, 2021  
 Approval Date: February 07, 2019  
 Page 1

2/7/19

**NOTICE OF ACCEPTANCE: EVIDENCE SUBMITTED**

**1. Evidence submitted under previous approvals**

**A. DRAWINGS**

1. Manufacturer's parts drawings and sections (submitted under files referenced below).
2. Drawing No. **LED-LK3080 Rev #3**, titled "Impact-Resistant PVC Lite Kit Assembly" sheets 1 through 2 of 2, dated 05/02/06 and last revised on 11/09/16, prepared by Category 5 Engineering Services, signed and sealed by Emma T. Mellinger, P.E.

**B. TESTS (Submitted under files #11-0621.06/# 05-1130.01)**

1. Test reports on:
  - 1) Air Infiltration Test, per FBC, TAS 202-94
  - 2) Uniform Static Air Pressure Test, Loading per FBC TAS 202-94
  - 3) Water Resistance Test, per FBC, TAS 202-94
  - 4) Large Missile Impact Test per FBC, TAS 201-94
  - 5) Cyclic Wind Pressure Loading per FBC, TAS 203-94
  - 6) Forced Entry Test, per FBC 2411 3.2.1, TAS 202-94

Along with marked-up drawings and installation diagram of PVC lite-kit in single fixed PVC frame, prepared by Intertek, Test Report No. **102473091COQ-001A**, dated July 27, 2016, signed and sealed by Rick Curkeet, P.E.

Along with marked-up drawings and installation diagram of PVC lite-kit in single operable & fixed door, prepared by Intertek ETL SEMKO, Test Report No. **3081855**, dated October 11, 2005 with addendum letter dated July 17, 2006, signed and sealed by Stephen Emerman, P.E.

2. Test report No. **3081855** on fasteners "pull out" test per ASTM-D-1761 dated 09-29-05, issued by Intertek ETL SEMKO.

**C. CALCULATIONS**

1. Anchor verification calculation dated 11/09/16, prepared by Category 5 Engineering Services, signed and sealed by Emma T. Mellinger, P.E.
2. Glazing complies w/ ASTM E-1300-02 & -04

**D. QUALITY ASSURANCE**

1. Miami Dade Department of Regulatory and Economic Resources (RER).

**E. MATERIAL CERTIFICATIONS**

1. Notice of Acceptance No #**15-0528.14** issued to Vision Extrusion Ltd., for their "**White Rigid PVC Extrusion**", expiring on 09/30/19.
2. Notice of Acceptance No. **14-0916.10** issued to Kuraray America, Inc. (former E.I. DuPont DE Nemours & Co., Inc.) for "**Kuraray Butacite PVB Interlayer**", expiring on 12/11/16
3. Notice of Acceptance No. **12-1231.10** issued to **Eastman Chemical Company (MA)** (former Solutia, Inc.) for the "**Saflex: Saflex Clear & Color glass interlayer**", expiring on 05/21/16

**F. STATEMENTS**

1. Statement letter of conformance and letter of no financial interest dated 11/09/16, prepared by Category 5 Engineering Services, signed & sealed by Emma T. Mellinger, P.E.
2. Distributor agreement dated OCT 03, 2016 between the The Limited Edition Glassworks Inc., Canada and The Door factory, USA, signed by Gerry Rizzardo and Nicholas Nicosia, respectively on behalf of their company.
3. Statement of lab compliance, as part of above referenced test reports.



Ishaq I. Chanda, P.E.  
Product Control Unit Supervisor  
NOA No. 19-0110.08  
Expiration Date: September 21, 2021  
Approval Date: February 07, 2019

**The Limited Edition Glassworks Inc.**

**NOTICE OF ACCEPTANCE: EVIDENCE SUBMITTED**

**G. OTHER**

1. This NOA **revises & renews** NOA # **11-0621.06**, expiring on Sep. 24, 2021.
2. Test Proposal No. **05-0103**, approved by BCCO on May 13, 2005

**2. New Evidence submitted under previous approvals**

**A. DRAWINGS**

1. Drawing No. **LED-LK3080 Rev #4**, titled "Impact-Resistant PVC Lite Kit Assembly" sheets 1 through 2 of 2, dated 05/02/06 and last revised on 12/19/18, prepared by Category 5 Engineering Services, signed and sealed by Emma T. Mellinger, P.E.

**B. TESTS**

1. None.

**C. CALCULATIONS**

1. Fasteners verification dated DEC 18, 2018 in compliance per FBC 2017 (6<sup>th</sup> Edition), prepared by Category 5 Engineering Services, signed and sealed by Emma T. Mellinger, P.E

**D. QUALITY ASSURANCE**

1. Miami Dade Department of Regulatory and Economic Resources (RER).

**E. MATERIAL CERTIFICATIONS**

1. Notice of Acceptance No #**15-0528.14** issued to Vision Extrusion Ltd., for their "**White Rigid PVC Extrusion**", expiring on 09/30/19.
2. Notice of Acceptance No. **16-117.01** issued to Kuraray America, Inc. (former E.I. DuPont DE Nemours & Co., Inc.) for "**Trofosil Ultra clear PVB Interlayer**", expiring on 07/08/19.
3. Notice of Acceptance No. **17-0712.05** issued to **Eastman Chemical Company (MA)** (former Solutia, Inc.) for the "**Saflex: Saflex Clear & Color glass interlayer**", expiring on 05/21/21.

**F. STATEMENTS**

1. Statement letter of conformance and letter of no financial interest dated 11/09/16, prepared by Category 5 Engineering Services, signed & sealed by Emma T. Mellinger, P.E.
2. Distributor agreement dated OCT 03, 2016 between the The Limited Edition Glassworks Inc., Canada and The Door factory, USA, signed by Gerry Rizzardo and Nicholas Nicosia, respectively on behalf of their company.(submitted under file # **16-0920.07**).

**G. OTHER**

1. This NOA **revises** NOA # **16-0920.07**, expiring on Sep. 21, 2021.



Ishaq I. Chanda, P.E.  
Product Control Unit Supervisor  
NOA No. 19-0110.08  
Expiration Date: September 21, 2021  
Approval Date: February 07, 2019

# THE LIMITED EDITION GLASSWORKS, INC.

51 Delta Park Blvd., Brampton, ON L6T 5E7 Canada  
Tel: (905) 791-8200 Fax: (905) 791-1545

## GENERAL NOTES AND LIMITATIONS

4 This Product Has Been Designed To Comply With the HVHZ Requirements of the Florida Building Code, 6th Edition (2017).

In Windborne Debris Regions, Hurricane Shutters SHALL NOT be Required When This Product is Used In Conjunction With a Miami-Dade County Approved Large Missile Impact Resistant Door Panel Meeting the Specifications Below.

Glazing Options are Shown on Sheet 2

## LIMITATIONS

This Impact-Tested Lite Kit Assembly (as a Component) is to be used as a Substitute to a Similar Assembly in an Impact-Tested Single Glazed Door System of Same or Superior Construction Holding a Current Miami-Dade County Notice of Acceptance.

The Lower Design Pressure of This Product, or the Approved Impact-Tested Door System Shall Control.

This Product SHALL NOT be Used or Approved With an Opaque Door System NOA.

## SPECIFICATIONS FOR ACCEPTABLE DOOR PANELS

Impact-Tested Door System Shall Hold a Current Miami-Dade County NOA, and Meet The Minimum Requirements Listed Below to be Used With This Component Approval.

1. Single-Glazed Fixed, Single-Glazed Outswinging, or Single-Glazed Inswinging (Swinging Doors Require (2) Surface Bolts on Active Panel).
2. Maximum Nom. Panel Size: 36" x 96".
3. Minimum Panel Thickness: 1 3/4".
4. Interior Filled with Rigid Polyurethane Foam Complying With FBC Plastics Requirements.
5. Steel- or Fiberglass-Clad as Follows:

### FIBERGLASS DOOR PANELS

4 Skin: 0.075" Min. Thick Fiberglass (Fy Min = 5,403 psi. after Weathering Test per Section 2615 of FBC, 6th Ed. [2017]).  
Rails: 0.96875" Wood Composite.  
Stiles: 1.625" Laminated Lumber.

### STEEL DOOR PANELS

Skin: Minimum 26 Gauge (0.017") Steel w/Fy Min = 43,270 psi.  
Edges: Wood, Wood-Composite (Min. 3/32" Top & Bottom Rails, or Roll-Formed Steel.

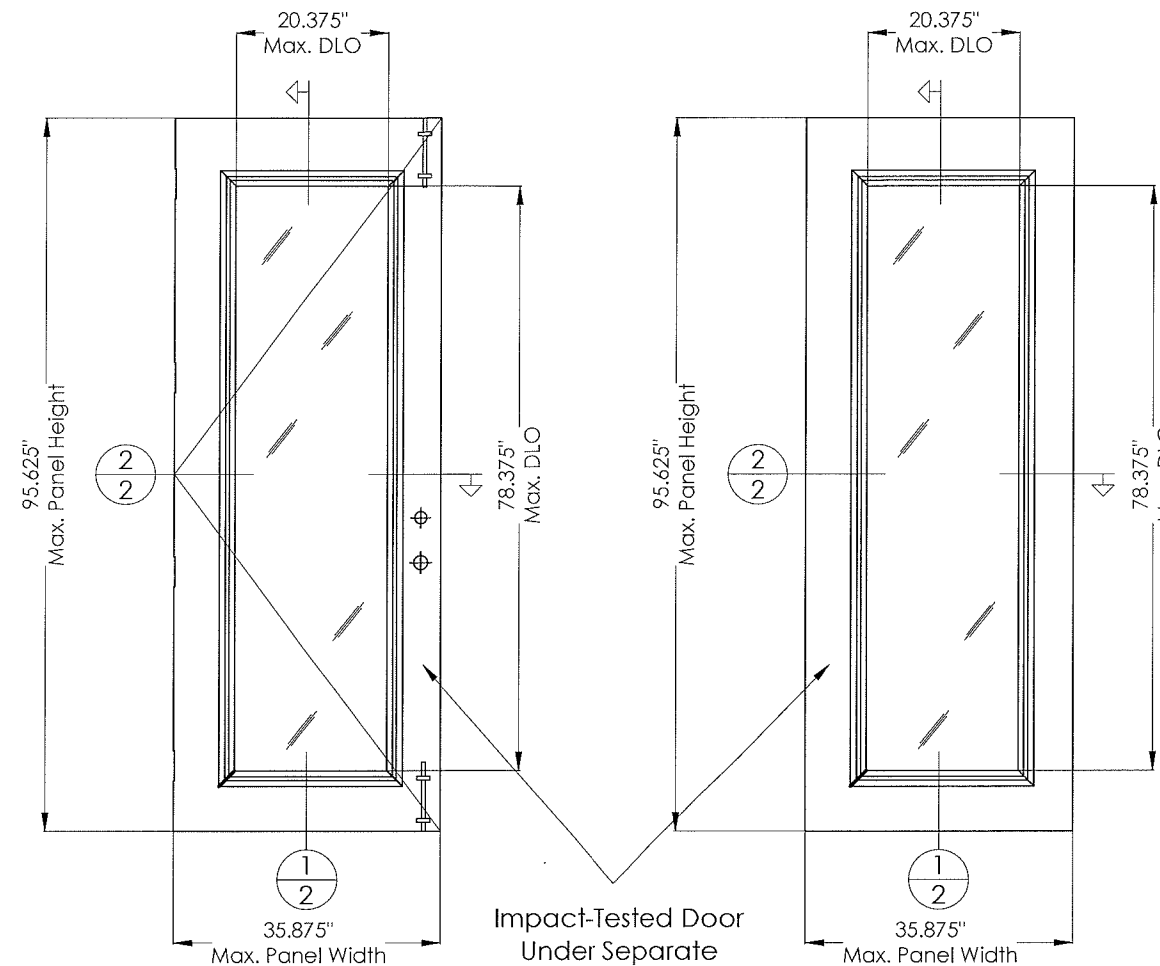

**SINGLE-GLAZED  
SWINGING DOOR PANEL**  
(2) Surface Bolts on Active Panel

**FIXED DOOR PANEL**

**LIMITED EDITION  
GLASSWORKS  
LITE KIT ONLY**

LITE-KIT DESIGN PRESSURE RATING  
(All Configurations Shown)

+60 psf

-60 psf

PRODUCT REVIEWED  
as complying with the Florida  
Building Code  
Acceptance No. 19-0110-08  
Expiration Date SEP 21, 2021  
E. (Shay) L. Lander  
Miami-Dade Product Control

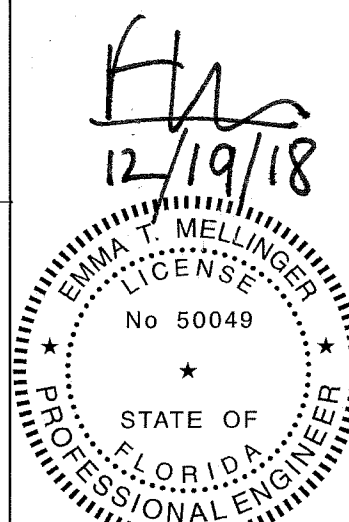

REVISIONS	
No	Date
0	05/02/06
1	08/21/06
2	06/13/11
3	11/04/16
4	12/18/18

IMPACT-RESISTANT PVC LITE-KIT ASSEMBLY  
(Component Approval)  
The Limited Edition Glassworks, Inc.

ELEVATION and SPECIFICATIONS

Sheet 1 of 2

**CATEGORY 5**  
Engineering Services  
1600 S. Federal Highway, #207  
Pompano Beach, FL 33062  
(954) 784-6991 • CA #25854

DRAWING No.:  
LED-LK3080 R4

REVISIONS	
No	By Description
0	05/02/06 EM Original Issue
1	08/21/06 EM Per M-D BCCO
2	06/13/11 EM Ref. 2007 FBC
3	11/04/16 EM Ref. 2014 FBC
4	12/18/18 EM Ref. 2017 FBC

**IMPACT-RESISTANT PVC LITE-KIT ASSEMBLY**  
(Component Approval)  
The Limited Edition Glassworks, Inc.

**SECTION and BILL of MATERIALS**

Sheet **2** of 2

*EM*  
12/19/18

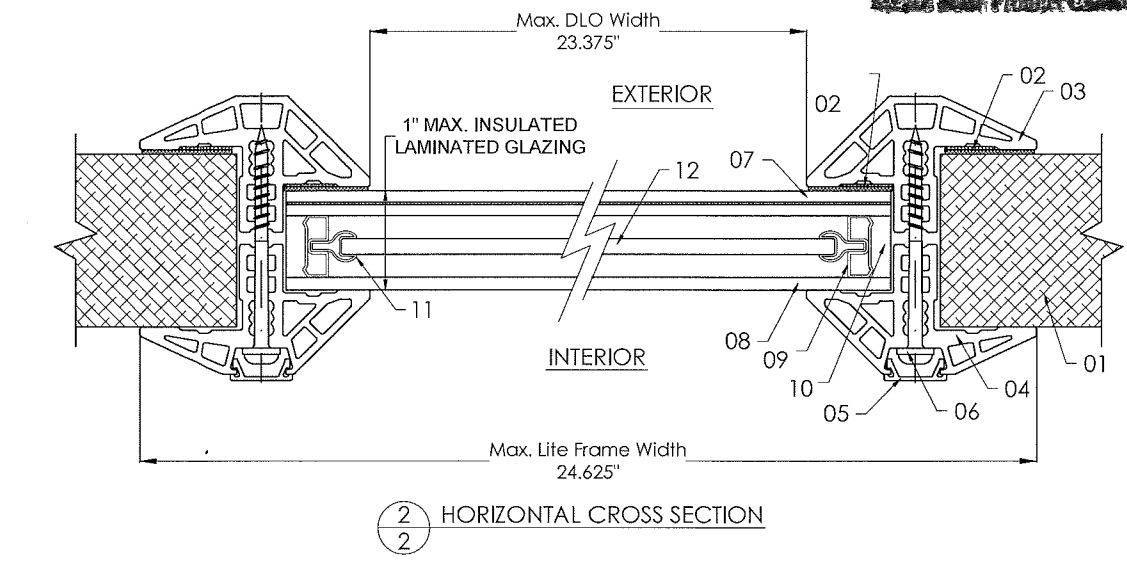
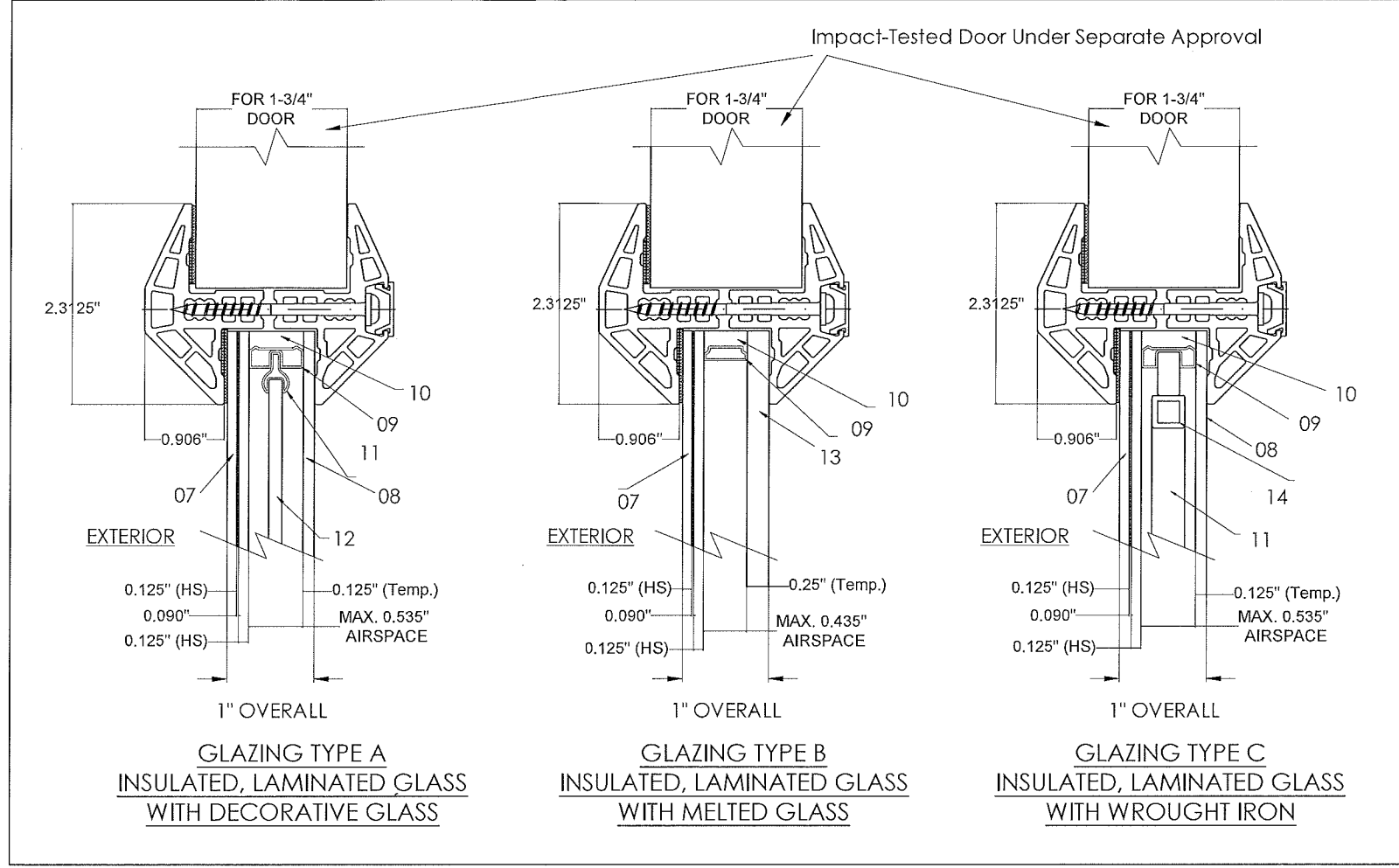
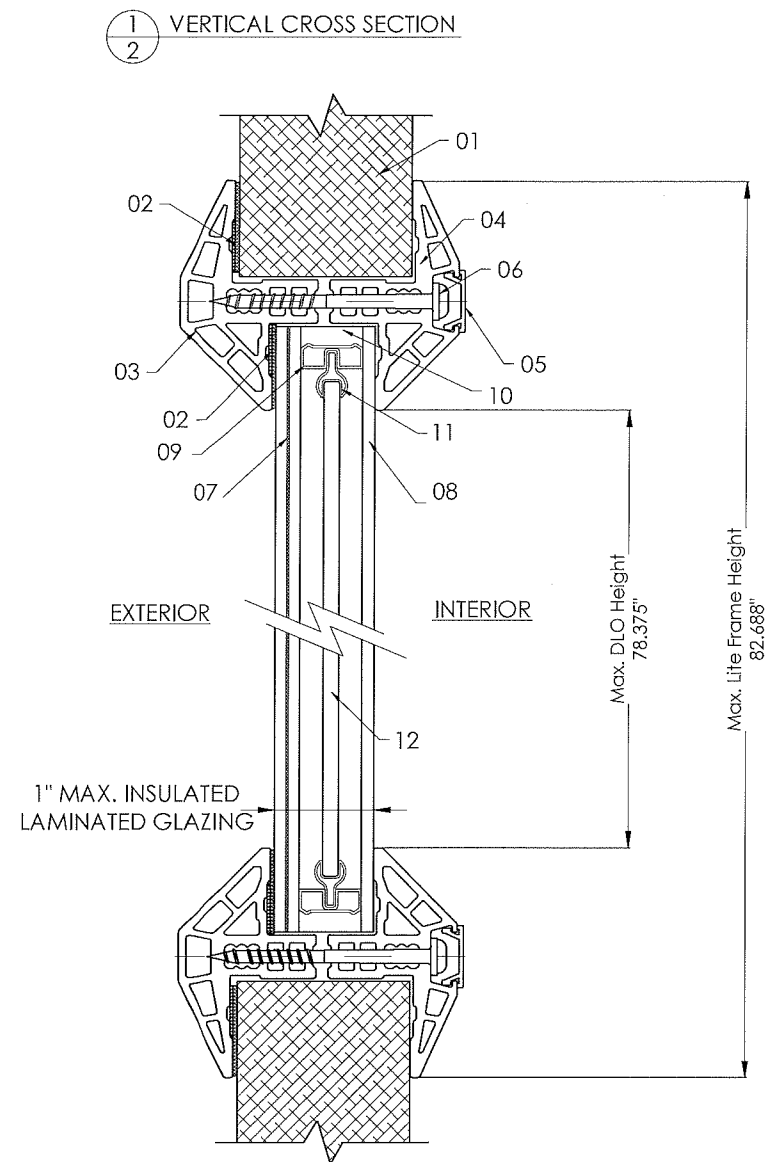
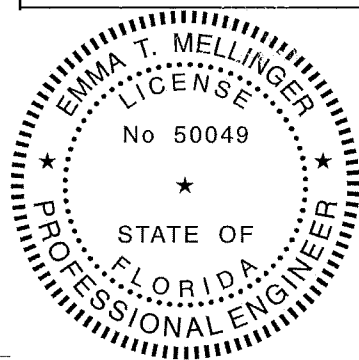

**PRODUCT REVISED**  
as complying with the Florida Building Code  
Acceptance No. 19-0110-08  
Expiration Date 9/21/21  
*Michael Stein Product Control*

**BILL OF MATERIALS**

#	Description	Material	Type	Dimensions	Note
01	Miami-Dade Product Approved Impact-Tested Door <sup>1</sup>			1.75" x 36" x 96"	See Specs on Sheet 1
02	Double Coated Tape	Acrylic	3M VHB 4941	0.09" x .75"	L = 408"
03	External Frame	White PVC <sup>3</sup>		1.375" x 2.125"	Vision Extrusions, Ltd
04	Internal Frame	White PVC <sup>3</sup>		1.3125" x 23125"	Vision Extrusions, Ltd
05	Cover for Internal Frame	White PVC <sup>3</sup>		0.222" x 0.625"	Vision Extrusions, Ltd
06	Deep Threaded Screw	Steel	Flanged Panhead	# 8 x 2.25"	2" From Corners, 7" o/c.
07	Laminated Glass <sup>2</sup> (Part of Overall Insulated Glass)			5/16" x 22" x 80"	Guardian
08	Nom 1/8" Tempered Glass (Part of Overall Insulated Glass)			1/8" x 22" x 80"	Guardian
09	Door Life Spacer	Aluminum	DRL 125		RPM Rollforming
10	Two Component Sealant	Polysulphide	Thiover		Fenzi
11	Y - Caming Profile	Brass / Zinc	BY-916 CAMEN		RPM Rollforming
12	Decorative Glass Panel				Limited Edition
13	1/4" Tempered Melted Glass (Part of Overall Insulated Glass)			1/4" x 22" x 80"	Guardian
14	Wrought Iron Panel				Limited Edition

<sup>1</sup> - Refer to Sheet 1 For Specifications For Acceptable Door Panels

<sup>2</sup> - Insulated Laminated Glass - (2) Lites of Nom. 1/8" HS Glass with 0.090" Interlayer

<sup>3</sup> - Interlayer Shall be Either SAFELEX by Eastman Chemical Co, or KURARAY AMERICA PVB, and Shall Hold a Current Miami-Dade NOA.

<sup>3</sup> - Extrusion to be Labelled with AAMA's PVC Extrusion Certification Label, "MDCA" and Extrusion Number.