



DEPARTMENT OF REGULATORY AND ECONOMIC RESOURCES (RER)
BOARD AND CODE ADMINISTRATION DIVISION

MIAMI-DADE COUNTY
PRODUCT CONTROL SECTION
11805 SW 26 Street, Room 208
Miami, Florida 33175-2474
T (786) 315-2590 F (786) 315-2599
www.miamidade.gov/economy

NOTICE OF ACCEPTANCE (NOA)

Claymex Brick & Tile Inc.
2696 Second St.
Eagle Pass, TX. 78852

SCOPE:

This NOA is being issued under the applicable rules and regulations governing the use of construction materials. The documentation submitted has been reviewed and accepted by Miami-Dade County RER - Product Control Section to be used in Miami Dade County and other areas where allowed by the Authority Having Jurisdiction (AHJ).

This NOA shall not be valid after the expiration date stated below. The Miami-Dade County Product Control Section (In Miami Dade County) and/or the AHJ (in areas other than Miami Dade County) reserve the right to have this product or material tested for quality assurance purposes. If this product or material fails to perform in the accepted manner, the manufacturer will incur the expense of such testing and the AHJ may immediately revoke, modify, or suspend the use of such product or material within their jurisdiction. RER reserves the right to revoke this acceptance, if it is determined by Miami-Dade County Product Control Section that this product or material fails to meet the requirements of the applicable building code.

This product is approved as described herein, and has been designed to comply with the Florida Building Code including the High Velocity Hurricane Zone of the Florida Building Code.

DESCRIPTION: **Spanish Tile**

LABELING: Each unit shall bear a permanent label with the manufacturer's name or logo, city, state and following statement: "Miami-Dade County Product Control Approved", unless otherwise noted herein.

RENEWAL of this NOA shall be considered after a renewal application has been filed and there has been no change in the applicable building code negatively affecting the performance of this product.

TERMINATION of this NOA will occur after the expiration date or if there has been a revision or change in the materials, use, and/or manufacture of the product or process. Misuse of this NOA as an endorsement of any product, for sales, advertising or any other purposes shall automatically terminate this NOA. Failure to comply with any section of this NOA shall be cause for termination and removal of NOA.

ADVERTISEMENT: The NOA number preceded by the words Miami-Dade County, Florida, and followed by the expiration date may be displayed in advertising literature. If any portion of the NOA is displayed, then it shall be done in its entirety.

INSPECTION: A copy of this entire NOA shall be provided to the user by the manufacturer or its distributors and shall be available for inspection at the job site at the request of the Building Official.

This NOA consists of pages 1 through 6.

The submitted documentation was reviewed by *Freddy Semino* 



NOA No.: 19-0304.01
Expiration Date: 06/27/24
Approval Date: 06/27/19
Page 1 of 6

ROOFING ASSEMBLY APPROVAL

Category: Roofing
Sub-Category: Roofing Tiles
Material: Clay

1. SCOPE

This approves a roofing system using Claymex Brick & Tile Inc, “Spanish” Clay Roof Tile, as manufactured by LAMINADOS DE BARRO S.A DE C.V. and distributed by CLAYMEX BRICK & TILE INC. as described in Section 2 of this Notice of Acceptance. For locations where the pressure requirements, as determined by applicable Building Code does not exceed the design pressure values obtained by calculations in compliance with RAS 127 using the values listed in section 4 herein. The attachment calculations shall be done as a moment based system.

2. PRODUCT DESCRIPTION

<u>Manufactured by Applicant</u>	<u>Dimensions</u>	<u>Test Specifications</u>	<u>Product Description</u>
Claymex Brick & Tile Inc, “Spanish” Clay Roof Tile	Length: 16” Width 9 5/8” 0.50” thick nominal Height 3”	ASTM C 1167 Type I Grade 1	Spanish S Type interlocking, vitrified clay roof tile equipped with one nail hole. For direct deck, nail-on, applications only.
Trim Pieces	l = varies w = varies varying thickness	ASTM C 1167	Accessory trim, clay roof pieces for use at hips, rakes, ridges and valley terminations. Manufactured for each tile profile.

2.1 MANUFACTURING LOCATION

1. Piedras Negras, Coahuila; Mexico

2.2 SUBMITTED EVIDENCE:

<u>Test Agency</u>	<u>Test Identifier</u>	<u>Test Name/Report</u>	<u>Date</u>
Fenestration Testing Laboratory Inc.	10343	TAS 102	08/03/2018
	10259	TAS 102A	08/03/2018
	10095	ASTM C1167	07/20/2018
	10094	TAS 100	07/20/2018



NOA No.: 19-0304.01
 Expiration Date: 06/27/24
 Approval Date: 06/27/19
 Page 2 of 6

3. LIMITATIONS

- 3.1 Fire classification is not part of this acceptance.
- 3.2 For mortar or adhesive set tile applications, a static field uplift test shall be performed in accordance with TAS 106.
- 3.3 Applicant shall retain the services of a Miami-Dade County Certified Laboratory to perform quarterly test in accordance with TAS 112, appendix 'A'. Such testing shall be submitted to the Building Code Compliance Office for review.
- 3.4 Minimum underlayment shall be in compliance with the applicable Roofing Applications Standards listed section 4.1 herein.
- 3.5 30lb anchor sheet underlayment and Polystick TU Plus as a Top Ply applications may be installed perpendicular to the roof slope unless stated otherwise by the underlayment material manufacturers published literature.
- 3.6 This acceptance is for wood deck applications. Minimum deck requirements shall be in compliance with applicable building code.
- 3.7 All products listed herein shall have a quality assurance audit in accordance with the Florida Building Code and Rule 61G20-3 of the Florida Administrative Code.



4. INSTALLATION

- 4.1 Claymex Brick & Tile Inc, "Spanish" Clay Roof Tile, and its components shall be installed in strict compliance with Roofing Application Standard RAS 118 and RAS 119. **DIRECT DECK ONLY**
- 4.2 Only approved underlayment system for use with this tile NOA; consists of, 30lb ASTM D226, Type II anchor sheet and Polyglass TU top ply.
- 4.3 Data For Attachment Calculations

Table 1: Average Weight (W) and Dimensions (l x w)

Tile Profile	Weight-W (lbf)	Length-l (ft.)	Width-w (ft.)
"Spanish " Tile	6.10	1.33	0.80

Table 2: Aerodynamic Multipliers - λ (ft³)

Tile Profile	λ (ft. ³) Batten Application	λ (ft. ³) Direct Deck Application
"Spanish " Tile	N/A	0.221

Table 3: Restoring Moments due to Gravity - M_g (ft.-lbf)

Tile Profile	3":12"	4":12"	5":12"	6":12"	7":12"or greater
	N/A	Direct Deck 4.27	Direct Deck 4.18	Direct Deck 4.07	Direct Deck 3.95
"Spanish " Tile					
Mechanically attached systems, without clip					

Table 3: Restoring Moments due to Gravity - M_g (ft.-lbf)

Tile Profile	3":12"	4":12"	5":12"	6":12"	7":12"or greater
	N/A	Direct Deck 4.30	Direct Deck 4.20	Direct Deck 4.09	Direct Deck 3.97
"Spanish " Tile					
Mechanically attached systems, clipped.					



Table 6: Attachment Resistance Expressed as a Moment M_f (ft.-lbf) for Mechanically Attached Systems		
Tile Profile	Tile Application	Minimum Attachment Resistance
"Spanish S" Tile	One #8 by 2" ½ long Corrosion Resistant Screw	16.72
	One #8 by 2" ½ long Corrosion Resistant Screw W/clip	53.47

5. LABELING

All tiles shall bear the imprint or identifiable marking of the manufacturer's name or logo (See **Detail Below**), or following statement: "Miami-Dade County Product Control Approved"

**LABASA – Laminados de Barro – Mexico
Piedras Negras – PORTUGUESA®**

IDENTIFICATION MARK FOR : Claymex Brick & Tile Inc, "Spanish " Clay Roof Tile

(LOCATED ON UNDERSIDE OF TILE)

6. BUILDING PERMIT REQUIREMENTS

- 6.1 Application for building permit shall be accompanied by copies of the following:
- 6.2 This Notice of Acceptance.
- 6.3 Any other documents required by the Building Official or applicable building code in order to properly evaluate the installation of this system.



NOA No.: 19-0304.01
 Expiration Date: 06/27/24
 Approval Date: 06/27/19
 Page 5 of 6

PROFILE DRAWINGS

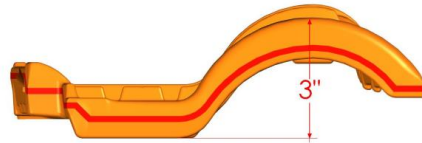
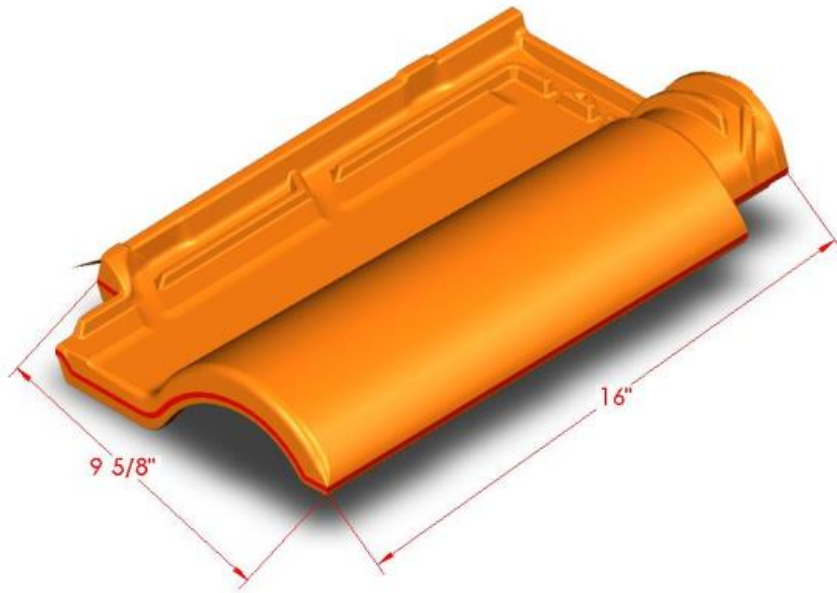

Claymex Brick & Tile Inc. "Spanish S" Clay Roof Tile

END OF THIS ACCEPTANCE



NOA No.: 19-0304.01
Expiration Date: 06/27/24
Approval Date: 06/27/19
Page 6 of 6