



MIAMI-DADE COUNTY
 PRODUCT CONTROL SECTION
 11805 SW 26 Street, Room 208
 Miami, Florida 33175-2474
 T (786) 315-2590 F (786) 315-2599
www.miamidade.gov/economy

DEPARTMENT OF REGULATORY AND ECONOMIC RESOURCES (RER)
 BOARD AND CODE ADMINISTRATION DIVISION
NOTICE OF ACCEPTANCE (NOA)

Dryvit Systems, Inc.
One Energy Way
West Warwick, RI 02893

SCOPE: This NOA is being issued under the applicable rules and regulations governing the use of construction materials. The documentation submitted has been reviewed and accepted by Miami-Dade County RER-Product Control Section to be used in Miami Dade County and other areas where allowed by the Authority Having Jurisdiction (AHJ). This NOA shall not be valid after the expiration date stated below. The Miami-Dade County Product Control Section (In Miami Dade County) and/or the AHJ (in areas other than Miami Dade County) reserve the right to have this product or material tested for quality assurance purposes. If this product or material fails to perform in the accepted manner, the manufacturer will incur the expense of such testing and the AHJ may immediately revoke, modify, or suspend the use of such product or material within their jurisdiction. RER reserves the right to revoke this acceptance, if it is determined by Miami-Dade County Product Control Section that this product or material fails to meet the requirements of the applicable building code. This product is approved as described herein, and has been designed to comply with the Florida Building Code, including the High Velocity Hurricane Zone.

DESCRIPTION: Dryvit Outsulation and Outsulation Plus MD EIF Systems over 1/2” Glass Mat Gypsum Sheathing

APPROVAL DOCUMENT: Drawing No. OSOPL12C1177, titled “Outsulation/Outsulation Plus MD with Panzer 20 over 3-5/8” Studs with 1/2” ASTM C1177 Sheathing”, sheets 1 through 3 of 3, prepared by Dryvit Systems, Inc, dated 02/24/2014, signed and sealed by Scott Wolters, P.E., bearing the Miami-Dade County Product Control renewal stamp with the Notice of Acceptance number and expiration date by the Miami-Dade County Product Control Section.

MISSILE IMPACT RATING: Large and Small Missile Impact Resistant

LABELING: Each unit shall bear a permanent label with the manufacturer's name or logo, Columbus, GA, model/series, and following statement: "Miami-Dade County Product Control Approved", unless otherwise noted herein. Components of this product come in different size buckets or drums. Each container needs to be labeled. Unit is further defined as each individual board of insulation and roll of reinforcing mesh.

RENEWAL of this NOA shall be considered after a renewal application has been filed and there has been no change in the applicable building code negatively affecting the performance of this product.

TERMINATION of this NOA will occur after the expiration date or if there has been a revision or change in the materials, use, and/or manufacture of the product or process. Misuse of this NOA as an endorsement of any product, for sales, advertising or any other purposes shall automatically terminate this NOA. Failure to comply with any section of this NOA shall be cause for termination and removal of NOA.

ADVERTISEMENT: The NOA number preceded by the words Miami-Dade County, Florida, and followed by the expiration date may be displayed in advertising literature. If any portion of the NOA is displayed, then it shall be done in its entirety.

INSPECTION: A copy of this entire NOA shall be provided to the user by the manufacturer or its distributors and shall be available for inspection at the job site at the request of the Building Official. This NOA **renews NOA #17-0807.12** and consists of this page 1 and evidence pages E-1 and E-2, as well as approval document mentioned above.

The submitted documentation was reviewed by **Carlos M. Utrera, P.E.**



Handwritten signature and date: 08/20/2019

NOA No. 19-0808.01
 Expiration Date: September 18, 2024
 Approval Date: August 29, 2019
 Page 1

NOTICE OF ACCEPTANCE: EVIDENCE SUBMITTED

1. Evidence submitted under NOA #14-0610.04

A. DRAWINGS

1. Drawing No. **OSOPL12C1177**, titled "Outsulation/Outsulation Plus MD with Panzer 20 over 3-5/8" Studs with 1/2" ASTM C1177 Sheathing", sheets 1 through 3 of 3, prepared by Dryvit Systems, Inc, dated 02/24/2014, signed and sealed by Scott Wolters, P.E.

B. TESTS

1. Test reports on
 - 1) Air Infiltration Test, per FBC, TAS 202-94
 - 2) Uniform Static Air Pressure Test, Loading per FBC TAS 202-94
 - 3) Water Resistance Test, per FBC, TAS 202-94
 - 4) Large Missile Impact Test per FBC, TAS 201-94
 - 5) Cyclic Wind Pressure Loading per FBC, TAS 203-94along with marked-up drawings and installation diagram of Outsulation/Outsulation Plus MD EIF Systems with ASTM C1177 Sheathing, prepared by Architectural Testing, Inc, Report No. **D4124.01-550-18**, dated 02/28/2014, signed and sealed by Vinu J. Abraham, P.E.

C. CALCULATIONS

1. Anchorage to studs calculations prepared by Wolters Engineering, Inc, dated 05/01/2014, signed and sealed by Scott Wolters, P.E.

D. QUALITY ASSURANCE

1. Miami-Dade Department of Regulatory and Economic Resources (RER)

E. MATERIAL CERTIFICATIONS

1. None.

F. STATEMENTS

1. Statement letter of code conformance to 5th edition (2014) FBC issued by Wolters Engineering, Inc, dated 05/01/2014, signed and sealed by Scott Wolters, P.E.
2. No financial interest letter issued by Wolters Engineering, Inc, dated 05/01/2014, signed and sealed by Scott Wolters, P.E.



08/20/2019

Carlos M. Utrera, P.E.
Product Control Examiner
NOA No. 19-0808.01
Expiration Date: September 18, 2024
Approval Date: August 29, 2019

NOTICE OF ACCEPTANCE: EVIDENCE SUBMITTED

2. New evidence submitted

A. DRAWINGS

1. None.

B. TESTS

1. None.

C. CALCULATIONS

1. None.

D. QUALITY ASSURANCE

1. Miami-Dade Department of Regulatory and Economic Resources (RER)

E. MATERIAL CERTIFICATIONS

1. None.

F. STATEMENTS

1. Statement letter of code conformance to the 6th Edition (2017) FBC issued by Wolters Engineering, Inc, dated 07/16/2019, signed and sealed by Scott Wolters, P.E.



Carlos M. Utrera, P.E.
Product Control Examiner
NOA No. 19-0808.01
Expiration Date: September 18, 2024
Approval Date: August 29, 2019

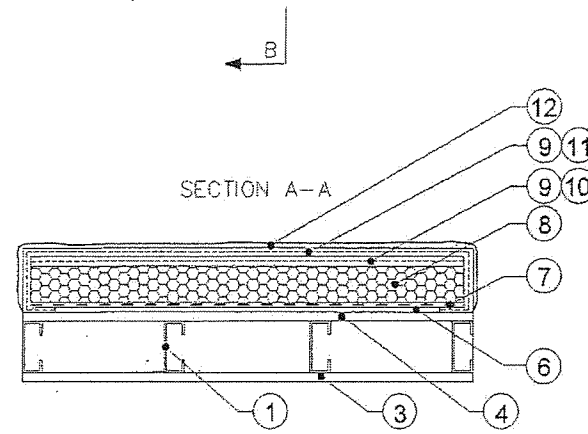
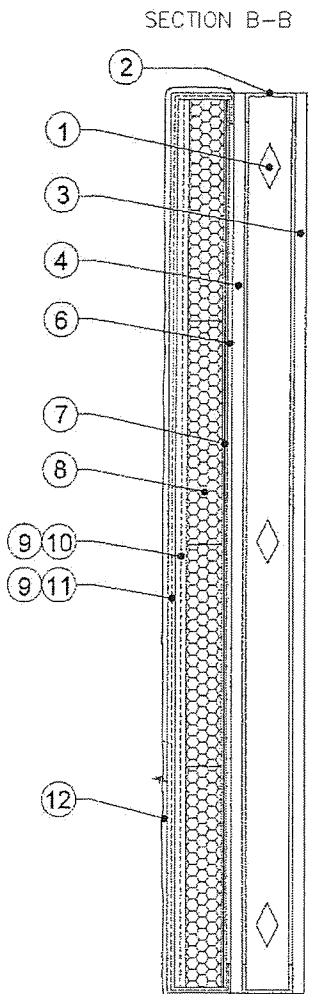
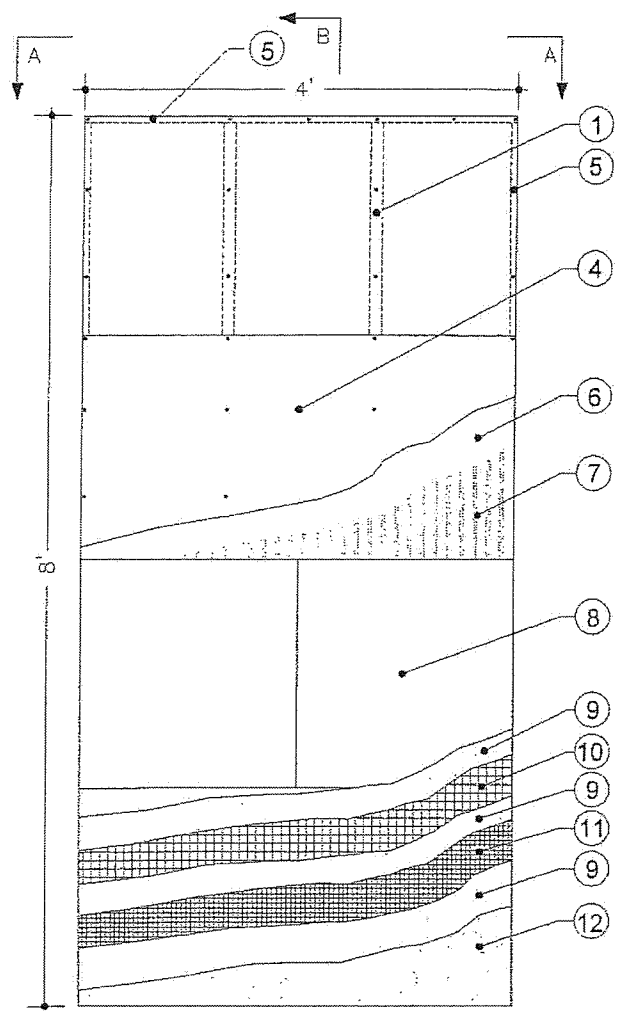

MATERIAL LIST

- ① 3⁵/₈" x 18 GAUGE STEEL STUDS AT 16" O.C.
- ② 3⁵/₈" x 18 GAUGE STEEL TRACK
- ③ 1/2" GYPSUM WALLBOARD
- ④ 1/2" ASTM C 1177 SHEATHING
- ⑤ NO. 6 x 1 1/4" SELF DRILLING SCREWS SPACED AT 6" O.C.
- ⑥ DRYVIT BACKSTOP® NT REQUIRED FOR OUTSULATION PLUS MD SYSTEM.
- ⑦ ADHERE THE EXPANDED POLYSTYRENE (EPS) INSULATION BOARD WITH DRYVIT'S PRIMUS, GENESIS, OR GENESIS DM MIXTURE. THE ADHESIVE IS APPLIED WITH A 3/8" X 1/2" NOTCHED TROWEL WITH NOTCHES SPACED A MAXIMUM OF 1 1/2" O.C. THE ADHESIVE SHALL BE APPLIED TO THE BACKSIDE OF THE EPS IN A VERTICAL ORIENTATION.
- ⑧ MINIMUM 1" THICK INSULATION BOARD MEETING THE FBC SECTION 2612. INSULATION BOARD SUPPLIER SHALL POSSESS A CURRENT NOA WITH MIAMI DADE COUNTY.
- ⑨ DRYVIT BASE COAT: PRIMUS®, GENESIS®, OR GENESIS® DM. PRIMUS OR GENESIS IS MIXED 1:1 BY WEIGHT WITH PORTLAND CEMENT AND WATER. PRIMUS AND GENESIS ARE 100% POLYMER-BASED PRODUCTS. GENESIS DM IS A DRY MIX THAT IS MIXED WITH WATER.
- ⑩ DRYVIT PANZER® 20 REINFORCING MESH 20.5 OZ/YD² FIBERGLASS REINFORCING MESH EMBEDDED IN THE DRYVIT BASE COAT. PANZER 20 MESH EDGES SHALL BE ABUTTED TIGHTLY. DO NOT OVERLAP.
- ⑪ DRYVIT'S STANDARD REINFORCING MESH: 4.3 OZ/YD² FIBERGLASS REINFORCING MESH EMBEDDED IN DRYVIT BASE COAT. THE STANDARD REINFORCING MESH SHALL BE LAPPED A MINIMUM OF 2 1/2" AT ALL EDGES.
- ⑫ DRYVIT FINISH: A 100% ACRYLIC BASED MATERIAL AVAILABLE IN VARIOUS TEXTURES.

GENERAL NOTES

- 1. THE SYSTEM HAS BEEN DESIGNED IN ACCORDANCE WITH THE LATEST EDITION OF THE FLORIDA BUILDING CODE INCLUDING THE LATEST SUPPLEMENTS.
- 2. THIS SYSTEM HAS BEEN TESTED IN ACCORDANCE WITH DADE COUNTY PROTOCOLS TAS-201, TAS-202, AND TAS-203; IMPACT, STRUCTURAL AND CYCLIC TESTING.
- 3. THIS SYSTEM SHALL BE APPLIED BY A LICENSED PLASTERING CONTRACTOR FOLLOWING THIS NOTICE OF ACCEPTANCE THE RECOMMENDATION OF DRYVIT SYSTEMS, INC. AND THE APPLICABLE SECTIONS OF THE FLORIDA BUILDING CODE.
- 4. THE ENGINEER AND/OR ARCHITECT OF RECORD FOR EACH PROJECT USING THIS SYSTEM SHALL SIZE ALL STUD FRAMING TO ENSURE CONFORMANCE WITH STUD DEFLECTION AND STRESS LIMITATIONS AS REQUIRED BY ALL GOVERNING CODES AND THIS DOCUMENT.
- 5. INSULATION BOARDS SHALL BE POSITIONED IN A RUNNING BOND PATTERN.
- 6. ALL STUDS USED WITH THIS SYSTEM SHALL BE COMPLETELY SHEATHED AT THE INTERIOR FLANGE OR BRIDGED AT A MAXIMUM OF EVERY 5' OF STUD LENGTH OR AS SPECIFIED BY THE STUD MANUFACTURER.
- 7. ALL STEEL STUDS SHALL BE STRUCTURAL WITH 1 5/8" MINIMUM FLANGE WIDTH AND HAVE A MINIMUM YIELD STRENGTH OF 33000 PSI.
- 8. DETAILS ON SHEET 2 AND 3 OF 3 ARE TYPICAL AND SHOW INTENT TO PREVENT WATER INFILTRATION INTO AND BEHIND THIS SYSTEM. ALTERNATE DETAILS AND SPECIFIC CONDITIONS NOT COVERED BY THE TYPICAL DETAILS ARE THE RESPONSIBILITY OF THE LICENSED DESIGN PROFESSIONALS.

PRODUCT RENEWED
 as complying with the Florida Building Code
 NOA-No. **19-0808.01**
 Expiration Date **09/18/2024**
 By *[Signature]*
 Miami-Dade Product Control

PRODUCT REVISED
 as complying with the Florida Building Code
 NOA-No. **17-0807.12**
 Expiration Date **09/18/2019**
 By *[Signature]*
 Miami-Dade Product Control

Approved as complying with the Florida Building Code
 Date **09/18/2014**
 NOA# **14-0610.04**
 Miami Dade Product Control
 By *[Signature]*

SCOTT WOLTERS
 FL PE# 62354
 WOLTERS ENGINEERING
 (COA# 27194)
 1725 SW 25TH AVENUE
 FT. LAUDERDALE, FL 33312
 PH/FAX: (954) 583-0946
 SEAL: *[Signature]*
 MAY 01 2014

DESIGN PRESSURE
±70 PSF

DRYVIT SYSTEMS, INC.		
One Energy Way West Warwick, Rhode Island		
DWG. NO.: 050PL12C1177-358STUDS		
SHEET NO: 1 OF 3	ISSUE DATE: 2/24/2014	REV / DATE:
OUTSULATION/OUTSULATION PLUS MD WITH PANZER 20 OVER 3 5/8" STUDS WITH 1/2" ASTM C 1177 SHEATHING		

PRODUCT RENEWED
 as complying with the Florida
 Building Code
 NOA-No. 19-0808.01

Expiration Date 09/18/2024

By [Signature]
 Miami-Dade Product Control

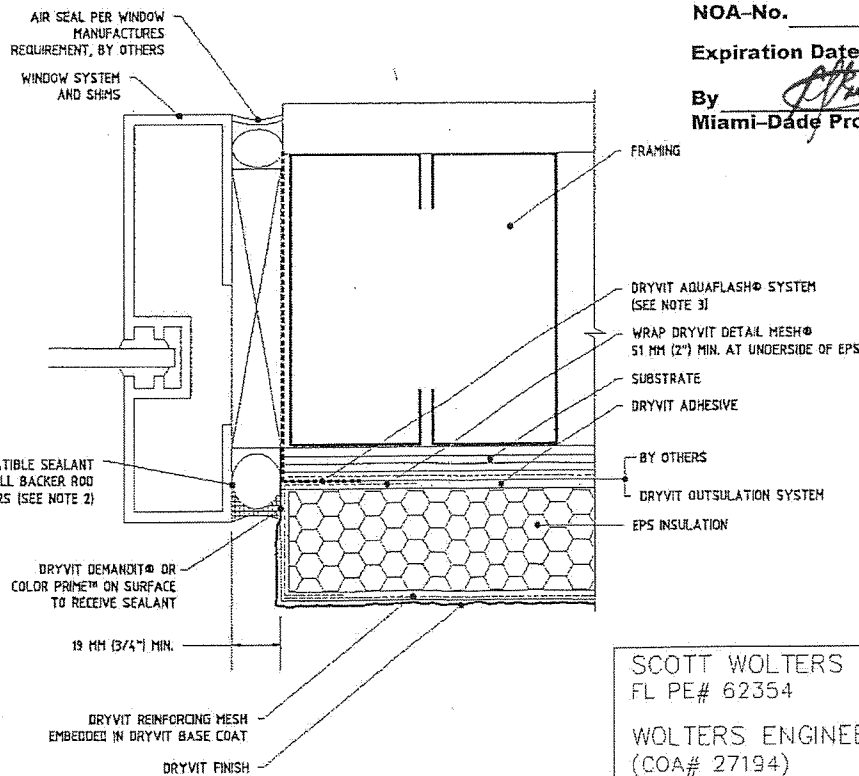
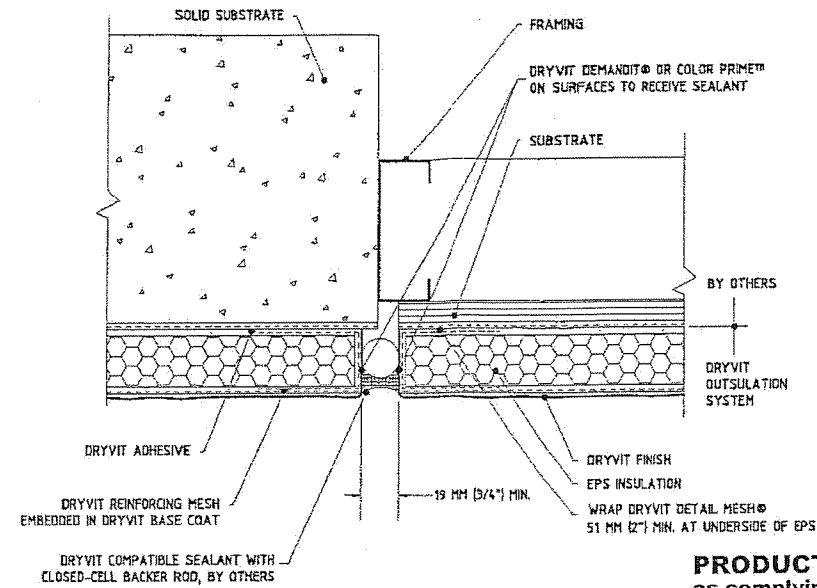
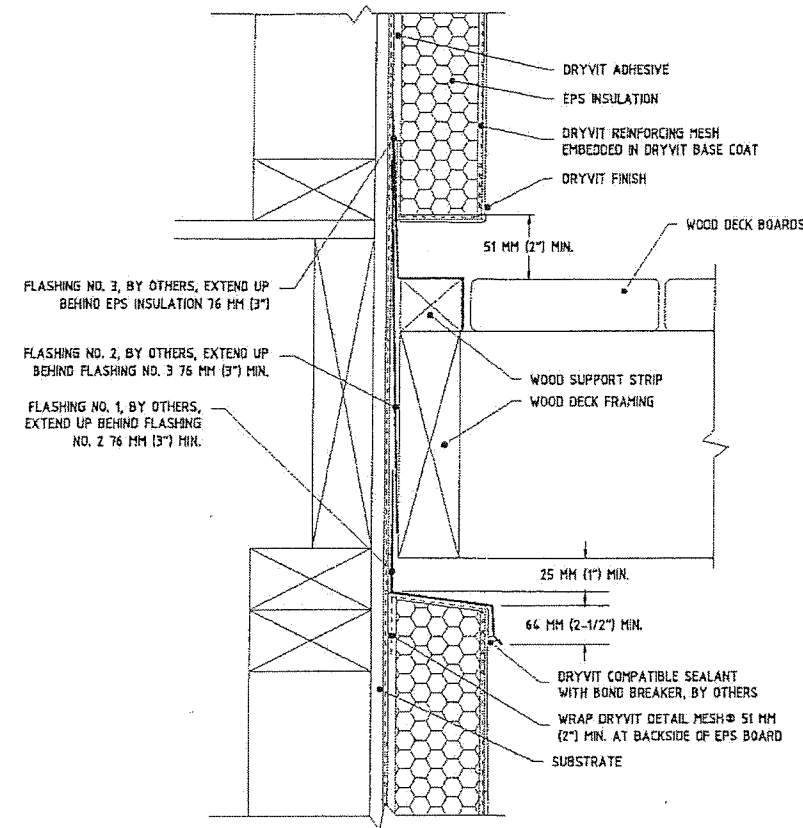
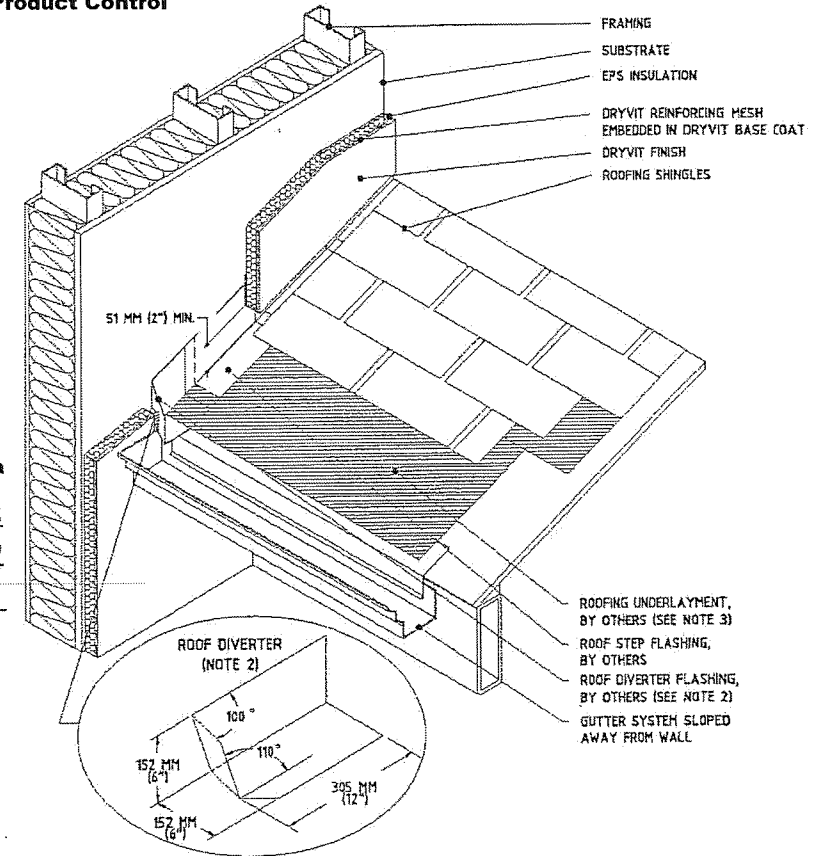

PRODUCT REVISED
 as complying with the Florida
 Building Code
 NOA-No. 17-0807.12

Expiration Date 09/18/2019

By [Signature]
 Miami-Dade Product Control

Approved as complying with the
 Florida Building Code
 Date 09/18/2014
 NOA# 14-0610.04
 Miami Dade Product Control

By [Signature]

NOTES:

- GAP WOOD SHEATHING EDGE AND END JOINTS IN ACCORDANCE WITH APA (AMERICAN PLYWOOD ASSOCIATION) RECOMMENDATIONS.
- SEAL PENETRATIONS THROUGH FLASHING WHERE ATTACHED TO FRAMING.
- DISTANCE OF EIFS TO DECK VARIES WITH CLIMATE. ALLOW SUFFICIENT DISTANCE TO PREVENT SNOW/ICE AND PUDDLING WATER AGAINST SYSTEM.
- PROVIDE END DAMS WHERE FLASHINGS TERMINATE AT ENDS OF DECK.
- PRESSURE TREATED WOOD (SPACE FROM FLASHING OR ROUT BACKSIDE TO PROVIDE DRAINAGE

DESIGN PRESSURE
 ±70 PSF

SCOTT WOLTERS
 FL PE# 62354
 WOLTERS ENGINEERING
 (COA# 27194)
 1725 SW 25TH AVENUE
 FT. LAUDERDALE, FL 33312
 PH/FAX: (954) 583-0946
 SEAL: [Signature]
 MAY 01 2014

DRYVIT SYSTEMS, INC.
 One Energy Way
 West Warwick, Rhode Island
 DWG. NO.: OSOPL12C1177-358STUDS
 SHEET NO: 2 OF 3
 ISSUE DATE: 2/24/2014
 REV / DATE:
 OUTSULATION/OUTSULATION PLUS MD WITH PANZER 20 OVER 3/8" STUDS WITH 1/2 ASTM C 1177 SHEATHING

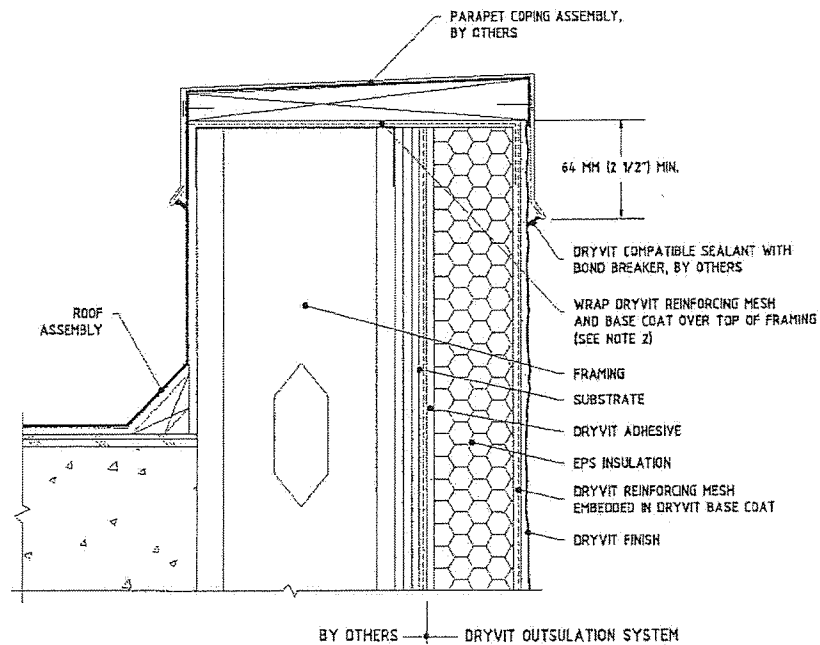
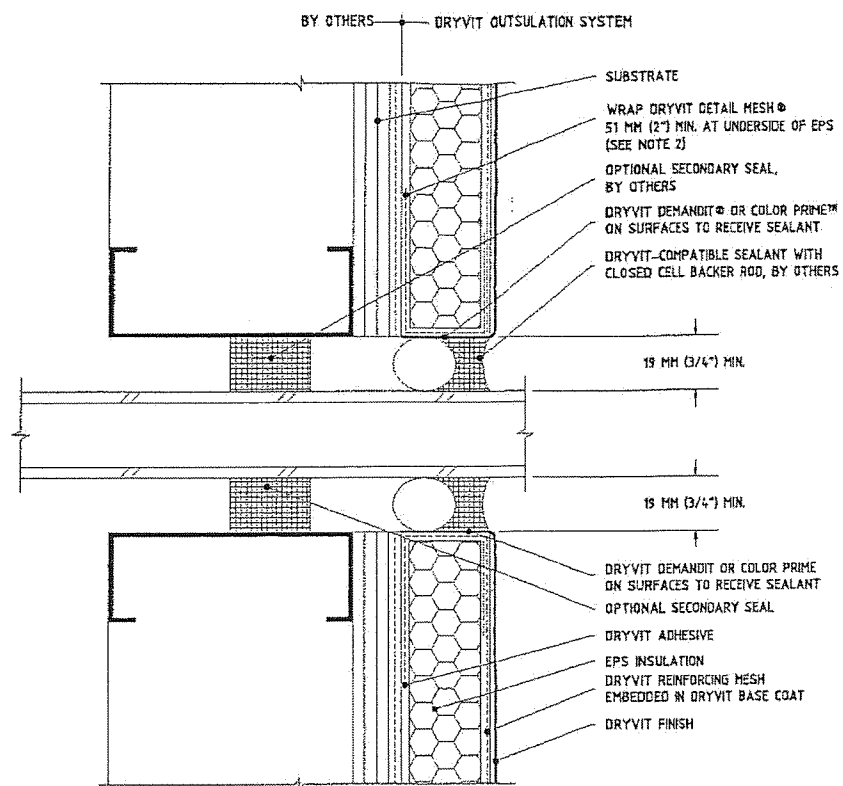
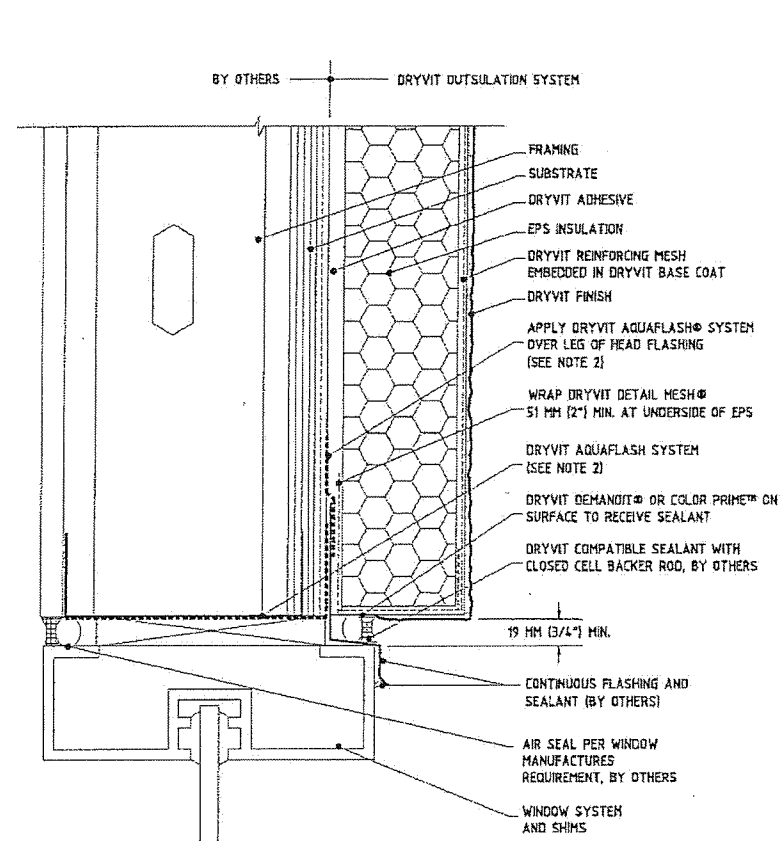

PRODUCT RENEWED
as complying with the Florida
Building Code

NOA-No. 19-0808.01

Expiration Date 09/18/2024

By [Signature]
Miami-Dade Product Control

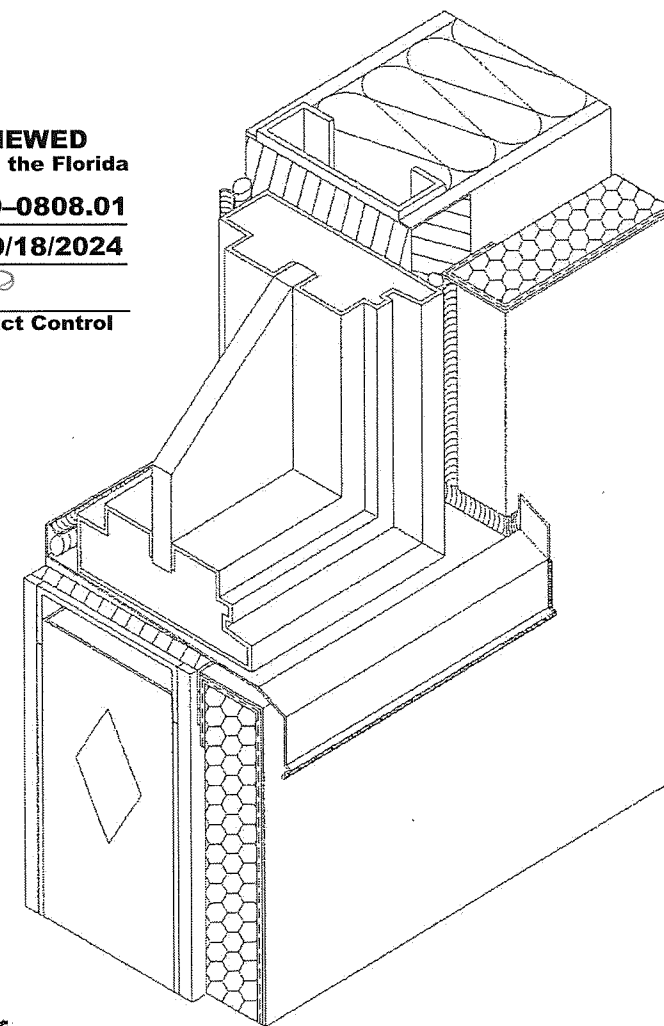

PRODUCT REVISED
as complying with the Florida
Building Code

NOA-No. 17-0807.12

Expiration Date 09/18/2019

By [Signature]
Miami-Dade Product Control

Approved as complying with the
Florida Building Code
Date 09/18/2014
NOA# 14-0610.04
Miami-Dade Product Control

By [Signature]

DESIGN PRESSURE

±70 PSF

SCOTT WOLTERS
FL PE# 62354
WOLTERS ENGINEERING
(COA# 27194)
1725 SW 25TH AVENUE
FT. LAUDERDALE, FL 33312
PH/FAX: (954) 583-0946

SEAL:
[Signature]

MAY 01 2014

DRYVIT SYSTEMS, INC. 
One Energy Way
West Warwick, Rhode Island

DWG. NO.:
OSOPL12C1177-3585STUDS

SHEET NO: 3 OF 3
ISSUE DATE: 2/24/2014
REV / DATE:

OUTSULATION/OUTSULATION PLUS MD WITH PANZER 20
OVER 3/8" STUDS WITH 1/2" ASTM C 1177 SHEATHING