



DEPARTMENT OF REGULATORY AND ECONOMIC RESOURCES (RER)
BOARD AND CODE ADMINISTRATION DIVISION

MIAMI-DADE COUNTY
PRODUCT CONTROL SECTION
11805 SW 26 Street, Room 208
Miami, Florida 33175-2474
T (786) 315-2590 F (786) 315-2599
www.miamidade.gov/economy

NOTICE OF ACCEPTANCE (NOA)

Brava I.P. LLC
PO Box 714
Neenah, WI 54957-0714

SCOPE:

This NOA is being issued under the applicable rules and regulations governing the use of construction materials. The documentation submitted has been reviewed and accepted by Miami-Dade County RER - Product Control Section to be used in Miami Dade County and other areas where allowed by the Authority Having Jurisdiction (AHJ).

This NOA shall not be valid after the expiration date stated below. The Miami-Dade County Product Control Section (In Miami Dade County) and/or the AHJ (in areas other than Miami Dade County) reserve the right to have this product or material tested for quality assurance purposes. If this product or material fails to perform in the accepted manner, the manufacturer will incur the expense of such testing and the AHJ may immediately revoke, modify, or suspend the use of such product or material within their jurisdiction. RER reserves the right to revoke this acceptance, if it is determined by Miami-Dade County Product Control Section that this product or material fails to meet the requirements of the applicable building code.

This product is approved as described herein, and has been designed to comply with the Florida Building Code including the High Velocity Hurricane Zone of the Florida Building Code.

DESCRIPTION: Brava Old World Spanish A4 Composite Tile

LABELING: Each unit shall bear a permanent label with the manufacturer's name or logo, city, state and following statement: "Miami-Dade County Product Control Approved", unless otherwise noted herein.

RENEWAL of this NOA shall be considered after a renewal application has been filed and there has been no change in the applicable building code negatively affecting the performance of this product.

TERMINATION of this NOA will occur after the expiration date or if there has been a revision or change in the materials, use, and/or manufacture of the product or process. Misuse of this NOA as an endorsement of any product, for sales, advertising or any other purposes shall automatically terminate this NOA. Failure to comply with any section of this NOA shall be cause for termination and removal of NOA.

ADVERTISEMENT: The NOA number preceded by the words Miami-Dade County, Florida, and followed by the expiration date may be displayed in advertising literature. If any portion of the NOA is displayed, then it shall be done in its entirety.

INSPECTION: A copy of this entire NOA shall be provided to the user by the manufacturer or its distributors and shall be available for inspection at the job site at the request of the Building Official.

This renews NOA #18-0919.03 and consists of pages 1 through 7.
The submitted documentation was reviewed by *Freddy Semino*



NOA No.: 20-0330.01
Expiration Date: 09/18/24
Approval Date: 10/01/20
Page 1 of 7

ROOFING ASSEMBLY APPROVAL

Category: Roofing
Sub-Category: Roofing Tile
Materials: Composite
Deck Type: Wood
Maximum Design Pressure -114.25 psf.
Fire Classification Pressure See General Limitation #1

TRADE NAMES OF PRODUCTS MANUFACTURED OR LABELED BY APPLICANT:

<u>Product</u>	<u>Dimensions</u>	<u>Test Specifications</u>	<u>Product Description</u>
Brava Old World Spanish A4 Composite Tile	Length: 16-1/2" Width: 13" Height: 2-1/8"	TAS 125	Barrel shaped composite tile for use in mechanically attached systems.

MANUFACTURING LOCATION:

1. Washington, IA.

EVIDENCE SUBMITTED:

<u>Test Agency</u>	<u>Test Identifier</u>	<u>Test Name/Report</u>	<u>Date</u>
Intertek	J4657.02-106-18 RO	ASTM D 2843	12/02/19
	J4657.02-106-18 RO	ASTM D 1929	12/02/19
	J4657.02-106-18 RO	ASTM D 635	12/02/19
PRI Construction Materials Technologies	TMIC-001-02-01	ASTM G 155	06/29/07
	TMIC-007-02-01	TAS 100	10/05/07
Southwest Research Institute Hurricane Test Laboratory, LLC.	01.12694.01.306a	ASTM E 108	02/12/07
	0497-0201-08	TAS 125	05/16/08



NOA No.: 20-0330.01
Expiration Date: 09/18/24
Approval Date: 10/01/20
Page 2 of 7

APPROVED ASSEMBLIES:

System:	Brava Old World Spanish A4 Composite Tile
Deck Type:	Wood, Non-Insulated
Deck Description:	¹⁹ / ₃₂ " or greater plywood or wood plank.
Slope Range:	2": 12" or greater
Maximum Uplift Pressure:	See Maximum Design Pressures Below

Deck Attachment:	In accordance with applicable building code, but in no case shall it be less than # 8d annular ring shank nails spaced 6" o.c. In reroofing, where the deck is less than ¹⁹ / ₃₂ " thick (Minimum ¹⁵ / ₃₂ ") the above attachment method must be in addition to existing attachment.
Underlayment:	Minimum underlayment shall be an ASTM D 226 Type II installed with a minimum 4" side-lap and 6" end-laps. Underlayment shall be fastened with corrosion resistant tin-caps and 12 gauge 1 ¼" annular ring-shank nails, spaced 6" o.c. at all laps and two staggered rows 12" o.c. in the field of the roll. Or, any approved underlayment having a current NOA.
Fire Barrier:	Any approved fire barrier having a current NOA. Refer to a current fire directory listing for fire ratings of this roofing system assembly as well as the location of the fire barrier within the assembly. See Limitation # 1.
Valleys:	Valley construction shall be in compliance with Roofing Application Standard RAS 118 and with Brava Technologies LLC's current published installation instructions.
Starter:	Install starter over the 1" thick cant strip and fasten with two (2) #10 screws in the designated nail holes.
Tile Installation (Field Condition):	<p>Install the "Brava Old World Spanish A4 Composite Tile" and accessories in compliance with the current published installation instructions and details in Brava Technologies LLC's Installation Manual. Flashings, penetrations, valley construction and other details shall be constructed in compliance with Roofing Application Standard RAS 133.</p> <p>Each panel is installed with (2) two 1/8" diameter corrosion resistant roofing nails of sufficient length to penetrate through the sheathing a minimum 3/16" of an inch, through the designated nail holes. (See Detail A)</p> <p>The adjoining tile is laid next to the existing tile overlapping the edge. The next row is laid with a 13" exposure. (See Detail B)</p>
Maximum Design Pressure (Field Condition):	-91.75psf (See General Limitation #2)

**Tile Installation
(Perimeter and
Corner Condition):**

Install the "Old World Spanish A4 Composite Tile" and accessories in compliance with the current published installation instructions and details in Brava IP LLC's Installation Manual. Flashings, penetrations, valley construction and other details shall be constructed in compliance with Roofing Application Standard RAS 133.

Each panel is installed with (2) two corrosion resistant #10 screws of sufficient length to penetrate through the sheathing a minimum 3/16" of an inch, through the designated nail holes. (See Detail A)

The adjoining tile is laid next to the existing tile overlapping the edge. The next row is laid with a 13" exposure. (See Detail B)

**Maximum Design
Pressure
(Perimeter and
Corner Condition):**

-114.25psf (See General Limitation #2)



GENERAL LIMITATIONS:

1. Fire classification is not part of this acceptance; refer to a current Approved Roofing Materials Directory for fire ratings of this product.
2. The maximum designed pressure limitation listed shall be applicable to all roof pressure zones (i.e. field, perimeters, and corners). Neither rational analysis, nor extrapolation shall be permitted for enhanced fastening at enhanced pressure zones (i.e. perimeters, extended corners and corners).
3. All shakes shall be permanently labeled with the manufacturer's name and/or logo, and the following statement: "Miami-Dade County Product Control Approved" **or** with the Miami-Dade County Product Control Seal as seen below.



4. All products listed herein shall have a quality assurance audit in accordance with the Florida Building Code and Rule 61G20-3 of the Florida Administrative Code.



PROFILE DRAWINGS

DETAIL A

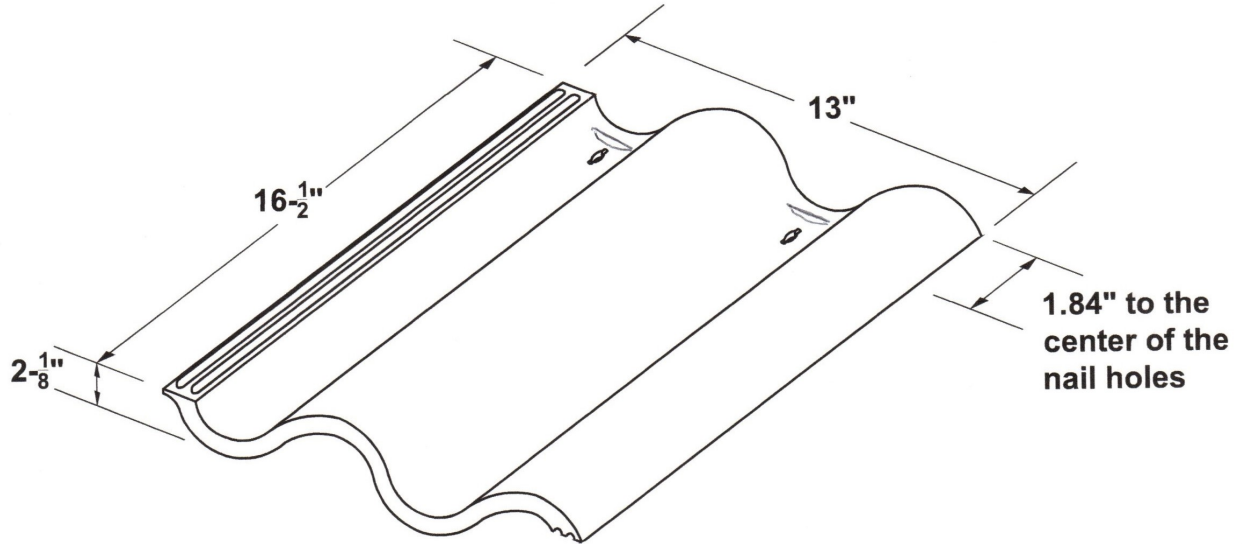

Brava Old World Spanish A4 Composite Tile



DETAIL B

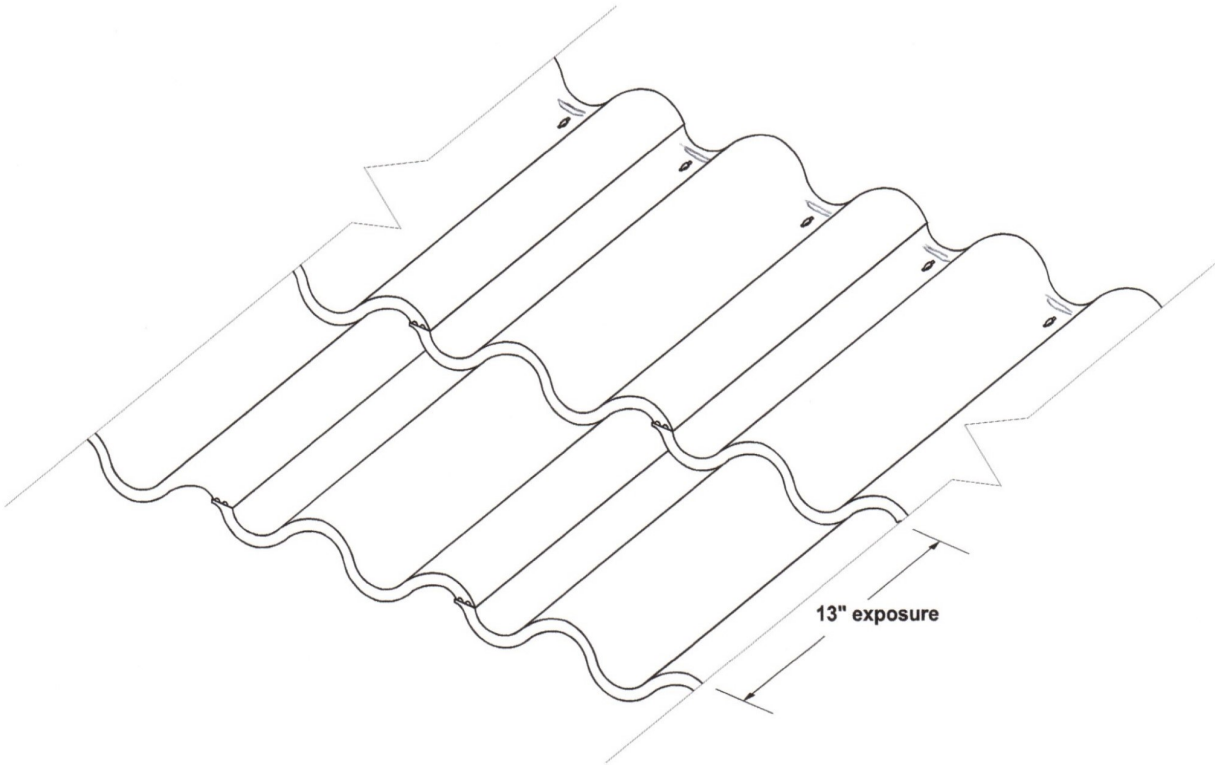

END OF THIS ACCEPTANCE

