



MIAMI-DADE COUNTY  
**PRODUCT CONTROL SECTION**  
 11805 SW 26 Street, Room 208  
 Miami, Florida 33175-2474  
 T (786) 315-2590 F (786) 315-2599  
[www.miamidade.gov/building](http://www.miamidade.gov/building)

**DEPARTMENT OF REGULATORY AND ECONOMIC RESOURCES (RER)  
 BOARD AND CODE ADMINISTRATION DIVISION  
 NOTICE OF ACCEPTANCE (NOA)**

**CGI Windows and Doors, Inc.**  
**3780 W 104<sup>th</sup> Street**  
**Hialeah, FL 33018**

**SCOPE:**

This NOA is being issued under the applicable rules and regulations governing the use of construction materials. The documentation submitted has been reviewed and accepted by Miami-Dade County RER - Product Control Section to be used in Miami Dade County and other areas where allowed by the Authority Having Jurisdiction (AHJ).

This NOA shall not be valid after the expiration date stated below. The Miami-Dade County Product Control Section (In Miami Dade County) and/or the AHJ (in areas other than Miami Dade County) reserve the right to have this product or material tested for quality assurance purposes. If this product or material fails to perform in the accepted manner, the manufacturer will incur the expense of such testing and the AHJ may immediately revoke, modify, or suspend the use of such product or material within their jurisdiction. RER reserves the right to revoke this acceptance if it is determined by Miami-Dade County Product Control Section that this product or material fails to meet the requirements of the applicable building code.

This product is approved as described herein and has been designed to comply with the Florida Building Code, including the High Velocity Hurricane Zone.

**DESCRIPTION: Series "Sentinel 130" Aluminum Fixed Window – L.M.I.**

**APPROVAL DOCUMENT:** Drawing No. **PW130LMI-NOA**, titled "'Sentinel' Series 130 Fixed Window - LM", sheets 1 through 7 of 7, dated 05/22/19, with revision A dated 05/07/20, prepared by manufacturer, signed and sealed by Anthony Lynn Miller, P.E., bearing the Miami-Dade County Product Control Revision stamp with the Notice of Acceptance number and expiration date by the Miami-Dade County Product Control Section.

**MISSILE IMPACT RATING: Large and Small Missile Impact Resistant**

**LABELING:** Each unit shall bear a permanent label with the manufacturer's name or logo, city, state, model/series, and following statement: "Miami-Dade County Product Control Approved", unless otherwise noted herein.

**RENEWAL** of this NOA shall be considered after a renewal application has been filed and there has been no change in the applicable building code negatively affecting the performance of this product.

**TERMINATION** of this NOA will occur after the expiration date or if there has been a revision or change in the materials, use, and/or manufacture of the product or process. Misuse of this NOA as an endorsement of any product, for sales, advertising or any other purposes shall automatically terminate this NOA. Failure to comply with any section of this NOA shall be cause for termination and removal of NOA.

**ADVERTISEMENT:** The NOA number preceded by the words Miami-Dade County, Florida, and followed by the expiration date may be displayed in advertising literature. If any portion of the NOA is displayed, then it shall be done in its entirety.

**INSPECTION:** A copy of this entire NOA shall be provided to the user by the manufacturer or its distributors and shall be available for inspection at the job site at the request of the Building Official.

This NOA **revises and renews NOA# 19-0603.02** and consists of this page 1 and evidence pages E-1, E-2, E-3, E-4 and E-5, as well as approval document mentioned above.

The submitted documentation was reviewed by **Manuel Perez, P.E.**

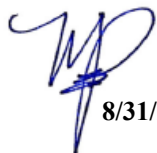

  
 8/31/20

**NOA No. 20-0519.09**  
**Expiration Date: September 22, 2025**  
**Approval Date: October 10, 2020**  
 Page 1

**CGI Windows and Doors, Inc.**

**NOTICE OF ACCEPTANCE: EVIDENCE SUBMITTED**

**1. EVIDENCE SUBMITTED UNDER PREVIOUS NOA's**

**A. DRAWINGS**

1. Manufacturer's die drawings and sections.  
*(Submitted under NOA No. 10-0510.13)*
2. Drawing No. **PW130LMI-NOA**, titled "Sentinel 130 Alum Fixed Window (L.M.I.)(S.M.I.)", sheets 1 through 7 of 7, dated 05/22/19, prepared by manufacturer, signed and sealed by Anthony Lynn Miller, P.E.  
*(Submitted under NOA No.19-0603.02)*

**B. TESTS**

1. Test reports on: 1) Uniform Static Air Pressure Test, Loading per FBC, TAS 202-94  
2) Large Missile Impact Test per FBC, TAS 201-94  
3) Cyclic Wind Pressure Loading per FBC, TAS 203-94  
along with marked-up drawings and installation diagram of a series 560 aluminum sliding glass door, prepared by Fenestration Testing Laboratory, Inc., Test Report No. **FTL-19-8916**, dated 04/10/19, signed and sealed by Idalmis Ortega, P.E.  
*(Submitted under NOA No.19-0603.02)*
2. Test reports on: 1) Uniform Static Air Pressure Test, Loading per FBC, TAS 202-94  
2) Water Resistance Test, per FBC, TAS 202-94  
3) Small Missile Impact Test per FBC, TAS 201-94  
4) Large Missile Impact Test per FBC, TAS 201-94  
5) Cyclic Wind Pressure Loading per FBC, TAS 203-94  
along with marked-up drawings and installation diagram of a series 130 and 410 aluminum fixed windows, prepared by Fenestration Testing Laboratory, Inc., Test Report No. **FTL-19-8917**, dated 04/09/19, signed and sealed by Idalmis Ortega, P.E.  
*(Submitted under NOA No.19-0603.02)*
3. Test reports on: 1) Uniform Static Air Pressure Test, Loading per FBC TAS 202-94  
2) Large Missile Impact Test per FBC, TAS 201-94  
3) Cyclic Wind Pressure Loading per FBC, TAS 203-94  
along with marked-up drawings and installation diagram of a series 7500 PVC fixed window, to qualify DuPont "Butacite" PVB interlayer, Duraseal® and Super Spacer® insulating glass spacer, prepared by Certified Test Laboratories, Test Report No. **CTLA-3056 WA**, dated 03/03/15, signed and sealed by Ramesh C. Patel, P.E.  
*(Submitted under NOA No.15-0413.03)*

  
\_\_\_\_\_  
Manuel Perez, P.E.  
Product Control Examiner  
NOA No. 20-0519.09  
Expiration Date: September 22, 2025  
Approval Date: October 10, 2020

**NOTICE OF ACCEPTANCE: EVIDENCE SUBMITTED**

**1. EVIDENCE SUBMITTED UNDER PREVIOUS NOA's (CONTINUED)**

**B. TESTS (CONTINUED)**

4. Test reports on: 1) Uniform Static Air Pressure Test, Loading per FBC TAS 202-94  
2) Large Missile Impact Test per FBC, TAS 201-94  
3) Cyclic Wind Pressure Loading per FBC, TAS 203-94  
along with marked-up drawings and installation diagram of a series 7400 PVC project out window, to qualify DuPont "Butacite" PVB interlayer, Duraseal® and Super Spacer® insulating glass spacer, prepared by Certified Test Laboratories, Test Report No. **CTLA-3056 WB**, dated 03/03/15, signed and sealed by Ramesh C. Patel, P.E.  
*(Submitted under NOA No.15-0413.03)*
5. Test reports on: 1) Uniform Static Air Pressure Test, Loading per FBC TAS 202-94  
2) Large Missile Impact Test per FBC, TAS 201-94  
3) Cyclic Wind Pressure Loading per FBC, TAS 203-94  
along with marked-up drawings and installation diagram of a series 238 aluminum fixed window, to qualify DuPont "Butacite" PVB interlayer, Duraseal® and Super Spacer® insulating glass spacer, prepared by Certified Test Laboratories, Test Report No. **CTLA-3056 WC**, dated 04/16/15, signed and sealed by Ramesh C. Patel, P.E.  
*(Submitted under NOA No. 15-0413.03)*
6. Test reports on: 1) Air Infiltration Test, per FBC, TAS 202-94  
2) Uniform Static Air Pressure Test, Loading per FBC TAS 202-94  
3) Water Resistance Test, per FBC, TAS 202-94  
4) Small Missile Impact Test per FBC, TAS 201-94  
5) Cyclic Wind Pressure Loading per FBC, TAS 203-94  
along with marked-up drawings and installation diagram of a Sentinel 130 aluminum fixed window, prepared by Hurricane Test Laboratory, Test Report No. **HTL 0080-0130-10**, dated 03/30/10, signed and sealed by Vinu J. Abraham, P.E.  
*(Submitted under NOA No.10-0510.13)*

**C. CALCULATIONS**

1. Anchor verification calculations and structural analysis, complying with **FBC 6<sup>th</sup> Edition (2017)**, dated July 15, 2017, prepared by Al-Farooq Corporation, signed and sealed by Javad Ahmad, P.E.  
*(Submitted under NOA No.17-0918.07)*
2. Glazing complies with **ASTM E1300-09**.

**D. QUALITY ASSURANCE**

1. Miami-Dade Department of Regulatory and Economic Resources (RER)

  
Manuel Perez, P.E.  
Product Control Examiner  
NOA No. 20-0519.09  
Expiration Date: September 22, 2025  
Approval Date: October 10, 2020

**CGI Windows and Doors, Inc.**

**NOTICE OF ACCEPTANCE: EVIDENCE SUBMITTED**

**1. EVIDENCE SUBMITTED UNDER PREVIOUS NOA's (CONTINUED)**

**E. MATERIAL CERTIFICATIONS**

1. Notice of Acceptance No. **17-0808.02** issued to **Kuraray America, Inc.** for their "**SentryGlas® (Clear and White) Glass Interlayers**" dated 12/28/17, expiring on 07/04/23.
2. Notice of Acceptance No. **17-1114.14** issued to **Kuraray America, Inc.** for their "**Trosifol® Ultraclear, Clear and Color PVB Glass Interlayers**" dated 01/18/18, expiring on 07/08/19.
3. Notice of Acceptance No. **18-0301.06** issued to **Eastman Chemical Company (MA)** for their "**Saflex CP - Saflex and Saflex HP Composite Glass Interlayers with PET Core**" dated 05/17/18, expiring on 12/11/23.
4. Notice of Acceptance No. **17-0712.05** issued to **Eastman Chemical Company (MA)** for their "**Saflex Clear and Color Glass Interlayers**" dated 09/07/17, expiring on 05/21/21.

**F. STATEMENTS**

1. Statement letter of conformance, complying with **FBC 6<sup>th</sup> Edition (2017)**, dated May 23, 2019, issued by manufacturer, signed and sealed by A. Lynn Miller, P.E.  
*(Submitted under NOA No.19-0603.02)*
2. Statement letter of no financial interest, dated May 23, 2019, issued by manufacturer, signed and sealed by A. Lynn Miller, P.E.  
*(Submitted under NOA No.19-0603.02)*
3. Proposal No. **19-0219** issued by the Product Control Section, dated March 13, 2019, signed by Ishaq Chanda, P.E.  
*(Submitted under NOA No.19-0603.02)*
4. Notification of Successor Engineer for manufacturer's NOA document per **Section 61G15-27.001** of the **Florida Administrative Code**, notifying original engineer that the successor engineer is assuming full professional and legal responsibility for all engineering documents pertaining to this NOA, dated May 22, 2019, signed and sealed by A. Lynn Miller, P.E.  
*(Submitted under NOA No.19-0603.02)*
5. Laboratory compliance letter for Test Report No. **HTL-0080-0103-10**, issued by Hurricane Test Laboratory, LLC, dated March 30, 2010, signed and sealed by Vinu J. Abraham, P.E.  
*(Submitted under NOA No.10-0510.13)*
6. Test Proposal for the qualification of **Butacite®** PVB glass interlayer by Kuraray America, Inc., as well as **Duraseal®** and **Super Spacer® Standard** warm-edge flexible insulating glass spacers, dated December 16, 2014, issued by RER, Product Control Section, signed by Jaime Gascon, P.E., Supervisor, Product Control Section.  
*(Submitted under NOA No. 15-0413.03)*

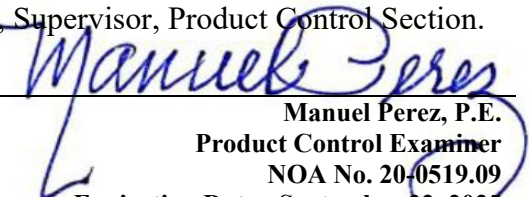
  
Manuel Perez, P.E.  
Product Control Examiner  
NOA No. 20-0519.09  
Expiration Date: September 22, 2025  
Approval Date: October 10, 2020

**CGI Windows and Doors, Inc.**

**NOTICE OF ACCEPTANCE: EVIDENCE SUBMITTED**

**1. EVIDENCE SUBMITTED UNDER PREVIOUS NOA's (CONTINUED)**

**G. OTHERS**

1. Notice of Acceptance No. **17-0918.07**, issued to CGI Windows and Doors, Inc. for their Series "Sentinel 130" Aluminum Fixed Window - L.M.I. approved on 11/22/17 and expiring on 09/22/20.

**2. NEW EVIDENCE SUBMITTED**

**A. DRAWINGS**

1. Drawing No. **PW130LMI-NOA**, titled "'Sentinel' Series 130 Fixed Window - LM", sheets 1 through 7 of 7, dated 05/22/19, with revision A dated 05/07/20, prepared by manufacturer, signed and sealed by Anthony Lynn Miller, P.E.

**B. TESTS**

1. Test reports on: 1) Air Infiltration Test, per FBC, TAS 202-94  
2) Uniform Static Air Pressure Test, Loading per FBC, TAS 202-94  
3) Water Resistance Test, per FBC, TAS 202-94  
4) Large Missile Impact Test per FBC, TAS 201-94  
5) Cyclic Wind Pressure Loading per FBC, TAS 203-94  
6) Forced Entry Test, per ASTM F588 and TAS 202-94

along with marked-up drawings and installation diagram of all PGT Industries, Inc. CGI Windows and Doors, Inc., representative units listed below and tested to qualify **Dowsil 791** and **Dowsil 983** silicones, per Proposal #**19-1155TP**, prepared by Fenestration Testing Laboratory, Inc., Test Reports No.:

**PGT Industries, Inc. test specimens:**

**FTL-7897**, PGT PW5520 PVC Fixed Window (unit 6 in proposal), dated 09/03/14  
**FTL-20-2107.1**, PGT SGD780 Aluminum Sliding Glass Door (unit 7 in proposal)  
**FTL-20-2107.2**, PGT CA740 Alum. Outswing Casement Window (unit 8 in proposal)  
**FTL-20-2107.3**, PGT PW7620A Aluminum Fixed Window (unit 9 in proposal) and  
**FTL-20-2107.4**, PGT PW7620A Aluminum Fixed Window (unit 10 in proposal)  
all dated 07/13/20 and signed and sealed by Idalmis Ortega, P.E.

**CGI Windows and Doors Inc. test specimens:**

**FTL-20-2108.1**, CGI SH360 Aluminum Single Hung Window (unit 1 in proposal)  
**FTL-20-2108.2**, CGI CA238 Alum. Outswing Casement Window (unit 2 in proposal)  
**FTL-20-2108.3**, CGI SGD560 Aluminum Sliding Glass Door (unit 3 in proposal)  
**FTL-20-2108.4**, CGI PW410 Aluminum Fixed Window (unit 4 in proposal) and  
**FTL-20-2108.5**, CGI SH360 Aluminum Single Hung Window (unit 5 in proposal)  
all dated 08/24/20 and signed and sealed by Idalmis Ortega, P.E

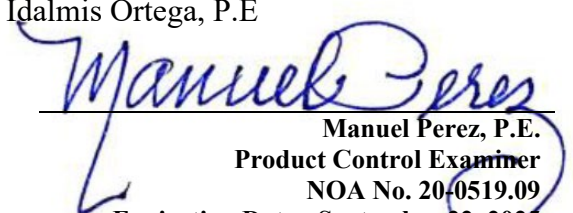
  
Manuel Perez, P.E.  
Product Control Examiner  
NOA No. 20-0519.09  
Expiration Date: September 22, 2025  
Approval Date: October 10, 2020

**CGI Windows and Doors, Inc.**

**NOTICE OF ACCEPTANCE: EVIDENCE SUBMITTED**

**2. NEW EVIDENCE SUBMITTED (CONTINUED)**

**C. CALCULATIONS**

1. Anchor verification calculations and structural analysis, complying with **FBC 6<sup>th</sup> Edition (2017)**, dated 07/15/17, prepared by Al-Farooq Corporation, signed and sealed by Javad Ahmad, P.E., updated to comply with **FBC 7<sup>th</sup> Edition (2020)**, on 05/11/20 by manufacturer, signed and sealed by Anthony Lynn Miller, P.E.

**D. QUALITY ASSURANCE**

1. Miami-Dade Department of Regulatory and Economic Resources (RER)

**E. MATERIAL CERTIFICATIONS**

1. Notice of Acceptance No. **18-0725.11** issued to **Kuraray America, Inc.** for their "**Kuraray SentryGlas<sup>®</sup> Xtra<sup>™</sup> (SGX<sup>™</sup>) Clear Glass Interlayer**" dated 05/23/19, expiring on 05/23/24.
2. Notice of Acceptance No. **19-0305.02** issued to **Kuraray America, Inc.** for their "**Trosifol<sup>®</sup> Ultraclear, Clear and Color PVB Glass Interlayers**" dated 05/09/19, expiring on 07/08/24.
3. Notice of Acceptance No. **18-0301.06** issued to **Eastman Chemical Company (MA)** for their "**Saflex CP - Saflex and Saflex HP Composite Glass Interlayers with PET Core**" dated 05/17/18, expiring on 12/11/23.
4. Notice of Acceptance No. **17-0712.05** issued to **Eastman Chemical Company (MA)** for their "**Saflex Clear and Color Glass Interlayers**" dated 09/07/17, expiring on 05/21/21.

**F. STATEMENTS**

1. Statement letter of conformance, of complying with **FBC 6<sup>th</sup> Edition (2017)**, and **FBC 7<sup>th</sup> Edition (2020)**, dated May 07, 2020, issued by manufacturer, signed and sealed by Anthony Lynn Miller, P.E.
2. Statement letter of no financial interest, dated May 07, 2020, issued by manufacturer, signed and sealed by Anthony Lynn Miller, P.E.
3. Proposal No. **19-1155 TP** issued by the Product Control Section, dated January 10, 2020, signed by Ishaq Chanda, P.E.

**G. OTHERS**

1. Notice of Acceptance No. **19-0603.02**, issued to CGI Windows and Doors, Inc. for their Series "Sentinel 130" Aluminum Fixed Window - L.M.I. approved on 07/03/19 and expiring on 09/22/20.

  
Manuel Perez, P.E.  
Product Control Examiner  
NOA No. 20-0519.09  
Expiration Date: September 22, 2025  
Approval Date: October 10, 2020

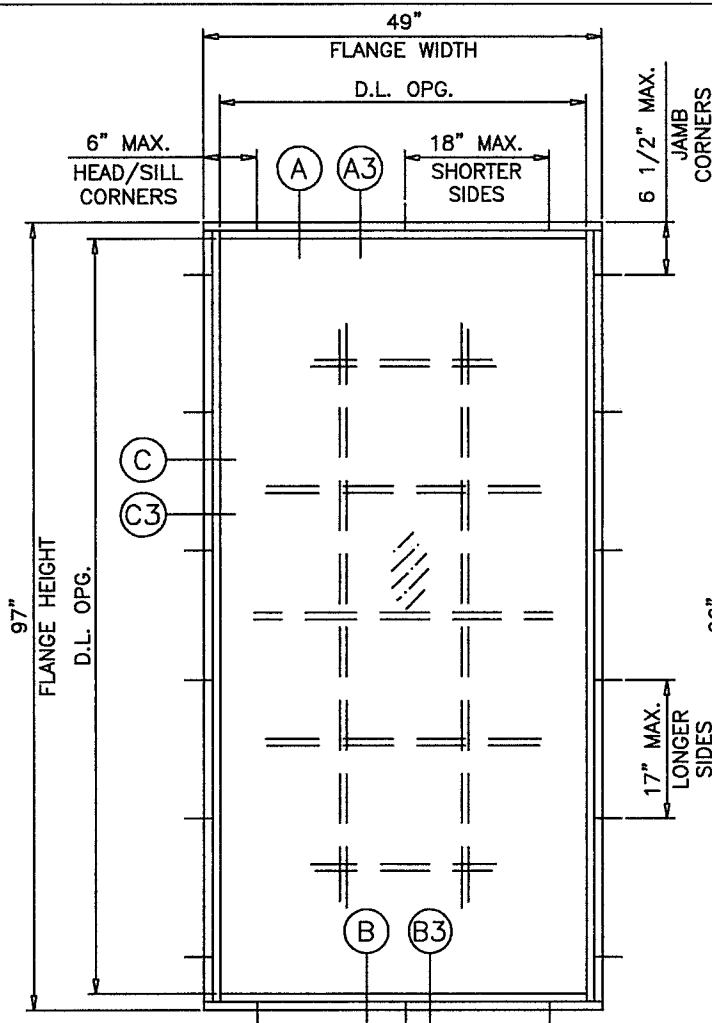

**TYP. FLANGE & FLANGE ADAPTOR FRAME**

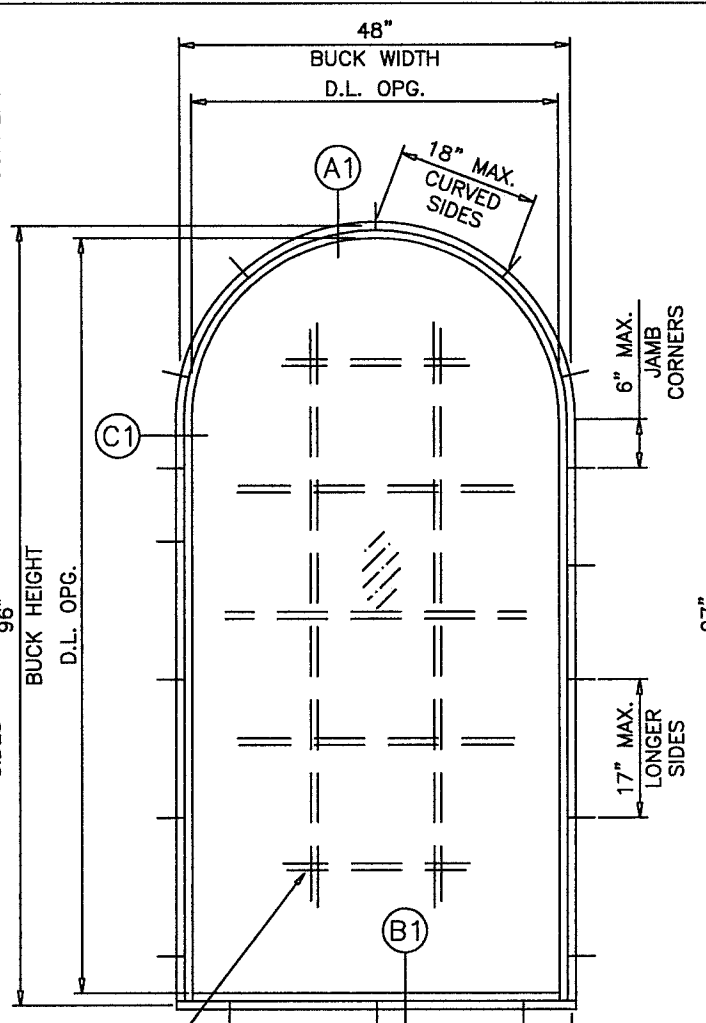

**TYP. EQUAL LEG FRAME**

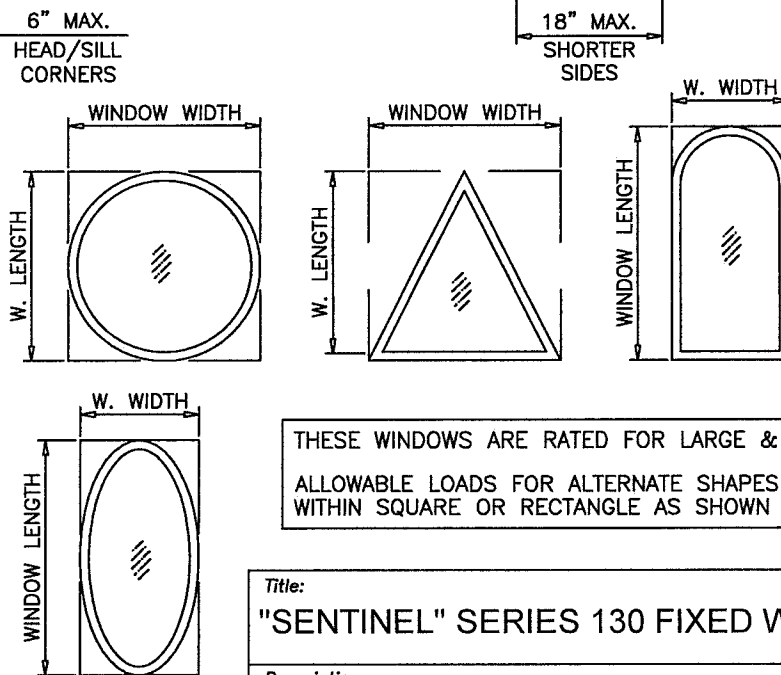
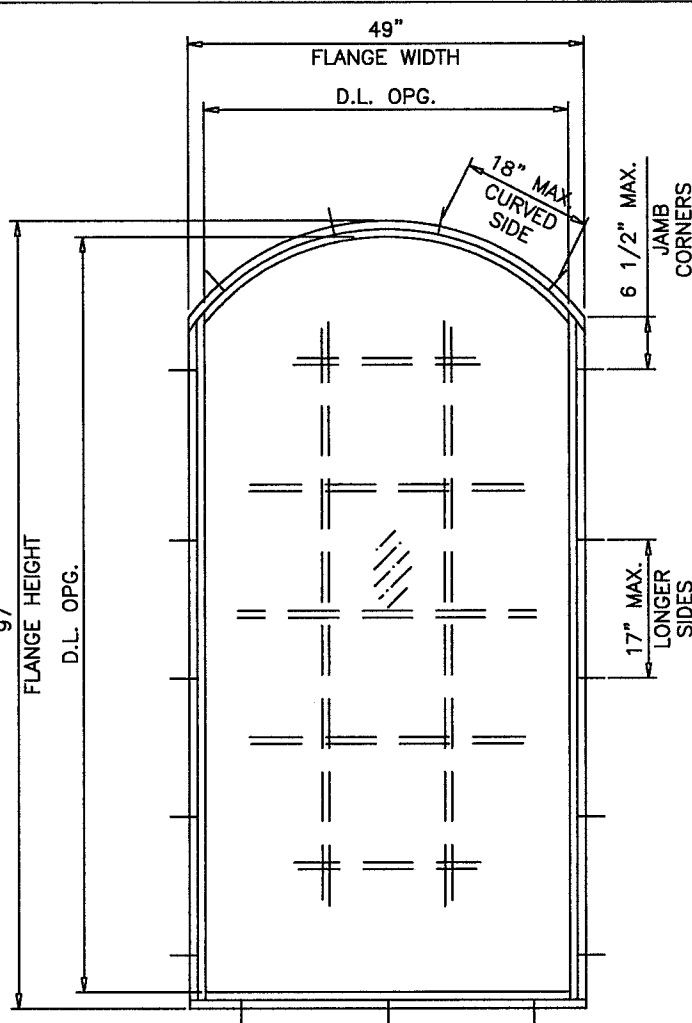

**TYPICAL ELEVATIONS**

ANCHOR SPACING SHOWN HEREIN APPLICABLE TO FLANGE AND FLUSH FRAMES. SEE SHEET 2 FOR FIN FRAMES.

LAM. GLASS
INSULATING LAM.GLASS
SMALL MISSILE IMPACT
LARGE MISSILE IMPACT

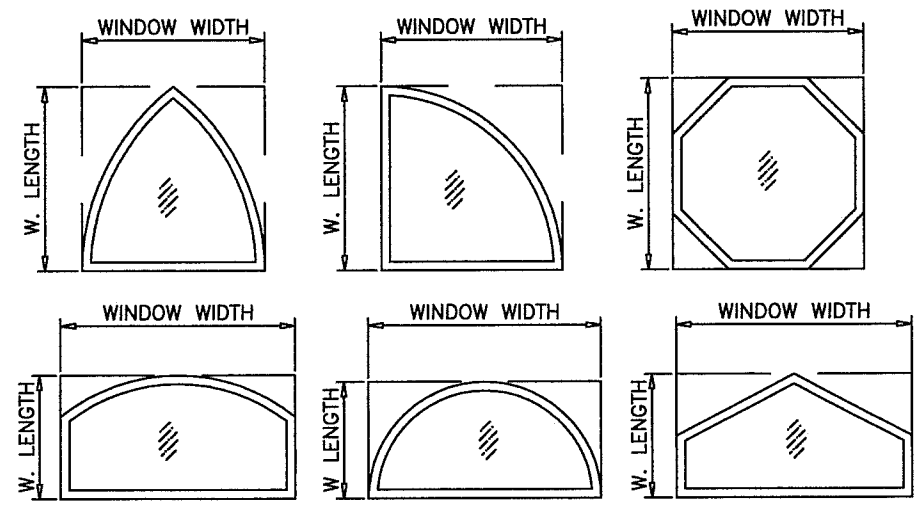
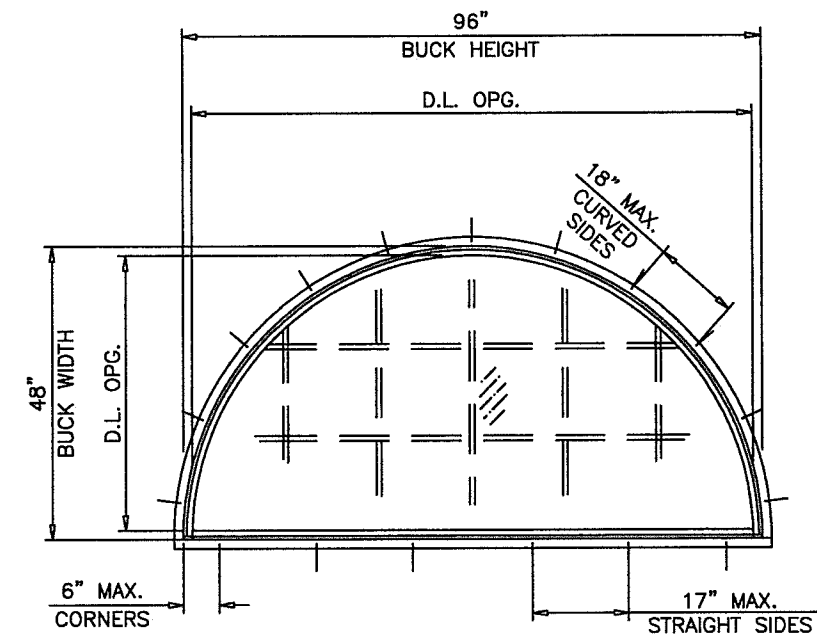

THESE WINDOWS ARE RATED FOR LARGE & SMALL MISSILE IMPACT. SHUTTERS ARE NOT REQUIRED

ALLOWABLE LOADS FOR ALTERNATE SHAPES AS SHOWN ABOVE OR SIMILAR CAN BE VERIFIED BY INSCRIBING PICTURE WINDOW SHAPE WITHIN SQUARE OR RECTANGLE AS SHOWN IN DOTTED LINES AND OBTAINING ALLOWABLE LOADS FROM THOSE SHAPES.

**SERIES 130 SENTINEL ALUMINUM FIXED WINDOW - LMI**

DESIGN LOAD RATINGS FOR THESE WINDOWS TO BE AS PER CHARTS SHOWN ON SHEET 2.

APPROVAL APPLIES TO SINGLE UNITS OR SIDE BY SIDE COMBINATIONS OF FIX./FIX. OR FIX. WDW. WITH OTHER MIAMI-DADE COUNTY APPROVED WINDOWS USING MIAMI-DADE COUNTY APPROVED MULLIONS IN BETWEEN. LOWER DESIGN PRESSURE FROM WINDOWS OR MULLION APPROVAL WILL APPLY TO ENTIRE SYSTEM.

THIS PRODUCT HAS BEEN DESIGNED AND TESTED TO COMPLY WITH THE REQUIREMENTS OF THE 2017 (6TH EDITION) & 2020 (7TH EDITION) FLORIDA BUILDING CODE INCLUDING HIGH VELOCITY HURRICANE ZONE (HVHZ).

1BY OR 2BY WOOD BUCKS & BUCK FASTENERS BY OTHERS, MUST BE DESIGNED AND INSTALLED ADEQUATELY TO TRANSFER APPLIED PRODUCT LOADS TO THE BUILDING STRUCTURE. ANCHORS SHALL BE CORROSION RESISTANT, SPACED AS SHOWN ON DETAILS AND INSTALLED PER MANUF'S INSTRUCTIONS. SPECIFIED EMBEDMENT TO BASE MATERIAL SHALL BE BEYOND WALL DRESSING OR STUCCO.

A LOAD DURATION INCREASE IS USED IN DESIGN OF ANCHORS INTO WOOD ONLY. ALL SHIMS TO BE HIGH IMPACT, NON-METALLIC AND NON-COMPRESSIBLE.

MATERIALS INCLUDING BUT NOT LIMITED TO STEEL/METAL SCREWS, THAT COME INTO CONTACT WITH OTHER DISSIMILAR MATERIALS SHALL MEET THE REQUIREMENTS OF THE 2017/2020 FLORIDA BLDG. CODE & ADOPTED STANDARDS.

THIS PRODUCT APPROVAL IS GENERIC AND DOES NOT PROVIDE INFORMATION FOR A SITE SPECIFIC PROJECT, I.E. LIFE SAFETY OF THIS PRODUCT, ADEQUACY OF STRUCTURE RECEIVING THIS PRODUCT AND SEALING AROUND OPENING FOR WATER INFILTRATION RESISTANCE ETC. CONDITIONS NOT SHOWN IN THIS DRAWING ARE TO BE ANALYZED SEPARATELY, AND TO BE REVIEWED BY BUILDING OFFICIAL.

**PRODUCT REVISED**  
 as complying with the Florida Building Code  
 NOA-No. **20-0519.09**  
 Expiration Date: **09/22/2025**  
 By: *Manuel Perez*  
 Miami-Dade Product Control

Title: <b>"SENTINEL" SERIES 130 FIXED WINDOW - LM</b>		Drawn By: <b>AGK</b>		<p><b>Impact Resistant Windows &amp; Doors</b>  <small>WERE STRONGER™</small></p> <p>3780 W. 104th Street, Hialeah, FL 33018        Tel: 305.593.6590   Fax: 305.593.6592</p>	
Description: <b>TYPICAL ELEVATIONS</b>		Date: <b>05/22/19</b>			
Revision: <b>ANCHOR TYPES, UPDATED TO FBC 2020</b>		Rev. By: <b>JR</b>	Rev. Date: <b>05/07/20</b>	PREPARED BY LYNN MILLER 1070 TECHNOLOGY DRIVE N. VENICE, FL 34275 (941) 480-1600 REGISTRATION #29296	
Series/Model: <b>PW-130 LM</b>	Scale: <b>NTS</b>	Sheet: <b>1 OF 7</b>	Drawing No. <b>PW130LMI-NOA</b>	Rev: <b>A</b>	A. LYNN MILLER, P.E. P.E.# 58705

**TYPICAL ELEVATIONS**

ANCHOR SPACING SHOWN HEREIN  
APPLICABLE TO FIN FRAMES.

LAM. GLASS  
INSULATING LAM.GLASS  
SMALL MISSILE IMPACT  
LARGE MISSILE IMPACT

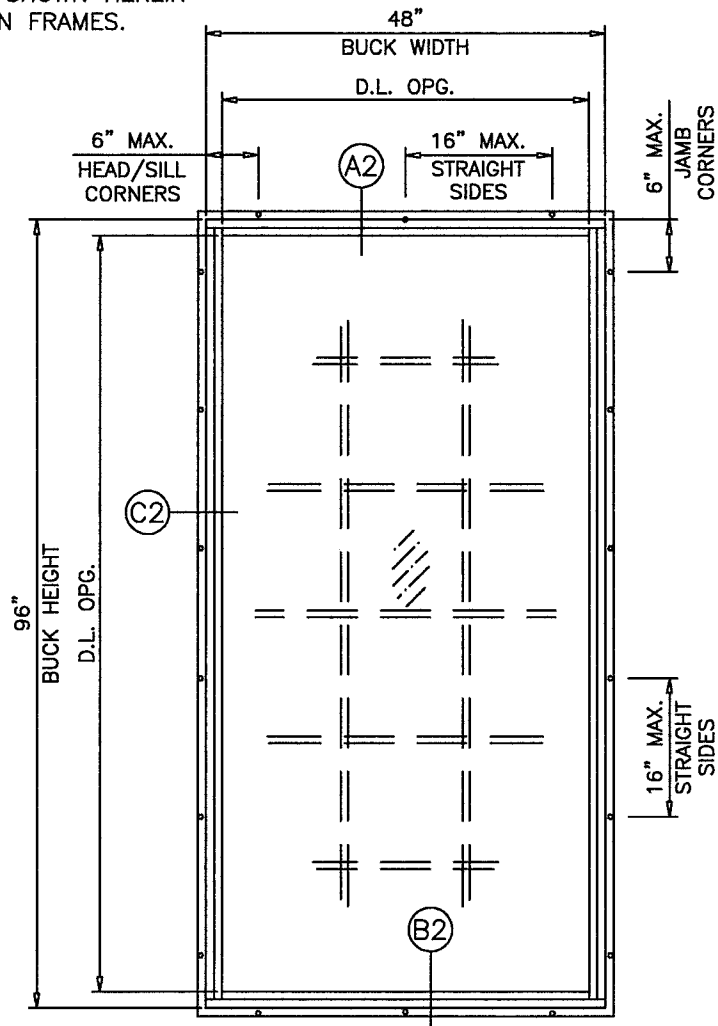

**TYP. FIN FRAME**

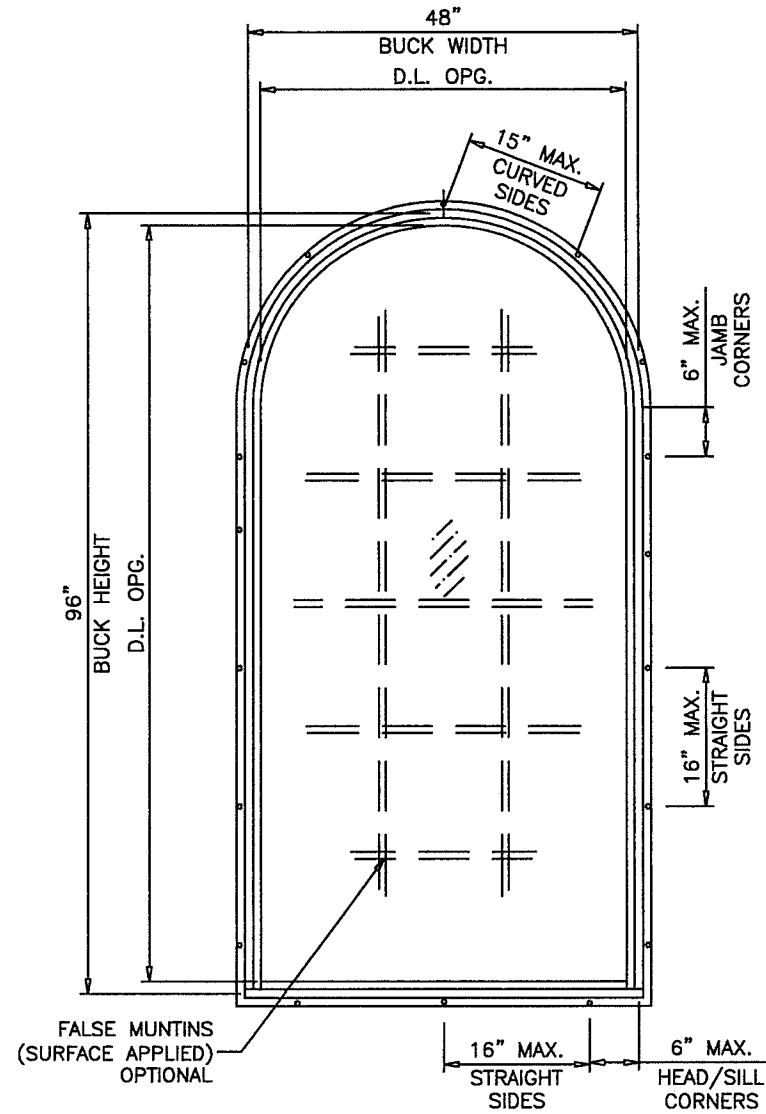

**TYP. FIN FRAME**

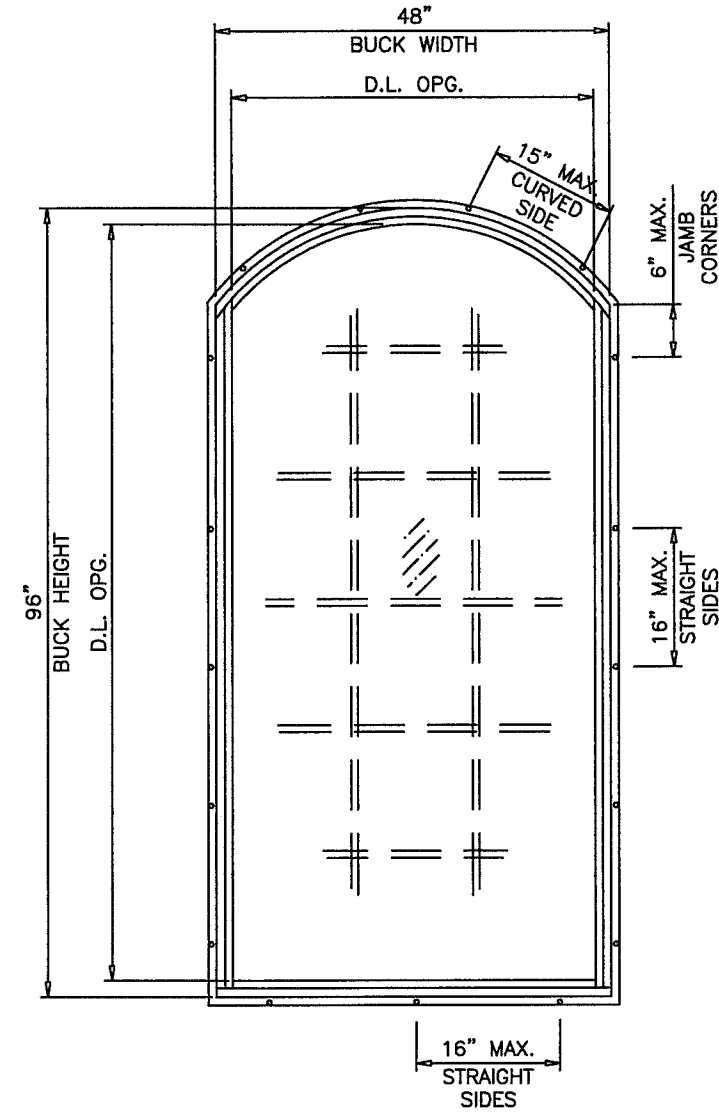

**TYP. FIN FRAME**

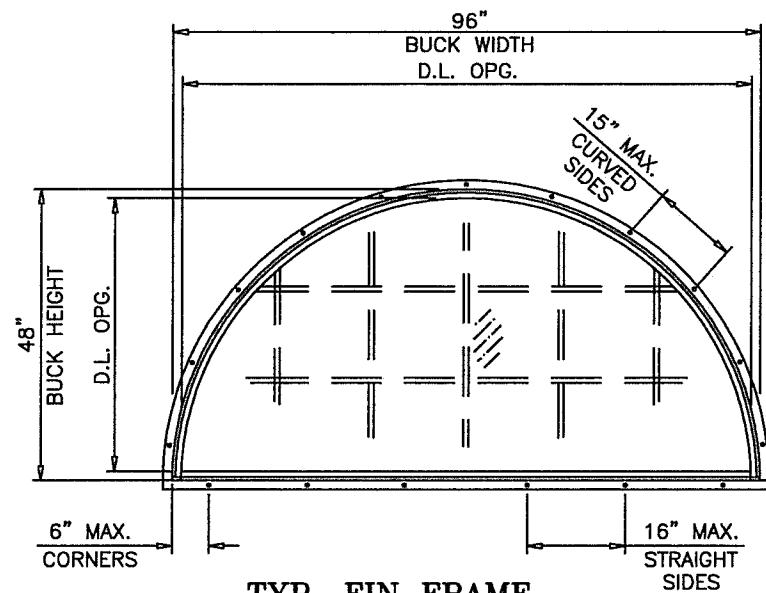

**TYP. FIN FRAME**

ALTERNATE SHAPES AS SHOWN ON SHEET 1 ALSO AVAILABLE FOR FIN FRAMES

**DAYLITE OPENINGS:**  
D.L.O. HEIGHT = BUCK HEIGHT - 3.00"  
D.L.O. WIDTH = BUCK WIDTH - 3.00"

**PRODUCT REVISED**  
as complying with the Florida  
Building Code  
NOA-No. **20-0519.09**  
Expiration Date: **09/22/2025**  
By: *Manuel Perez*  
Miami-Dade Product Control

Title: <b>"SENTINEL" SERIES 130 FIXED WINDOW - LM</b>		Drawn By: <b>AGK</b>		<p><b>Impact Resistant Windows &amp; Doors</b> WERE STRONGER™</p> <p>3780 W. 104th Street, Hialeah, FL 33018 Tel: 305.593.6590   Fax: 305.593.6592</p>	
Description: <b>TYPICAL ELEVATION CONT.</b>		Date: <b>05/22/19</b>			
Revision: <b>MINOR SHEET REFORMATTING.</b>		Rev. By: <b>JR</b>	Rev. Date: <b>05/07/20</b>	PREPARED BY LYNN MILLER 1070 TECHNOLOGY DRIVE N. VENICE, FL 34275  (941) 480-1600 REGISTRATION #29296	
Series/Model: <b>PW-130 LM</b>	Scale: <b>NTS</b>	Sheet: <b>2 OF 7</b>	Drawing No. <b>PW130LMI-NOA</b>	Rev: <b>A</b>	A. LYNN MILLER, P.E. P.E.# 58705



DESIGN LOAD CAPACITY - PSF

FLANGE DIMS.		BUCK DIMS.		GLASS TYPES 'C' & 'C1'		GLASS TYPES 'D' & 'D1'	
WIDTH (W)	LENGTH (L)	WIDTH (W)	LENGTH (L)	EXT.(+)	1NT.(-)	EXT.(+)	1NT.(-)
24"	36"	23"	35"	80.0	80.0	80.0	80.0
30"		80.0		80.0	80.0	80.0	
36"		80.0		80.0	80.0	80.0	
42"		80.0		80.0	80.0	80.0	
48"		80.0		80.0	80.0	80.0	
54"		80.0		80.0	80.0	80.0	
60"		80.0		80.0	80.0	80.0	
61"	80.0	80.0	80.0	80.0	80.0		
24"	48"	23"	47"	80.0	80.0	80.0	80.0
30"		80.0		80.0	80.0	80.0	
36"		80.0		80.0	80.0	80.0	
42"		70.2		70.2	80.0	80.0	
48"		61.3		61.3	80.0	80.0	
54"		61.3		61.3	80.0	80.0	
60"		61.3		61.3	80.0	80.0	
61"	61.3	61.3	80.0	80.0			
24"	60"	23"	59"	80.0	80.0	80.0	80.0
30"		80.0		80.0	80.0	80.0	
36"		80.0		80.0	80.0	80.0	
42"		70.2		70.2	80.0	80.0	
48"		61.3		61.3	80.0	80.0	
54"		54.3		54.3	72.5	72.5	
60"		48.8		48.8	65.1	65.1	
61"	48.8	48.8	65.1	65.1			
24"	72"	23"	71"	80.0	80.0	80.0	80.0
30"		80.0		80.0	80.0	80.0	
36"		80.0		80.0	80.0	80.0	
42"		70.2		70.2	80.0	80.0	
48"		61.3		61.3	80.0	80.0	
54"		54.3		54.3	72.5	72.5	
60"		48.8		48.8	65.1	65.1	
61"	48.0	48.0	64.0	64.0			
24"	84"	23"	83"	80.0	80.0	80.0	80.0
30"		80.0		80.0	80.0	80.0	
36"		78.2		78.2	80.0	80.0	
42"		70.0		70.0	80.0	80.0	
48"		61.3		61.3	80.0	80.0	
54"		54.3		54.3	72.5	72.5	
56"		52.4		52.4	69.8	69.8	
24"	97"	23"	96"	80.0	80.0	80.0	80.0
30"		80.0		80.0	80.0	80.0	
36"		75.6		75.6	80.0	80.0	
42"		65.2		65.2	80.0	80.0	
48"		60.6		60.6	80.0	80.0	
49"		59.6		59.6	80.0	80.0	
24"		102"		23"	101"	80.0	80.0
30"	80.0		80.0	80.0		80.0	
36"	74.6		74.6	80.0		80.0	
42"	65.7		65.7	80.0		80.0	
46"	59.3		59.3	80.0		80.0	
24"	108"	23"	107"	80.0	80.0	80.0	80.0
30"		80.0		80.0	80.0	80.0	
36"		73.8		73.8	80.0	80.0	
42"		62.4		62.4	80.0	80.0	
44"		59.1		59.1	80.0	80.0	

DESIGN LOAD CAPACITY - PSF

FLANGE DIMS.		BUCK DIMS.		GLASS TYPES 'C' & 'C1'		GLASS TYPES 'D' & 'D1'	
WIDTH (W)	LENGTH (L)	WIDTH (W)	LENGTH (L)	EXT.(+)	1NT.(-)	EXT.(+)	1NT.(-)
24"	114"	23"	113"	80.0	80.0	80.0	80.0
30"		80.0		80.0	80.0	80.0	
36"		73.0		73.0	80.0	80.0	
41"		61.4		61.4	80.0	80.0	
24"	120"	23"	119"	80.0	80.0	80.0	80.0
30"		80.0		80.0	80.0	80.0	
36"		72.4		72.4	80.0	80.0	
39"		65.9		65.9	80.0	80.0	
24"	121"	23"	120"	80.0	80.0	80.0	80.0
30"		80.0		80.0	80.0	80.0	
36"		72.3		72.3	80.0	80.0	
39"		65.8		65.8	80.0	80.0	

DESIGN LOAD CAPACITY - PSF

FLANGE DIMS.		BUCK DIMS.		GLASS TYPES 'C' & 'C1'		GLASS TYPES 'D' & 'D1'	
WIDTH (W)	LENGTH (L)	WIDTH (W)	LENGTH (L)	EXT.(+)	1NT.(-)	EXT.(+)	1NT.(-)
19-1/8"	26"	18-1/8"	25"	80.0	80.0	80.0	80.0
26-1/2"		80.0		80.0	80.0	80.0	
37"		36"		80.0	80.0	80.0	80.0
48"		47"		80.0	80.0	80.0	80.0
53-1/8"		52-1/8"		80.0	80.0	80.0	80.0
19-1/8"	38-3/8"	18-1/8"	37-3/8"	80.0	80.0	80.0	80.0
26-1/2"		80.0		80.0	80.0	80.0	
37"		36"		80.0	80.0	80.0	80.0
48"		47"		77.1	77.1	80.0	80.0
53-1/8"		52-1/8"		77.1	77.1	80.0	80.0
19-1/8"	50-5/8"	18-1/8"	49-5/8"	80.0	80.0	80.0	80.0
26-1/2"		80.0		80.0	80.0	80.0	
37"		36"		80.0	80.0	80.0	80.0
48"		47"		61.3	61.3	80.0	80.0
53-1/8"		52-1/8"		58.0	58.0	77.4	77.4
61"		60"		58.0	58.0	77.4	77.4
75-1/4"		74-1/4"		58.0	58.0	77.4	77.4
93-3/4"	92-3/4"	58.0	58.0	76.5	76.5		
19-1/8"	63"	18-1/8"	62"	80.0	80.0	80.0	80.0
26-1/2"		80.0		80.0	80.0	80.0	
37"		36"		80.0	80.0	80.0	80.0
48"		47"		61.3	61.3	80.0	80.0
53-1/8"		52-1/8"		55.3	55.3	73.7	73.7
61"	60"	48.0	48.0	64.0	64.0		
75-1/4"	74-1/4"	46.5	46.5	61.9	61.9		
19-1/8"	76"	18-1/8"	75"	80.0	80.0	80.0	80.0
26-1/2"		80.0		80.0	80.0	80.0	
37"		36"		78.9	78.9	80.0	80.0
48"		47"		61.3	61.3	80.0	80.0
53-1/8"		52-1/8"		55.3	55.3	73.7	73.7
61"	60"	48.0	48.0	64.0	64.0		

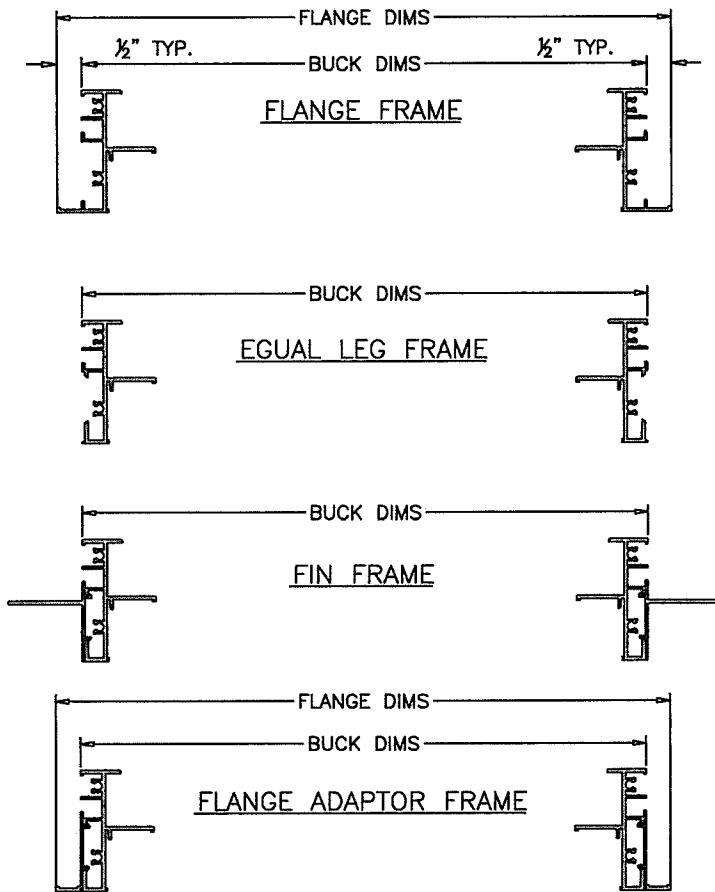

NOTE:  
GLASS CAPACITIES ON THIS SHEET ARE  
BASED ON ASTM E1300-09 (3 SEC. GUSTS)  
AND FLORIDA BUILDING COMMISSION  
DECLARATORY STATEMENT DCA05-DEC-219

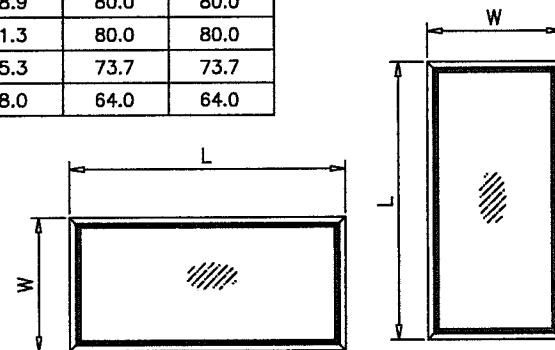

NOTE:  
WIDTH AND LENGTH DIMENSIONS CAN BE ORIENTED  
VERTICALLY OR HORIZONTALLY AS SHOWN ABOVE.

**PRODUCT REVISED**  
as complying with the Florida  
Building Code  
NOA-No. **20-0519.09**  
Expiration Date: **09/22/2025**  
By: *Manuel Perez*  
Miami-Dade Product Control

ANCHOR SPACING TO BE AS PER SHEETS 1 & 2

Title: "SENTINEL" SERIES 130 FIXED WINDOW - LM		Drawn By: AGK	
Description: DESIGN LOAD CHARTS		Date: 05/22/19	
Revision: NO CHANGES THIS SHEET.		Rev. By: JR	Rev. Date: 05/07/20
Series/Model: PW-130 LM	Scale: NTS	Sheet: 3 OF 7	Drawing No. PW130LMI-NOA
		Rev: A	



3780 W. 104th Street, Hialeah, FL 33018  
Tel: 305.593.6590 | Fax: 305.593.6592

PREPARED BY LYNN MILLER  
1070 TECHNOLOGY DRIVE  
N. VENICE, FL 34275

(941) 480-1600

REGISTRATION #29296

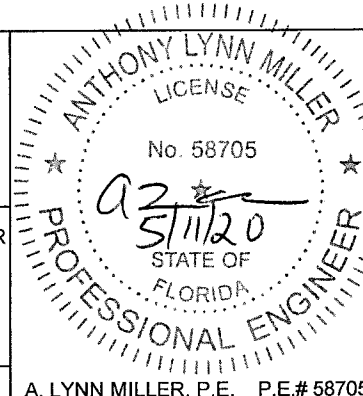

A. LYNN MILLER, P.E. P.E.# 58705

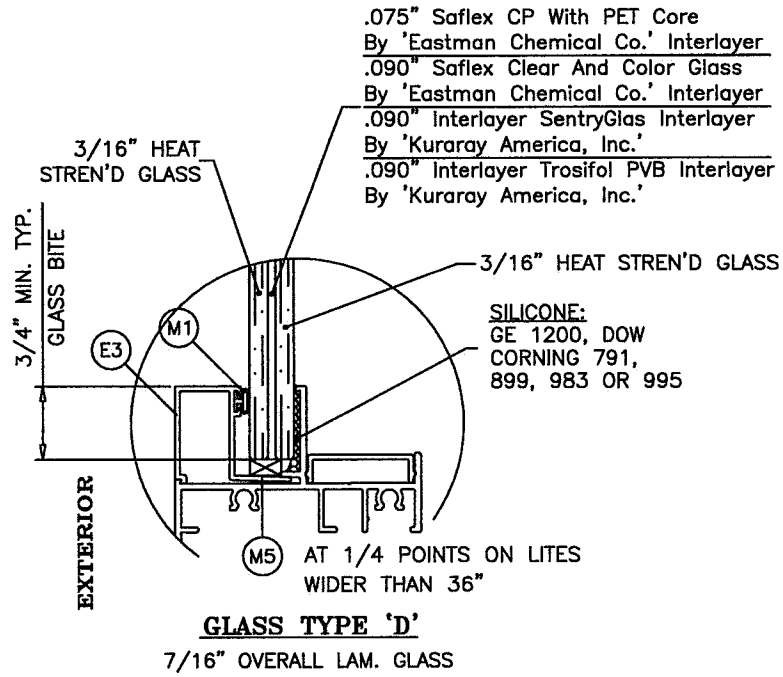
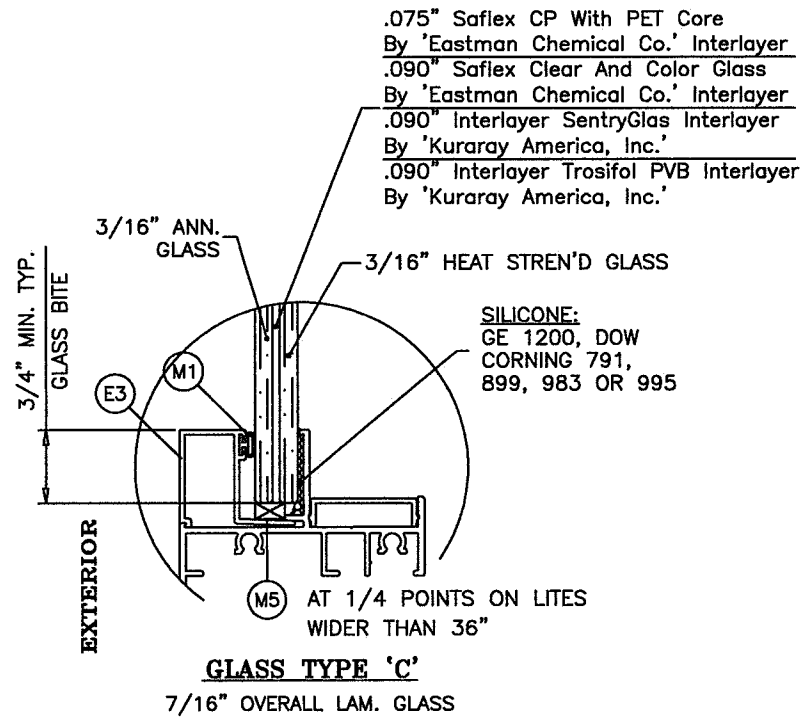

(L.M.I. & S.M.I.)

(L.M.I. ONLY)

IN ORDER TO QUALIFY FOR SMALL MISSILE IMPACT RATING  
EXTERIOR PLY OF GLASS TYPES 'C1' & 'D1' MUST BE TEMPERED.

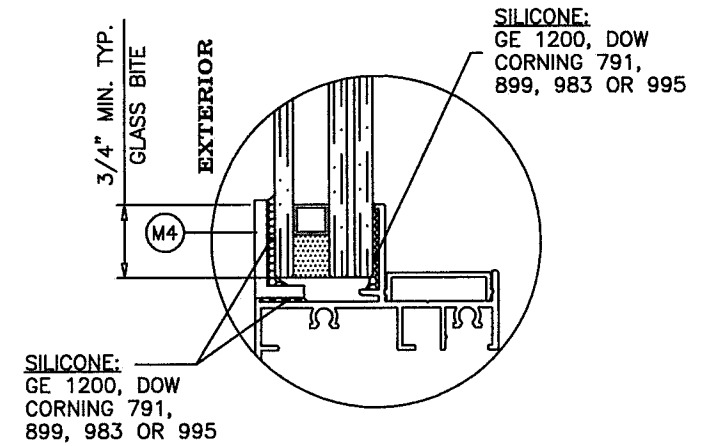

**OPTIONAL GLAZING DETAIL**  
**GLASS TYPES 'C1' & 'D1'**

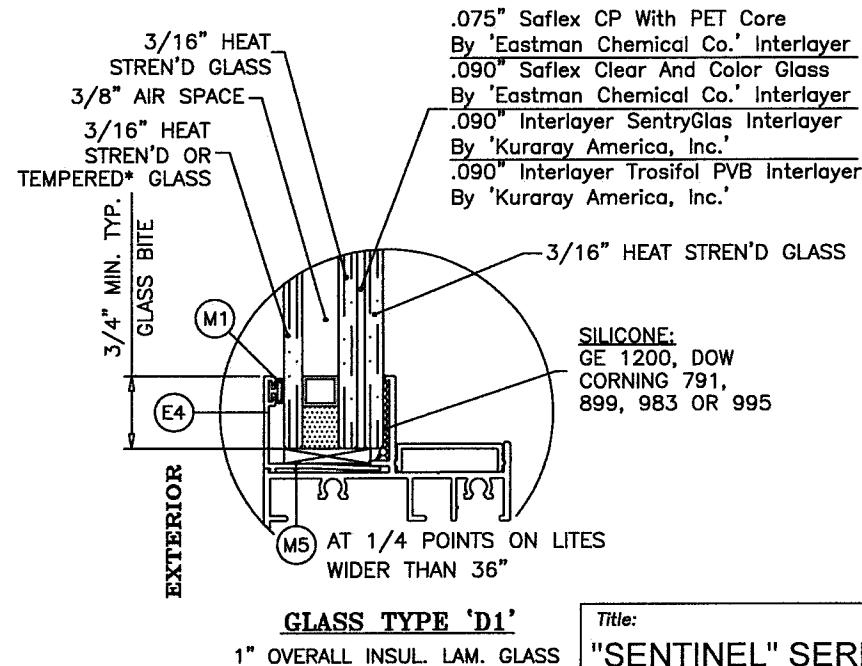
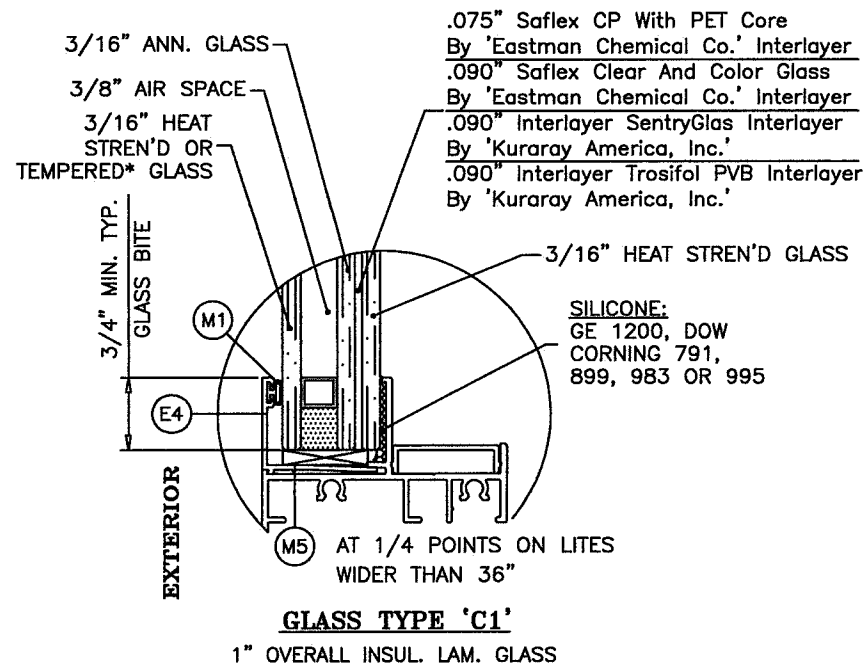

**PRODUCT REVISED**  
as complying with the Florida  
Building Code  
NOA-No. **20-0519.09**  
Expiration Date: **09/22/2025**  
By: *Manuel Fern*  
Miami-Dade Product Control

Title: <b>"SENTINEL" SERIES 130 FIXED WINDOW - LM</b>		Drawn By: <b>AGK</b>	
Description: <b>GLAZING DETAILS</b>		Date: <b>05/22/19</b>	
Revision: <b>MINOR SHEET REFORMATTING.</b>		Rev. By: <b>JR</b>	Rev. Date: <b>05/07/20</b>
Series/Model: <b>PW-130 LM</b>	Scale: <b>NTS</b>	Sheet: <b>4 OF 7</b>	Drawing No. <b>PW130LMI-NOA</b>
			Rev: <b>A</b>

**Impact Resistant Windows & Doors**  
**WERE STRONGER™**

3780 W. 104th Street, Hialeah, FL 33018  
Tel: 305.593.6590 | Fax: 305.593.6592

PREPARED BY LYNN MILLER  
1070 TECHNOLOGY DRIVE  
N. VENICE, FL 34275  
(941) 480-1600  
REGISTRATION #29296

ANTHONY LYNN MILLER  
LICENSE  
No. 58705  
5/11/20  
STATE OF FLORIDA  
PROFESSIONAL ENGINEER  
A. LYNN MILLER, P.E. P.E.# 58705

\* FOR INSULATED GLASS INSTALLATIONS ABOVE 30' IN THE HVHZ, OR FOR SAFETY GLAZING APPLICATIONS PER THE FBC, THE OUTBOARD LITE (CAP) MUST BE TEMPERED.

**TYPICAL INSTALLATION DETAILS**  
**THESE DETAILS ARE TYPICAL ON ALL FOUR SIDES OF WINDOW**

**TYPICAL ANCHORS: SEE ELEV. FOR SPACING**  
**(FLANGE & EQUAL LEG FRAMES)**

1/4" DIA. KWIK-CON II BY 'HILTI' (Fu=163 KSI, Fy=157 KSI)  
 1/4" DIA. ULTRACON BY 'ELCO/DEWALT' (Fu=177 KSI, Fy=155 KSI)  
 INTO 2BY WOOD BUCKS OR WOOD STRUCTURES  
 1-1/2" MIN. PENETRATION INTO WOOD  
 THRU 1BY BUCKS INTO CONCRETE OR BLOCKS  
 1-1/4" MIN. EMBED INTO CONCRETE (HEADS/SILL/JAMBS)  
 1-1/4" MIN. EMBED INTO BLOCKS (JAMBS)  
 DIRECTLY INTO CONCRETE OR BLOCKS  
 1-1/4" MIN. EMBED INTO CONCRETE (HEADS/SILL/JAMBS)  
 1-1/4" MIN. EMBED INTO BLOCKS (JAMBS)

**TYPICAL EDGE DISTANCE**

INTO CONCRETE AND MASONRY = 2 1/2" MIN.  
 INTO WOOD STRUCTURE = 1" MIN.

1/4" DIA. ULTRACON+ BY 'DEWALT' (Fu=164 KSI, Fy=148 KSI)  
 INTO 2BY WOOD BUCKS OR WOOD STRUCTURES  
 1-3/8" MIN. PENETRATION INTO WOOD  
 THRU 1BY BUCKS INTO CONCRETE OR BLOCKS  
 1-3/8" MIN. EMBED INTO CONCRETE (HEADS/SILL/JAMBS)  
 1-1/4" MIN. EMBED INTO HOLLOW BLOCKS (JAMBS)  
 1-3/4" MIN. EMBED INTO FILLED BLOCKS (JAMBS)

DIRECTLY INTO CONCRETE OR BLOCKS  
 1-3/8" MIN. EMBED INTO CONCRETE (HEADS/SILL/JAMBS)  
 1-1/4" MIN. EMBED INTO HOLLOW BLOCKS (JAMBS)  
 1-3/4" MIN. EMBED INTO FILLED BLOCKS (JAMBS)

**TYPICAL EDGE DISTANCE**

INTO CONCRETE AND MASONRY = 1 9/16" MIN.  
 INTO WOOD STRUCTURE = 1" MIN.

#14 SMS OR SELF DRILLING SCREWS (GRADE 2 CRS)  
 INTO MIAMI-DADE APPROVED MULLIONS OR  
 INTO METAL STRUCTURES (HEAD/SILL/JAMBS)  
 (3) THREADS MIN. PENETRATION BEYOND SUBSTRATE  
 ALUMINUM: 1/8" THK. MIN. (6063-T5 MIN.)  
 STEEL: 1/8" THK. MIN. (Fy = 35 KSI MIN.)  
 (STEEL IN CONTACT WITH ALUMINUM TO BE PLATED  
 OR PAINTED)

**TYPICAL EDGE DISTANCE**

INTO METAL STRUCTURE = 3/4" MIN.

WOOD AT HEAD, SILL OR JAMBS SG = 0.55 MIN  
 CONCRETE AT HEAD, SILL OR JAMBS f'c = 3000 PSI MIN.  
 C-90 HOLLOW/FILLED BLOCK AT JAMBS f'm = 2000 PSI MIN.

INSTALLATION DETAILS THRU 1X  
 WOOD BUCKS INTO CONCRETE

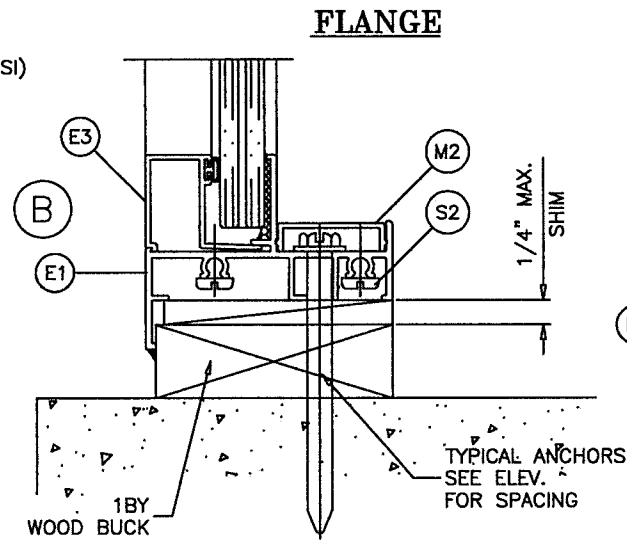

INSTALLATION DETAILS THRU 2X  
 BUCKS OR INTO WOOD STRUCTURES

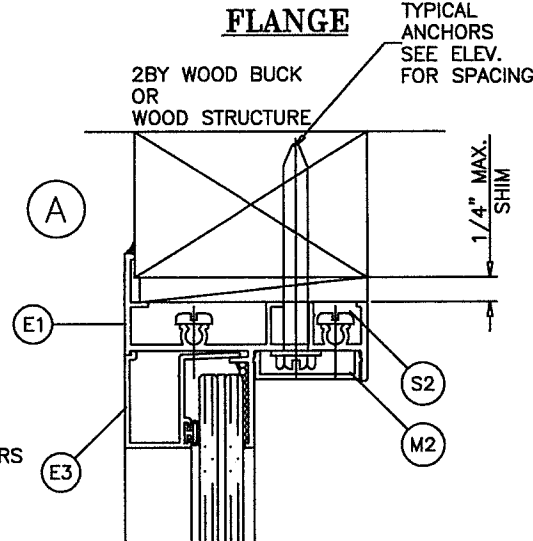

INSTALLATION DETAILS  
 DIRECTLY INTO CONCRETE

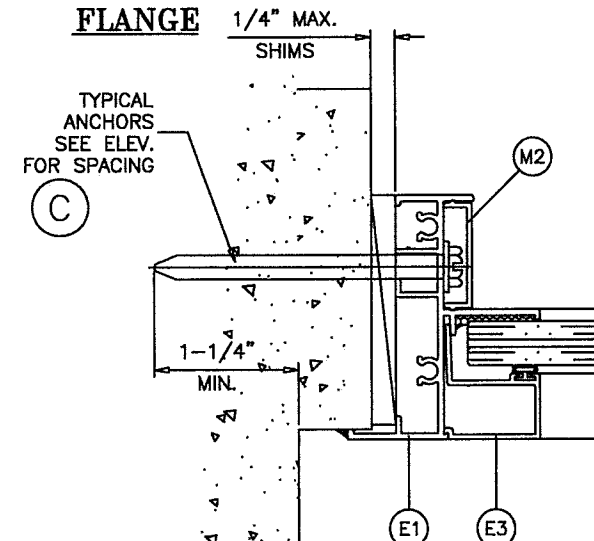

INSTALLATION DETAILS INTO METAL  
 STRUCTURES OR INTO APPROVED MULLIONS

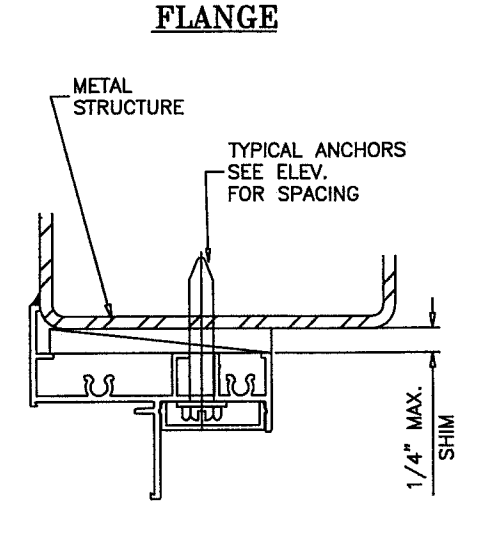

**EQUAL LEG**

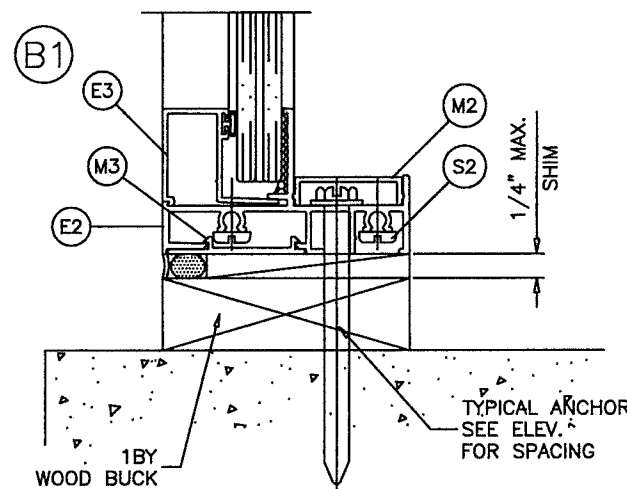

**EQUAL LEG**

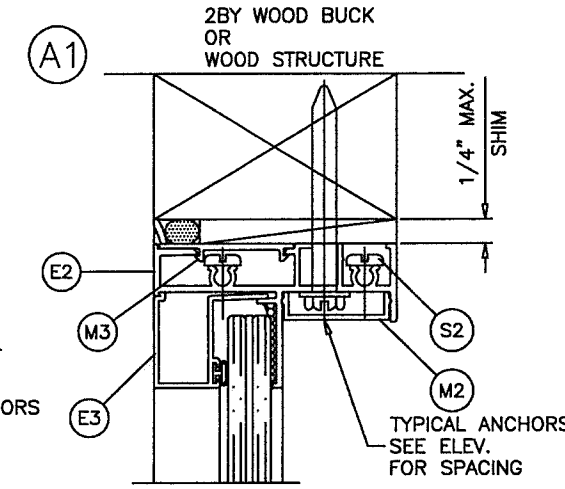

**EQUAL LEG**

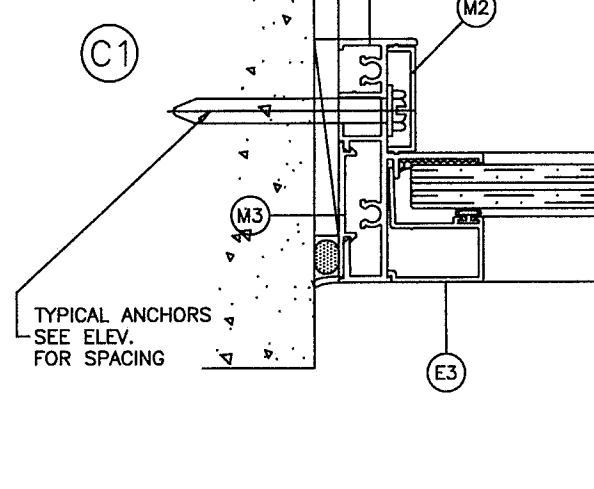

**EQUAL LEG**

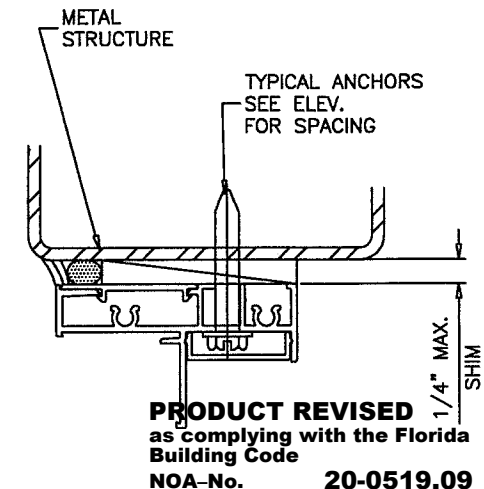

WOOD BUCKS AND METAL STRUCTURE NOT BY CGI WDW. MUST SUSTAIN LOADS IMPOSED  
 BY GLAZING SYSTEM AND TRANSFER THEM TO THE BUILDING STRUCTURE.

**TYPICAL ANCHORS: SEE ELEV. FOR SPACING**  
**FIN FRAME**

#8 SMS (GRADE 2 CRS)  
 INTO 2BY WOOD BUCKS OR WOOD STRUCTURES  
 1-1/4" MIN. PENETRATION INTO WOOD

**TYPICAL EDGE DISTANCE**  
 INTO WOOD STRUCTURE = 1" MIN.

Title: "SENTINEL" SERIES 130 FIXED WINDOW - LM		Drawn By: AGK	 3780 W. 104th Street, Hialeah, FL 33018 Tel: 305.593.6590   Fax: 305.593.6592	
Description: TYPICAL INSTALLATION DETAILS		Date: 05/22/19		
Revision: REFORMATED & ADDED ANCHOR TYPE	Rev. By: JR	Rev. Date: 05/07/20	PREPARED BY LYNN MILLER 1070 TECHNOLOGY DRIVE N. VENICE, FL 34275 (941) 480-1600 REGISTRATION #29296	A. LYNN MILLER, P.E. P.E.# 58705
Series/Model: PW-130 LM	Scale: NTS	Sheet: 5 OF 7	Drawing No. PW130LMI-NOA	

**PRODUCT REVISED**  
 as complying with the Florida  
 Building Code  
 NOA-No. 20-0519.09  
 Expiration Date: 09/22/2025

By: *Manuel Fern*  
 Miami-Dade Product Control

**TYPICAL INSTALLATION DETAILS**  
**THESE DETAILS ARE TYPICAL ON ALL FOUR SIDES OF WINDOW**

INSTALLATION DETAILS THRU 1X  
 WOOD BUCKS INTO CONCRETE

**FLANGE ADAPTOR**

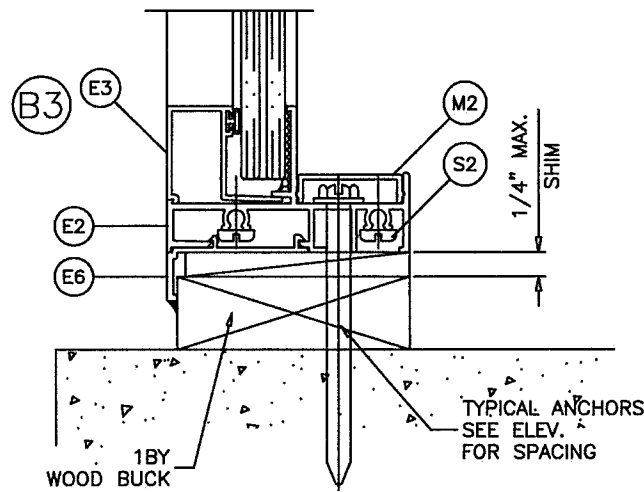

INSTALLATION DETAILS THRU 2X  
 BUCKS OR INTO WOOD STRUCTURES

**FLANGE ADAPTOR**

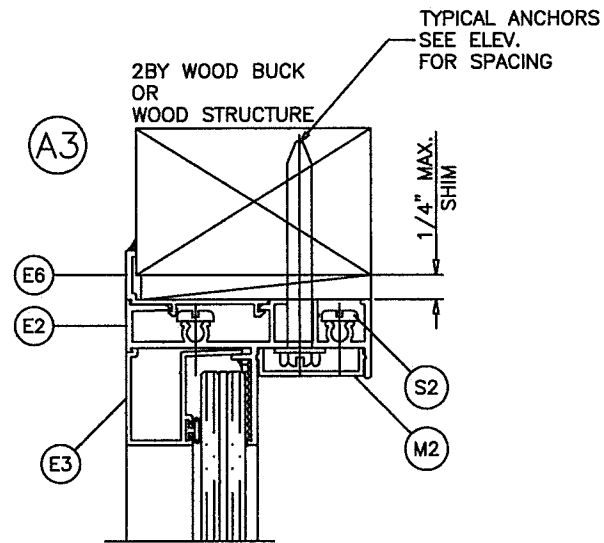

INSTALLATION DETAILS  
 DIRECTLY INTO CONCRETE

**FLANGE ADAPTOR**

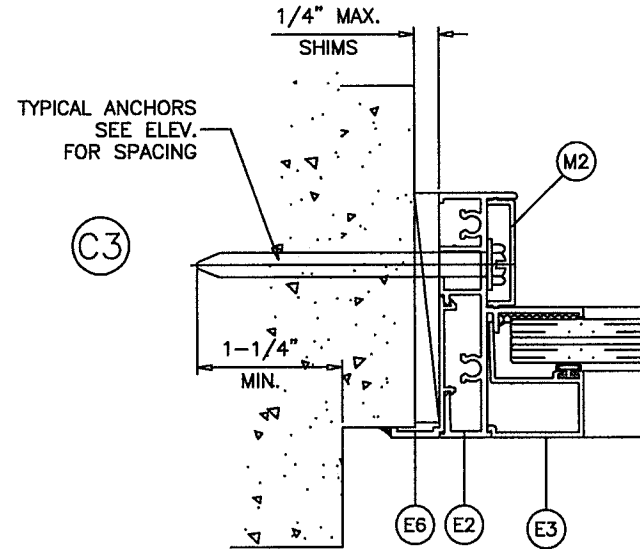

INSTALLATION DETAILS INTO METAL  
 STRUCTURES OR INTO APPROVED MULLIONS

**FLANGE ADAPTOR**

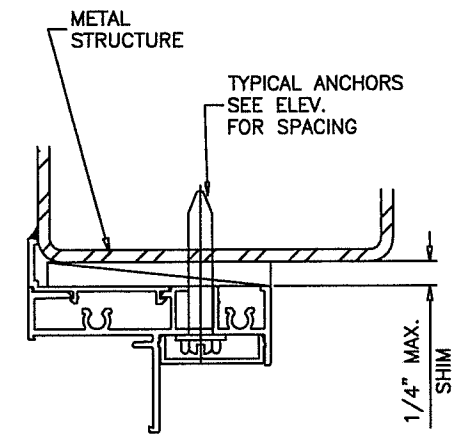

**EQUAL LEG**

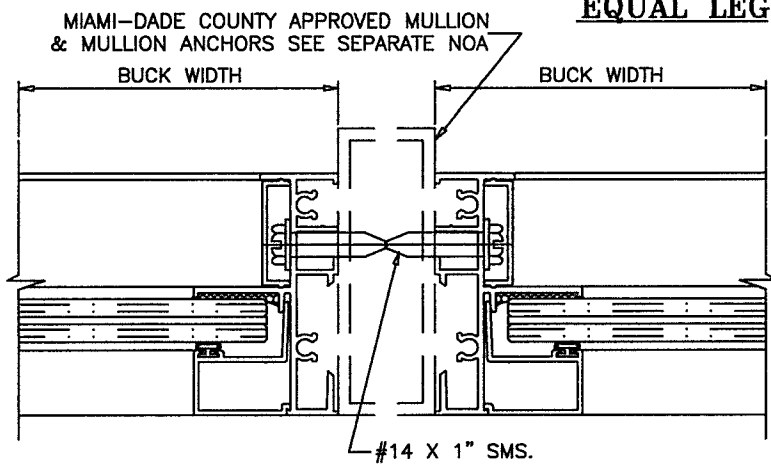

INSTALLATION DETAILS THRU FIN  
 INTO WOOD STRUCTURES

**FIN FRAME**

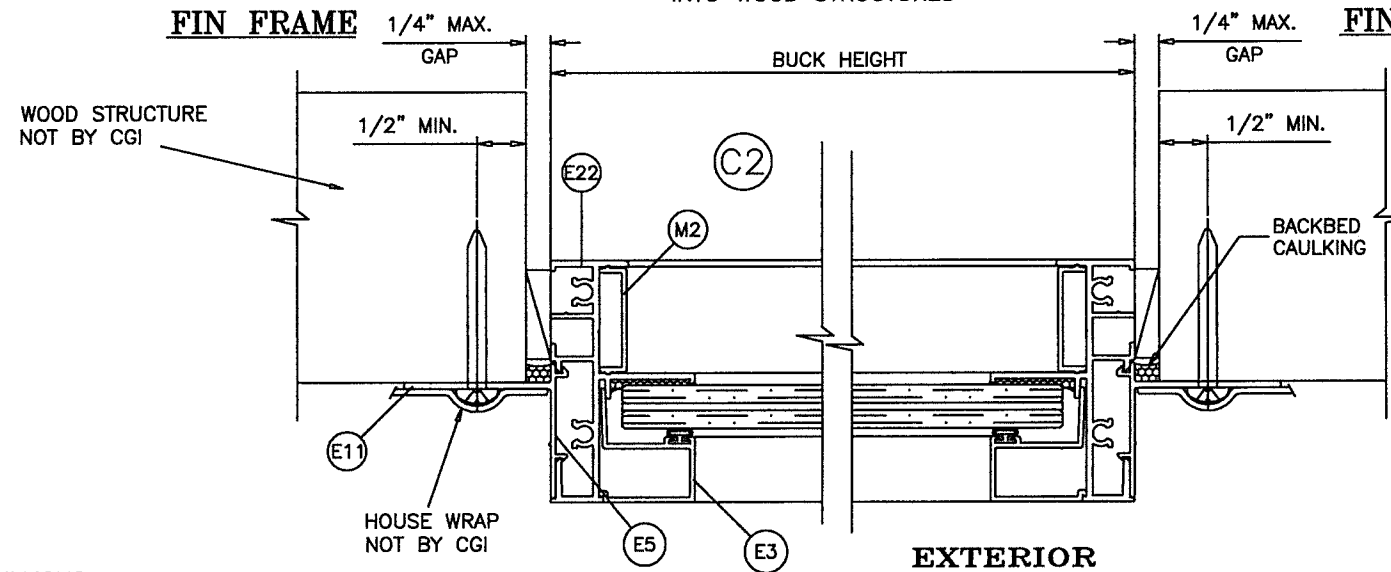

**FIN FRAME**

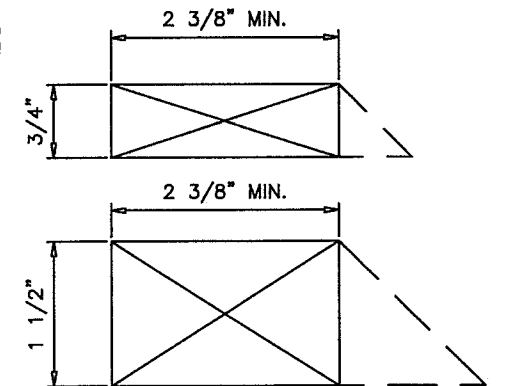

WHEN USED THE MIN. WOOD BUCK  
 DEPTH SHALL BE 2 3/8". THE USE OF  
 DEEPER OR BEVELED WOODBUCKS IS  
 PERMITTED.

INSTALLATION DETAILS INTO METAL  
 STRUCTURES OR INTO APPROVED MULLIONS

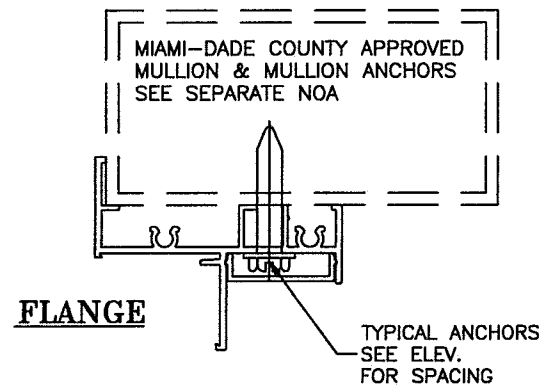

**PRODUCT REVISED**  
 as complying with the Florida  
 Building Code  
**NOA-No. 20-0519.09**  
 Expiration Date: **09/22/2025**  
 By: *Manuel Perez*  
 Miami-Dade Product Control

Title: "SENTINEL" SERIES 130 FIXED WINDOW - LM		Drawn By: AGK		<p><b>Impact Resistant Windows &amp; Doors</b>  <b>WERE STRONGER™</b></p> <p>3780 W. 104th Street, Miralab, FL 33018          Tel: 305.593.6590   Fax: 305.593.6592</p>	
Description: TYPICAL INSTALLATION DETAILS CONT.		Date: 05/22/19			
Revision: REFORMATED & ADDED ANCHOR TYPE		Rev. By: JR		Rev. Date: 05/07/20	
Series/Model: PW-130 LM	Scale: NTS	Sheet: 6 OF 7	Drawing No. PW130LMI-NOA	Rev: A	PREPARED BY LYNN MILLER 1070 TECHNOLOGY DRIVE N. VENICE, FL 34275 (941) 480-1600 REGISTRATION #29296 A. LYNN MILLER, P.E. P.E.# 58705

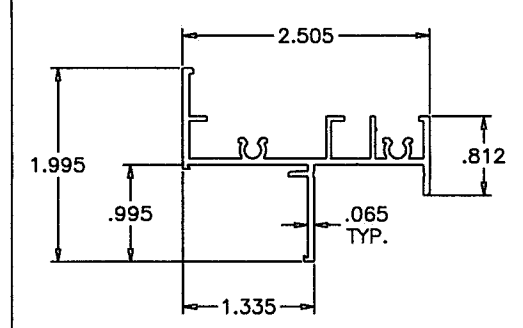

(E1) FLANGE FRAME

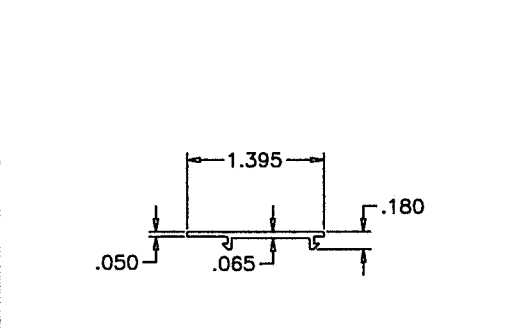

(M3) FLUSH FRAME COVER

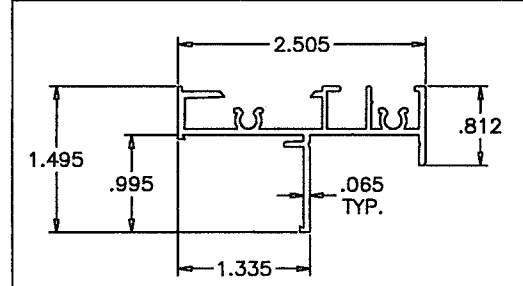

(E2) FLUSH FRAME/FIN FRAME

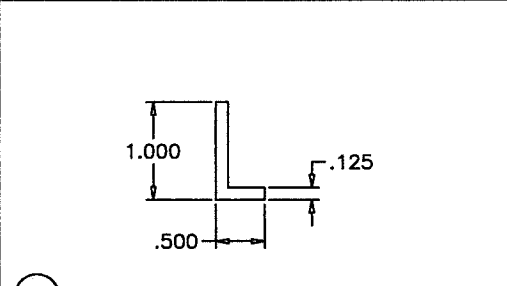

(M4) GLAZING ANGLE (LAM. INSUL. GLASS)

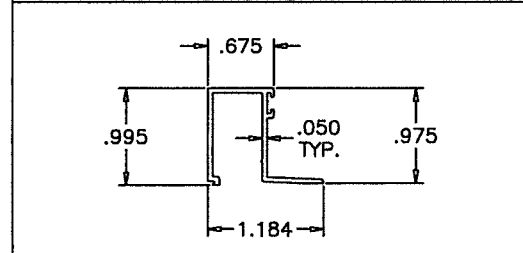

(E3) GLAZING BEAD (LAM. GLASS)

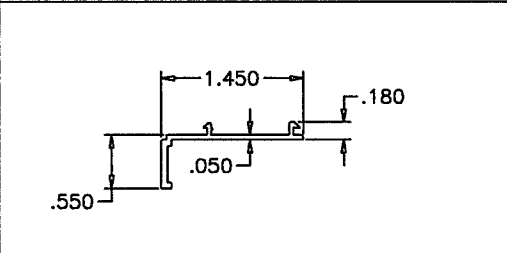

(E6) FLANGE ADAPTOR

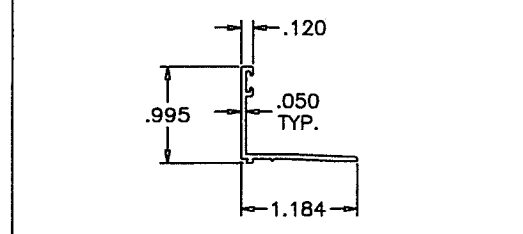

(E4) GLAZING BEAD (LAM. INSUL. GLASS)

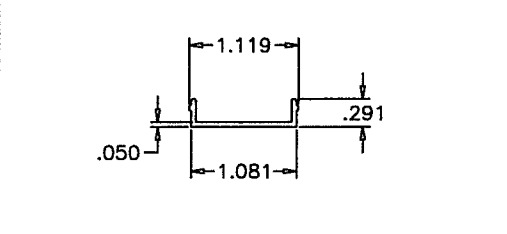

(M2) SCREW COVER

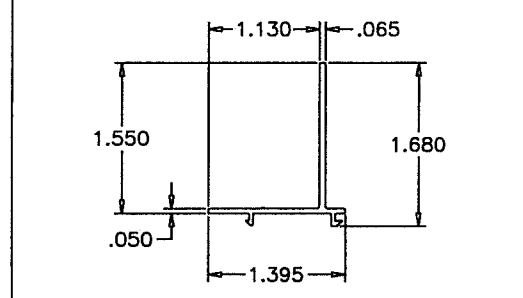

(E5) NAIL FIN ADAPTER

ITEM	PART #	QUANTITY	DESCRIPTION	MATERIAL	MANF./SUPPLIER/REMARKS
E1	CGI-118	4/ WDW.	FLANGE FRAME	6063-T6	-
E2	CGI-119	4/ WDW.	FLUSH FRAME/FIN FRAME	6063-T6	-
E3	CGI-121	4/ WDW.	GLAZING BEAD (LAM. GLASS)	6063-T6	-
E4	CGI-123	4/ WDW.	GLAZING BEAD (LAM. INSUL. GLASS)	6063-T6	-
E5	CGI-110	4/ WDW.	NAIL FIN ADAPTOR	6063-T6	-
E6	CGI-109	4/ WDW.	FRONT FLANGE ADAPTOR	6063-T6	-
M1	CGI-382V	AS REQD.	GLAZING BULB VINYL	PVC	DUROMETER 75-80 SHORE A
M2	CGI-124	AS REQD.	SCREW COVER- OPTIONAL	PVC	-
M3	CGI-112	AS REQD.	FLUSH FRAME COVER	PVC	-
M4	-	OPTIONAL	GLAZING ANGLE (1 X 1/2 X 1/8")	6063-T5	-
M5	-	2/ LITE	SETTING BLOCKS	EPDM	DUROMETER 85±5 SHORE A
S2	#10 X 1-1/4"	2/ CORNER	ASSEMBLY SCREW PHL. PH SMS	ST/ST	-

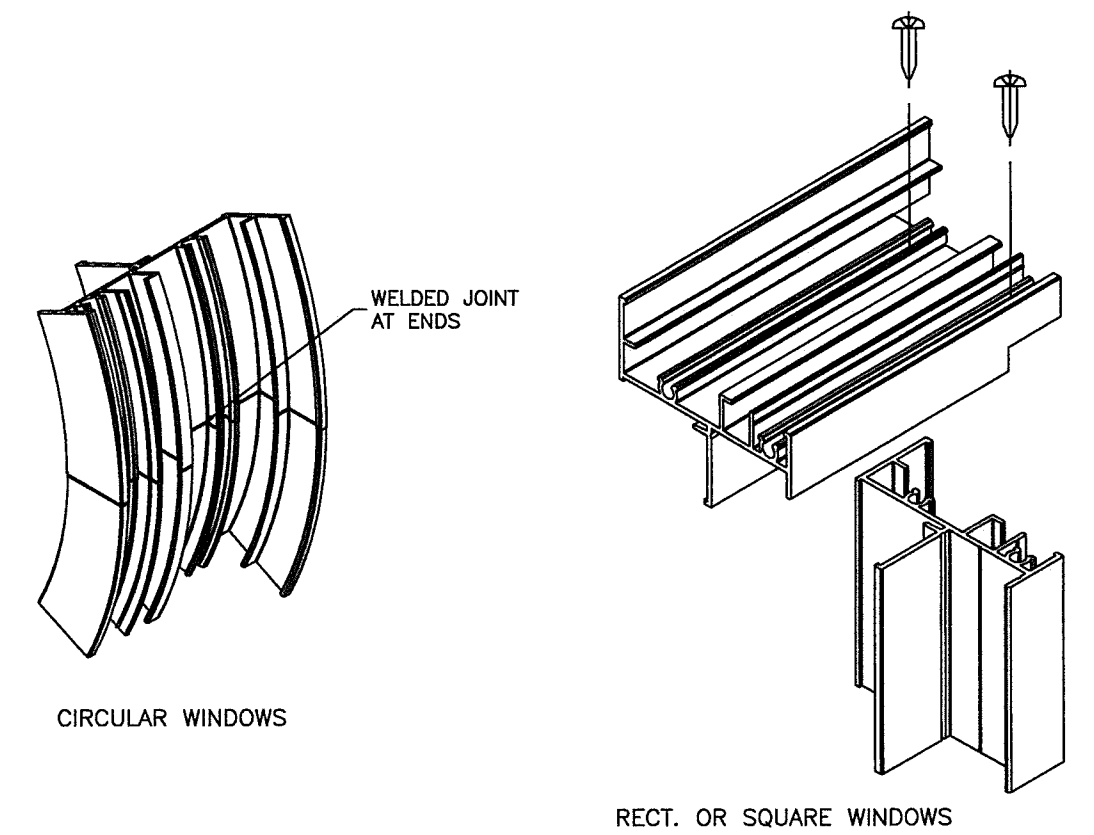

TYP. CORNER DETAILS

**PRODUCT REVISED**  
 as complying with the Florida  
 Building Code  
 NOA-No. **20-0519.09**  
 Expiration Date: **09/22/2025**  
 By: *Manuel Perez*  
 Miami-Dade Product Control

Title: "SENTINEL" SERIES 130 FIXED WINDOW - LM		Drawn By: AGK		 3780 W. 104th Street, Hialeah, FL 33018 Tel: 305.593.6590   Fax: 305.593.6592	
Description: EXTRUSIONS, BOM		Date: 05/22/19			
Revision: NO CHANGES THIS SHEET.		Rev. By: JR	Rev. Date: 05/07/20	PREPARED BY LYNN MILLER 1070 TECHNOLOGY DRIVE N. VENICE, FL 34275 (941) 480-1600 REGISTRATION #29296	A. LYNN MILLER, P.E. P.E.# 58705
Series/Model: PW-130 LM	Scale: NTS	Sheet: 7 OF 7	Drawing No. PW130LMI-NOA	Rev: A	