



MIAMI-DADE COUNTY
PRODUCT CONTROL SECTION
 11805 SW 26 Street, Room 208
 Miami, Florida 33175-2474
 T (786) 315-2590 F (786) 315-2599
www.miamidade.gov/building

DEPARTMENT OF REGULATORY AND ECONOMIC RESOURCES (RER)
 BOARD AND CODE ADMINISTRATION DIVISION

NOTICE OF ACCEPTANCE (NOA)

CGI Windows and Doors, Inc.
3780 W 104th Street
Hialeah, FL 33018

SCOPE:

This NOA is being issued under the applicable rules and regulations governing the use of construction materials. The documentation submitted has been reviewed and accepted by Miami-Dade County RER - Product Control Section to be used in Miami Dade County and other areas where allowed by the Authority Having Jurisdiction (AHJ).

This NOA shall not be valid after the expiration date stated below. The Miami-Dade County Product Control Section (In Miami Dade County) and/or the AHJ (in areas other than Miami Dade County) reserve the right to have this product or material tested for quality assurance purposes. If this product or material fails to perform in the accepted manner, the manufacturer will incur the expense of such testing and the AHJ may immediately revoke, modify, or suspend the use of such product or material within their jurisdiction. RER reserves the right to revoke this acceptance if it is determined by Miami-Dade County Product Control Section that this product or material fails to meet the requirements of the applicable building code.

This product is approved as described herein and has been designed to comply with the Florida Building Code, including the High Velocity Hurricane Zone.

DESCRIPTION: Series "Sentinel 110" Aluminum Single Hung Window – S.M.I.

APPROVAL DOCUMENT: Drawing No. SH110-SM-NOA, titled "Series 110 Alum. Single Hung Window (SM)", sheets 1 through 9 of 9, dated 07/02/20, with revision A dated 07/07/20, prepared by manufacturer, signed and sealed by Anthony Lynn Miller, P.E., bearing the Miami-Dade County Product Control Revision stamp with the Notice of Acceptance number and expiration date by the Miami-Dade County Product Control Section.

MISSILE IMPACT RATING: Small Missile Impact Resistant.

LABELING: Each unit shall bear a permanent label with the manufacturer's name or logo, city, state, model/series, and following statement: "Miami-Dade County Product Control Approved", unless otherwise noted herein.

RENEWAL of this NOA shall be considered after a renewal application has been filed and there has been no change in the applicable building code negatively affecting the performance of this product.

TERMINATION of this NOA will occur after the expiration date or if there has been a revision or change in the materials, use, and/or manufacture of the product or process. Misuse of this NOA as an endorsement of any product, for sales, advertising or any other purposes shall automatically terminate this NOA. Failure to comply with any section of this NOA shall be cause for termination and removal of NOA.

ADVERTISEMENT: The NOA number preceded by the words Miami-Dade County, Florida, and followed by the expiration date may be displayed in advertising literature. If any portion of the NOA is displayed, then it shall be done in its entirety.

INSPECTION: A copy of this entire NOA shall be provided to the user by the manufacturer or its distributors and shall be available for inspection at the job site at the request of the Building Official.

This NOA **revises NOA# 19-1015.10** and consists of this page 1 and evidence pages E-1, E-2, E-3, E-4 and E-5, as well as approval document mentioned above.

The submitted documentation was reviewed by **Manuel Perez, P.E.**



 9/1/20

NOA No. 20-0722.10
Expiration Date: November 13, 2024
Approval Date: September 10, 2020
 Page 1

NOTICE OF ACCEPTANCE: EVIDENCE SUBMITTED

1. EVIDENCE SUBMITTED UNDER PREVIOUS NOA's

A. DRAWINGS

1. Manufacturer's die drawings and sections.
(Submitted under NOA No. 14-0522.04)
2. Drawing No. **SH110SM-NOA**, titled "Series Sentinel 110 Aluminum S.H. Wdw. (SM)", sheets 1 through 9 of 9, dated 10/02/2019, prepared by A. Lynn Miller, signed and sealed by Anthony Lynn Miller, P.E.
(Submitted under NOA No.19-1015.10)

B. TESTS

1. Test reports on: 1) Uniform Static Air Pressure Test, Loading per FBC TAS 202-94
2) Large Missile Impact Test per FBC, TAS 201-94
3) Cyclic Wind Pressure Loading per FBC, TAS 203-94
along with marked-up drawings and installation diagram of a series 7500 PVC fixed window, to qualify DuPont "Butacite" PVB interlayer, Duraseal® and Super Spacer® insulating glass spacer, prepared by Certified Test Laboratories, Test Report No. **CTLA-3056 WA**, dated 03/03/15, signed and sealed by Ramesh C. Patel, P.E.
2. Test reports on: 1) Uniform Static Air Pressure Test, Loading per FBC TAS 202-94
2) Large Missile Impact Test per FBC, TAS 201-94
3) Cyclic Wind Pressure Loading per FBC, TAS 203-94
along with marked-up drawings and installation diagram of a series 7400 PVC project out window, to qualify DuPont "Butacite" PVB interlayer, Duraseal® and Super Spacer® insulating glass spacer, prepared by Certified Test Laboratories, Test Report No. **CTLA-3056 WB**, dated 03/03/15, signed and sealed by Ramesh C. Patel, P.E.
3. Test reports on: 1) Uniform Static Air Pressure Test, Loading per FBC TAS 202-94
2) Large Missile Impact Test per FBC, TAS 201-94
3) Cyclic Wind Pressure Loading per FBC, TAS 203-94
along with marked-up drawings and installation diagram of a series 238 aluminum fixed window, to qualify DuPont "Butacite" PVB interlayer, Duraseal® and Super Spacer® insulating glass spacer, prepared by Certified Test Laboratories, Test Report No. **CTLA-3056 WC**, dated 04/16/15, signed and sealed by Ramesh C. Patel, P.E.

Manuel Perez, P.E.
Product Control Examiner
NOA No. 20-0722.10
Expiration Date: November 13, 2024
Approval Date: September 10, 2020

CGI Windows and Doors, Inc.

NOTICE OF ACCEPTANCE: EVIDENCE SUBMITTED

1. EVIDENCE SUBMITTED UNDER PREVIOUS NOA's (CONTINUED)

B. TESTS (CONTINUED)

4. Test reports on: 1) Air Infiltration Test, per FBC, TAS 202-94
2) Uniform Static Air Pressure Test, Loading per FBC, TAS 202--94
3) Water Resistance Test, per FBC, TAS 202-94
4) Small Missile Impact Test per FBC, TAS 201-94
5) Cyclic Wind Pressure Loading per FBC, TAS 203-94
6) Forced Entry Test, per FBC 2411.3.2.1, and TAS 202-94
along with marked-up drawings and installation diagram of series "Sentinel 110"
aluminum single hung windows, prepared by Certified Testing Laboratories, Inc., Test
Report No. **CTLA-3009-WD**, dated 04/25/14, signed and sealed by Ramesh C. Patel,
P.E.
(Submitted under NOA No. 14-0522.04)

C. CALCULATIONS

1. Anchor verification calculations and structural analysis, complying with **FBC 6th Edition (2017)** dated 09/28/17, revised on 12/27/17, prepared by Al-Farooq Corporation, signed and sealed by Javad Ahmad, P.E.
(Submitted under NOA No.17-1011.15)
2. Glazing complies with **ASTM E1300-09**

D. QUALITY ASSURANCE

1. Miami-Dade Department of Regulatory and Economic Resources (RER).

E. MATERIAL CERTIFICATIONS

1. Notice of Acceptance No. **16-1117.01** issued to **Kuraray America, Inc.** for their "**Trosifol® Ultraclear, Clear and Color PVB Glass Interlayers**" dated 01/19/17, expiring on 07/08/19.
2. Notice of Acceptance No. **17-0712.05** issued to **Eastman Chemical Company (MA)** for their "**Saflex Clear and Color Glass Interlayers**" dated 09/07/17, expiring on 05/21/21.

Manuel Perez, P.E.
Product Control Examiner
NOA No. 20-0722.10
Expiration Date: November 13, 2024
Approval Date: September 10, 2020

CGI Windows and Doors, Inc.

NOTICE OF ACCEPTANCE: EVIDENCE SUBMITTED

1. EVIDENCE SUBMITTED UNDER PREVIOUS NOA's (CONTINUED)
F. STATEMENTS

1. Statement letter of conformance, of complying with **FBC 6th Edition (2017)** and of no financial interest, dated October 04, 2019 issued, signed and sealed by Anthony Lynn Miller, P.E.
(Submitted under NOA No. 19-1015.10)
2. Notification of Successor Engineer for CGI NOA documents dated October 04, 2019 issued, signed and sealed by Anthony Lynn Miller, P.E.
(Submitted under NOA No.19-1015.10)
3. Laboratory compliance letter for Test Report No. **HTL-0080-0101-10**, issued by Hurricane Test Laboratory, LLC, dated February 03, 2010, signed and sealed by Vinu J. Abraham, P.E.
(Submitted under NOA No.14-0522.04)
4. Test Proposal for the qualification of **Butacite®** PVB glass interlayer by DuPont as well as **Duraseal®** and **Super Spacer® Standard** warm-edge flexible insulating glass spacers, dated December 16, 2014, issued by RER, Product Control Section, signed by Jaime Gascon, Supervisor.
(Submitted under NOA No.15-0512.09)

G. OTHERS

1. Notice of Acceptance No. **17-1011.15**, issued to CGI Windows & Doors, Inc. for their Series "Sentinel 110" Aluminum Single Hung Window - S.M.I., approved on 01/11/18 and expiring on 11/13/19.

Manuel Perez, P.E.
Product Control Examiner
NOA No. 20-0722.10
Expiration Date: November 13, 2024
Approval Date: September 10, 2020

CGI Windows and Doors, Inc.

NOTICE OF ACCEPTANCE: EVIDENCE SUBMITTED

2. NEW EVIDENCE SUBMITTED

A. DRAWINGS

1. Drawing No **SH110-SM-NOA**, titled “Series 110 Alum Single Hung Window (SM)”, sheets 1 through 9 of 9, dated 07/02/20, with revision A dated 07/07/20, prepared by manufacturer, signed and sealed by Anthony Lynn Miller, P.E.

B. TESTS

1. Test reports on: 1) Air Infiltration Test, per FBC, TAS 202-94
2) Uniform Static Air Pressure Test, Loading per FBC, TAS 202-94
3) Water Resistance Test, per FBC, TAS 202-94
4) Large Missile Impact Test per FBC, TAS 201-94
5) Cyclic Wind Pressure Loading per FBC, TAS 203-94
6) Forced Entry Test, per ASTM F588 and TAS 202-94

along with marked-up drawings and installation diagram of all PGT Industries, Inc. CGI Windows and Doors, Inc., representative units listed below and tested to qualify **Dowsil 791** and **Dowsil 983** silicones, per Proposal #**19-1155TP**, prepared by Fenestration Testing Laboratory, Inc., Test Reports No.:

PGT Industries, Inc. test specimens:

FTL-7897, PGT PW5520 PVC Fixed Window (unit 6 in proposal), dated 09/03/14
FTL-20-2107.1, PGT SGD780 Aluminum Sliding Glass Door (unit 7 in proposal)
FTL-20-2107.2, PGT CA740 Alum. Outswing Casement Window (unit 8 in proposal)
FTL-20-2107.3, PGT PW7620A Aluminum Fixed Window (unit 9 in proposal) and
FTL-20-2107.4, PGT PW7620A Aluminum Fixed Window (unit 10 in proposal)
all dated 07/13/20 and signed and sealed by Idalmis Ortega, P.E.

CGI Windows and Doors Inc. test specimens:

FTL-20-2108.1, CGI SH360 Aluminum Single Hung Window (unit 1 in proposal)
FTL-20-2108.2, CGI CA238 Alum. Outswing Casement Window (unit 2 in proposal)
FTL-20-2108.3, CGI SGD560 Aluminum Sliding Glass Door (unit 3 in proposal)
FTL-20-2108.4, CGI PW410 Aluminum Fixed Window (unit 4 in proposal) and
FTL-20-2108.5, CGI SH360 Aluminum Single Hung Window (unit 5 in proposal)
all dated 08/24/20 and signed and sealed by Idalmis Ortega, P.E.

C. CALCULATIONS

1. Anchor verification calculations and structural analysis, complying with **FBC 7th Edition (2020)**, dated 07/08/20, prepared by manufacturer, signed and sealed by Anthony Lynn Miller, P.E.



Manuel Perez, P.E.
Product Control Examiner
NOA No. 20-0722.10
Expiration Date: November 13, 2024
Approval Date: September 10, 2020

CGI Windows and Doors, Inc.

NOTICE OF ACCEPTANCE: EVIDENCE SUBMITTED

2. NEW EVIDENCE SUBMITTED (CONTINUED)

D. STATEMENTS

1. Statement letter of conformance, complying with **FBC 6th Edition (2017)** and the **FBC 7th Edition (2020)**, dated July 08, 2020, issued by manufacturer, signed and sealed by Anthony Lynn Miller, P.E.
2. Statement letter of no financial interest, dated July 08, 2020, issued by manufacturer, signed and sealed by Anthony Lynn Miller, P.E.
3. Proposal No. **19-1155 TP** issued by the Product Control Section, dated January 10, 2020, signed by Ishaq Chanda, P.E.

G. OTHERS

1. Notice of Acceptance No. **19-1015.10**, issued to CGI Windows & Doors for their Series "Sentinel 110" Aluminum Single Hung Window - S.M.I., approved on 11/07/19 and expiring on 11/13/24.

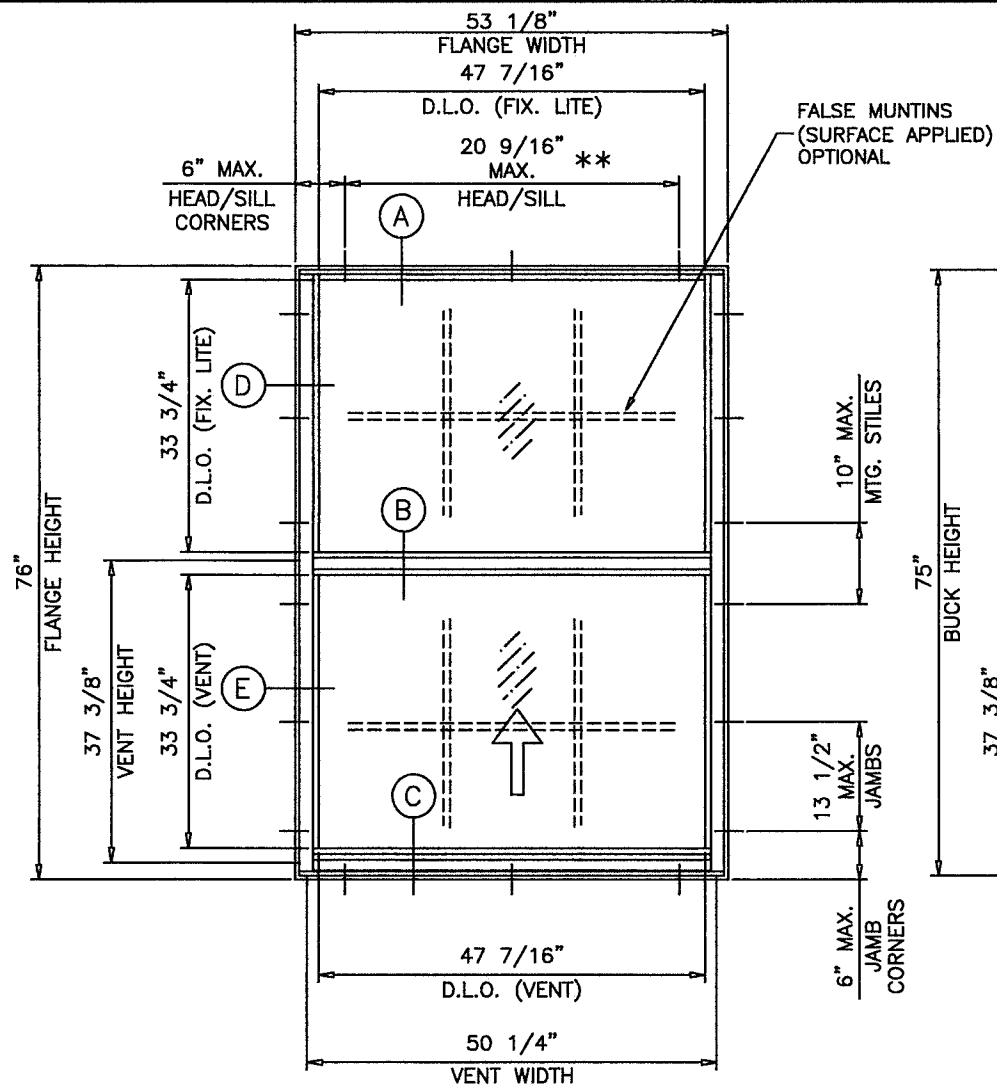

Manuel Perez, P.E.
Product Control Examiner
NOA No. 20-0722.10
Expiration Date: November 13, 2024
Approval Date: September 10, 2020

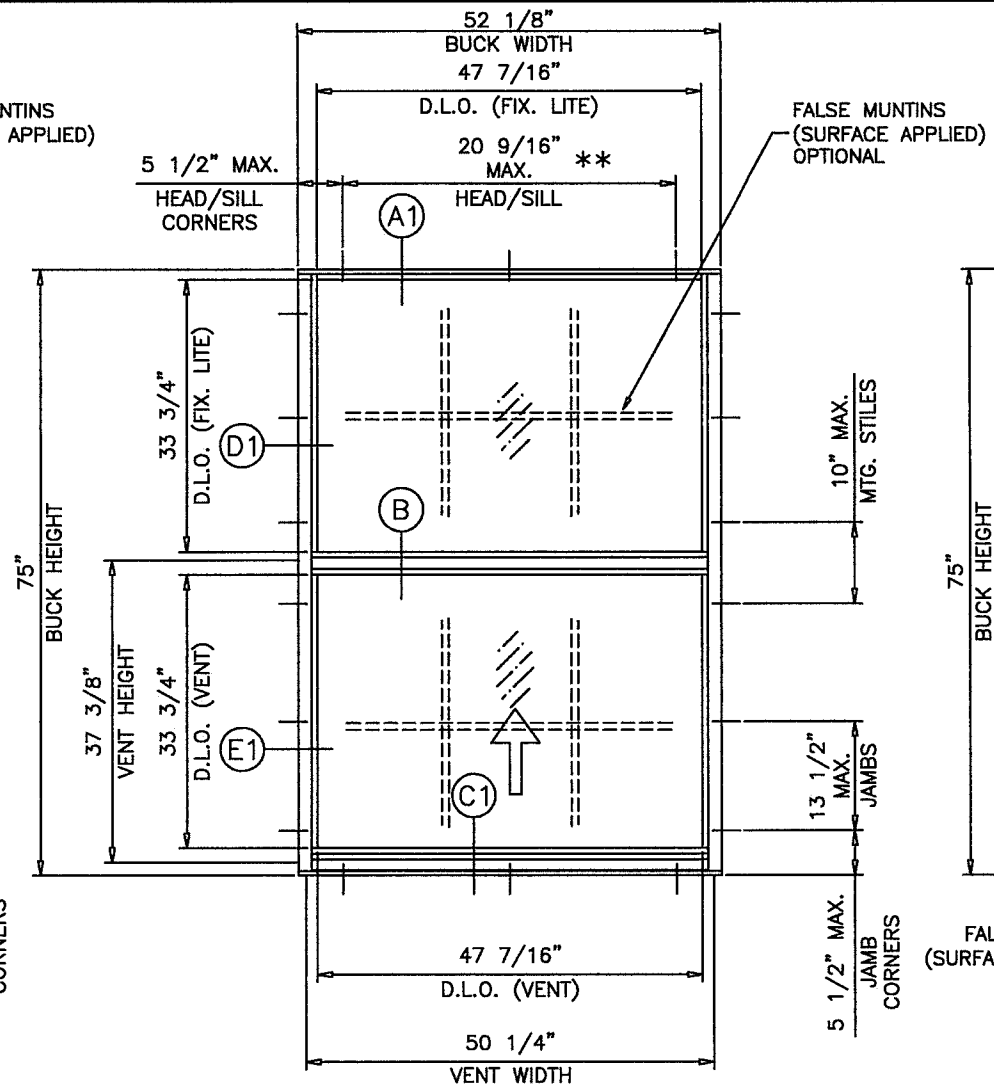

FLANGE & FLANGE ADAPTOR FRAME

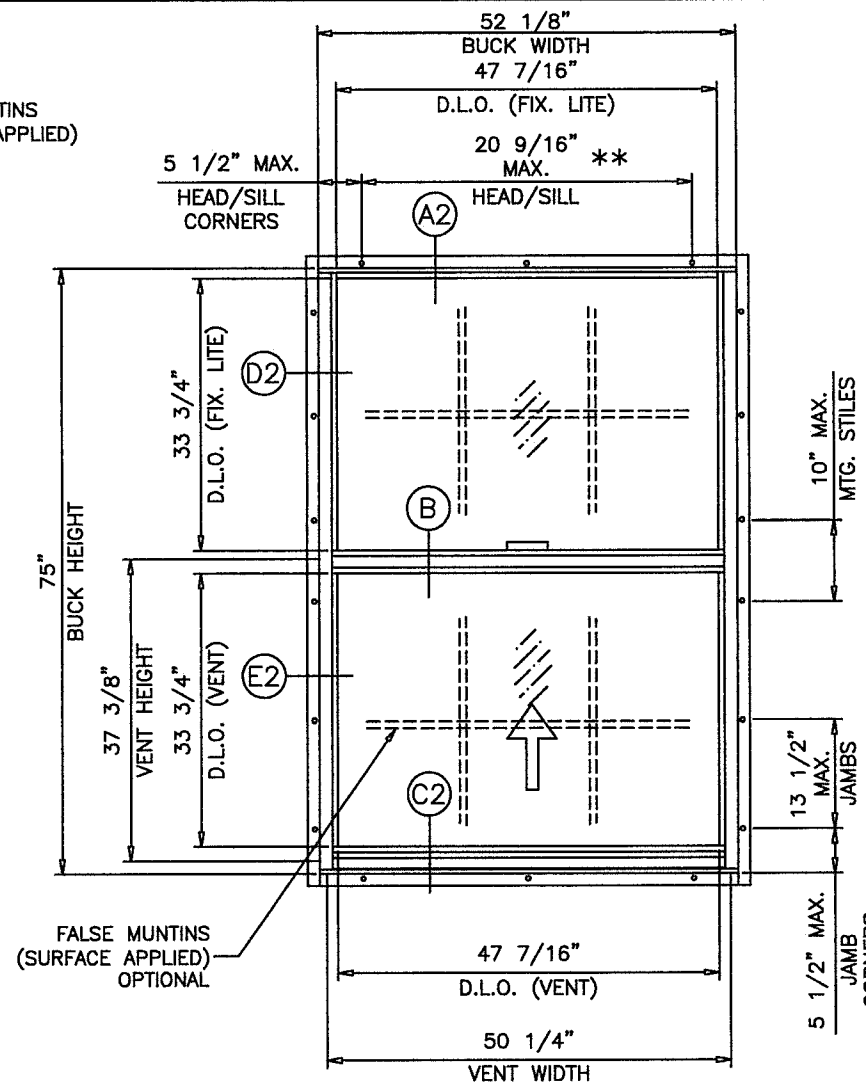

EQUAL LEG FRAME



FIN FRAME

**SERIES SENTINEL 110 ALUMINUM SINGLE HUNG WINDOW
SMALL MISSILE (SM)**

DESIGN LOAD RATINGS FOR THESE WINDOWS TO BE AS PER CHARTS SHOWN ON SHEET 2.

APPROVAL APPLIES TO SINGLE UNITS OR SIDE BY SIDE COMBINATIONS OF S.H./S.H. OR SINGLE HUNG WINDOW WITH OTHER MIAMI-DADE COUNTY APPROVED WINDOWS USING MIAMI-DADE COUNTY APPROVED MULLIONS IN BETWEEN. LOWER DESIGN PRESSURE FROM WINDOWS OR MULLION APPROVAL WILL APPLY TO ENTIRE SYSTEM.

THIS PRODUCT HAS BEEN DESIGNED AND TESTED TO COMPLY WITH THE REQUIREMENTS OF THE 2017 (6TH EDITION) AND 2020 (7TH EDITION) FLORIDA BUILDING CODE INCLUDING HIGH VELOCITY HURRICANE ZONE (HVHZ).

1BY OR 2BY WOOD BUCKS & BUCK FASTENERS BY OTHERS, MUST BE DESIGNED AND INSTALLED ADEQUATELY TO TRANSFER APPLIED PRODUCT LOADS TO THE BUILDING STRUCTURE.

ANCHORS SHALL BE CORROSION RESISTANT, SPACED AS SHOWN ON DETAILS AND INSTALLED PER MANUF'S INSTRUCTIONS. SPECIFIED EMBEDMENT TO BASED MATERIAL SHALL BE BEYOND WALL DRESSING OR STUCCO.

A LOAD DURATION INCREASE IS USED IN DESIGN OF ANCHORS INTO WOOD ONLY.

ALL SHIMS TO BE HIGH IMPACT, NON-METALLIC AND NON-COMPRESSIBLE.

MATERIALS INCLUDING BUT NOT LIMITED TO STEEL/METAL SCREWS, THAT COME INTO CONTACT WITH OTHER DISSIMILAR MATERIALS SHALL MEET THE REQUIREMENTS OF THE 2017/2020 FLORIDA BLDG. CODE & ADOPTED STANDARDS.

THIS PRODUCT APPROVAL IS GENERIC AND DOES NOT PROVIDE INFORMATION FOR A SITE SPECIFIC PROJECT, i.e. LIFE SAFETY OF THIS PRODUCT, ADEQUACY OF STRUCTURE RECEIVING THIS PRODUCT AND SEALING AROUND OPENING FOR WATER INFILTRATION RESISTANCE, ETC. CONDITIONS NOT SHOWN IN THIS DRAWING ARE TO BE ANALYZED SEPARATELY, AND TO BE REVIEWED BY BUILDING OFFICIAL.

** CENTER ANCHOR REQUIRED WHEN SPACING EXCEEDS 20 9/16"

**LAMINATED GLASS
INSULATING LAM. GLASS
SMALL MISSILE IMPACT**

THESE WINDOWS ARE RATED FOR SMALL MISSILE IMPACT. MIAMI-DADE COUNTY APPROVED IMPACT RESISTANT SHUTTERS REQUIRED FOR INSTALLATIONS UP TO 30 FT. OF GRADE. SHUTTERS NOT REQD. FOR INSTALLATIONS ABOVE 30 FT. OF GRADE.

PRODUCT REVISED
as complying with the Florida Building Code
NOA-No. **20-0722.10**
Expiration Date: **11/13/2024**
By: *Manuel Perez*
Miami-Dade Product Control

Revision: REVISED FOR 2020 FBC, ADDED ANCHOR TYPE, BACKBEDDING & REFORMATTED - JR - 07/07/20

PREPARED BY A. LYNN MILLER 1070 TECHNOLOGY DRIVE N. VENICE, FL 34275 (941) 480-1600 REGISTRATION #29296	Date	07/02/20	JENS ROSOWSKI Drawn By	Rev.	A
	SERIES 110 ALUM. SINGLE HUNG WINDOW (SM)	Title		SH110-SM-NOA	DMC No.
Impact Resistant Windows & Doors WERE STRONGER™ CGI WINDOWS AND DOORS, INC. 3780 W 104TH STREET HIALEAH, FL 33018 (305) 593-6590	SERIES 110 ALUM. SINGLE HUNG WINDOW (SM)	Desc.	ELEVATIONS	Sheet	SH110 "SENTINEL"

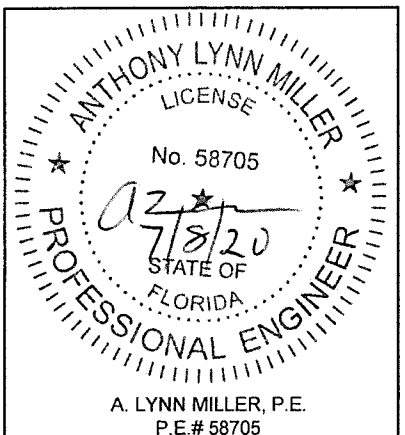

A. LYNN MILLER, P.E.
P.E.# 58705

EQUAL LITES WINDOWS					
DESIGN LOAD CAPACITY - PSF					
FLANGE DIMS.		BUCK DIMS.		GLASS TYPES 'C' & 'CI'	
WIDTH	HEIGHT	WIDTH	HEIGHT	EXT.(+)	INT.(-)
19-1/8"	26"	18-1/8"	25"	80.0	134.0
26-1/2"		25-1/2"		80.0	134.0
37"		36"		80.0	134.0
49"		48"		80.0	134.0
53-1/8"		52-1/8"		80.0	134.0
19-1/8"	38-3/8"	18-1/8"	37-3/8"	80.0	134.0
26-1/2"		25-1/2"		80.0	134.0
37"		36"		80.0	134.0
49"		48"		80.0	134.0
53-1/8"		52-1/8"		80.0	134.0
19-1/8"	50-5/8"	18-1/8"	49-5/8"	80.0	134.0
26-1/2"		25-1/2"		80.0	134.0
37"		36"		80.0	134.0
49"		48"		80.0	124.3
53-1/8"		52-1/8"		80.0	110.4
19-1/8"	63"	18-1/8"	62"	80.0	134.0
26-1/2"		25-1/2"		80.0	134.0
37"		36"		80.0	134.0
49"		48"		80.0	109.9
53-1/8"		52-1/8"		80.0	96.5
19-1/8"	76"	18-1/8"	75"	80.0	105.0
26-1/2"		25-1/2"		80.0	105.0
37"		36"		80.0	105.0
49"		48"		80.0	102.1
53-1/8"		52-1/8"		80.0	88.3
19-1/8"	85"	18-1/8"	84"	80.0	105.0
26-1/2"		25-1/2"		80.0	105.0
37"		36"		80.0	105.0
46-1/2"		45-1/2"		80.0	105.0

UNEQUAL LITES WINDOWS						
DESIGN LOAD CAPACITY - PSF						
FLANGE DIMS.		BUCK DIMS.		MAX.TOP LITE	GLASS TYPES 'C' & 'CI'	
WIDTH	HEIGHT	WIDTH	HEIGHT	'A' DIM.	EXT.(+)	INT.(-)
53-1/8"	53"	52-1/8"	52"	28-1/2"	80.0	110.4
49"	63"	48"	62"	31"	80.0	109.9
43"	71"	42"	70"	35-3/8"	80.0	134.0
37"	83"	36"	82"	41-3/8"	80.0	134.0
26-1/2"	85"	25-1/2"	84"	58-3/8"	80.0	134.0
31"		30"		46-5/8"	80.0	134.0
33"		32"		45-1/2"	80.0	134.0
53-1/8"	76"	52-1/8"	75"	36-1/4"	80.0	83.3
49"	79"	48"	78"	39-1/4"	80.0	83.3
37"	85"	36"	84"	53-1/2"	80.0	105.0
43"		42"		45-1/4"	80.0	105.0

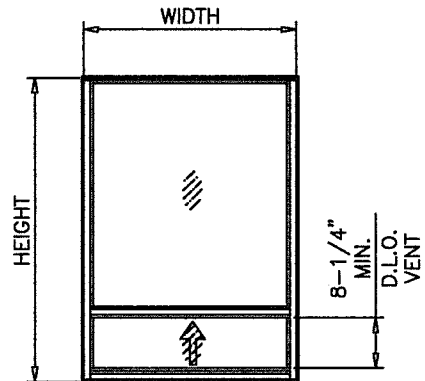

UNEQUAL LITES (ORIEL TYPE)

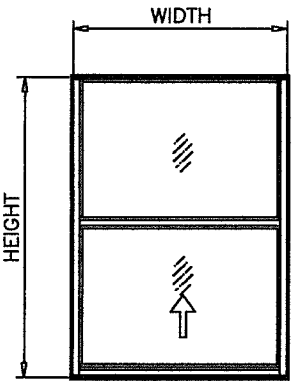

EQUAL LITES

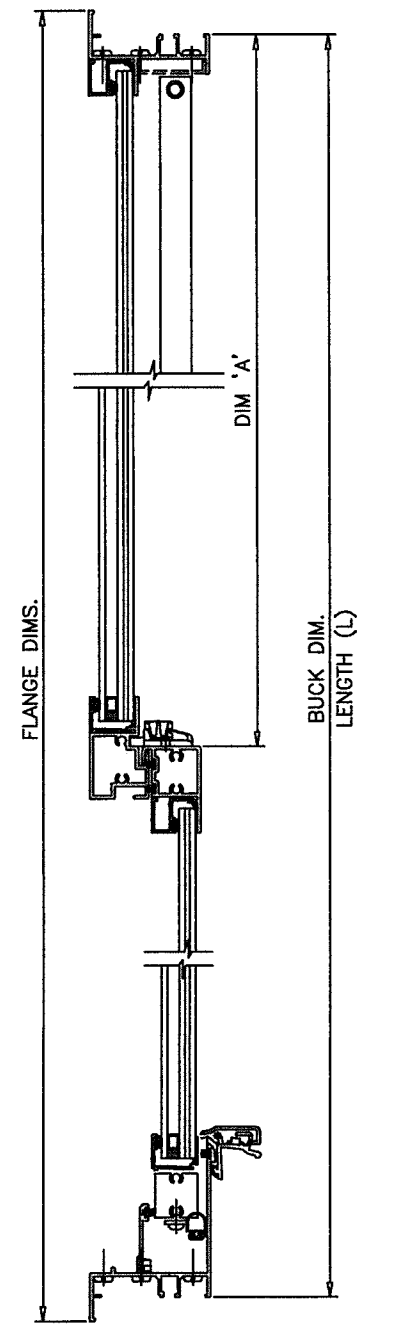
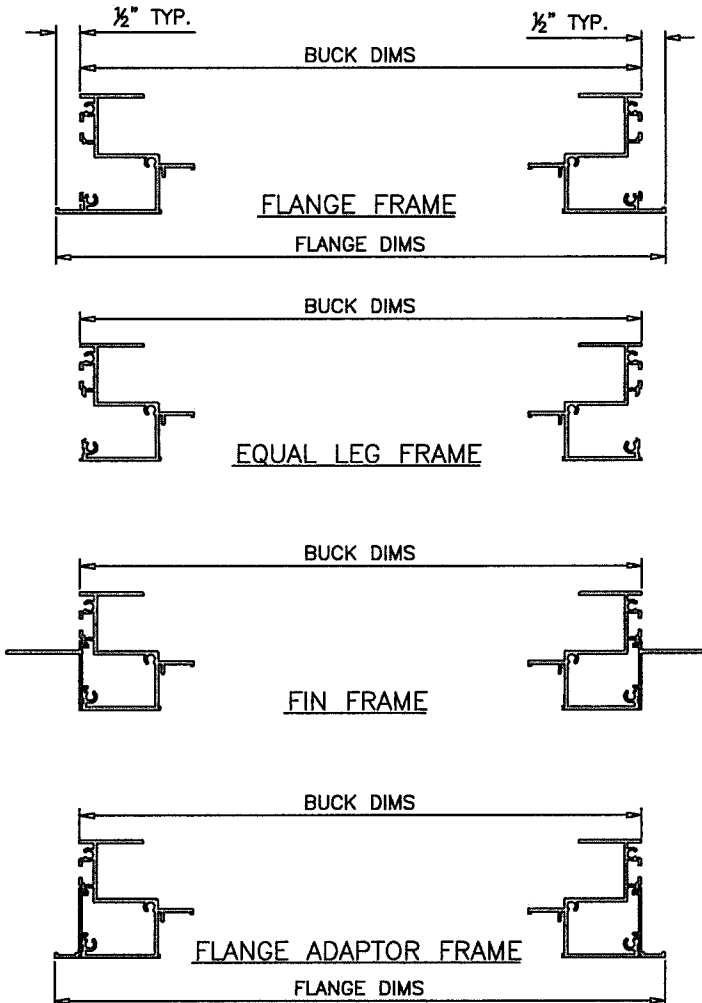

UNEQUAL LITES (ORIEL TYPE)

NOTE:
GLASS CAPACITIES ON THIS SHEET ARE BASED ON ASTM E1300-09 (3 SEC. GUSTS) AND FLORIDA BUILDING COMMISSION DECLARATORY STATEMENT DCA05-DEC-219.

PRODUCT REVISED
as complying with the Florida Building Code
NOA-No. **20-0722.10**
Expiration Date: **11/13/2024**
By: *Manuel Perez*
Miami-Dade Product Control

Revision:

PREPARED BY A. LYNN MILLER 1070 TECHNOLOGY DRIVE N. VENICE, FL 34275 (941) 480-1600	Date	07/02/20	REGISTRATION #29296	JENS ROSOWSKI	Rev. A
	By	JENS ROSOWSKI			
Impact Resistant Windows & Doors WERE STRONGER™ CGI WINDOWS AND DOORS, INC. 3780 W 104TH STREET HIALEAH, FL 33018 (305) 593-6590	SERIES 110 ALUM. SINGLE HUNG WINDOW (SM)		DESIGN LOADS	SH110 "SENTINEL"	2 OF 9
	Title				
DWC No.		SH110-SM-NOA			
Sheet		2 OF 9			

ANTHONY LYNN MILLER
LICENSE
No. 58705
7/8/20
STATE OF FLORIDA
PROFESSIONAL ENGINEER
A. LYNN MILLER, P.E.
P.E.# 58705

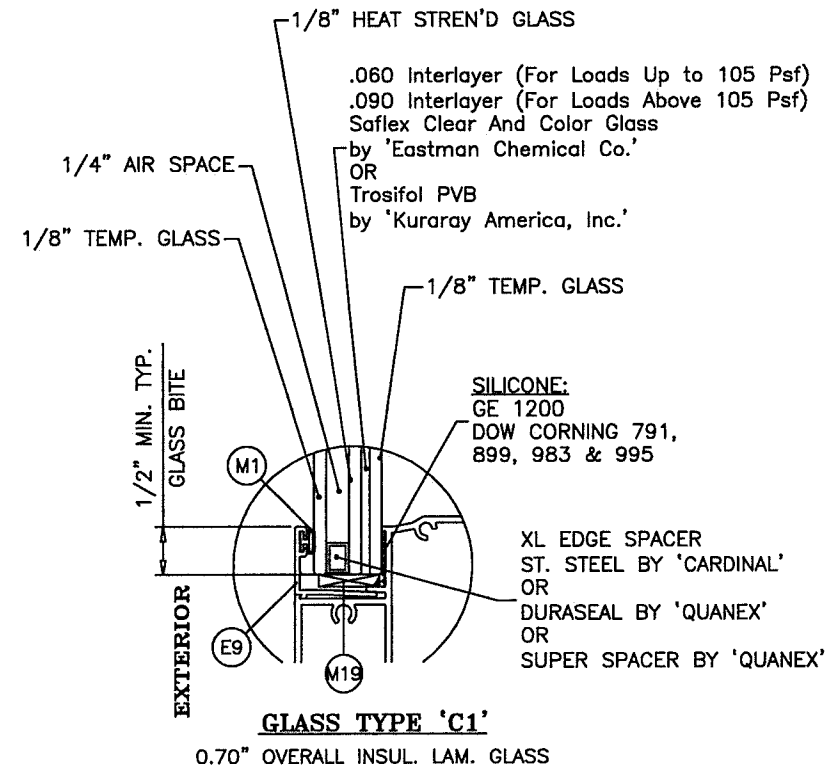
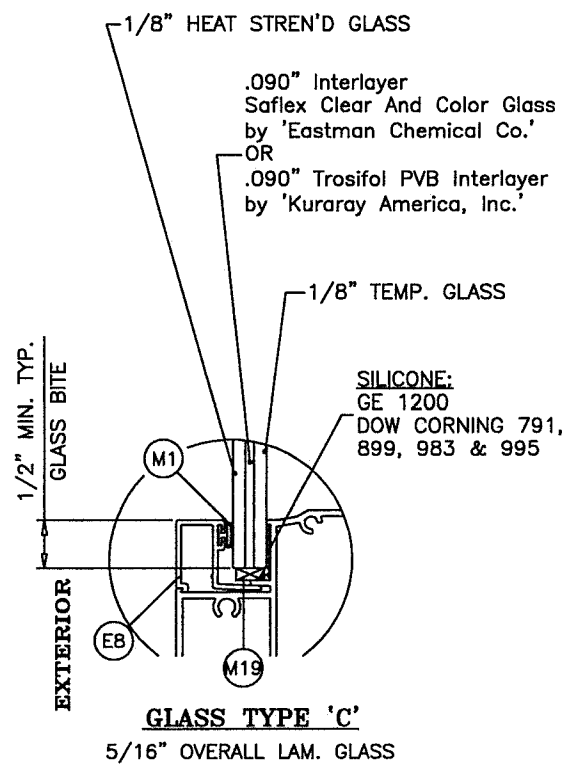

PRODUCT REVISED
as complying with the Florida
Building Code
NOA-No. **20-0722.10**
Expiration Date: **11/13/2024**
By: *Manuel Perez*
Miami-Dade Product Control

ADDED BACKBEDDING
TYPES - JR - 07/07/20

Revision:

Impact Resistant Windows & Doors WERE STRONGER™ CGI WINDOWS AND DOORS, INC. 3780 W 104TH STREET HIALEAH, FL 33018 (305) 593-6690	PREPARED BY A. LYNN MILLER 1070 TECHNOLOGY DRIVE N. VENICE, FL 34275 (941) 480-1600	REGISTRATION #29296 07/02/20	JENS ROSOWSKI A
	SERIES 110 ALUM. SINGLE HUNG WINDOW (SM)	DWG No. SH110-SM-NOA	Date 07/02/20
GLASS OPTIONS SH110 "SENTINEL"	3 OF 9	Drawn By JENS ROSOWSKI	Sheet No. SH110-SM-NOA
Series Desc. Title	Series Desc. Title	Series Desc. Title	Series Desc. Title

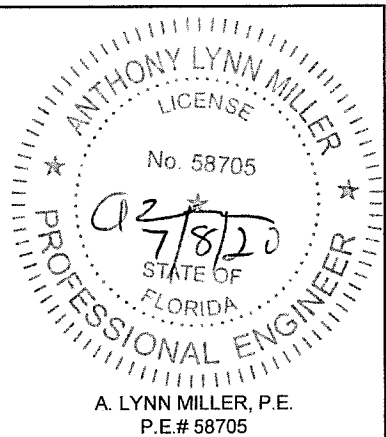

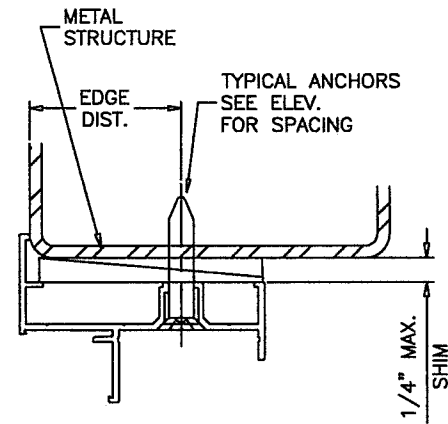
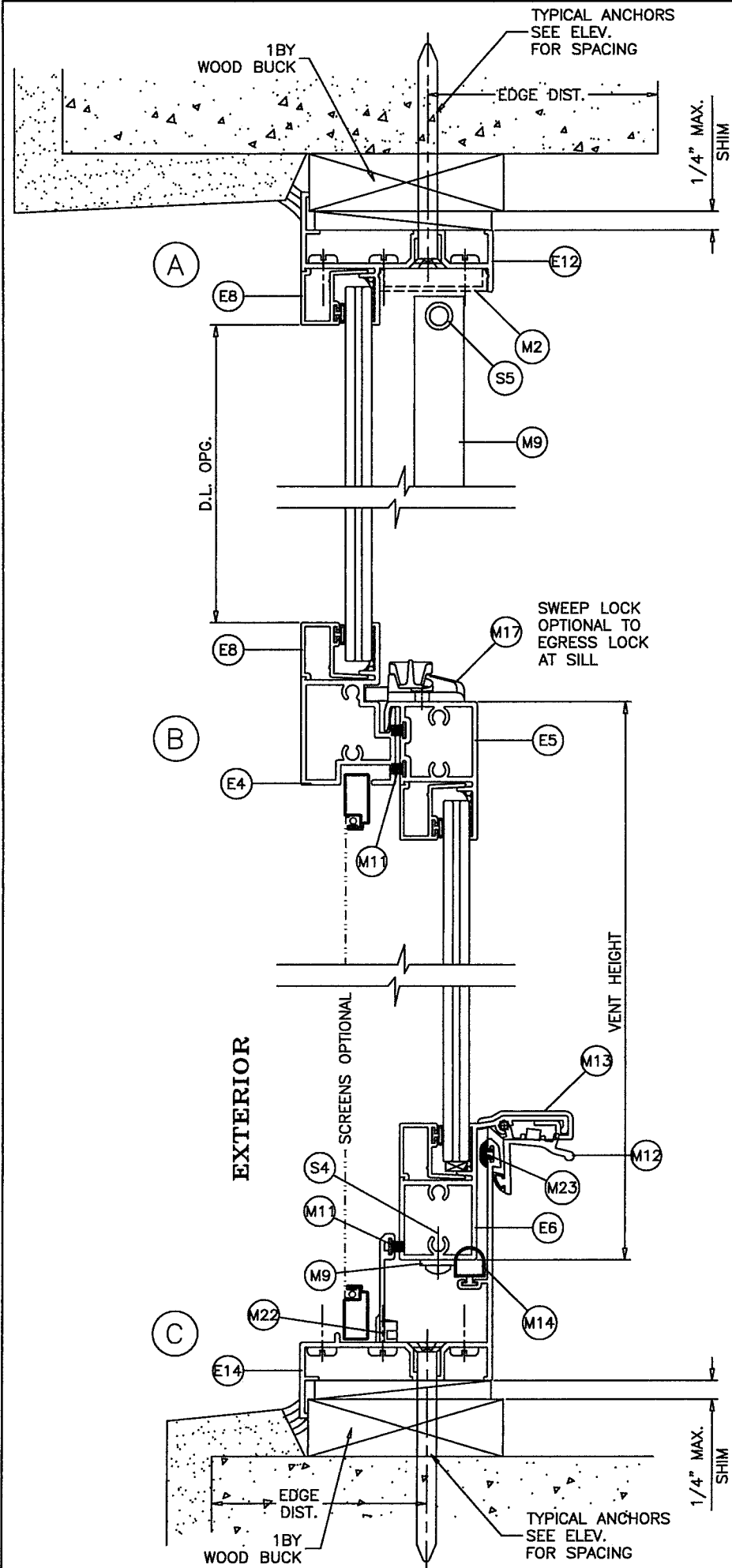

FLANGE & FLANGE ADAPTOR FRAME

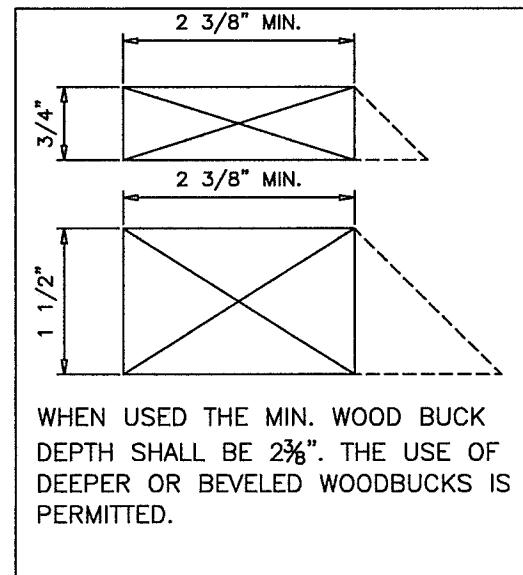
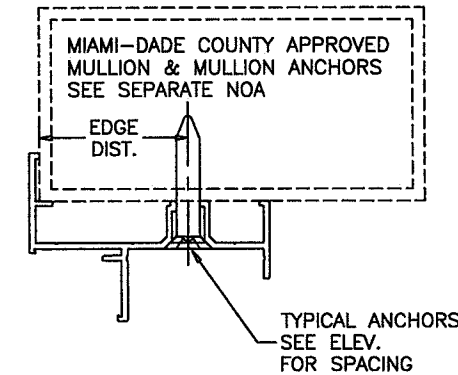
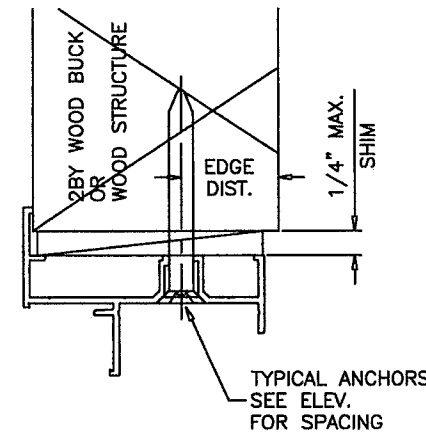

WOOD BUCKS AND METAL STRUCTURE NOT BY CGI WDW. MUST SUSTAIN LOADS IMPOSED BY GLAZING SYSTEM AND TRANSFER THEM TO THE BUILDING STRUCTURE.

TYPICAL ANCHORS: SEE ELEV. FOR SPACING

- 1/4" DIA. TAPCON BY 'ITW' (Fu=125 KSI, Fy=100 KSI)
- 1/4" DIA. ULTRACON BY 'ELCO' (Fu=177 KSI, Fy=155 KSI)
- 1/4" DIA. ULTRACON+ BY 'DEWALT' (Fu=164 KSI, Fy=148 KSI)

INTO 2BY WOOD BUCKS OR WOOD STRUCTURES

- 1-3/8" MIN. PENETRATION INTO WOOD
- THRU 1BY BUCKS INTO CONC. OR BLOCKS
- 1-1/4" MIN. EMBED INTO CONCRETE (HEAD/SILL/JAMBS)
- 1-1/4" MIN. EMBED INTO BLOCKS (JAMBS)

DIRECTLY INTO CONCRETE OR BLOCKS

- 1-1/4" MIN. EMBED INTO CONCRETE (HEAD/SILL/JAMBS)
- 1-1/4" MIN. EMBED INTO BLOCKS (JAMBS)

#14 SMS OR SELF DRILLING SCREWS (Fu=74 KSI, Fy=57 KSI)

- INTO MIAMI-DADE COUNTY APPROVED MULLIONS OR INTO METAL STRUCTURES (HEAD/SILL/JAMBS)
- (3) THREADS MIN. PENETRATION BEYOND SUBSTRATE

- ALUMINUM : 1/8" THK. MIN. (6063-T5 MIN.)
- STEEL : 1/8" THK. MIN. (Fy = 36 KSI MIN.)
- (STEEL IN CONTACT WITH ALUMINUM TO BE PLATED OR PAINTED)

TYPICAL EDGE DISTANCE

- INTO CONCRETE AND MASONRY = 2-1/2" MIN.
- INTO WOOD STRUCTURE = 1" MIN.
- INTO METAL STRUCTURE = 3/4" MIN.

- WOOD AT HEAD, SILL OR JAMBS SG=0.55 MIN.
- CONCRETE AT HEAD, SILL OR JAMBS f'c = 3000 PSI MIN.
- C-90 HOLLOW/FILLED BLOCK AT JAMBS f'm = 2000 PSI MIN.

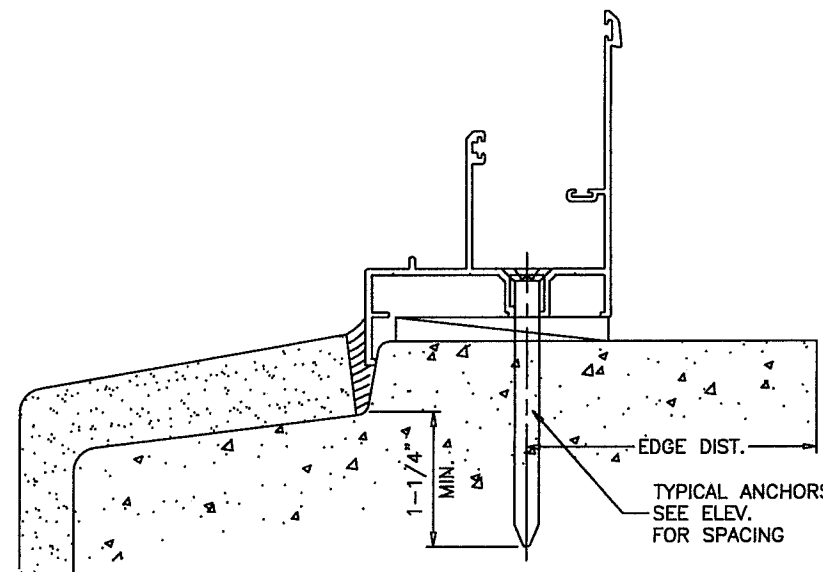

PRODUCT REVISED
as complying with the Florida Building Code
NOA-No. **20-0722.10**
Expiration Date: **11/13/2024**
By: *Manuel Fern*
Miami-Dade Product Control

Revision: ADDED ANCHOR TYPE - JR - 07/07/20

PREPARED BY A. LYNN MILLER 1070 TECHNOLOGY DRIVE N. VENICE, FL 34275 (941) 480-1600	REGISTRATION #29296	DATE	07/02/20	REV.	A
	SERIES 110 ALUM. SINGLE HUNG WINDOW (SM)	DRAWN BY	JENS ROSOWSKI	DWG. NO.	SH110-SM-NOA
Impact Resistant Windows & Doors WERE STRONGER™ CGI WINDOWS AND DOORS, INC. 3780 W 104TH STREET HIALEAH, FL 33018 (305) 593-6590	SERIES	DESC.	FLANGE DETAILS	SHEET	4 OF 9

ANTHONY LYNN MILLER
LICENSE
No. 58705
7/8/20
STATE OF FLORIDA
PROFESSIONAL ENGINEER
A. LYNN MILLER, P.E.
P.E.# 58705

FLANGE & FLANGE ADAPTOR FRAME

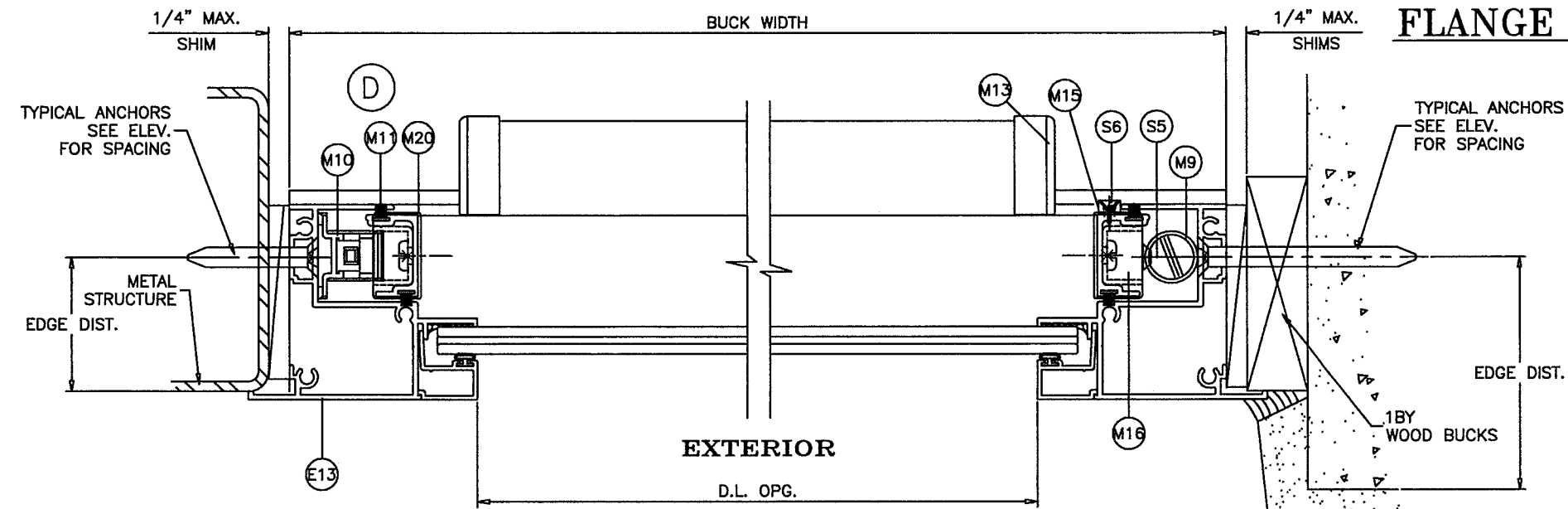

FLANGE ADAPTOR FRAME

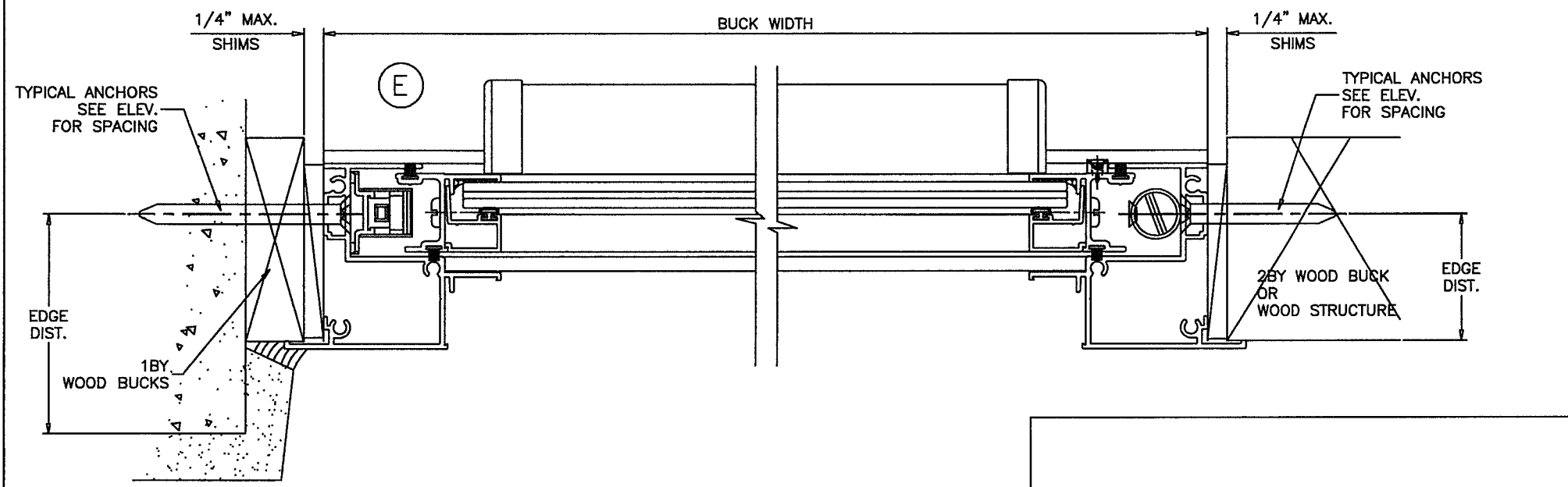
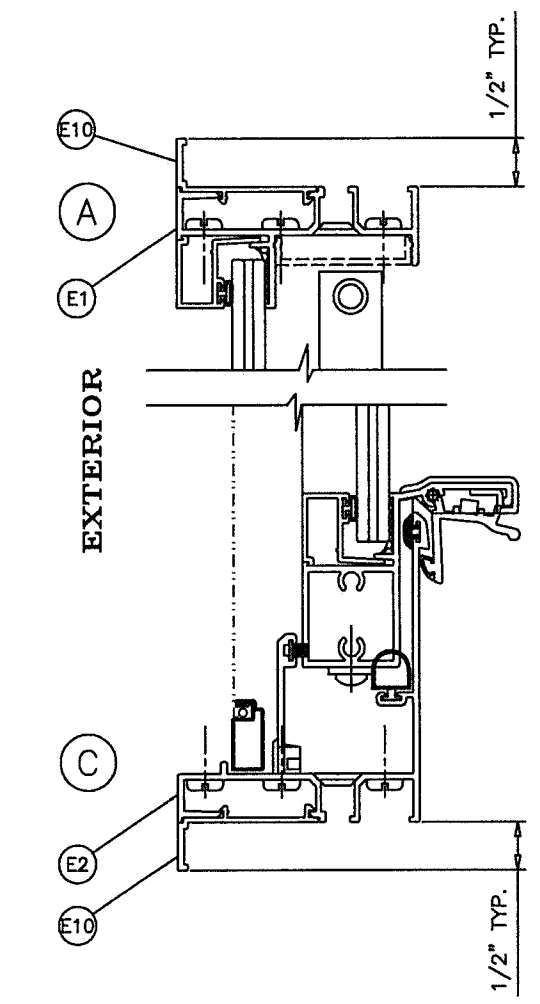

INSTALLATION DETAILS SHOWN ON PAGES 4 AND 5 APPLY TO BOTH FLANGE FRAME AND FLANGE ADAPTOR FRAMES.

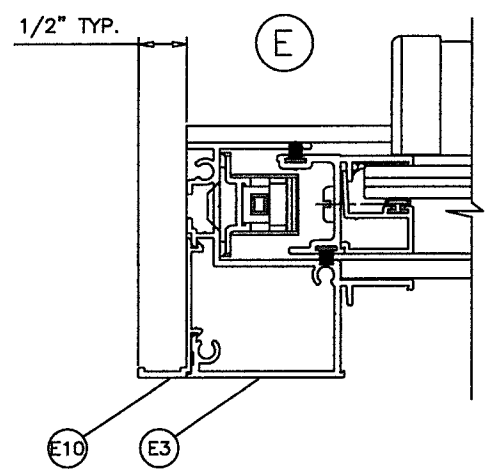
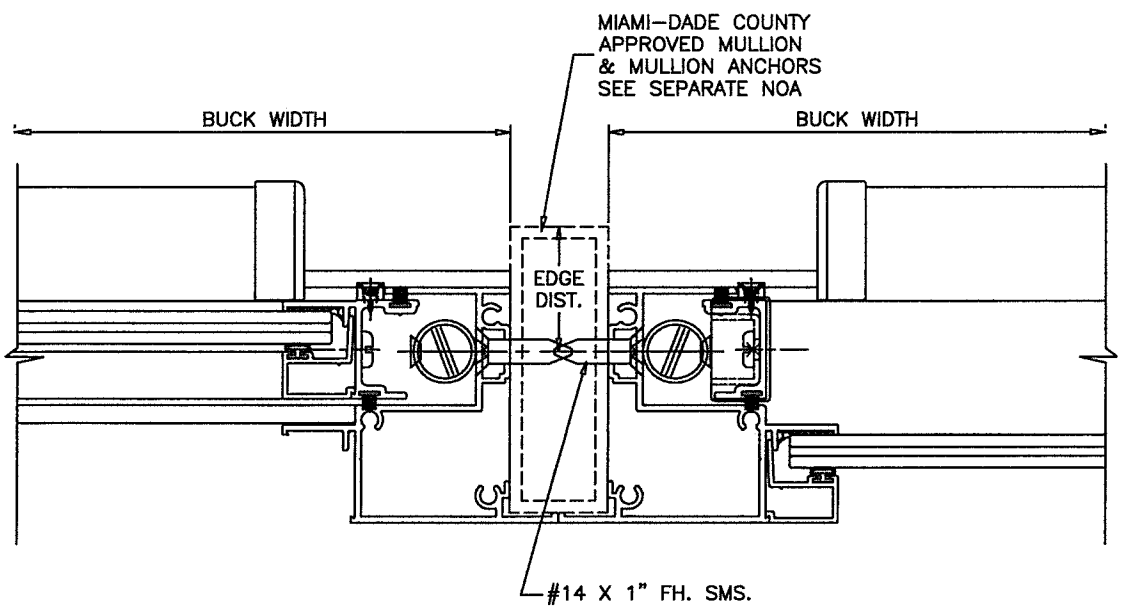

PRODUCT REVISED
 as complying with the Florida Building Code
 NOA-No. **20-0722.10**
 Expiration Date: **11/13/2024**
 By: *Manuel Perez*
 Miami-Dade Product Control

Revision:

PREPARED BY A. LYNN MILLER 1070 TECHNOLOGY DRIVE N. VENICE, FL 34275 (941) 480-1600	REGISTRATION #29296	Date	07/02/20	Rev.	A
	SERIES 110 ALUM. SINGLE HUNG WINDOW (SM)	Drawn By	JENS ROSOWSKI	DWG No.	SH110-SM-NOA
Impact Resistant Windows & Doors WERE STRONGER™ CGI WINDOWS AND DOORS, INC. 3780 W 104TH STREET HIALEAH, FL 33018 (305) 593-6590	FLANGE DETAILS	Sheet	5 OF 9		
	SH110 "SENTINEL"	Series Desc.			

ANTHONY LYNN MILLER
 LICENSE
 No. 58705
 7/8/20
 STATE OF FLORIDA
 PROFESSIONAL ENGINEER
 A. LYNN MILLER, P.E.
 P.E.# 58705

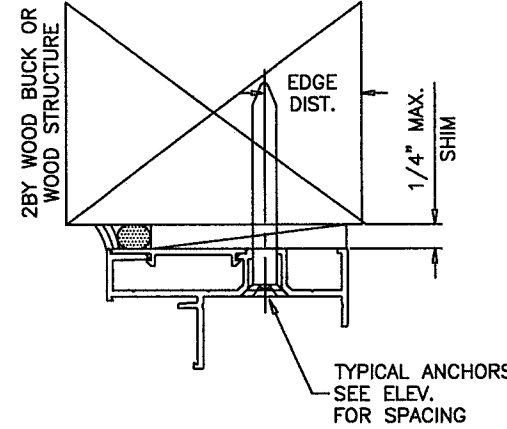
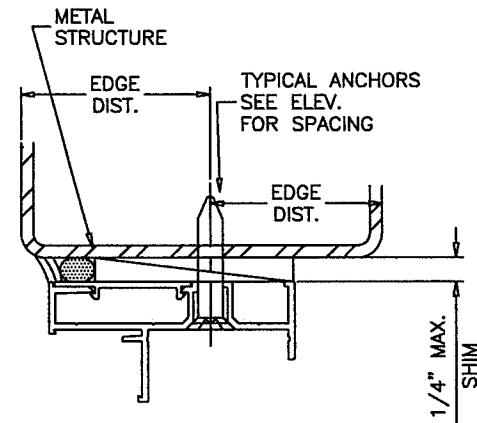
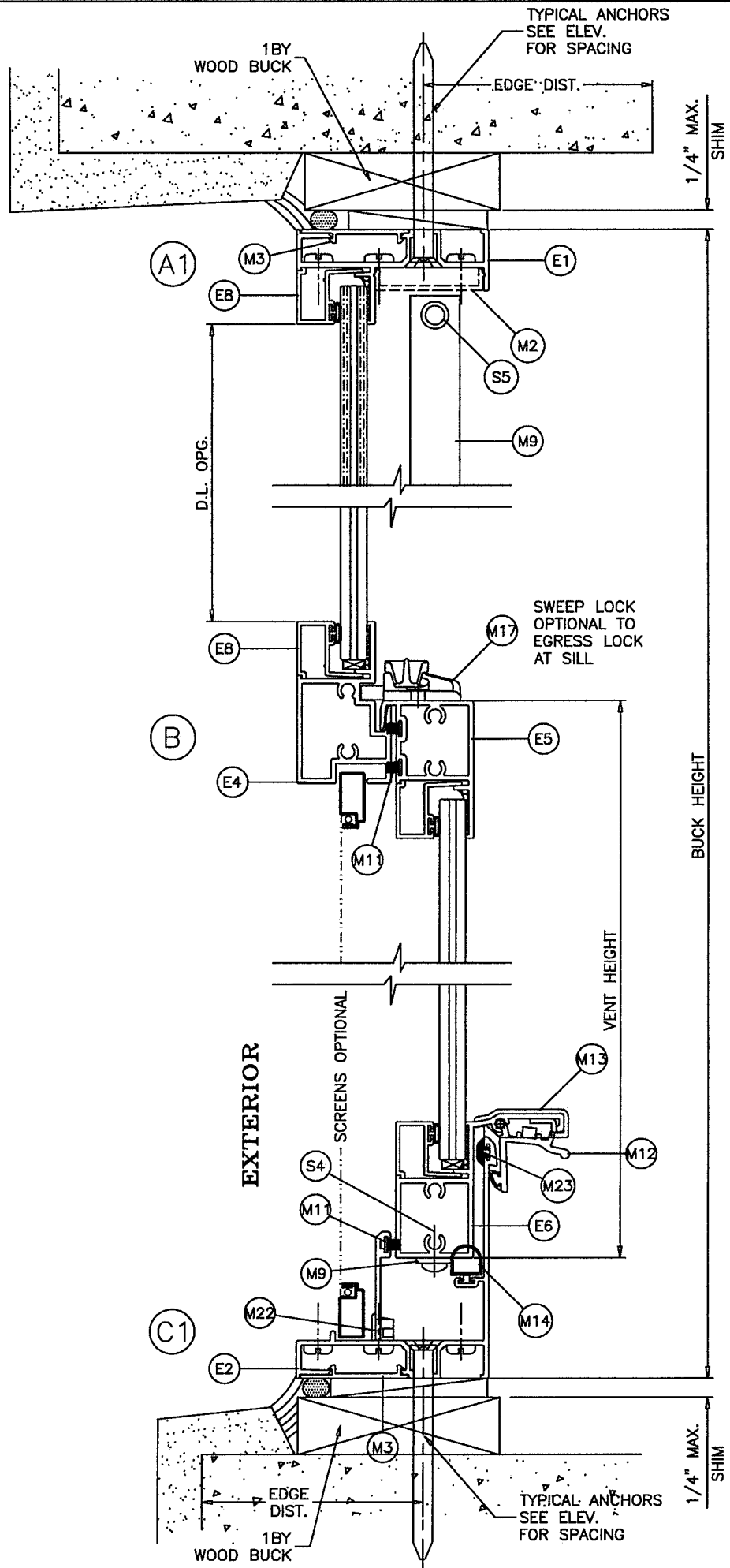

EQUAL LEG FRAME

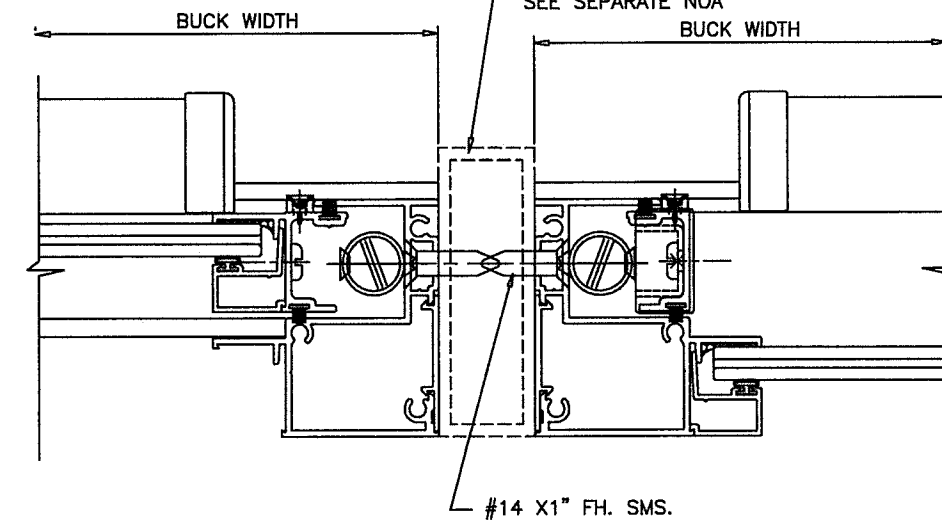
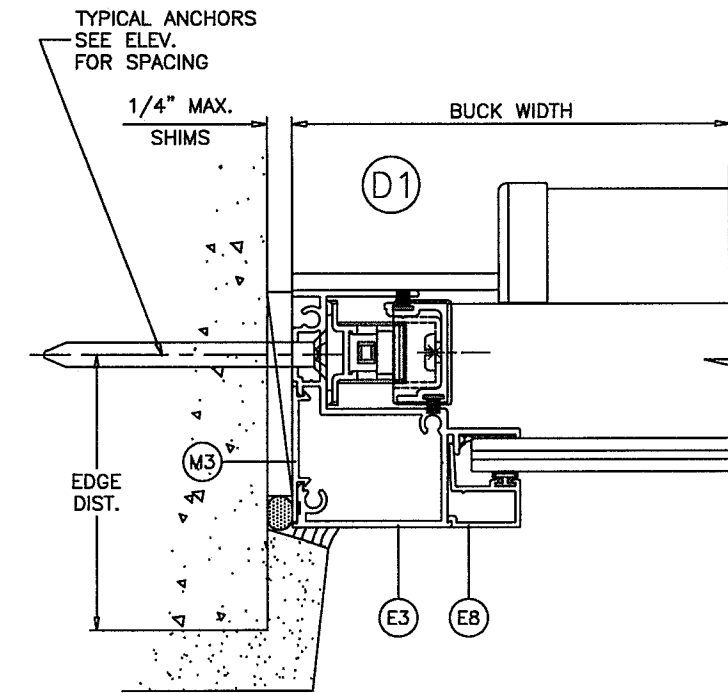
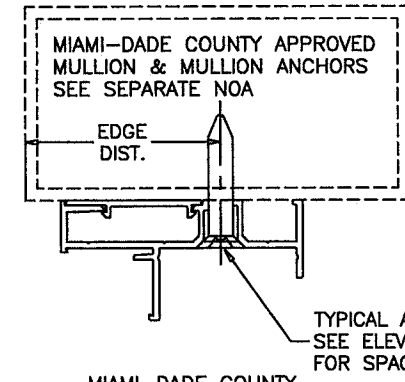

EQUAL LEG FRAME CAN BE INSTALLED DIRECTLY INTO WOOD, CONCRETE OR METAL STRUCTURES WITHOUT THE NEED OF A WOOD BUCK.

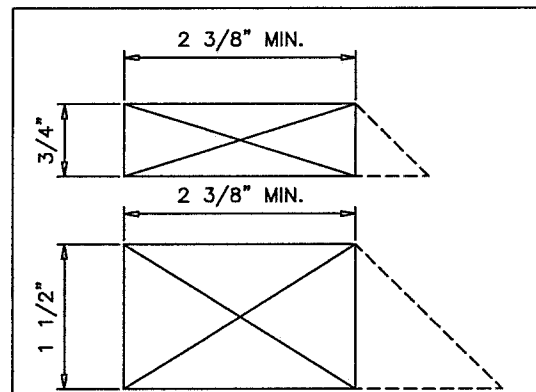

WHEN USED THE MIN. WOOD BUCK DEPTH SHALL BE 2 3/8\". THE USE OF DEEPER OR BEVELED WOODBUCKS IS PERMITTED.

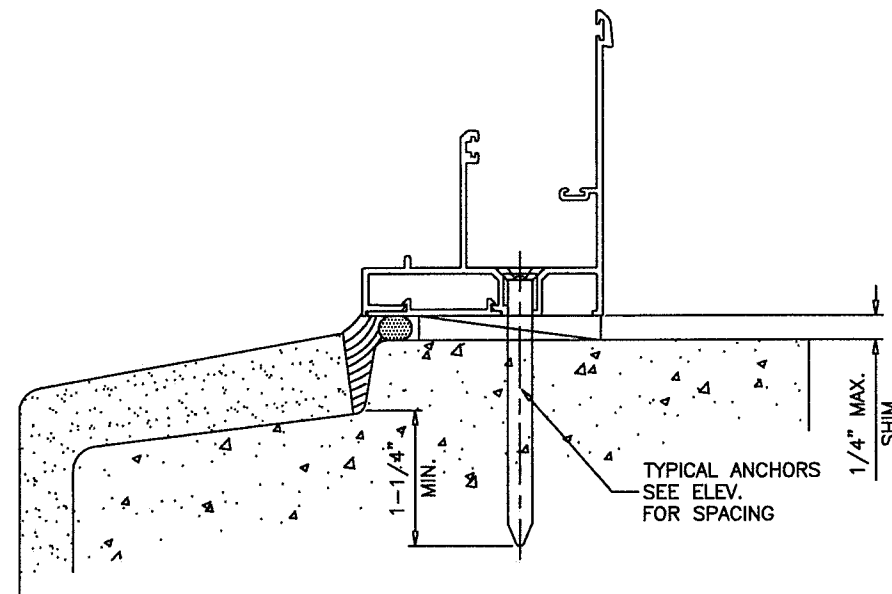

PRODUCT REVISED
 as complying with the Florida Building Code
NOA-No. 20-0722.10
 Expiration Date: **11/13/2024**
 By: *Manuel Perez*
 Miami-Dade Product Control

PREPARED BY A. LYNN MILLER 1070 TECHNOLOGY DRIVE N. VENICE, FL 34275 (941) 480-1600 REGISTRATION #29296	Date	07/02/20	Drawn By JENS ROSOWSKI	Dwg No. SH110-SM-NOA	Rev. A
	SERIES 110 ALUM. SINGLE HUNG WINDOW (SM)				
Impact Resistant Windows & Doors WERE STRONGER™ CGI WINDOWS AND DOORS, INC. 3780 W 104TH STREET HIALEAH, FL 33018 (305) 593-6590	EQUAL LEG DETAILS		Sheet 6 OF 9	No.	Title
	SH110 "SENTINEL"				

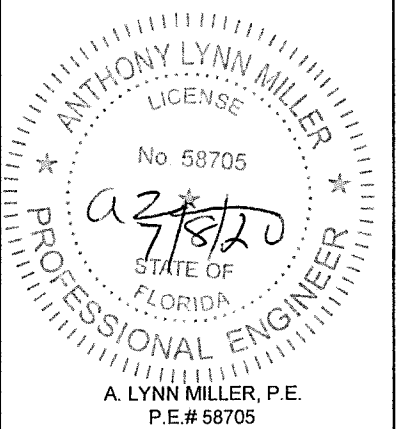

FIN FRAME

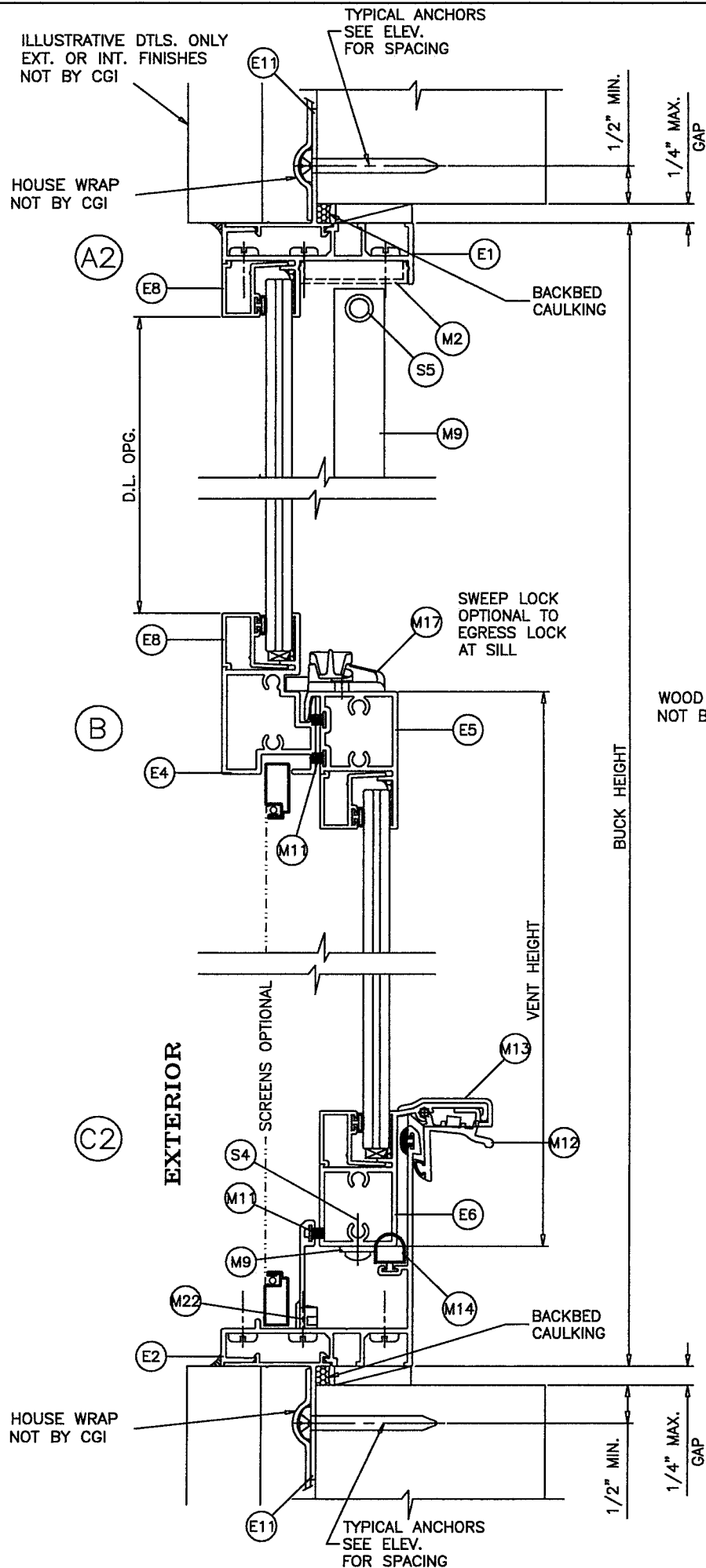

TYPICAL ANCHORS: SEE ELEV. FOR SPACING
 #8 SMS (Fu=74 KSI, Fy=57 KSI)
 INTO 2BY WOOD BUCKS OR WOOD STRUCTURES
 1-1/4" MIN. PENETRATION INTO WOOD

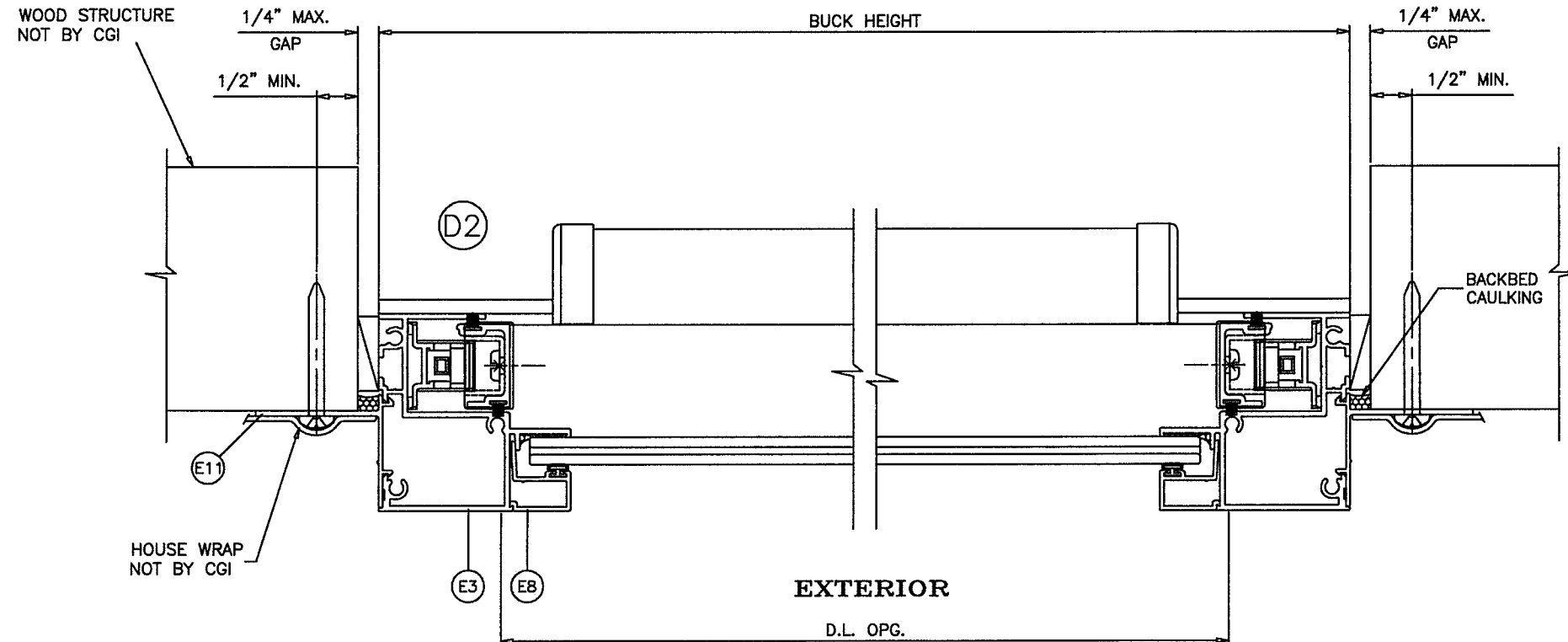

PRODUCT REVISED
 as complying with the Florida Building Code
 NOA-No. **20-0722.10**
 Expiration Date: **11/13/2024**
 By: *Manuel Perez*
 Miami-Dade Product Control

Revision:

PREPARED BY A. LYNN MILLER 1070 TECHNOLOGY DRIVE N. VENICE, FL 34275 (941) 480-1600 REGISTRATION #29296	Date	07/02/20
	Drawn By	JENS ROSOWSKI
Impact Resistant Windows & Doors WERE STRONGER™ CGI WINDOWS AND DOORS, INC. 3780 W 104TH STREET HIALEAH, FL 33018 (305) 593-6590	No.	SH110-SM-NOA
	Sheet	7 OF 9
Series	SH110 "SENTINEL"	A
SERIES 110 ALUM. SINGLE HUNG WINDOW (SM) FIN DETAILS		

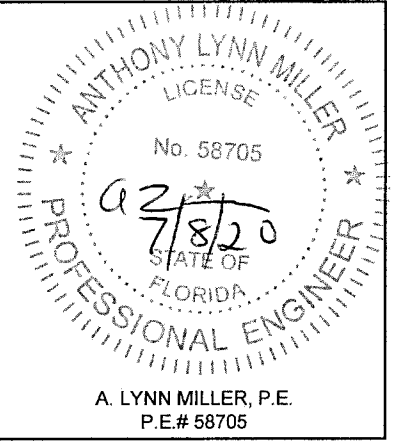

A. LYNN MILLER, P.E.
 P.E.# 58705

ITEM	PART #	QUANTITY	DESCRIPTION	MATERIAL	MANF./SUPPLIER/REMARKS
E1	CGI-100	1	FRAME HEAD	6063-T6	-
E2	CGI-101	1	FRAME SILL	6063-T6	-
E3	CGI-102	2	FRAME JAMB	6063-T6	-
E4	CGI-103	1	MEETING RAIL	6063-T6	-
E5	CGI-104	1	LOCK RAIL	6063-T6	-
E6	CGI-105	1	HANDLE RAIL	6063-T6	-
E7	CGI-106	2	SASH RAIL	6063-T6	-
E8	CGI-107	AS REQD.	5/16" GLAZING BEAD	6063-T5	-
E9	CGI-108	AS REQD.	0.700" GLAZING BEAD	6063-T5	-
E10	CGI-109	AS REQD.	FRONT FLANGE ADAPTOR	6063-T6	-
E11	CGI-110	AS REQD.	NAIL FIN ADAPTOR	6063-T5	-
E12	CGI-135	1	FLANGE FRAME HEAD	6063-T6	-
E13	CGI-136	2	FLANGE FRAME JAMB	6063-T6	-
E14	CGI-137	1	FLANGE FRAME SILL	6063-T6	-
E17	CGI-605	OPTIONAL	SCREEN FRAME	6063-T5	-
M1	CGI-382V	AS REQD.	GLAZING BULB VINYL (DUROMETER 75-80 SHORE A)	PVC	-
M2	CGI-111	OPTIONAL	SCREW COVER	PVC	PROTOTYPE OR EQUIV.
M3	CGI-112	AS REQD.	EQUAL LEG COVER/SHIM, 3" LONG AT ANCHOR LOCATIONS	PVC	-
M9	SUPER BOOST	2/ WDW.	SPIRAL BALANCE	-	BSI OR EQUIV.
M10	-	2/ WDW.	BLOCK/TACKLE BALANCE	-	BSI OR EQUIV.
M11	W23201NG	AS REQD.	PILE WITH CENTER FIN	WOOL	ULTRAFAB OR EQUIV.
M12	CGI-129	1/ WDW.	EGRESS LOCK	ALUM.	SULLIVAN
M13	CGI-131	2/ WDW.	HANDLE RAIL END CAP	NYLON	M&M
M14	E26018WN	-	D BULB-T SLOT	PVC	ULTRAFAB OR EQUIV.
M15	CGI-133	4/ WDW.	SASH GUIDE(SPIRAL BALANCE)	NYLON	M&M
M16	CGI-130	2/ WDW.	SASH TOP GUIDE(SPIRAL BALANCE)	NYLON	M&M
M17	A30730401-32	1/ WDW.	CAM LOCK	ZINC	TRUTH OR EQUIV.
M18	CGI-132	2/ WDW.	SASH STOP, 2" LONG	PVC	PROTOTYPE OR EQUIV.
M19	-	2/ LITE	SETTING BLOCK	EPDM	DUROMETER 85±5 SHORE A
M20	CGI-125	2/ WDW.	SASH CAM (B/T BALANCE)	NYLON	M&M
M21	-	2/ WDW.	B/T BALANCE TAKE OUT CLIP	-	BSI OR EQUIV.
M22	146-6	2/ WDW.	WEEP COVER	NYLON	AMESBURY OR EQUIV
M23	CGI-134	-	SILL SPACER	PVC	PROTOTYPE OR EQUIV.
S2	-	2 OR 3/CORNER	# 10 X 1 1/4" LG. PHL. PH. SMS. ST/ST. ASSEMBLY SCREW	-	-
S4	-	4/ WDW.	# 8 X 1/2" PH. SMS. ST/ST BALANCE BRACKET SCREW	-	-
S5	-	2/ WDW.	# 8 X 1" LG. FH. SMS. ST/ST. SPIRAL B. ASSEMBLY	-	-
S6	-	2/ LOCK	# 6 X 1/2" LG. FH. SMS. @ CGI-133 & CAM LOCK	-	-

PRODUCT REVISED
as complying with the Florida
Building Code
NOA-No. **20-0722.10**
Expiration Date: **11/13/2024**
By: *Manuel Perez*
Miami-Dade Product Control

Revision:

PREPARED BY A. LYNN MILLER 1070 TECHNOLOGY DRIVE N. VENICE, FL 34275 (941) 480-1600 REGISTRATION #29296	Date	07/02/20	By JENS ROSOWSKI	Rev. A
	SERIES 110 ALUM. SINGLE HUNG WINDOW (SM)			
Impact Resistant Windows & Doors WE'RE STRONGER™ CGI WINDOWS AND DOORS, INC. 3780 W 104TH STREET HIALEAH, FL 33018 (305) 593-6590	SERIES 110 ALUM. SINGLE HUNG WINDOW (SM)		DWG No. 8 OF 9	Sheet SH110 "SENTINEL"
	BILL OF MATERIALS			

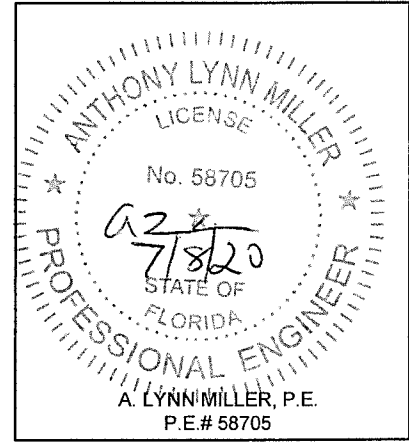

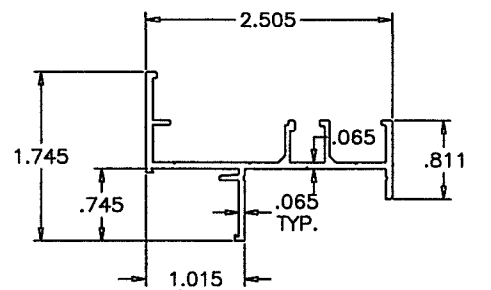

E12 FLANGE FRAME HEAD

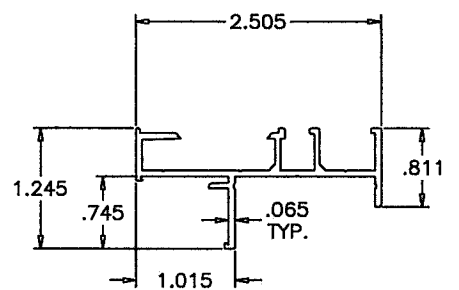

E1 FLUSH FRAME HEAD

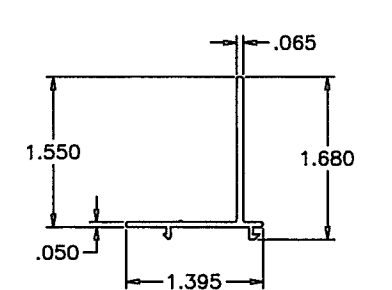

E11 NAIL FIN ADAPTER

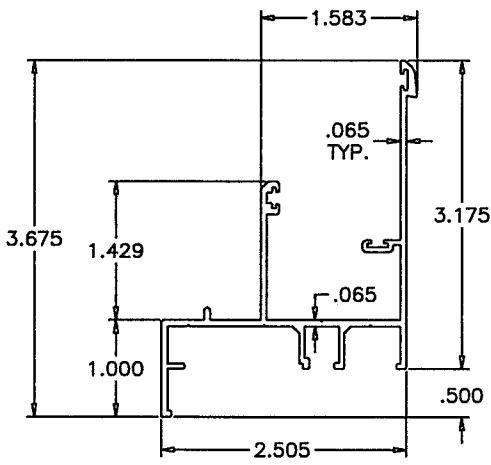

E14 FLANGE FRAME SILL

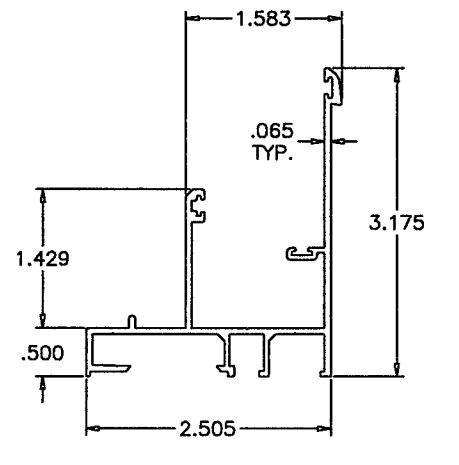

E2 FLUSH FRAME SILL

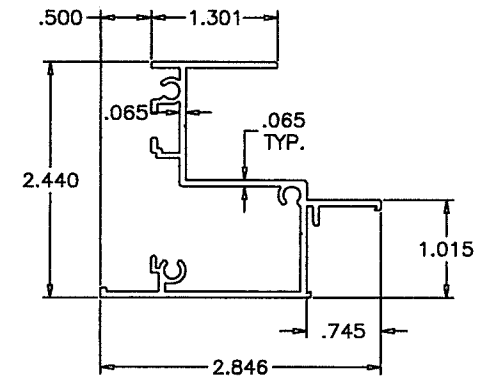

E13 FLANGE FRAME JAMB

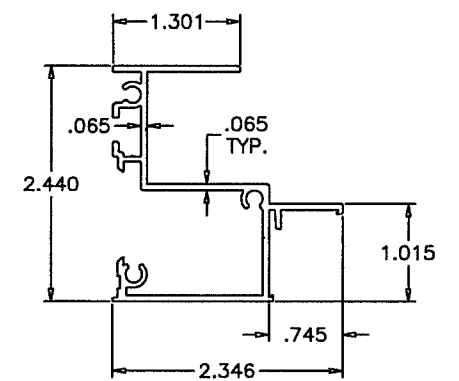

E3 FLUSH FRAME JAMB

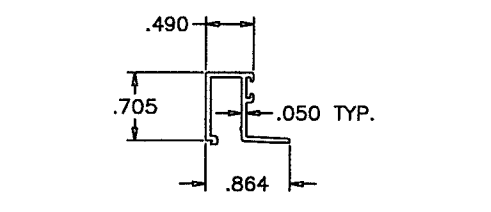

E8 5/16" GLAZING BEAD

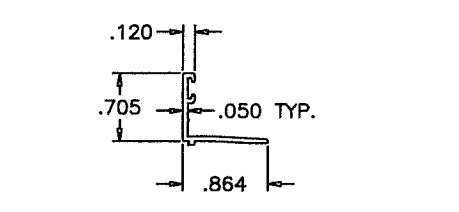

E9 .700" GLAZING BEAD

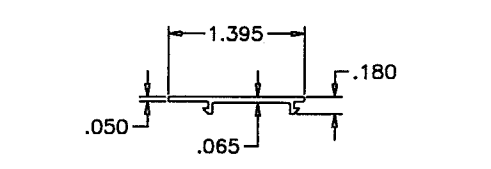

M3 FLUSH FRAME COVER

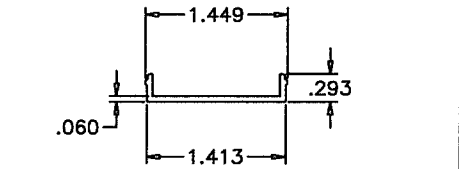

M19 SCREW COVER

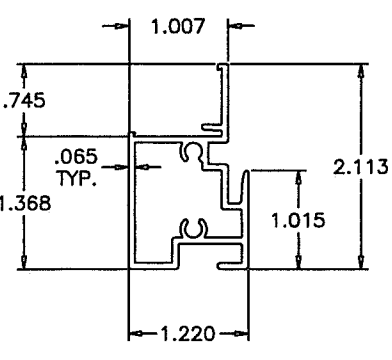

E4 MEETING RAIL

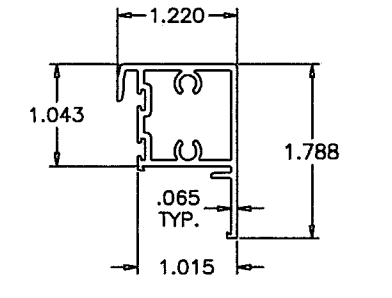

E5 LOCK RAIL

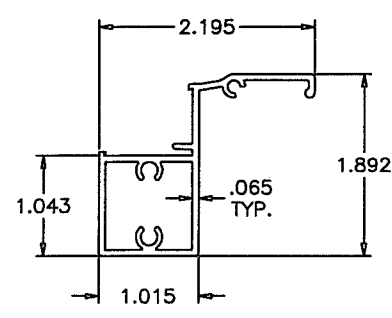

E6 HAND RAIL

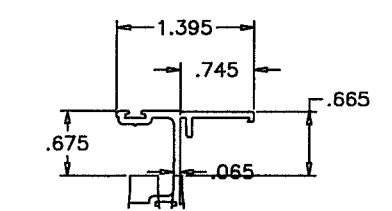

E7 SASH RAIL

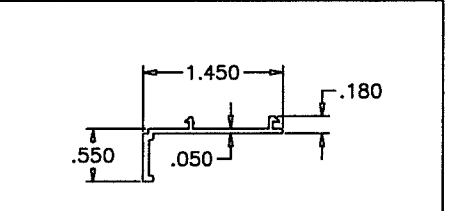

E10 FLANGE ADAPTOR

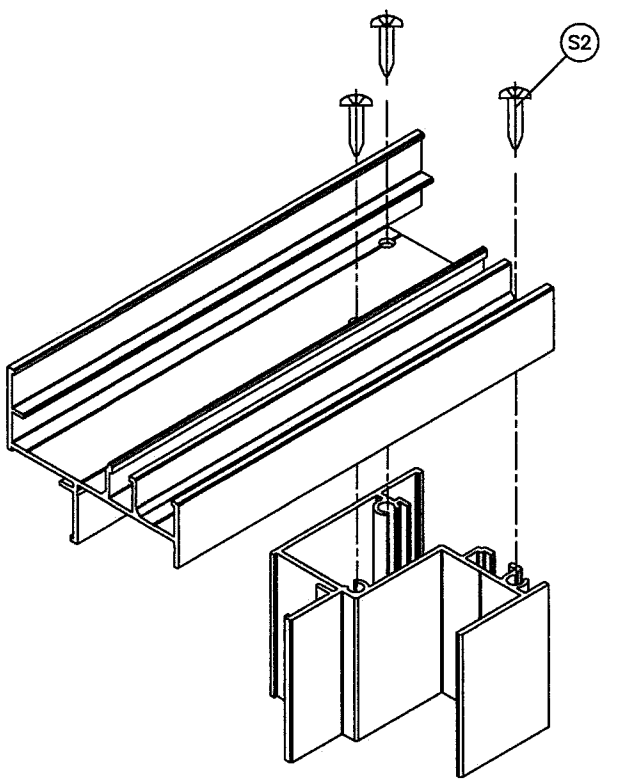

FRAME TOP CORNER

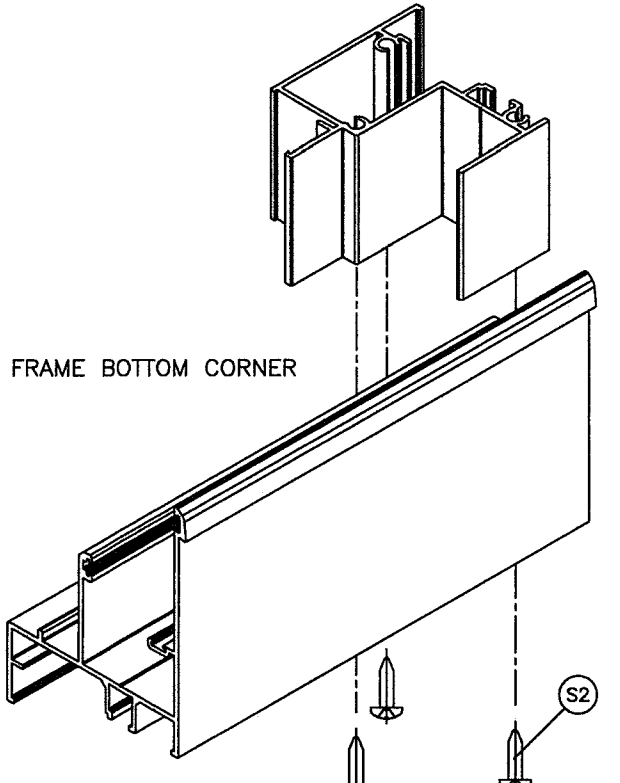

FRAME BOTTOM CORNER

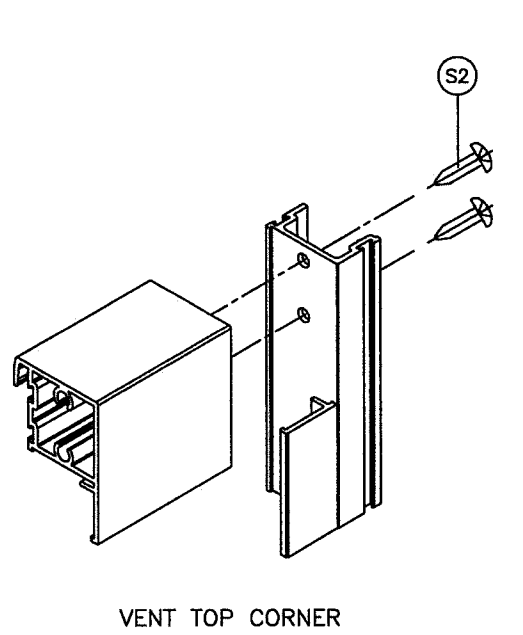

VENT TOP CORNER

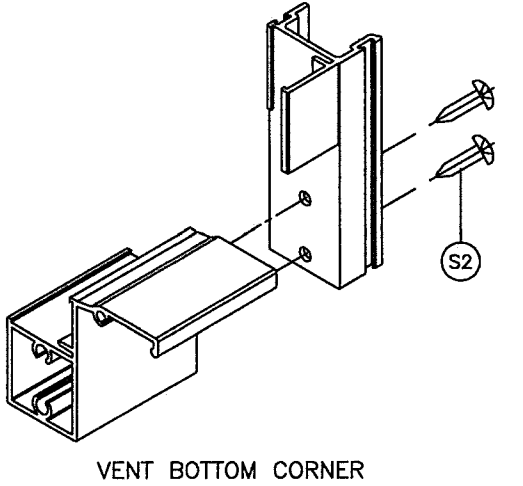

VENT BOTTOM CORNER

PRODUCT REVISED
 as complying with the Florida
 Building Code
 NOA-No. **20-0722.10**
 Expiration Date: **11/13/2024**
 By: *Manuel Perez*
 Miami-Dade Product Control

Revisior:

PREPARED BY A. LYNN MILLER 1070 TECHNOLOGY DRIVE N. VENICE, FL 34275 (941) 480-1600	REGISTRATION #29296	DATE	07/02/20	REV.	A
	SERIES 110 ALUM. SINGLE HUNG WINDOW (SM)	BY	JENS ROSOWSKI	DWG. NO.	SH110-SM-NOA
Impact Resistant Windows & Doors WE'RE STRONGER™	CGI WINDOWS AND DOORS, INC. 3780 W 104TH STREET HIALEAH, FL 33018 (305) 593-6590	SHEET	9 OF 9	SERIES	SH110 "SENTINEL"
EXTRUSIONS					

ANTHONY LYNN MILLER
 LICENSE
 No. 58705
 7/8/20
 STATE OF
 FLORIDA
 PROFESSIONAL ENGINEER
 A. LYNN MILLER, P.E.
 P.E.# 58705