



DEPARTMENT OF REGULATORY AND ECONOMIC RESOURCES
 (RER)
 BOARD AND CODE ADMINISTRATION DIVISION
NOTICE OF ACCEPTANCE (NOA)

MIAMI-DADE COUNTY
 PRODUCT CONTROL SECTION
 11805 SW 26 Street, Room 208
 Miami, Florida 33175-2474
 T (786) 315-2590 F (786) 315-2599
www.miamidade.gov/economy

Clopay Corporation
8585 Duke Boulevard
Mason, OH 45040

SCOPE: This NOA is being issued under the applicable rules and regulations governing the use of construction materials. The documentation submitted has been reviewed and accepted by Miami-Dade County RER-Product Control Section to be used in Miami Dade County and other areas where allowed by the Authority Having Jurisdiction (AHJ).

This NOA shall not be valid after the expiration date stated below. The Miami-Dade County Product Control Section (In Miami Dade County) and/or the AHJ (in areas other than Miami Dade County) reserve the right to have this product or material tested for quality assurance purposes. If this product or material fails to perform in the accepted manner, the manufacturer will incur the expense of such testing and the AHJ may immediately revoke, modify, or suspend the use of such product or material within their jurisdiction. RER reserves the right to revoke this acceptance if it is determined by Miami-Dade County Product Control Section that this product or material fails to meet the requirements of the applicable building code.

This product is approved as described herein and has been designed to comply with the Florida Building Code, including the High Velocity Hurricane Zone.

DESCRIPTION: Canyon Ridge/Coachman 2” Intellicore W6 DP38 Steel Sectional Garage Door up to 9’-0” Wide w/ Optional Impact Resistant Lites

APPROVAL DOCUMENT: Drawing No. **104948**, titled “Canyon Ridge/Coachman Intellicore W6 Single Car”, sheets 1 through 3 of 3, dated 08/24/2015, with revision 3 dated 08/01/2020, prepared by Clopay Corporation, signed and sealed by Mark Westerfield, P.E., bearing the Miami-Dade County Product Control revision stamp with the Notice of Acceptance number and expiration date by the Miami-Dade County Product Control Section.

MISSILE IMPACT RATING: Large and Small Missile Impact Resistant

LABELING: A permanent label with the manufacturer’s name or logo, manufacturing address, model number, the positive and negative design pressure rating, indicate impact rated if applicable, installation instruction drawing reference number, approval number (NOA), the applicable test standards, and the statement reading ‘Miami-Dade County Product Control Approved’ is to be located on the door’s side track, bottom angle, or inner surface of a panel.

RENEWAL of this NOA shall be considered after a renewal application has been filed and there has been no change in the applicable building code negatively affecting the performance of this product.

TERMINATION of this NOA will occur after the expiration date or if there has been a revision or change in the materials, use, and/or manufacture of the product or process. Misuse of this NOA as an endorsement of any product, for sales, advertising or any other purposes shall automatically terminate this NOA. Failure to comply with any section of this NOA shall be cause for termination and removal of NOA.

LIMITATION: This approval requires the manufacturer to do testing of all coils used to fabricate door panels. A minimum of 2 specimens shall be cut from each coil and tensile tested according to ASTM E-8 by a Miami-Dade County approved laboratory. Every 3 months, the manufacturer shall mail to this office a copy of the tested reports. Only coils with average yield strength of 32,000 psi or more shall be used to make door panels for Miami-Dade County under this Notice of Acceptance.

ADVERTISEMENT: The NOA number preceded by the words Miami-Dade County, Florida, and followed by the expiration date may be displayed in advertising literature. If any portion of the NOA is displayed, then it shall be done in its entirety.

INSPECTION: A copy of this entire NOA shall be provided to the user by the manufacturer or its distributors and shall be available for inspection at the job site at the request of the Building Official.

This NOA **renews** and **revises** **NOA # 17-0809.29** and consists of this page 1 and evidence pages E-1, E-2 and E-3, as well as approval document mentioned above.

The submitted documentation was reviewed by **Carlos M. Utrera, P.E.**



NOA No 20-0819.03
Expiration Date: November 25, 2025
Approval Date: October 22, 2020

NOTICE OF ACCEPTANCE: EVIDENCE SUBMITTED

1. EVIDENCE SUBMITTED UNDER NOA #15-0922.07

A. DRAWINGS

1. Drawing No. **104948**, titled "Canyon Ridge/Coachman Intellicore W6 Single Car", sheets 1 through 3 of 3, dated 08/24/2015, prepared by Clopay Building Products Company, signed and sealed by Mark Westerfield, P.E.

B. TESTS

1. Addendum letter to Test Report No. **ATLNC 0717.01-14**, dated 05/06/2015, signed and sealed by David W. Johnson, P.E.
2. Test reports on 1) Uniform Static Air Pressure Test, Loading per FBC TAS 202-94
2) Large Missile Impact Test per FBC, TAS 201-94
3) Cyclic Wind Pressure Loading per FBC, TAS 203-94
4) Forced Entry Test, per FBC, TAS 202-94
5) Tensile Test per ASTM E8
along with marked-up drawings and installation diagram of 9'x 8', 27ga steel garage door Coachman Model CGU11W6 with Lexan polycarbonate windows, prepared by American Test Lab, Inc., Test Report No. **ATLNC 0717.01-14**, dated 08/04/2014, signed and sealed by David W. Johnson, P.E.
2. Test reports on 1) Uniform Static Air Pressure Test, Loading per FBC TAS 202-94
2) Large Missile Impact Test per FBC, TAS 201-94
3) Cyclic Wind Pressure Loading per FBC, TAS 203-94
4) Forced Entry Test, per FBC, TAS 202-94
5) Tensile Test per ASTM E8
along with marked-up drawings and installation diagram of 16'2"x 8', 27ga steel garage door Model GD2LPW8 with MAK SL and/or MAK 15 windows, prepared by American Test Lab, Inc., Test Report No. **ATLNC 1105-01-13**, dated 01/14/2014, signed and sealed by David W. Johnson, P.E.
3. Test report on Salt Spray per ASTM B117 of painted G40 galvanized painted and G90 panels, prepared by Fenestration Testing Laboratory, Inc., Test Report No. **7890**, dated 10/01/2014, signed by Idalmis Ortega, P.E.

C. CALCULATIONS

1. Jamb anchor calculations prepared by Clopay Building Products Company, dated 08/24/2015, signed and sealed by Mark Westerfield, P.E.

D. QUALITY ASSURANCE

1. Miami-Dade Department of Regulatory and Economic Resources (RER)



Carlos M. Utrera, P.E.
Product Control Examiner
NOA No 20-0819.03
Expiration Date: November 25, 2025
Approval Date: October 22, 2020

NOTICE OF ACCEPTANCE: EVIDENCE SUBMITTED

E. MATERIAL CERTIFICATIONS

1. Notice of Acceptance No. **15-0915.08** issued to SABIC Innovative Plastics, US LLC for their Lexan Polycarbonate Sheet Products, approved on 12/10/2015, expiring on 07/17/2018.
2. Notice of Acceptance No. **17-0410.01** issued to Covestro LLC for their Makrolon Polycarbonate Sheets, approved on 06/08/2017, expiring on 08/27/2022.
3. Test report on Surface Burning Characteristics, per ASTM E84 of the polyurethane foam insulation, prepared by QAI Laboratories, Test Report No. **RJ2814-3**, dated 10/14/2013, signed by Greg Banasky.
4. Test report on Ignition Temperature of Plastics of the polyurethane foam insulation per ASTM D1929, prepared by UL LLC, Test Report No. **4786399941/ R5692**, dated 05/20/2014, signed by James Smith.

F. STATEMENTS

1. Statement letter of code conformance to 5th edition (2014) FBC issued by Clopay Building Products Company, dated 08/24/2015, signed and sealed by Mark Westerfield, P.E.
2. Statement letter of no financial interest issued by Clopay Building Products Company, dated 08/24/2015, signed and sealed by Mark Westerfield, P.E.

2. EVIDENCE SUBMITTED UNDER NOA # 17-0809.29

A. DRAWINGS

1. Drawing No. **104948**, titled "Canyon Ridge/Coachman Intellicore W6 Single Car", sheets 1 through 3 of 3, dated 08/24/2015, with revision 2 dated 07/18/2017, prepared by Clopay Building Products Company, signed and sealed by Mark Westerfield, P.E.

B. TESTS

1. None.

C. CALCULATIONS

1. None.

D. QUALITY ASSURANCE

1. Miami-Dade Department of Regulatory and Economic Resources (RER)

E. MATERIAL CERTIFICATIONS

1. None.

F. STATEMENTS

1. Statement letter of code conformance to 2010, 5th Edition (2014) and 6th Edition (2017) FBC issued by Clopay Building Products Company, dated 08/02/2017, signed and sealed by Mark Westerfield, P.E.



Carlos M. Utrera, P.E.
Product Control Examiner
NOA No 20-0819.03
Expiration Date: November 25, 2025
Approval Date: October 22, 2020

NOTICE OF ACCEPTANCE: EVIDENCE SUBMITTED

3. NEW EVIDENCE SUBMITTED

A. DRAWINGS

1. Drawing No. **104948**, titled “Canyon Ridge/Coachman Intellicore W6 Single Car”, sheets 1 through 3 of 3, dated 08/24/2015, with revision 3 dated 08/01/2020, prepared by Clopay Corporation, signed and sealed by Mark Westerfield, P.E.

B. TESTS

1. None.

C. CALCULATIONS

1. None.

D. QUALITY ASSURANCE

1. Miami-Dade Department of Regulatory and Economic Resources (RER)

E. MATERIAL CERTIFICATIONS

1. None.

F. STATEMENTS

1. Statement letter of code conformance to the 6th Edition (2017) and 7th Edition (2020) of the FBC issued by Clopay Corporation, dated 08/17/2020, signed and sealed by Mark Westerfield, P.E.
2. Statement letter of no financial interest issued by Clopay Corporation, dated 08/17/2020, signed and sealed by Mark Westerfield, P.E.
3. Certificate of amendment changing the company name from Clopay Building Products Company, Inc. to Clopay Corporation, issued by the State of Delaware, dated 08/27/2019.



Carlos M. Utrera, P.E.
Product Control Examiner
NOA No 20-0819.03
Expiration Date: November 25, 2025
Approval Date: October 22, 2020

| SHEET: 1 OF 3 | REVISIONS | | | | | |
|------------------|-----------|--------|---------|---------|---|---|
| | REV. NO. | ZONE: | DATE: | ECN NO. | APPVD: | DESCRIPTION |
| | 01 | - | 8/24/15 | - | MW | UPDATED FOR MIAMI-DADE APPLICATION |
| | 02 | - | 7/18/17 | - | SH | UPDATED CODE COMPLIANCE STATEMENT TO ADD 6TH EDITION FBC. |
| 03 | - | 8/1/20 | - | MWW | UPDATED TITLE BLOCK AND COMPLIANCE STATEMENT TO 7TH EDITION | |

CLOPAY CANYON RIDGE SERIES: CAN2nn-XX, COACHMAN SERIES: CGUnn, CXUnn
 HOLMES GLENMOOR SERIES: GLN2nn-XX, SETTLERS SERIES: SXUnn
 IDEAL CARRIAGE HOUSE CUSTOM WOOD-LOOK SERIES: MWL2nn-XX, AFFINITY SERIES AGUnn
MODEL DESIGNATION NOTE 1: "nn" REPRESENTS THE ARRANGEMENT OF THE DECORATIVE OVERLAYS.
 COACHMAN-TYPES DOORS ARE 2-5/8" THICK.
MODEL DESIGNATION NOTE 2: "XX" REPRESENTS THE TYPE OF CLADDING. IF "XX" IS "MN" "PN" "CN" OR "NC" THE DOOR HAS EITHER CLADDING OR OVERLAYS AND IS 2-1/2" THICK OVERALL. ANY OTHER VALUE FOR "XX" INDICATES THAT THE DOOR HAS CLADDING AND OVERLAYS ON THE 2" BASE DOUBLE-SKIN INSULATED DOOR AND IS 3" THICK OVERALL.

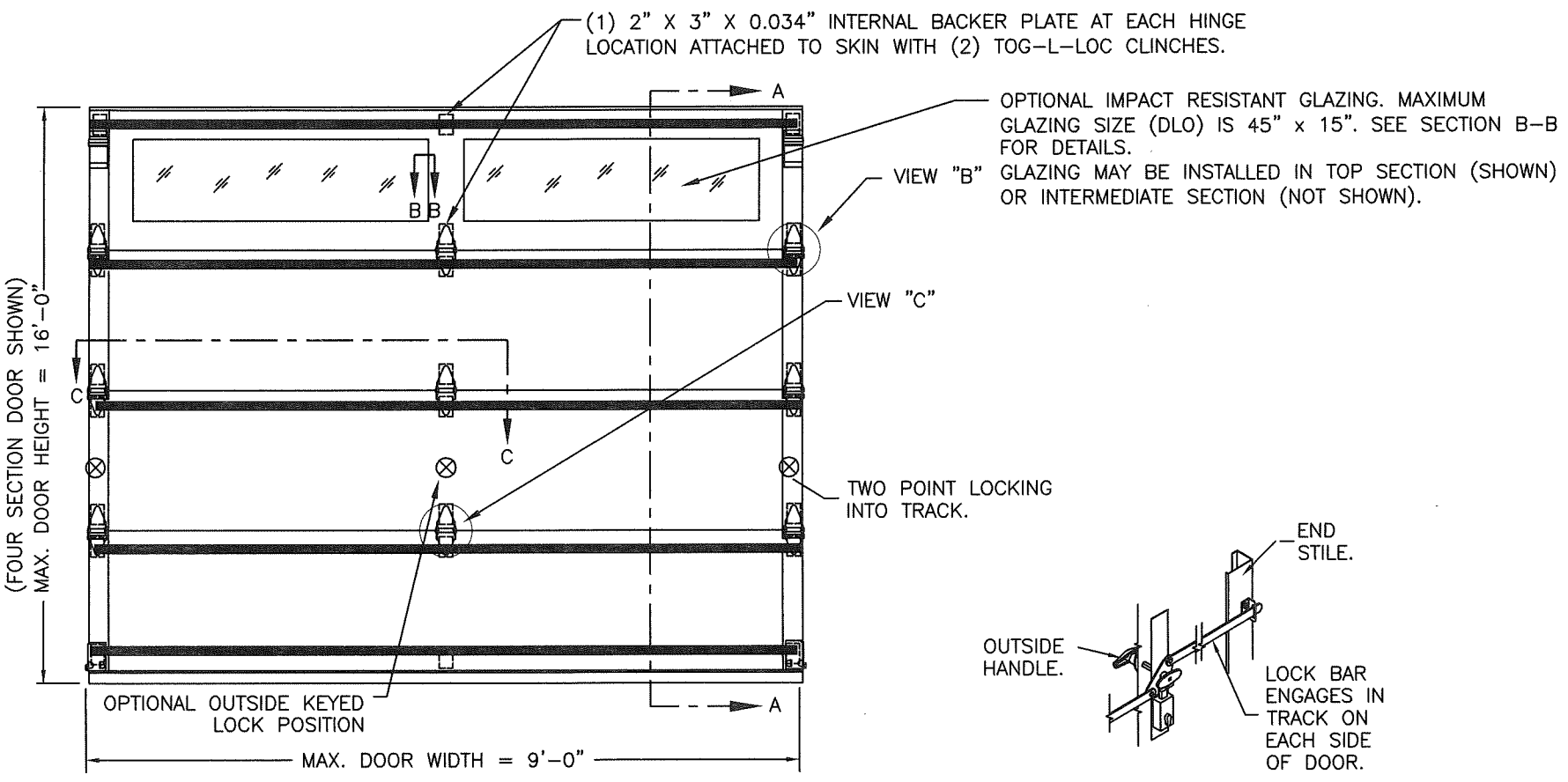

IMPACT-RESISTANT CONSTRUCTION:
 SOLID DOORS (NO GLAZING) OR DOORS WITH OPTIONAL IMPACT-RESISTANT GLAZING ARE IMPACT-RESISTANT. OPTIONAL IMPACT RESISTANT ASSEMBLY CONSISTS OF ALUMINUM FRONT FRAME AND SABIC IP LEXAN 9034 (VERSIONS ALSO APPROVED: MR10, 9030, 90318, 90316, 90317, 90311, 90314, 90355) OR BAYER MAKROLON GP (VERSIONS ALSO APPROVED: SL, AR, 15), APPROVED CC1 PLASTICS IN ACCORDANCE WITH IBC/FBC 2606 AND APPROVED C1 PLASTICS IN ACCORDANCE WITH FBC 2612. THE ENTIRE DOOR ASSEMBLY INSTALLED IN COMPLIANCE WITH THIS SECTION MEETS THE WIND LOAD REQUIREMENTS OF THE FLORIDA BUILDING CODE AND INTERNATIONAL BUILDING CODE AND IS LARGE- AND SMALL-MISSILE IMPACT RESISTANT.

SECTION B-B (IMPACT-RESISTANT GLAZING OPTION)

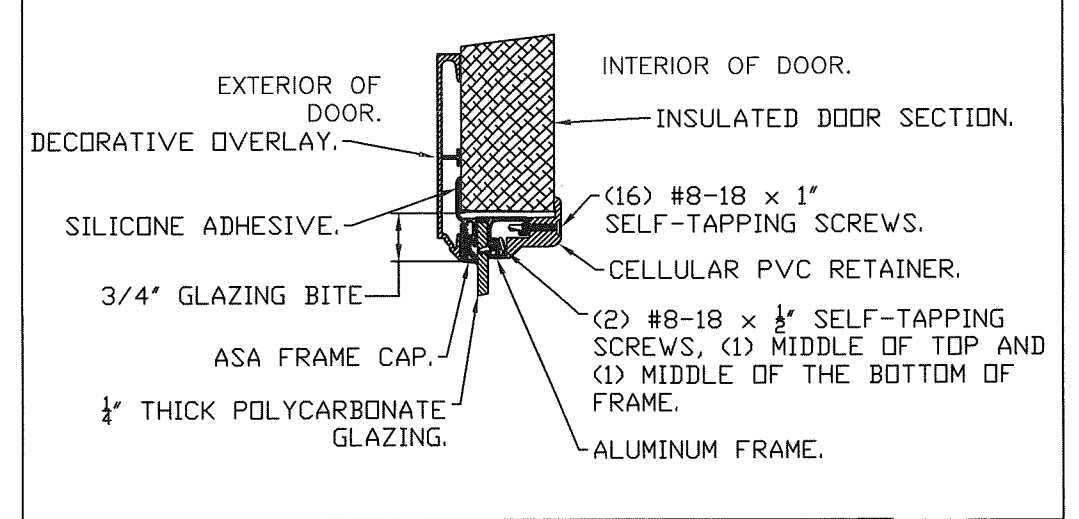

IMPACT-RESISTANT GLAZING DETAILS

| DOOR WIDTH | # OF INTERM. HINGES/JOINT |
|--------------|---------------------------|
| 6'2" TO 7'6" | 2 |
| 7'8" TO 9'0" | 1 |

| DOOR HEIGHT | # OF SECTIONS | # OF U-BARS |
|----------------|---------------|-------------|
| UP TO 6'0" | 3 | 4 |
| 6'3" TO 8'0" | 4 | 5 |
| 8'3" TO 10'0" | 5 | 6 |
| 10'3" TO 12'0" | 6 | 7 |
| 12'3" TO 14'0" | 7 | 8 |
| 14'3" TO 16'0" | 8 | 9 |

MAX SECTION HEIGHT: 24"

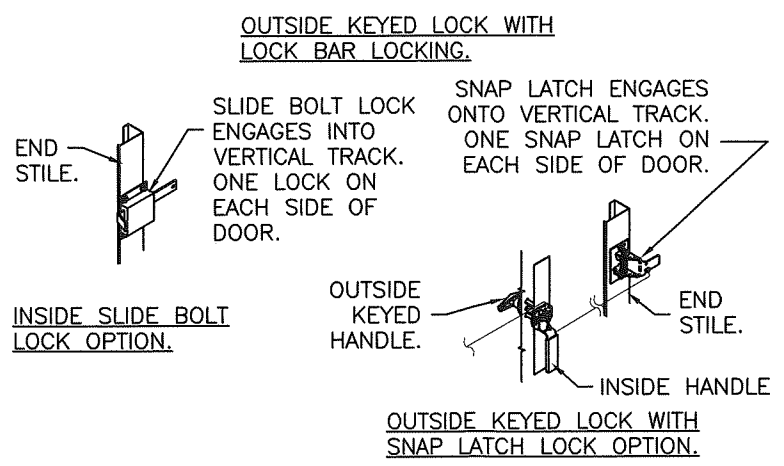

THIS PRODUCT CONFORMS TO THE REQUIREMENTS OF 6TH AND 7TH EDITION OF THE FLORIDA BUILDING CODE

DESIGN LOADS: +38.0 P.S.F. & -44.0 P.S.F.

DESIGN ENGINEER:
 MARK WESTERFIELD, P.E.
 FLORIDA LICENSE No. 48495

PRODUCT REVISED
 as complying with the Florida Building Code
 NOA-No. 20-0819.03
 Expiration Date 11/25/2025
 By *[Signature]*
 Miami-Dade Product Control

Unless Stated Otherwise TOLERANCES are
 .0 = ±.031
 .00 = ±.015
 .000 = ±.005
 .0000 = ±.001
 Degrees = ±1/2'

Clopay CORPORATION
 8585 Duke Boulevard
 Mason, OH 45040 USA
 Tel. No. 513-770-4800
 Fax No. 513-770-4853

| | |
|--|---------------|
| MANUFACTURING PRODUCT CODE COACHMAN: DSIUD-1M479 CANYON RIDGE: DSIUD-1K479 | PART NO.: N/A |
| WINDLOAD RATING W6 DP38 | |
| DESCRIPTION: CANYON RIDGE/COACHMAN INTELICORE W6 SINGLE CAR | |
| DRAWN BY: SH | DATE: 7/17/14 |
| CHECKED BY: MW | DATE: 8/24/15 |
| DWG. NO.: 104948 | VER: M-D |

SCALE: NTS
 SHEET 1 OF 3
 DWG. SIZE **B**

CLOPAY CANYON RIDGE SERIES: CAN2nn-XX, COACHMAN SERIES: CGUnn, CXUnn
 HOLMES GLENMOOR SERIES: GLN2nn-XX, SETTLERS SERIES: SXUnn
 IDEAL CARRIAGE HOUSE CUSTOM WOOD-LOOK SERIES: MWL2nn-XX, AFFINITY SERIES AGUnn
 MODEL DESIGNATION NOTE 1: "nn" REPRESENTS THE ARRANGEMENT OF THE DECORATIVE OVERLAYS.
 COACHMAN-TYPES DOORS ARE 2-5/8" THICK.
 MODEL DESIGNATION NOTE 2: "XX" REPRESENTS THE TYPE OF CLADDING. IF "XX" IS "MN" "PN" "CN" OR "NC" THE DOOR HAS EITHER CLADDING OR OVERLAYS AND IS 2-1/2" THICK OVERALL. ANY OTHER VALUE FOR "XX" INDICATES THAT THE DOOR HAS CLADDING AND OVERLAYS ON THE 2" BASE DOUBLE-SKIN INSULATED DOOR AND IS 3" THICK OVERALL.

SHEET:
2 OF 3

| REVISIONS | | | | | DESCRIPTION |
|-----------|------|------|---------|--------|------------------------------------|
| REV. NO. | ZONE | DATE | ECN NO. | APPVD: | |
| 03 | - | - | - | - | SEE REVISION HISTORY ON SHEET ONE. |

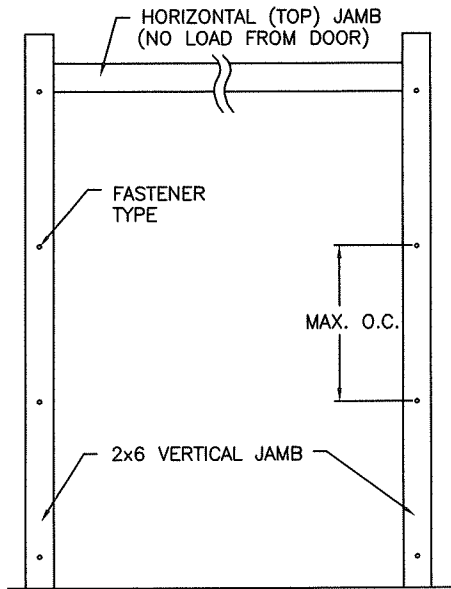

JAMB TO SUPPORTING STRUCTURE ATTACHMENT

- NOTES:
1. ALL THE LOAD FROM THE DOOR IS TRANSFERRED TO THE TRACK AND THEN FROM THE TRACK TO THE 2x6 VERTICAL SYP (GRADE #2 OR BETTER) JAMBS. NO LOAD FROM THE DOOR IS TRANSFERRED TO THE HORIZONTAL (TOP) JAMB.
 2. EACH VERTICAL JAMB SEES A MAXIMUM DESIGN LOAD OF +171 LB & -198 LB. PER LINEAR FOOT OF JAMB.
 3. ALL JAMB FASTENERS MAY BE (BUT ARE NOT REQUIRED TO BE) COUNTERSUNK TO PROVIDE A FLUSH MOUNTING SURFACE.
 4. A 1/3 STRESS INCREASE FOR WIND LOAD WAS NOT USED IN THE CALCULATION OF ALLOWABLE LOADS FOR ANCHORS AND FASTENERS FOR STEEL, CONCRETE AND MASONRY.

PREPARATION OF JAMBS BY OTHERS

NOTE: THE DESIGN OF THE SUPPORTING STRUCTURAL ELEMENTS SHALL BE THE RESPONSIBILITY OF THE PROFESSIONAL OF RECORD FOR THE BUILDING OR STRUCTURE AND IN ACCORDANCE WITH CURRENT BUILDING CODES FOR THE LOADS LISTED ON THIS DRAWING.

2x6 JAMB TO SUPPORTING STRUCTURE ATTACHMENT
(NOT TO BE USED FOR ATTACHMENT OF TRACK ANGLE TO 2x6 VERTICAL JAMBS OR SUPPORTING STRUCTURE)

| BUILDING TYPE | FASTENER TYPE | MAXIMUM ON-CENTER DISTANCE BETWEEN FASTENERS* | STEEL WASHERS REQUIRED |
|--------------------------|--|---|------------------------|
| HOLLOW CMU BLOCK WALL | 1/4" x 1-1/4" MIN. EMBED ULTRACON CONCRETE ANCHOR | 9-3/4" | 1" O.D. |
| GROUT-FILLED CMU BLOCK | 1/4" x 1-3/4" MIN. EMBED ULTRACON CONCRETE ANCHOR | 16" | 1" O.D. |
| 2000 PSI MIN. CONCRETE | 1/4" x 1-3/4" MIN. EMBED ULTRACON CONCRETE ANCHOR | 24" | 1" O.D. |
| 2000 PSI MIN. CONCRETE | 1/4" x 1-3/4" MIN. EMBED TAPCON CONCRETE ANCHOR | 24" | 1" O.D. |
| 2000 PSI MIN. CONCRETE | 3/8" x 1-3/4" MIN. EMBED WEJ-IT ANKR TITE SLEEVE ANCHOR | 24" | INCLUDED |
| 4000 PSI MIN. CONCRETE | 3/8" x 1-3/4" MIN. EMBED WEJ-IT ANKR TITE SLEEVE ANCHOR | 24" | INCLUDED |
| WOOD FRAME (SYP 0.55 SG) | 1/2" x 3" LAG SCREW (ASTM A307, GRADE A) 1-5/8" EMBED INTO STRUCTURE | 24" | 1" O.D. |

* FIRST (BOTTOM) ANCHOR STARTING AT NO MORE THAN HALF OF THE MAXIMUM ON-CENTER DISTANCE. HIGHEST ANCHOR INSTALLED AT LEAST AS HIGH AS THE DOOR OPENING.
 CLOPAY DOES NOT SUPPLY JAMB ATTACHMENT FASTENERS.
 MINIMUM DISTANCE BETWEEN CENTER OF ANCHOR AND EDGE OF CONCRETE BLOCK: 2-1/2", EXCLUDING STUCCO THICKNESS.

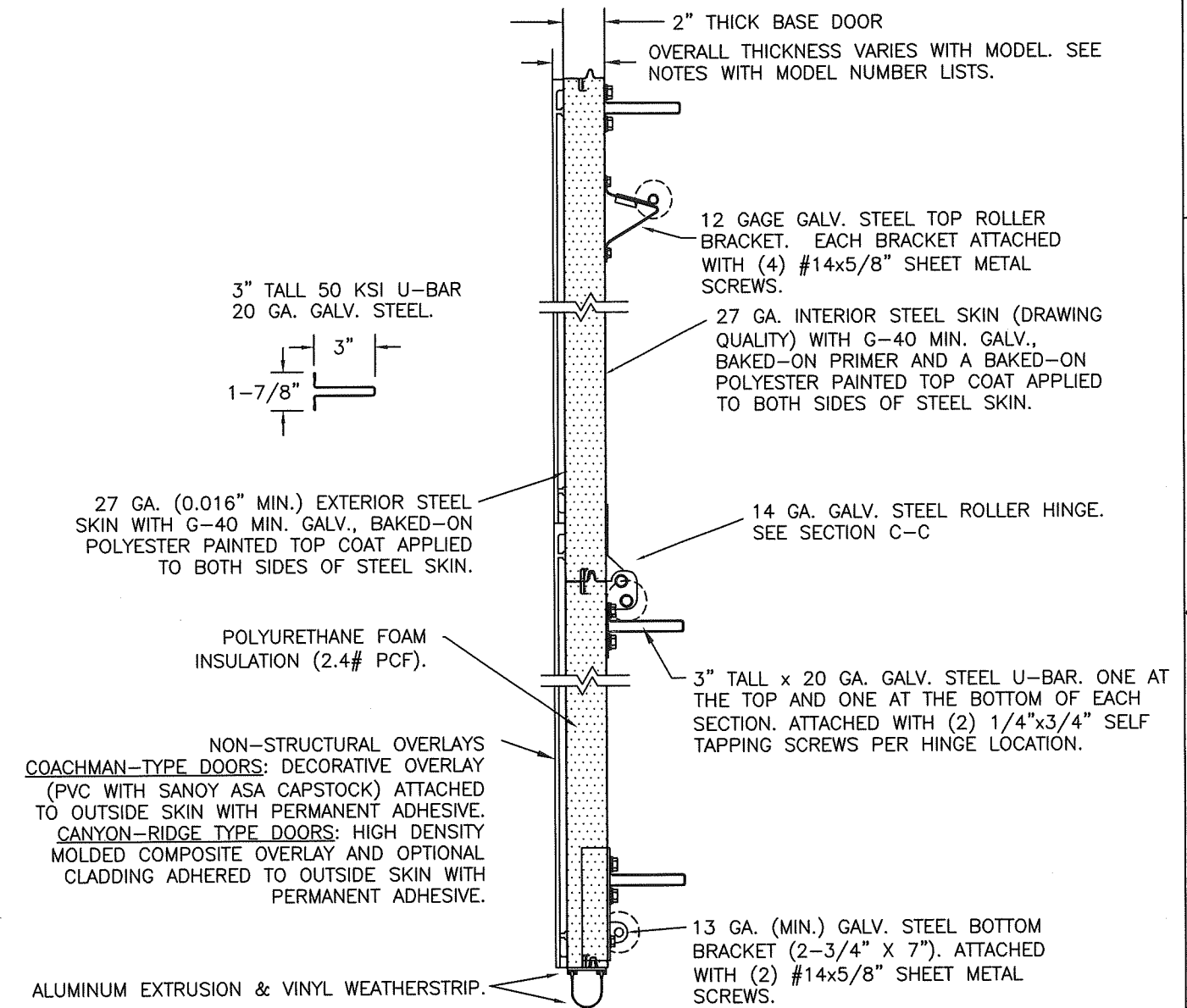

SECTION A-A (SIDE VIEW)

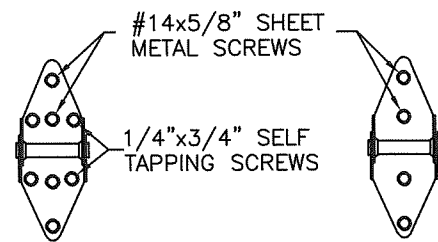

14 GA. END HINGES VIEW "B" 14 GA. INTERMEDIATE HINGE VIEW "C"

DESIGN ENGINEER:
 MARK WESTERFIELD, P.E.
 FLORIDA LICENSE NO. 48495

PRODUCT REVISED
 as complying with the Florida Building Code
 NOA-No. 20-0819.03
 Expiration Date 11/25/2025
 By *[Signature]*
 Miami-Dade Product Control

DESIGN LOADS: +38.0 P.S.F. & -44.0 P.S.F.

Unless Stated Otherwise TOLERANCES are
 .0 = ±.031
 .00 = ±.015
 .000 = ±.005
 .0000 = ±.001
 Degrees = ±1/2'

Clopay CORPORATION
 8585 Duke Boulevard
 Mason, OH 45040 USA
 Tel. No. 513-770-4800
 Fax No. 513-770-4853

MANUFACTURING PRODUCT CODE
 COACHMAN: DSIUD-1M479
 CANYON RIDGE: DSIUD-1K479

PART NO.: N/A

WINDLOAD RATING
W6 DP38

DESCRIPTION: CANYON RIDGE/COACHMAN INTELICORE W6 SINGLE CAR
 DRAWN BY: SH DATE: 7/17/14 SCALE: NTS DWG. B
 CHECKED BY: MW DATE: 8/24/15 SHEET 2 OF 3
 DWG. NO.: 104948 VER: M-D

CLOPAY CANYON RIDGE SERIES: CAN2nn-XX, COACHMAN SERIES: CGUnn, CXUnn
 HOLMES GLENMOOR SERIES: GLN2nn-XX, SETTLERS SERIES: SXUnn
 IDEAL CARRIAGE HOUSE CUSTOM WOOD-LOOK SERIES: MWL2nn-XX, AFFINITY SERIES AGUnn
 MODEL DESIGNATION NOTE 1: "nn" REPRESENTS THE ARRANGEMENT OF THE DECORATIVE OVERLAYS.
 COACHMAN-TYPES DOORS ARE 2-5/8" THICK.
 MODEL DESIGNATION NOTE 2: "XX" REPRESENTS THE TYPE OF CLADDING. IF "XX" IS "MN" "PN" "CN" OR "NC" THE DOOR HAS EITHER CLADDING OR OVERLAYS AND IS 2-1/2" THICK OVERALL. ANY OTHER VALUE FOR "XX" INDICATES THAT THE DOOR HAS CLADDING AND OVERLAYS ON THE 2" BASE DOUBLE-SKIN INSULATED DOOR AND IS 3" THICK OVERALL.

SHEET:
3 OF 3

| REVISIONS | | | | | |
|-----------|-------|-------|---------|--------|------------------------------------|
| REV. NO. | ZONE: | DATE: | ECN NO. | APPVD: | DESCRIPTION |
| 03 | - | - | - | - | SEE REVISION HISTORY ON SHEET ONE. |

2" TRACK CONFIGURATION.

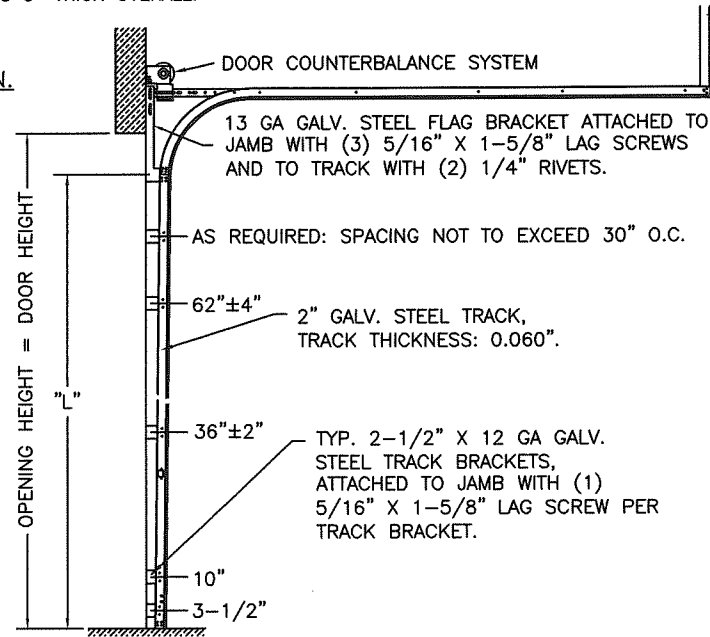

| DOOR HEIGHT | "L" |
|-------------|------|
| 6'-6" | 70" |
| 7'-0" | 76" |
| 7'-6" | 82" |
| 8'-0" | 88" |
| 8'-6" | 94" |
| 9'-0" | 100" |
| 9'-6" | 106" |
| 10'-0" | 112" |
| 10'-6" | 118" |
| 11'-0" | 124" |
| 11'-6" | 130" |
| 12'-0" | 136" |
| 12'-6" | 142" |
| 13'-0" | 148" |
| 13'-6" | 154" |
| 14'-0" | 160" |
| 14'-6" | 166" |
| 15'-0" | 172" |
| 15'-6" | 178" |
| 16'-0" | 184" |

HORIZONTAL TRACK SUPPORT BY DOOR INSTALLER (TO SUIT).

JAMB CONFIGURATION.

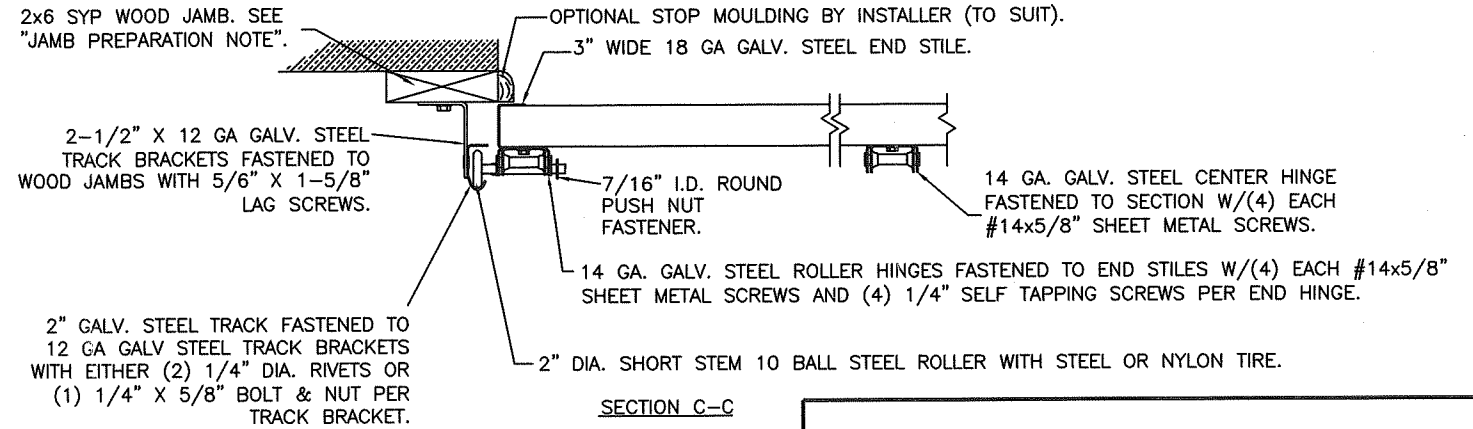

NOTE: TRACK CONFIGURATION ABOVE THE DOOR OPENING DOES NOT AFFECT THE WIND LOAD RATING OF THIS DOOR.

3" TRACK IS ALSO AVAILABLE.

PREPARATION OF JAMBS BY OTHERS.

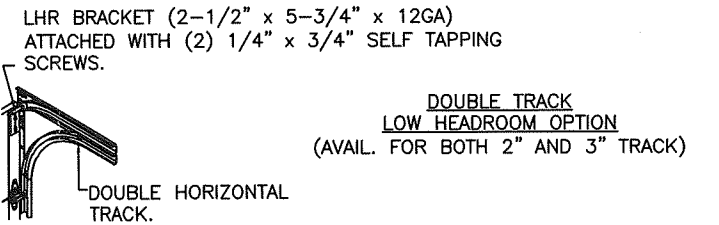

PRODUCT REVISED
as complying with the Florida Building Code

NOA-No. 20-0819.03

Expiration Date 11/25/2025

By *[Signature]*
Miami-Dade Product Control

DESIGN LOADS: +38.0 P.S.F. & -44.0 P.S.F.

Unless Stated Otherwise TOLERANCES are

| | |
|---------|---------|
| .0 | = ±.031 |
| .00 | = ±.015 |
| .000 | = ±.005 |
| .0000 | = ±.001 |
| Degrees | = ±1/2' |

Unless Stated Otherwise DIMENSIONS ARE IN INCHES.



8585 Duke Boulevard
Mason, OH 45040 USA
Tel. No. 513-770-4800
Fax No. 513-770-4853

MANUFACTURING PRODUCT CODE
COACHMAN: DSIUD-1M479
CANYON RIDGE: DSIUD-1K479

PART NO.: N/A

WINDLOAD RATING
W6 DP38

| | |
|------------------------------------|---------------------------|
| DESCRIPTION: CANYON RIDGE/COACHMAN | INTELLICORE W6 SINGLE CAR |
| DRAWN BY: SH | DATE: 7/17/14 |
| CHECKED BY: MW | DATE: 8/24/15 |
| DWG. NO.: 104948 | VER: M-D |

DESIGN ENGINEER:
MARK WESTERFIELD, P.E.
FLORIDA LICENSE No. 48495