



**MIAMI-DADE COUNTY  
PRODUCT CONTROL SECTION**

11805 SW 26 Street, Room 208  
Miami, Florida 33175-2474  
T (786) 315-2590 F (786) 315-2599

**DEPARTMENT OF REGULATORY AND ECONOMIC RESOURCES (RER)  
BOARD AND CODE ADMINISTRATION DIVISION**

[www.miamidade.gov/economy](http://www.miamidade.gov/economy)

**NOTICE OF ACCEPTANCE (NOA)**

**Clopay Corporation  
8585 Duke Boulevard  
Mason, OH 45040**

**SCOPE:** This NOA is being issued under the applicable rules and regulations governing the use of construction materials. The documentation submitted has been reviewed and accepted by Miami-Dade County RER-Product Control Section to be used in Miami-Dade County and other areas where allowed by the Authority Having Jurisdiction (AHJ).

This NOA shall not be valid after the expiration date stated below. The Miami-Dade County Product Control Section (In Miami-Dade County) and/or the AHJ (in areas other than Miami-Dade County) reserve the right to have this product or material tested for quality assurance purposes. If this product or material fails to perform in the accepted manner, the manufacturer will incur the expense of such testing and the AHJ may immediately revoke, modify, or suspend the use of such product or material within their jurisdiction. RER reserves the right to revoke this acceptance, if it is determined by Miami-Dade County Product Control Section that this product or material fails to meet the requirements of the applicable building code.

This product is approved as described herein and has been designed to comply with the Florida Building Code, including the High Velocity Hurricane Zone.

**DESCRIPTION: Single Car W8 Steel Pan Sectional Garage Door up to 9ft-0in Wide w/ Impact Resistant Lites (DP +48.0, -54.0 PSF)**

**APPROVAL DOCUMENT:** Drawing No. **103547**, titled "Single Car W8 Pan Door with Impact Resistant Lites", sheet 1 of 1, dated 10/23/2006, with revision **06** dated 08/26/2020, prepared by Clopay Corporation, dated 09/20/2020, signed and sealed by Scott Hamilton, P.E., bearing the Miami-Dade County Product Control revision stamp with the Notice of Acceptance number and expiration date by the Miami-Dade County Product Control Section.

**MISSILE IMPACT RATING: Large and Small Missile Impact Resistant**

**LABELING:** A permanent label with the manufacturer's name or logo, manufacturing address, model number, the positive and negative design pressure rating, indicate impact rated if applicable, installation instruction drawing reference number, approval number (NOA), the applicable test standards, and the statement reading 'Miami-Dade County Product Control Approved' is to be located on the door's side track, bottom angle, or inner surface of a panel.

**RENEWAL** of this NOA shall be considered after a renewal application has been filed and there has been no change in the applicable building code negatively affecting the performance of this product.

**TERMINATION** of this NOA will occur after the expiration date or if there has been a revision or change in the materials, use, and/or manufacture of the product or process. Misuse of this NOA as an endorsement of any product, for sales, advertising or any other purposes shall automatically terminate this NOA. Failure to comply with any section of this NOA shall be cause for termination and removal of NOA.

**LIMITATION:** This approval requires the manufacturer to test all coils used to fabricate door panels under this Notice of Acceptance. A minimum of 2 specimens shall be cut from each coil and tensile tested according to ASTM E-8 by a Miami Dade County approved laboratory selected and paid by the manufacturer. Every 3 months, four times a year, the manufacturer shall mail to this office: a copy of the test reports with confirmation that the specimen were selected from coils at the manufacturer production facilities and a notarized statement from the manufacturer that only coils with yield strength of 30,600 psi or more shall be used to make door panels under this NOA.

**ADVERTISEMENT:** The NOA number preceded by the words Miami-Dade County, Florida, and followed by the expiration date may be displayed in advertising literature. If any portion of the NOA is displayed, then it shall be done in its entirety.

**INSPECTION:** A copy of this entire NOA shall be provided to the user by the manufacturer or its distributors and shall be available for inspection at the job site at the request of the Building Official.

This NOA revises NOA # **17-1016.27** and consists of this page 1 and evidence pages E-1, E-2 and E-3, as well as approval document mentioned above.

The submitted documentation was reviewed by **Carlos M. Utrera, P.E.**



**NOA No 20-0922.21  
Expiration Date: February 21, 2022  
Approval Date: November 05, 2020**

**NOTICE OF ACCEPTANCE: EVIDENCE SUBMITTED**

**1. Evidence submitted under previous NOA's**

**A. DRAWINGS**

1. Drawing No. **103547**, titled "Single Car W8 Pan Door with Impact Resistant Lites", dated 10/23/2006, with last revision 04 dated 02/2015, sheet 1 of 1, prepared by Clopay Building Products Company, signed and sealed by Scott Hamilton, P.E.

**B. TESTS "*Submitted under NOA # 06-1107.02*"**

1. Test reports on 1) Uniform Static Air Pressure Test, Loading per FBC, TAS 202  
2) Large Missile Impact Test per FBC, TAS 201  
3) Cyclic Wind Pressure Loading per FBC, TAS 203  
along with marked-up drawings and installation diagram of Clopay 9'x 8' 24 ga. Steel Door, Model 94W8, prepared by American Testing Lab, Inc., Test Report No. **ATLNC 1008.01-07**, dated 11/05/2007, signed and sealed by David W. Johnson, P.E.

***"Submitted under NOA # 06-1107.02"***

2. Test report on Accelerated Weathering Using Xenon Arc Light Apparatus, per ASTM G155, Test Report No. **HETI-06-A002**, prepared by Hurricane Engineering and Testing, Inc, dated 11/08/2006, signed and sealed by Rafael E. Droz-Seda, P.E.
3. Tensile Test on GE Lexan SLX2432T, per ASTM D 638 and ASTM E 8, Test Reports No. **HETI-06-T566** and **HETI-06-T634**, prepared by Hurricane Engineering and Testing, Inc., dated 07/14/2006 and 11/08/2006, signed and sealed by Rafael E. Droz-Seda, P.E.
4. Test report on Self-Ignition Temperature (ASTM D 1929), Rate of Burn (ASTM D 635) and Smoke Density (ASTM D 2843), Test Report No. **ETC-06-1024-17496.0**, dated 05/26/2006, signed and sealed by Joseph L. Doldan, P.E.

**C. CALCULATIONS "*Submitted under NOA # 06-1107.02*"**

1. Anchoring calculations prepared by Clopay Building Products Company, dated 10/24/2006, signed and sealed by Scott Hamilton, P.E.

**D. QUALITY ASSURANCE**

1. Miami-Dade Department of Regulatory and Economic Resources (RER)

**E. MATERIAL CERTIFICATIONS "*Submitted under NOA # 06-1107.02*"**

1. Tensile tests on Painted Embossed Steel, per ASTM E 8, Test Reports No. **HETI-06-T596**, **T597** and **T598**, dated 08/24/2006, signed by Rafael E. Droz-Seda, P.E.
2. Salt Spray Exposure Test Report No. **30160-04-63365**, prepared by Stork Twin City Testing Corporation, dated 01/26/2005, signed by John D. Lee, P.E.



---

**Carlos M. Utrera, P.E.**  
**Product Control Examiner**  
**NOA-No. 20-0922.21**  
**Expiration Date: February 21, 2022**  
**Approval Date: November 05, 2020**

**NOTICE OF ACCEPTANCE: EVIDENCE SUBMITTED**

**F. STATEMENTS**

1. Statement letters of code conformance to the 5<sup>th</sup> edition (2014) FBC and of no financial interest, both issued by Clopay Building Products Company, dated 12/06/2016, signed and sealed by Scott Hamilton, P.E.

*“Submitted under NOA # 15-0225.03”*

2. Statement letter of code conformance with the 2010 and the 5<sup>th</sup> edition (2014) FBC issued by Clopay Building Products Company, dated 02/18/2015, signed and sealed by Scott Hamilton, P.E.

*“Submitted under NOA # 12-0105.01”*

3. Statement letter of no financial interest issued by Clopay Building Products Company, dated 01/04/2012, signed and sealed by Scott Hamilton, P.E.

**2. Evidence submitted under previous NOA # 17-1016.27**

**A. DRAWINGS**

1. Drawing No. **103547**, titled “Single Car W8 Pan Door with Impact Resistant Lites”, dated 10/23/2006, with last revision 04 dated 02/2015, sheet 1 of 1, prepared by Clopay Building Products Company, signed and sealed by Scott Hamilton, P.E.

**B. TESTS**

1. None.

**C. CALCULATIONS**

1. None.

**D. QUALITY ASSURANCE**

1. Miami-Dade Department of Regulatory and Economic Resources (RER)

**E. MATERIAL CERTIFICATIONS**

1. None.

**F. STATEMENTS**

1. Statement letter of code conformance to the 6<sup>th</sup> edition (2017) FBC issued by Clopay Building Products Company, dated 10/04/2017, signed and sealed by Scott Hamilton, P.E.



---

**Carlos M. Utrera, P.E.**  
**Product Control Examiner**  
**NOA-No. 20-0922.21**

**Expiration Date: February 21, 2022**  
**Approval Date: November 05, 2020**

**NOTICE OF ACCEPTANCE: EVIDENCE SUBMITTED**

**3. New evidence submitted**

**A. DRAWINGS**

1. Drawing No. **103547**, titled “Single Car W8 Pan Door with Impact Resistant Lites”, dated 10/23/2006, with last revision **06** dated 08/26/2020, sheet 1 of 1, prepared by Clopay Corporation, dated 09/20/2020, signed and sealed by Scott Hamilton, P.E.

**B. TESTS**

1. None.

**C. CALCULATIONS**

1. None.

**D. QUALITY ASSURANCE**

1. Miami-Dade Department of Regulatory and Economic Resources (RER)

**E. MATERIAL CERTIFICATIONS “Submitted under NOA #17-1016.27”**

1. Notice of Acceptance No. **15-0915.08** issued to SABIC Innovative Plastics US, LLC for their Lexan Polycarbonate Sheet Products, approved on 12/10/2015, expiring on 07/17/2018.

**F. STATEMENTS**

1. Statement letters of code conformance to **6<sup>th</sup> Edition (2017) and 7<sup>th</sup> Edition (2020) FBC**, issued by Clopay Corporation, dated 09/15/2020, signed and sealed by Scott Hamilton, P.E.
2. Certificate of amendment changing the company name from Clopay Building Products Company, Inc. to Clopay Corporation, issued by the State of Delaware, dated 08/27/2019.



---

**Carlos M. Utrera, P.E.**  
**Product Control Examiner**  
**NOA-No. 20-0922.21**  
**Expiration Date: February 21, 2022**  
**Approval Date: November 05, 2020**



CLOPAY MODELS 84A, 94, 98, H94  
 IDEAL MODELS: 4RST, H4ST, 4F  
 HOLMES MODELS: 48, 48B

END STILES ATTACHED TO DOOR SKIN WITH PATENTED TOG-L-LOC SYSTEM. END STILES HAVE (2) TOG-L-LOC CLINCHES AT TOP AND (2) AT BOTTOM. ALONG THE FRONT FACE:  
 • 21" SECTIONS HAVE (6) TOG-L-LOC CLINCHES;  
 • 18" SECTIONS HAVE (4) TOG-L-LOC CLINCHES.

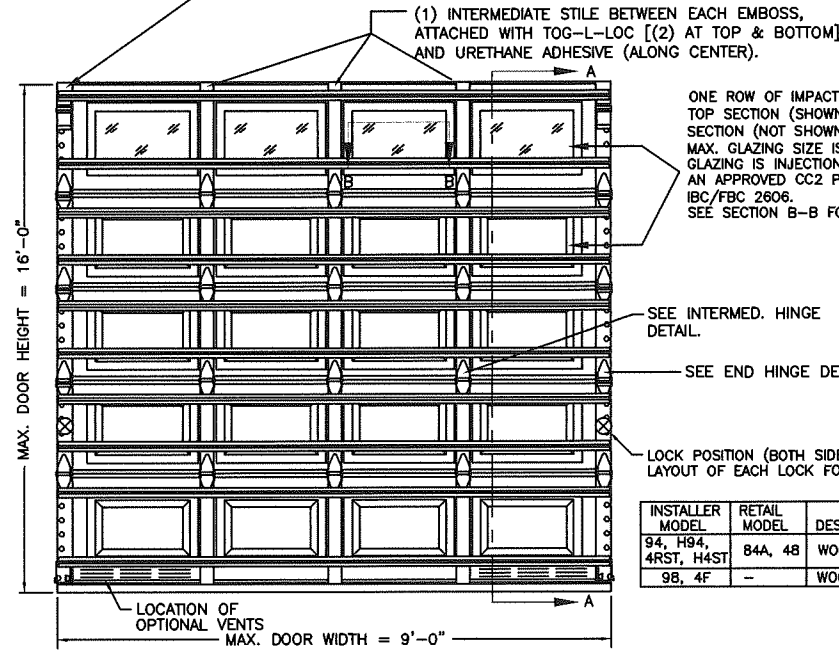

ONE ROW OF IMPACT-RESISTANT GLAZING IN EITHER TOP SECTION (SHOWN) OR NEXT-TO-THE-TOP SECTION (NOT SHOWN). MAX. GLAZING SIZE IS 18-1/2" x 11". GLAZING IS INJECTION MOLDED GE LEXAN SLX2432T, AN APPROVED CC2 PLASTIC IN ACCORDANCE WITH IBC/FBC 2606. SEE SECTION B-B FOR ASSEMBLY DETAILS.

SEE INTERMED. HINGE DETAIL.  
 SEE END HINGE DETAIL.

LOCK POSITION (BOTH SIDES). SEE LAYOUT OF EACH LOCK FOR DETAILS.

INSTALLER MODEL	RETAIL MODEL	DESCRIPTION
94, H94, 4RST, H4ST	84A, 48	WOODGRAIN TEXTURE, RAISED PANEL, GALV. INTER. STILES
98, 4F	-	WOODGRAIN TEXTURE, FLUSH PANEL, GALV. INTER. STILES

SECTION B-B

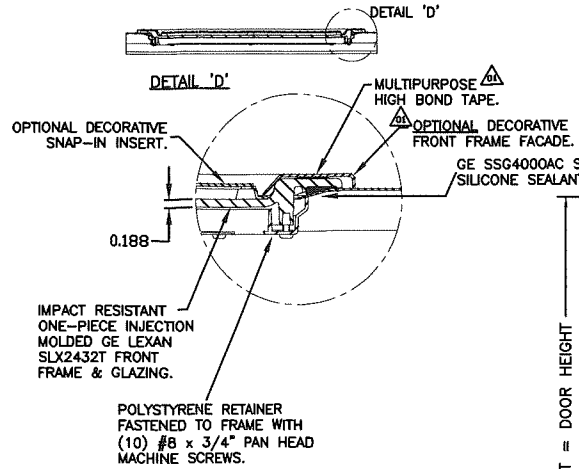

DOOR HEIGHT	NUMBER OF SECTIONS *
6'0" TO 7'0"	4
7'6" TO 8'0"	5
9'0" TO 10'6"	6
10'9" TO 12'3"	7
12'6" TO 14'0"	8
14'3" TO 15'9"	9
16'0"	10

\* SECTIONS ARE EITHER 18" OR 21"

THIS DOOR MEETS THE REQUIREMENTS OF THE LARGE MISSILE IMPACT AND CYCLIC TESTING.

THIS PRODUCT CONFORMS TO THE REQUIREMENTS OF 6TH AND 7TH EDITION OF THE FLORIDA BUILDING CODE

REV	DATE	DESCRIPTION
03	12/15/11	INCREASED MAX. HT.
04	2/2015	ADDED CODE COMPLIANCE STATEMENT.
05	07/18/17	UPDATED CODE COMPLIANCE STATEMENT TO ADD 6TH ED.
06	8/26/20	UPDATED TITLE BLOCK AND COMPLIANCE STATEMENT TO 7TH.

TRACK CONFIGURATION

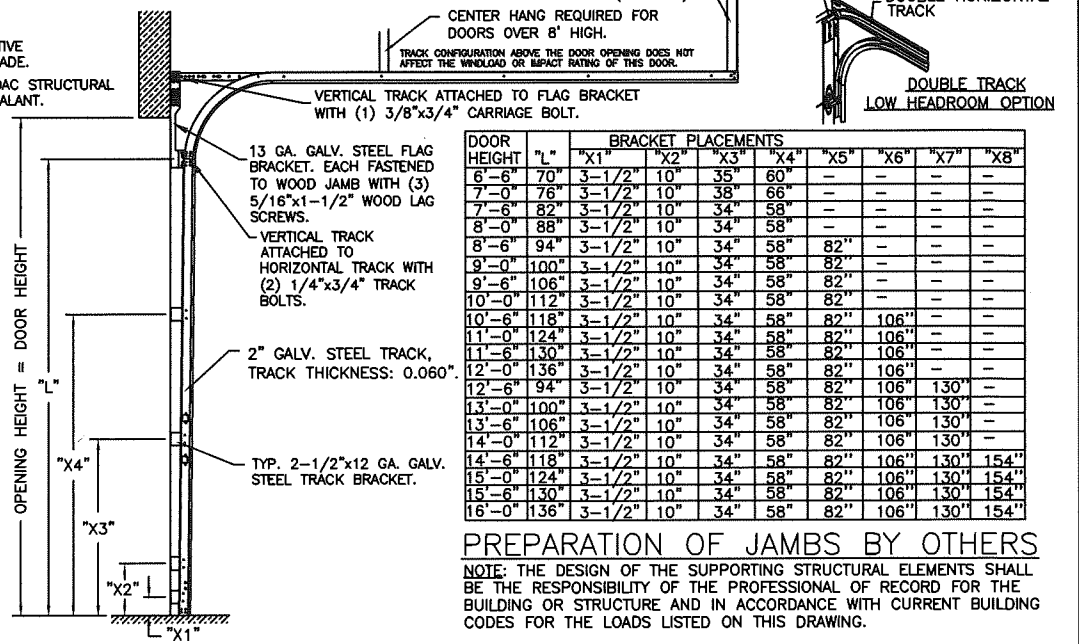

DOOR HEIGHT	BRACKET PLACEMENTS								
	"L"	"X1"	"X2"	"X3"	"X4"	"X5"	"X6"	"X7"	"X8"
6'-6"	70"	3'-1/2"	10"	35"	60"	-	-	-	-
7'-0"	76"	3'-1/2"	10"	38"	66"	-	-	-	-
7'-6"	82"	3'-1/2"	10"	34"	58"	-	-	-	-
8'-0"	88"	3'-1/2"	10"	34"	58"	-	-	-	-
8'-6"	94"	3'-1/2"	10"	34"	58"	82"	-	-	-
9'-0"	100"	3'-1/2"	10"	34"	58"	82"	-	-	-
9'-6"	106"	3'-1/2"	10"	34"	58"	82"	-	-	-
10'-0"	112"	3'-1/2"	10"	34"	58"	82"	-	-	-
10'-6"	118"	3'-1/2"	10"	34"	58"	82"	106"	-	-
11'-0"	124"	3'-1/2"	10"	34"	58"	82"	106"	-	-
11'-6"	130"	3'-1/2"	10"	34"	58"	82"	106"	-	-
12'-0"	136"	3'-1/2"	10"	34"	58"	82"	106"	130"	-
12'-6"	142"	3'-1/2"	10"	34"	58"	82"	106"	130"	-
13'-0"	148"	3'-1/2"	10"	34"	58"	82"	106"	130"	-
13'-6"	154"	3'-1/2"	10"	34"	58"	82"	106"	130"	-
14'-0"	160"	3'-1/2"	10"	34"	58"	82"	106"	130"	-
14'-6"	166"	3'-1/2"	10"	34"	58"	82"	106"	130"	154"
15'-0"	172"	3'-1/2"	10"	34"	58"	82"	106"	130"	154"
15'-6"	178"	3'-1/2"	10"	34"	58"	82"	106"	130"	154"
16'-0"	184"	3'-1/2"	10"	34"	58"	82"	106"	130"	154"

PREPARATION OF JAMBS BY OTHERS  
 NOTE: THE DESIGN OF THE SUPPORTING STRUCTURAL ELEMENTS SHALL BE THE RESPONSIBILITY OF THE PROFESSIONAL OF RECORD FOR THE BUILDING OR STRUCTURE AND IN ACCORDANCE WITH CURRENT BUILDING CODES FOR THE LOADS LISTED ON THIS DRAWING.

INSIDE ELEVATION

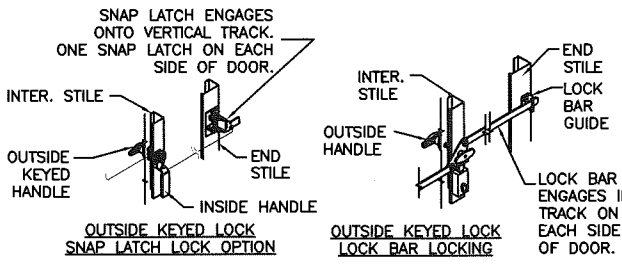

24 GA. (0.0239" MIN. THICK) DDS STEEL EXTERIOR SKIN WITH G-40 GALVANIZING, BAKED-ON PRIMER AND A BAKED-ON POLYESTER PAINTED TOP COAT APPLIED TO BOTH SIDES OF STEEL SKIN. (ASTM No. A653).

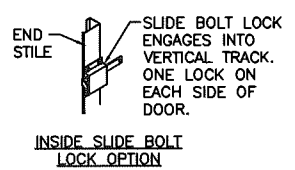

SECTION A-A

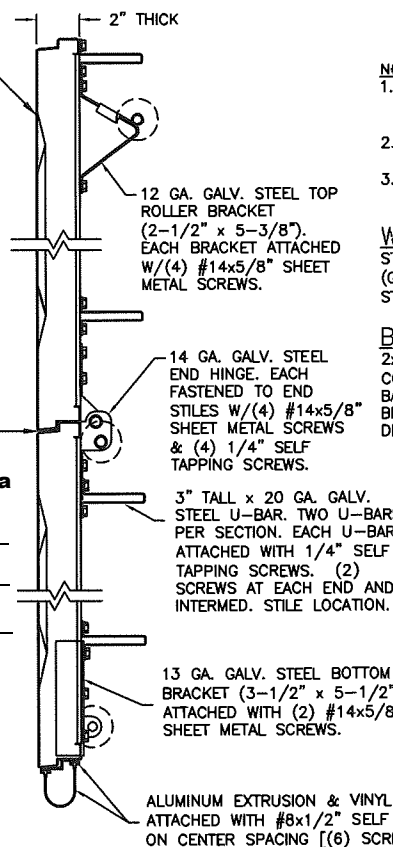

SHIP LAP JOINTS.  
**PRODUCT REVISED**  
 as complying with the Florida Building Code  
 NOA-No. 20-0922.21  
 Expiration Date 02/21/2022  
 By *[Signature]*  
 Miami-Dade Product Control

JAMB TO SUPPORTING STRUCTURE ATTACHMENT

- NOTES:
- ALL THE LOAD FROM THE DOOR IS TRANSFERRED TO THE TRACK AND THEN FROM THE TRACK TO THE 2x6 VERTICAL JAMB (GRADE #2 OR BETTER) JAMBS. NO LOAD FROM THE DOOR IS TRANSFERRED TO THE HORIZONTAL (TOP) JAMB.
  - ALL JAMB FASTENERS MAY BE (BUT ARE NOT REQUIRED TO BE) COUNTERSUNK TO PROVIDE A FLUSH MOUNTING SURFACE.
  - A 1/3 STRESS INCREASE FOR WIND LOAD WAS NOT USED IN THE CALCULATION OF ALLOWABLE LOADS FOR ANCHORS AND FASTENERS FOR STEEL, CONCRETE AND MASONRY.

WOOD FRAME BUILDINGS  
 STUD WALLS OF DOOR OPENING SHALL BE FRAMED SOLID BY NOT LESS THAN (3) 2x6 PRESSURE TREATED SYP (GRADE #2 OR BETTER) WOOD STUDS OF A STRESS GRADE NOT LESS THAN 1200 PSI NOMINAL EXTREME FIBER STRESS IN BENDING (F<sub>b</sub>). STUD WALLS TO BE CONTINUOUS FROM FOOTING TO TIE BEAMS.

BLOCK WALL OR CONCRETE  
 2x6 SYP (GRADE #2 OR BETTER) WOOD JAMB SHALL BE ANCHORED TO GROUT REINFORCED BLOCK WALL OR CONCRETE COLUMN. BLOCK WALL CELLS SHALL BE FILLED WITH CONCRETE AND REINFORCED WITH REINFORCING BARS EXTENDING INTO THE FOOTING AND INTO THE BEAMS. ALL BARS SHALL BE CONTINUOUS FROM THE TIE BEAMS TO FOOTING PER BLOCK WALL OR CONCRETE COLUMN. BLOCK WALLS AND CONCRETE COLUMNS TO BE DESIGNED BY THE BUILDING ENGINEER OR ARCHITECT OF RECORD.

2x6 JAMB TO SUPPORTING STRUCTURE ATTACHMENT  
 (NOT TO BE USED FOR ATTACHMENT OF TRACK BRACKETS)

BUILDING TYPE	FASTENER TYPE	MAXIMUM * ON CENTER DISTANCE BETWEEN FASTENERS	STEEL WASHERS REQUIRED?
C-90 BLOCK (HOLLOW OR GROUTED)	1/4" x 3" (1-1/4" EMBED) ITW TAPCON CONCRETE ANCHOR (2-1/2" MIN. EDGE DISTANCE)	10-1/2"	1" O.D.
3,000 PSI MIN. CONCRETE	1/4" x 4" (1-3/4" EMBED) ITW TAPCON CONCRETE ANCHOR (2-1/2" MIN. EDGE DISTANCE)	24"	1" O.D.
3,000 PSI MIN. CONCRETE	1/2" x 4" (2-1/4" EMBED) SIMPSON STRONG-TIE WEDGE-ALL WEDGE ANCHOR (2" MIN. EDGE DISTANCE)	21-1/2"	INCLUDED
WOOD FRAME	1/2" x 4" (1-5/8" EMBED) LAG SCREW (ASTM A307, GRADE A) (2-1/2" MIN. EDGE DISTANCE)	24"	1" O.D.
2,000 PSI MIN. CONCRETE	1/2" x 4" (2-1/2" EMBED) WEJ-IT SLEEVE ANCHOR (2-1/2" MIN. EDGE DISTANCE)	24"	INCLUDED

\* - FIRST ANCHOR/SCREW STARTING FROM BOTTOM AT NO MORE THAN HALF OF MAXIMUM ON CENTER DISTANCE. HIGHEST ANCHOR/SCREW INSTALLED AT LEAST AS HIGH AS THE DOOR OPENING HEIGHT.

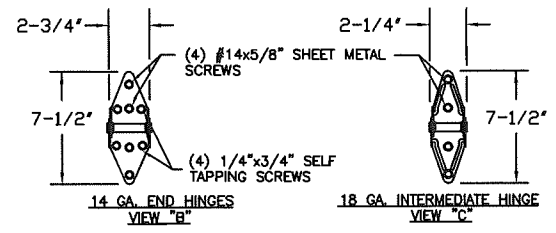

JAMB CONFIGURATION

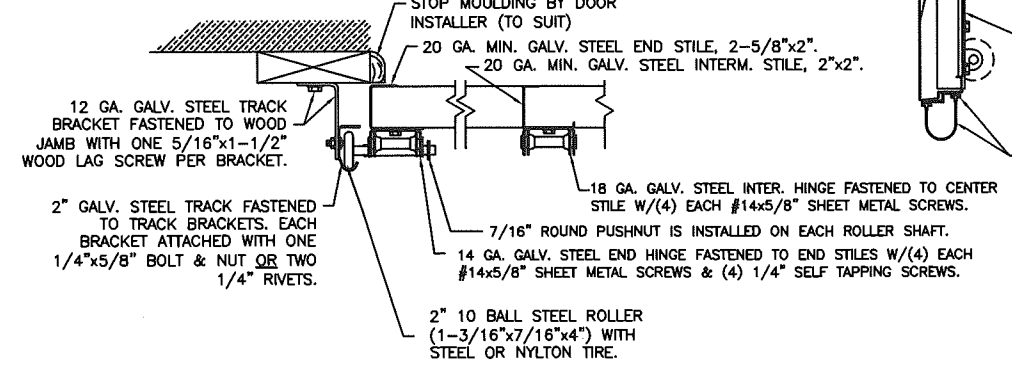

TOLERANCES  
 Unless Stated Otherwise  
 .00 ± .03  
 .000 ± .015  
 .0000 ± .007  
 Degrees ± 1/2

SCALE: 3/8" = 1'-0"  
 DATE: 10/23/06  
 CLOPAY CORPORATION  
 8585 DUKE BLVD.  
 MASON, OHIO 45040  
 (513) 770-4800

DESIGN LOADS: +48.0 PSF & -54.0 PSF.

PAGE: 1 OF 1	MAX. SIZE: 9'0"W x 16'0"H
DESCRIPTION: SINGLE CAR W8 PAN DOOR WITH IMPACT RESISTANT LITES	VER: MD
DRAWING NUMBER: 103547	

