



MIAMI-DADE COUNTY
PRODUCT CONTROL SECTION
11805 SW 26 Street, Room 208

DEPARTMENT OF REGULATORY AND ECONOMIC RESOURCES
(RER)

Miami, Florida 33175-2474

BOARD AND CODE ADMINISTRATION DIVISION

T (786) 315-2590 F (786) 315-2599

NOTICE OF ACCEPTANCE (NOA)

www.miamidade.gov/economy

**Clopay Corporation
8585 Duke Boulevard
Mason, OH 45040**

SCOPE:

This NOA is being issued under the applicable rules and regulations governing the use of construction materials. The documentation submitted has been reviewed and accepted by Miami-Dade County RER-Product Control Section to be used in Miami Dade County and other areas where allowed by the Authority Having Jurisdiction (AHJ).

This NOA shall not be valid after the expiration date stated below. The Miami-Dade County Product Control Section (In Miami Dade County) and/or the AHJ (in areas other than Miami Dade County) reserve the right to have this product or material tested for quality assurance purposes. If this product or material fails to perform in the accepted manner, the manufacturer will incur the expense of such testing and the AHJ may immediately revoke, modify, or suspend the use of such product or material within their jurisdiction. RER reserves the right to revoke this acceptance if it is determined by Miami-Dade County Product Control Section that this product or material fails to meet the requirements of the applicable building code.

This product is approved as described herein and has been designed to comply with the Florida Building Code, including the High Velocity Hurricane Zone.

DESCRIPTION: 2in EPS Insulated W6 DP38 Steel Sectional Garage Door up to 16ft-2in Wide w/ Optional Impact Resistant Lites

APPROVAL DOCUMENT: Drawing No. **104724**, titled "2" EPS Insulated Doors", sheets 1 through 3 of 3, dated 10/12/2012, with revision **8** dated 08/26/2020, prepared by Clopay Corporation, signed and sealed by Scott Hamilton, P.E. on 09/10/2020, bearing the Miami-Dade County Product Control revision stamp with the Notice of Acceptance number and expiration date by the Miami-Dade County Product Control Section.

MISSILE IMPACT RATING: Large and Small Missile Impact Resistant

LABELING: A permanent label with the manufacturer's name or logo, manufacturing address, model number, the positive and negative design pressure rating, indicate impact rated if applicable, installation instruction drawing reference number, approval number (NOA), the applicable test standards, and the statement reading 'Miami-Dade County Product Control Approved' is to be located on the door's side track, bottom angle, or inner surface of a panel.

RENEWAL of this NOA shall be considered after a renewal application has been filed and there has been no change in the applicable building code negatively affecting the performance of this product.

TERMINATION of this NOA will occur after the expiration date or if there has been a revision or change in the materials, use, and/or manufacture of the product or process. Misuse of this NOA as an endorsement of any product, for sales, advertising or any other purposes shall automatically terminate this NOA. Failure to comply with any section of this NOA shall be cause for termination and removal of NOA.

ADVERTISEMENT: The NOA number preceded by the words Miami-Dade County, Florida, and followed by the expiration date may be displayed in advertising literature. If any portion of the NOA is displayed, then it shall be done in its entirety.

INSPECTION: A copy of this entire NOA shall be provided to the user by the manufacturer or its distributors and shall be available for inspection at the job site at the request of the Building Official.

This NOA **revises NOA # 17-0920.03** and consists of this page 1 and evidence pages E-1, E-2 and E-3, as well as approval document mentioned above.

The submitted documentation was reviewed by **Carlos M. Utrera, P.E.**



NOA-No 20-0922.31
Expiration Date: December 27, 2022
Approval Date: November 25, 2020

NOTICE OF ACCEPTANCE: EVIDENCE SUBMITTED

1. EVIDENCE SUBMITTED UNDER PREVIOUS NOAs

A. DRAWINGS “Submitted under NOA # 15-0225.14”

1. Drawing No. **104724**, titled “2” EPS Insulated Doors”, sheets 1 through 3 of 3, dated 10/12/2012, with revision **05** dated 2/2015, prepared by Clopay Building Products Company, signed and sealed by Scott Hamilton, P.E.

B. TESTS “Submitted under NOA # 13-0402.03”

1. Addendum to Test Report No. **ATLNC 0801.01-12**, dated 02/06/2013, signed and sealed by David W. Johnson, P.E.

“Submitted under NOA # 12-1022.03”

2. Test reports on 1) Uniform Static Air Pressure Test, Loading per FBC TAS 202-94
2) Large Missile Impact Test per FBC, TAS 201-94
3) Cyclic Wind Pressure Loading per FBC, TAS 203-94
4) Forced Entry Test, per FBC 2411 3.2.1, TAS 202-94
5) Tensile Test per ASTM E8

Along with marked-up drawings and installation diagram of 16’2”x 8’, 27ga steel garage door Model 4300 with windows, prepared by American Test Lab, Inc., Test Report No. **ATLNC 0801.01-12**, dated 08/15/2012, signed and sealed by David W. Johnson, P.E.

3. Test report on Salt Spray per ASTM B117 of painted G40 galvanized coated panels, prepared by Stork Materials Technology, Test Report No. **30160-04-63365**, dated 01/26/2005, signed by John D. Lee, P.E.

C. CALCULATIONS “Submitted under NOA # 12-1022.03”

1. Jamb anchor calculations prepared by Clopay Building Products Company, dated 12/10/2012, signed and sealed by Scott Hamilton, P.E.

D. QUALITY ASSURANCE

1. Miami-Dade Department of Regulatory and Economic Resources (RER).

E. MATERIAL CERTIFICATIONS

1. Notice of Acceptance No. **15-0915.08** issued to SABIC Innovative Plastics, US LLC for their Lexan Polycarbonate Sheet Products, approved on 12/10/2015, expiring on 07/17/2018.
2. Test report on Surface Burning Characteristics, per ASTM E84 of Type I EPS, Test Report No. **3082960-500**, prepared by Intertek Testing Services, NA, Inc., dated 10/04/2005, signed by Javier Trevino.
3. Test report on Ignition Properties of Plastics per ASTM D1929 of Type I EPS, Test Report No. **3082959-500**, prepared by Intertek Testing Services, NA, Inc., dated 09/16/2005, signed by C. Anthony Peñaloza.



Carlos M. Utrera, P.E.
Product Control Examiner
NOA-No 20-0922.31

Expiration Date: December 27, 2022
Approval Date: November 25, 2020

NOTICE OF ACCEPTANCE: EVIDENCE SUBMITTED

F. STATEMENTS “Submitted under NOA # 15-0225.14”

1. Statement letter of code conformance with the 2010 and the 5th edition (2014) FBC issued by Clopay Building Products Company, dated 02/18/2015, signed and sealed by Scott Hamilton, P.E.

“Submitted under NOA # 12-1022.03”

2. Statement letters of code conformance to 2010 FBC and of no financial interest, issued by Clopay Building Products Company, dated 10/30/2012, signed and sealed by Scott Hamilton, P.E.

2. EVIDENCE SUBMITTED UNDER PREVIOUS NOA # 17-0920.03

A. DRAWINGS

1. Drawing No. **104724**, titled “2” EPS Insulated Doors”, sheets 1 through 3 of 3, dated 10/12/2012, with revision **6** dated 7/2017, prepared by Clopay Building Products Company, signed and sealed by Scott Hamilton, P.E.

B. TESTS

1. None.

C. CALCULATIONS

1. None.

D. QUALITY ASSURANCE

1. Miami-Dade Department of Regulatory and Economic Resources (RER).

E. MATERIAL CERTIFICATIONS

1. None.

F. STATEMENTS

1. Statement letter of code conformance to 5th Edition (2014) and 6th Edition (2017) FBC issued by Clopay Building Products Company, dated 09/06/2017, signed and sealed by Scott Hamilton, P.E.

2. Statement letter of no financial interest issued by Clopay Building Products Company, dated 09/06/2017, signed and sealed by Scott Hamilton, P.E.



Carlos M. Utrera, P.E.
Product Control Examiner
NOA-No 20-0922.31

Expiration Date: December 27, 2022
Approval Date: November 25, 2020

NOTICE OF ACCEPTANCE: EVIDENCE SUBMITTED

2. NEW EVIDENCE SUBMITTED

A. DRAWINGS

1. Drawing No. **104724**, titled “2” EPS Insulated Doors”, sheets 1 through 3 of 3, dated 10/12/2012, with revision **8** dated 08/26/2020, prepared by Clopay Corporation, dated 09/10/2020, signed and sealed by Scott Hamilton, P.E.

B. TESTS

1. None.

C. CALCULATIONS

1. None.

D. QUALITY ASSURANCE

1. Miami-Dade Department of Regulatory and Economic Resources (RER).

E. MATERIAL CERTIFICATIONS

1. None.

F. STATEMENTS

1. Statement letters of code conformance to **6th Edition (2017) and 7th Edition (2020) FBC**, issued by Clopay Corporation, dated 09/15/2020, signed and sealed by Scott Hamilton, P.E.
2. Certificate of amendment changing the company name from Clopay Building Products Company, Inc. to Clopay Corporation, issued by the State of Delaware, dated 08/27/2019.



Carlos M. Utrera, P.E.
Product Control Examiner
NOA-No 20-0922.31

Expiration Date: December 27, 2022
Approval Date: November 25, 2020

MODELS	24 GA SHORT	27 GA SHORT	27 GA FLUSH	27 GA LONG
CLOPAY	4400, 4401	4300, HDG	4301, HDGF	4310, HDGL
HOLMES	--	66, 66G, 6200	68, 6201	67, 67G, 6203
IDEAL	--	SP200	SF200	SE200

SHEET:
1 OF 3

REVISIONS					
REV. NO.	ZONE:	DATE:	ECN NO.	APPVD:	DESCRIPTION
06	-	7/2017	-	SH	UPDATED CODE COMPLIANCE STATEMENT TO ADD 6TH EDITION FBC.
07	-	2/4/20	EN2736	SH	REVISED MAX WINDOW SIZE AND TITLE BLOCK
08	-	8/26/20	-	SH	UPDATED CODE COMPLIANCE STATEMENT TO 7TH

(1) 20 GA. BACKER PLATE BETWEEN EACH EMBOSS LOCATION THAT CONTAINS A CENTER HINGE. ATTACHED WITH DOUBLE SIDED ACRYLIC ADHESIVE TO BACK OF DOOR.

OPTIONAL ROW OF IMPACT-RESISTANT GLAZING. MAX. GLAZING SIZE IS 19-1/2" x 12". SEE SECTION B-B FOR ASSEMBLY DETAILS. (GLAZING SHOWN IN INTERMEDIATE SECTION.)

IMPACT-RESISTANT CONSTRUCTION:
SOLID DOORS (NO GLAZING) OR DOORS WITH OPTIONAL IMPACT-RESISTANT GLAZING ARE IMPACT-RESISTANT. OPTIONAL INJECTION-MOLDED POLYCARBONATE FRONT FRAME AND GLAZING IS GE LEXAN SLX2432T, AN APPROVED CC2 PLASTIC IN ACCORDANCE WITH IBC/FBC 2606. THE ENTIRE DOOR ASSEMBLY INSTALLED IN COMPLIANCE WITH THIS SECTION MEETS THE WIND LOAD REQUIREMENTS OF THE FLORIDA BUILDING CODE AND INTERNATIONAL BUILDING CODE AND IS LARGE- AND SMALL-MISSILE IMPACT RESISTANT.

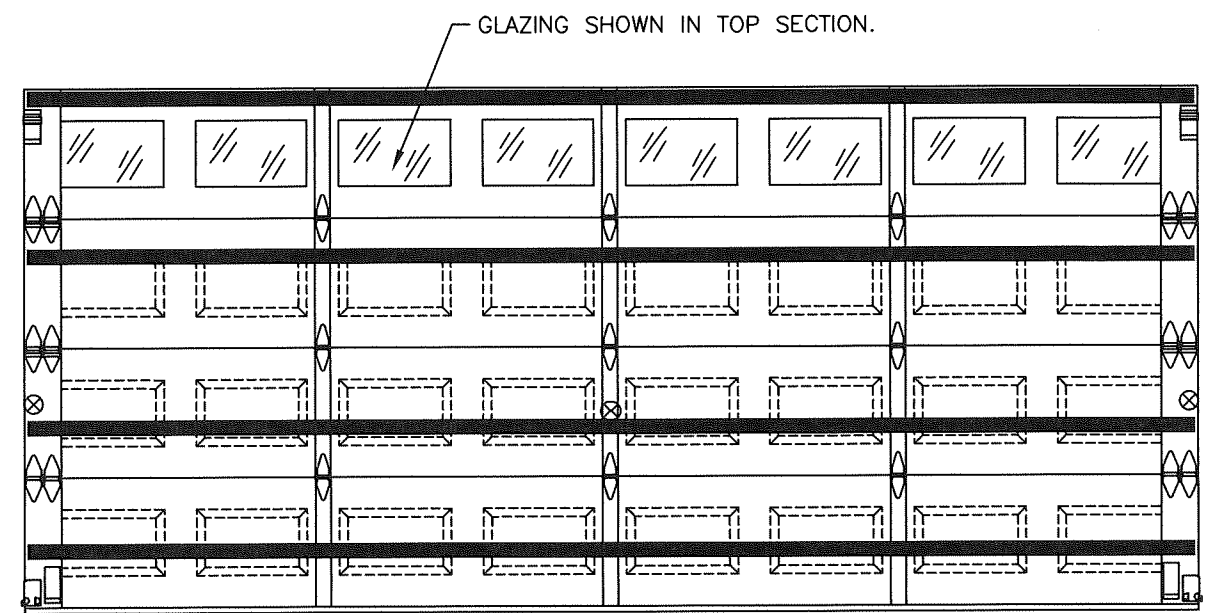
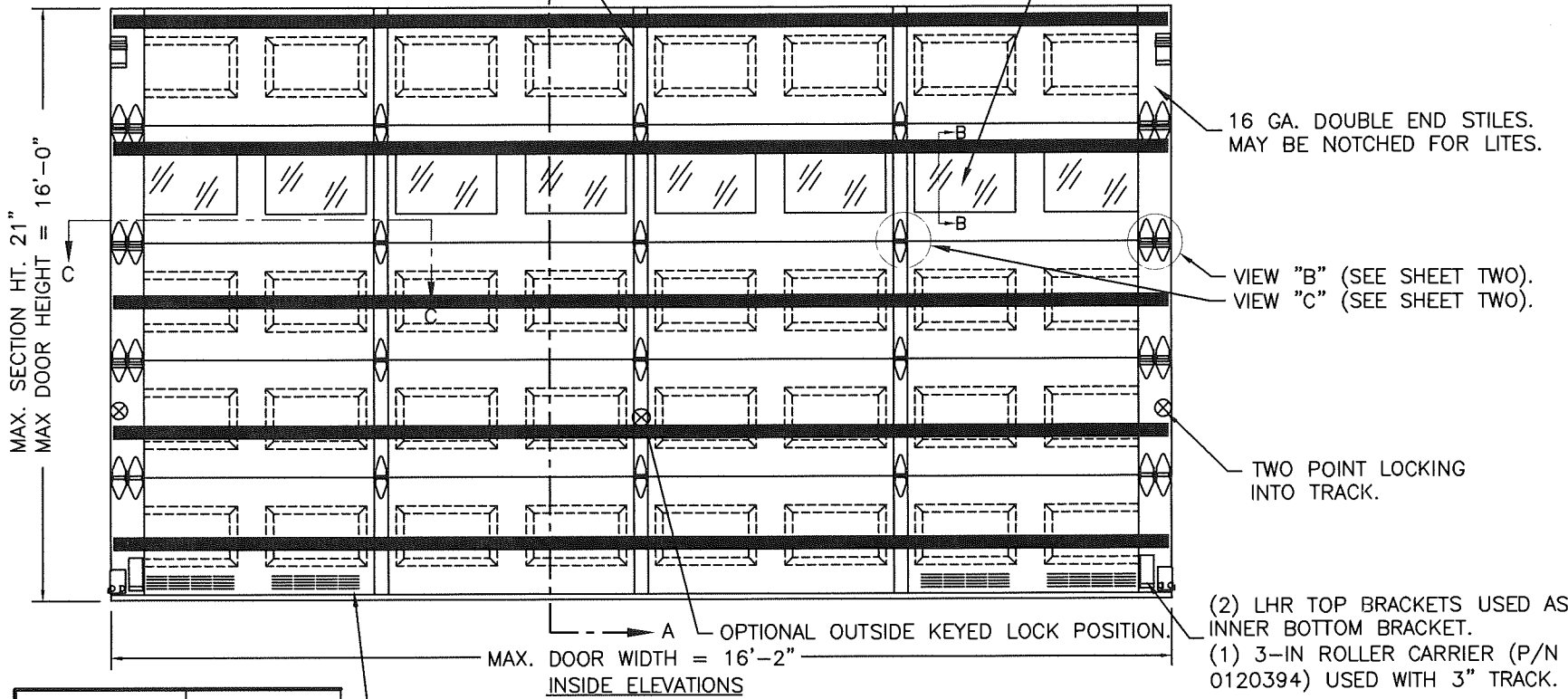

DOOR HEIGHT	# OF SECTIONS
UP TO 7'0"	4
7'3" TO 8'9"	5
9'0" TO 10'6"	6
10'9" TO 12'3"	7
12'6" TO 14'0"	8
14'3" TO 15'9"	9
16'0"	10

MAX SECTION HEIGHT: 21'

LOCATION OF OPTIONAL VENTS. TOTAL VENT OPENINGS: 60 IN² PER VEHICLE. VENTS SHALL BE IN ACCORDANCE WITH CLOPAY DRAWING 101845.

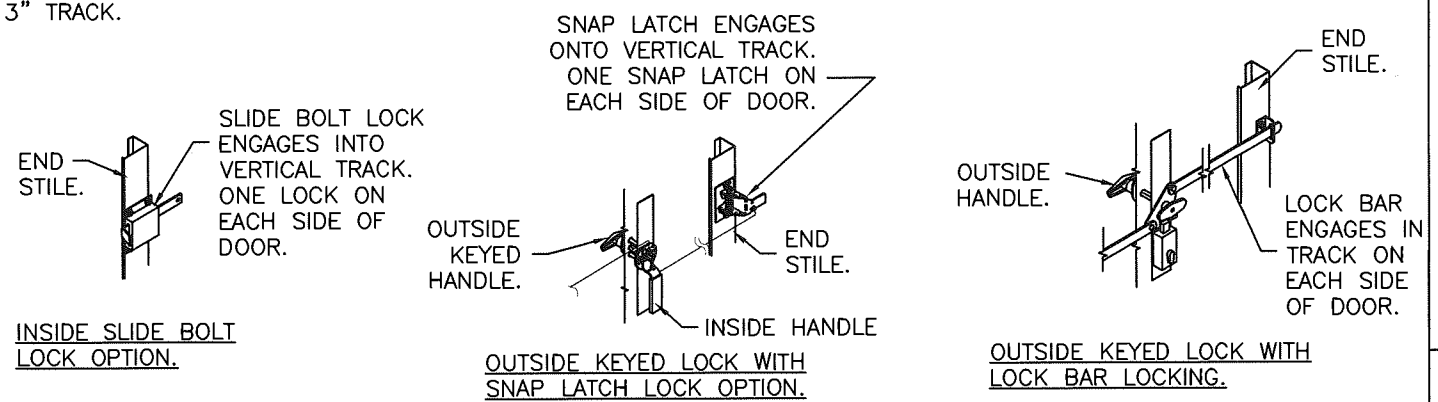
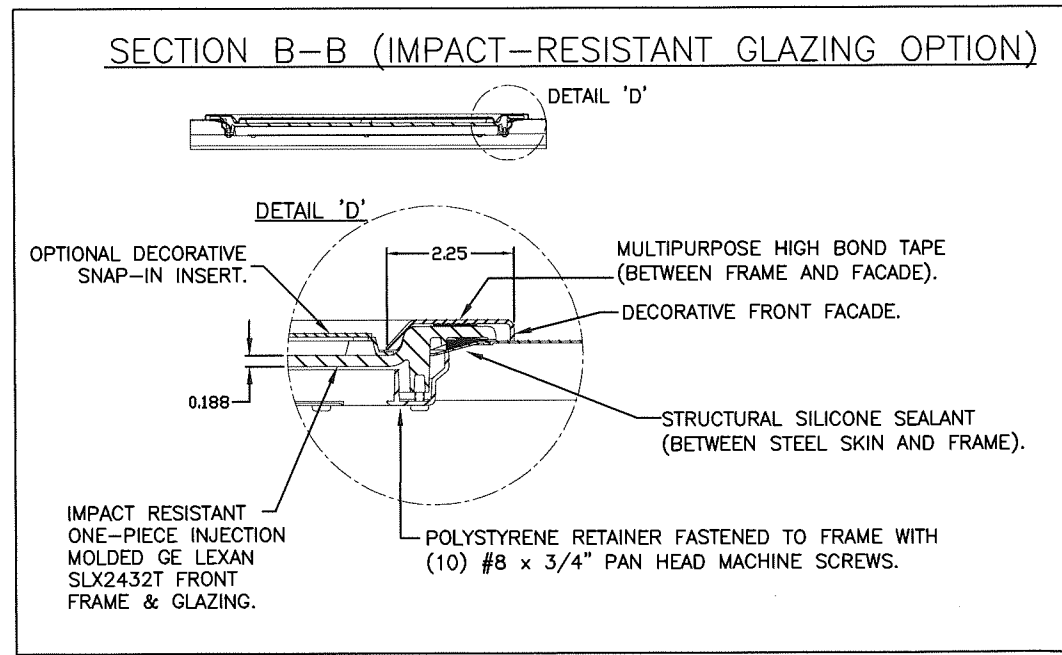

THIS PRODUCT CONFORMS TO THE REQUIREMENTS OF 6TH AND 7TH EDITION OF THE FLORIDA BUILDING CODE

DESIGN LOADS: +38.0 P.S.F. & -42.0 P.S.F.	PART NO.: N/A
Unless Stated Otherwise TOLERANCES are .0 = ±.031 .00 = ±.015 .000 = ±.005 .0000 = ±.001 Degrees = ±1/2° Unless Stated Otherwise DIMENSIONS ARE IN INCHES.	Glopay CORPORATION 8585 Duke Boulevard Mason, OH 45040 USA Tel. No. 513-770-4800 Fax No. 513-770-4853
DESCRIPTION: 2" EPS INSULATED DOORS (SEE TABLE FOR MODELS)	WINDLOAD RATING W6 DP38
DRAWN BY: SH	DATE: 9/28/12
CHECKED BY: SH	DATE: 10/12/12
DWG. NO.: 104724	VER: MD

PRODUCT REVISED
as complying with the Florida Building Code
NOA-No. 20-0922.31
Expiration Date 12/27/2022
By *[Signature]*
Miami-Dade Product Control

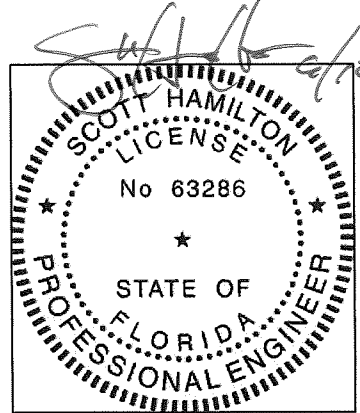

DESIGN ENGINEER:
SCOTT HAMILTON, P.E.
FLORIDA LICENSE No. 63286

MODELS	24 GA SHORT	27 GA SHORT	27 GA FLUSH	27 GA LONG
CLOPAY	4400, 4401	4300, HDG	4301, HDGF	4310, HDGL
HOLMES	--	66, 66G, 6200	68, 6201	67, 67G, 6203
IDEAL	--	SP200	SF200	SE200

SHEET:
2 OF 3

REVISIONS					
REV. NO.	ZONE:	DATE:	ECN NO.	APPVD:	DESCRIPTION
08	-	-	-	-	SEE REVISION HISTORY ON SHEET ONE.

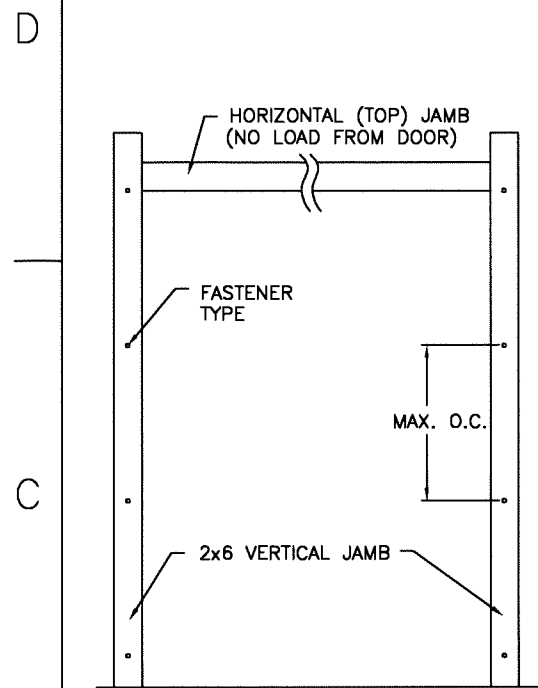

JAMB TO SUPPORTING STRUCTURE ATTACHMENT

- NOTES:**
1. ALL THE LOAD FROM THE DOOR IS TRANSFERRED TO THE TRACK AND THEN FROM THE TRACK TO THE 2x6 VERTICAL SYP (GRADE #2 OR BETTER) JAMBS. NO LOAD FROM THE DOOR IS TRANSFERRED TO THE HORIZONTAL (TOP) JAMB.
 2. EACH VERTICAL JAMB SEES A MAXIMUM DESIGN LOAD OF +304 LB & -336 LB. PER LINEAR FOOT OF JAMB.
 3. ALL JAMB FASTENERS MAY BE (BUT ARE NOT REQUIRED TO BE) COUNTERSUNK TO PROVIDE A FLUSH MOUNTING SURFACE.
 4. A 1/3 STRESS INCREASE FOR WIND LOAD WAS NOT USED IN THE CALCULATION OF ALLOWABLE LOADS FOR ANCHORS AND FASTENERS FOR STEEL, CONCRETE AND MASONRY.

WOOD FRAME BUILDINGS

STUD WALLS OF DOOR OPENING SHALL BE FRAMED SOLID BY NOT LESS THAN (3) 2x6 PRESSURE TREATED SYP (GRADE #2 OR BETTER) WOOD STUDS OF A STRESS GRADE NOT LESS THAN 1200 PSI NOMINAL EXTREME FIBER STRESS IN BENDING (F_b) FOR DOORS UP TO 8'0" HIGH OR (4) 2x6 PRESSURE TREATED SYP (GRADE #2 OR BETTER) WOOD STUDS OF A STRESS GRADE NOT LESS THAN 1200 PSI NOMINAL EXTREME FIBER STRESS IN BENDING (F_b) FOR DOORS UP TO 16'0" HIGH. STUD WALLS TO BE CONTINUOUS FROM FOOTING TO TIE BEAMS.

BLOCK WALL OR CONCRETE

2x6 SYP (GRADE #2 OR BETTER) WOOD JAMB SHALL BE ANCHORED TO GROUT REINFORCED BLOCK WALL OR CONCRETE COLUMN. BLOCK WALL CELLS SHALL BE FILLED WITH CONCRETE AND REINFORCED WITH REINFORCING BARS EXTENDING INTO THE FOOTING AND INTO TIE BEAMS. ALL BARS SHALL BE CONTINUOUS FROM THE TIE BEAMS TO FOOTING PER BLOCK WALL OR CONCRETE COLUMN. BLOCK WALLS AND CONCRETE COLUMNS TO BE DESIGNED BY THE BUILDING ENGINEER OR ARCHITECT OF RECORD AND IN ACCORDANCE WITH THE FLORIDA BUILDING CODE.

2x6 JAMB TO SUPPORTING STRUCTURE ATTACHMENT
(NOT TO BE USED FOR ATTACHMENT OF TRACK ANGLE TO 2x6 VERTICAL JAMBS OR SUPPORTING STRUCTURE)

BUILDING TYPE	FASTENER TYPE	MAXIMUM ON-CENTER DISTANCE BETWEEN FASTENERS*	STEEL WASHERS REQUIRED?
BLOCK WALL	1/4" x 1-1/4" MIN. EMBED TAPCON CONCRETE ANCHOR	7-1/2"	1" O.D.
3000 PSI MIN. CONCRETE	1/4" x 1" MIN. EMBED TAPCON CONCRETE ANCHOR	8-1/4"	1" O.D.
2000 PSI MIN. CONCRETE	3/8" x 1-3/4" MIN. EMBED WEJ-IT ANKR TITE SLEEVE ANCHOR	16-1/2"	INCLUDED
4000 PSI MIN. CONCRETE	3/8" x 1-3/4" MIN. EMBED WEJ-IT ANKR TITE SLEEVE ANCHOR	24"	INCLUDED
WOOD FRAME (SYP 0.55 SG)	1/2" x 3" LAG SCREW (ASTM A307, GRADE A) 1-5/8" EMBED INTO STRUCTURE	17-3/4"	1" O.D.

* FIRST (BOTTOM) ANCHOR STARTING AT NO MORE THAN HALF OF THE MAXIMUM ON-CENTER DISTANCE. HIGHEST ANCHOR INSTALLED AT LEAST AS HIGH AS THE DOOR OPENING.
CLOPAY DOES NOT SUPPLY JAMB ATTACHMENT FASTENERS.
MINIMUM DISTANCE BETWEEN CENTER OF ANCHOR AND EDGE OF CONCRETE BLOCK: 2-1/2", EXCLUDING STUCCO THICKNESS.

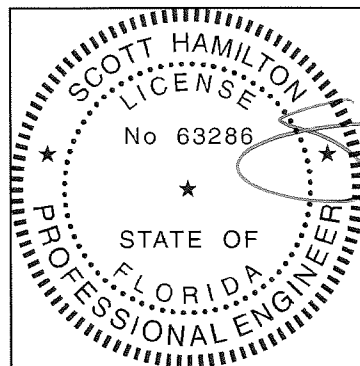

DESIGN ENGINEER:
SCOTT HAMILTON, P.E.
FLORIDA LICENSE No. 63286

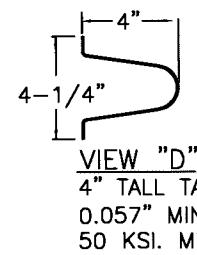
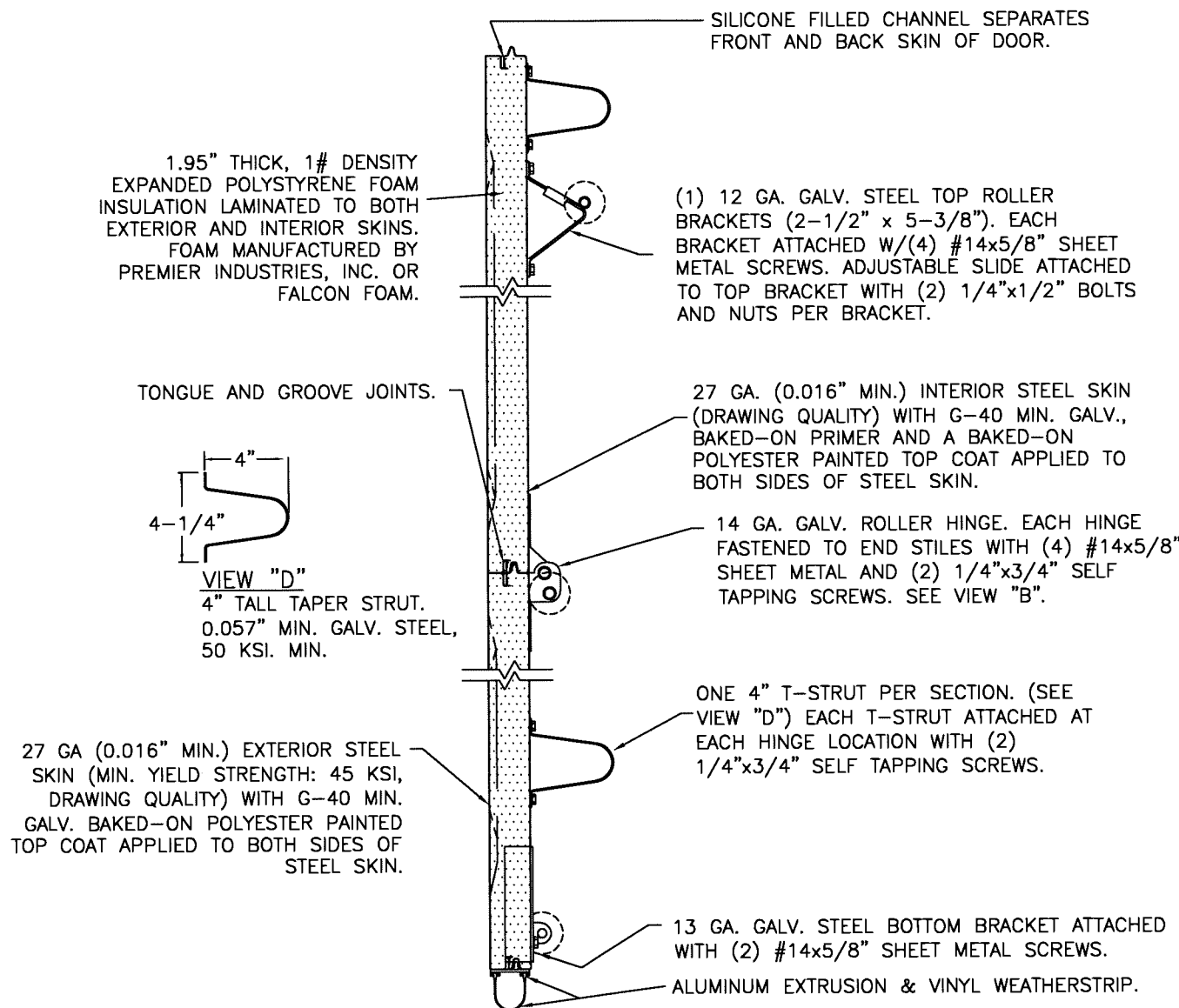
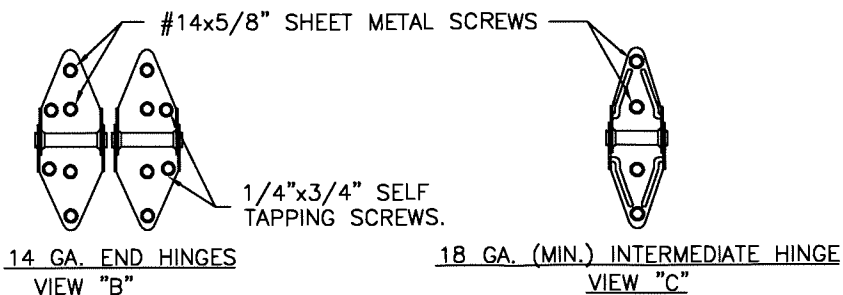

SECTION A-A (SIDE VIEW)

PRODUCT REVISED
as complying with the Florida Building Code
NOA-No. 20-0922.31
Expiration Date 12/27/2022
By *[Signature]*
Miami-Dade Product Control

DESIGN LOADS: +38.0 P.S.F. & -42.0 P.S.F.	PART NO.: N/A
Unless Stated Otherwise TOLERANCES are .0 = ±.031 .00 = ±.015 .000 = ±.005 .0000 = ±.001 Degrees = ±1/2"	WINDLOAD RATING W6 DP38
Clopay CORPORATION 8585 Duke Boulevard Mason, OH 45040 USA Tel. No. 513-770-4800 Fax No. 513-770-4853	DESCRIPTION: 2" EPS INSULATED DOORS (SEE TABLE FOR MODELS)
DRAWN BY: SH	DATE: 9/28/12
CHECKED BY: SH	DATE: 10/12/12
DWG. NO.: 104724	VER: MD

MODELS	24 GA SHORT	27 GA SHORT	27 GA FLUSH	27 GA LONG
CLOPAY	4400, 4401	4300, HDG	4301, HDGF	4310, HDGL
HOLMES	--	66, 66G, 6200	68, 6201	67, 67G, 6203
IDEAL	--	SP200	SF200	SE200

SHEET:
3 OF 3

REVISIONS					
REV. NO.	ZONE:	DATE:	ECN NO.	APPVD:	DESCRIPTION
08	-	-	-	-	SEE REVISION HISTORY ON SHEET ONE.

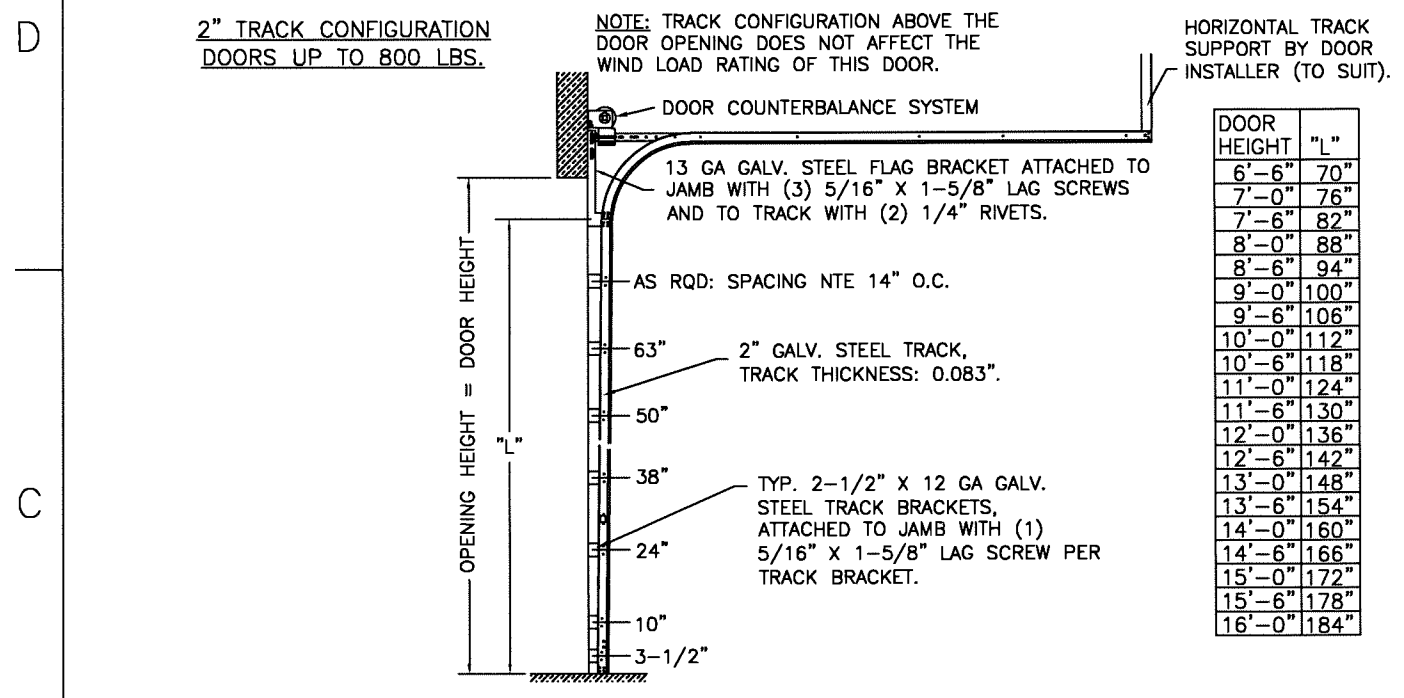

DOOR HEIGHT	"L"
6'-6"	70"
7'-0"	76"
7'-6"	82"
8'-0"	88"
8'-6"	94"
9'-0"	100"
9'-6"	106"
10'-0"	112"
10'-6"	118"
11'-0"	124"
11'-6"	130"
12'-0"	136"
12'-6"	142"
13'-0"	148"
13'-6"	154"
14'-0"	160"
14'-6"	166"
15'-0"	172"
15'-6"	178"
16'-0"	184"

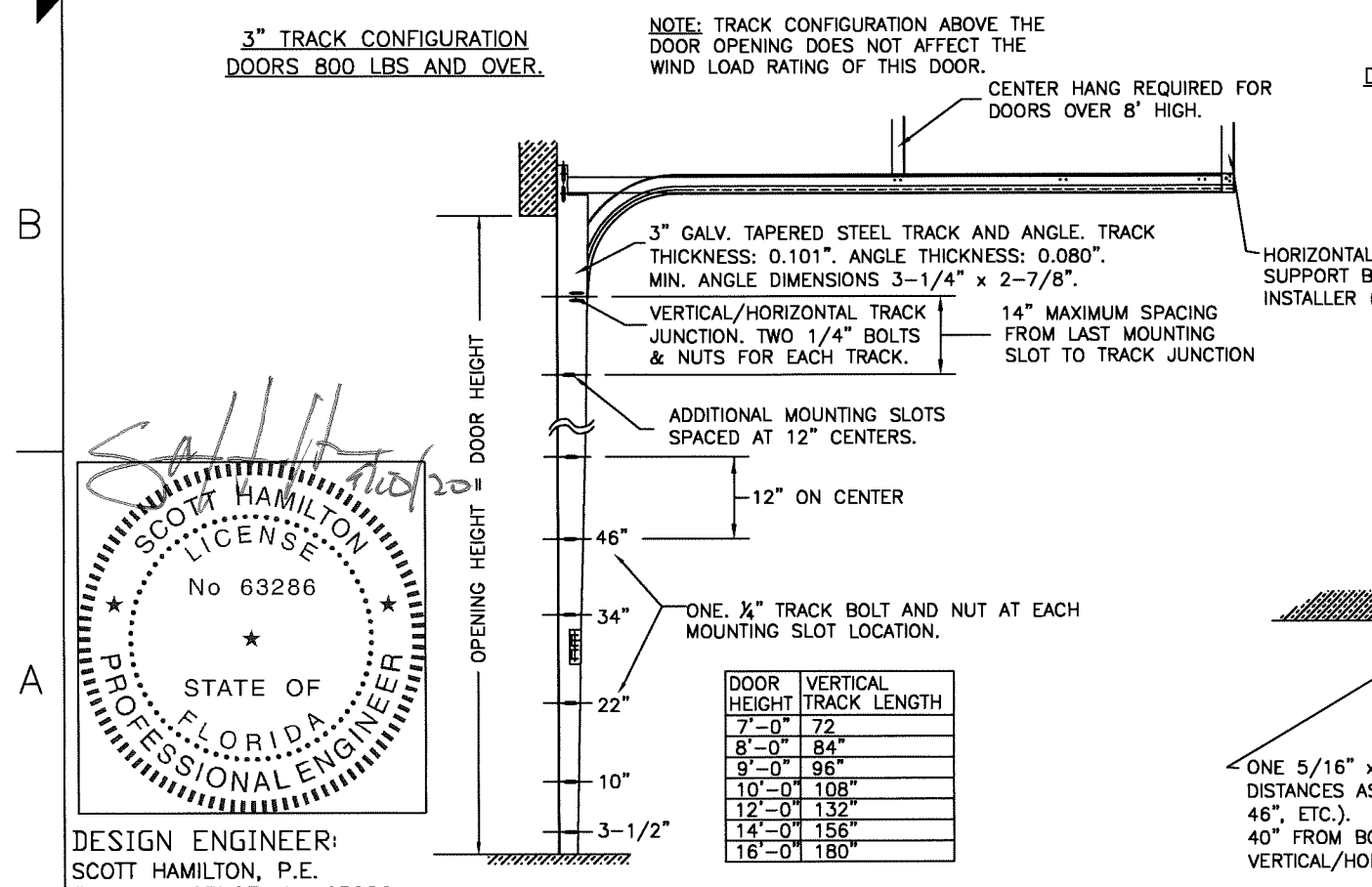
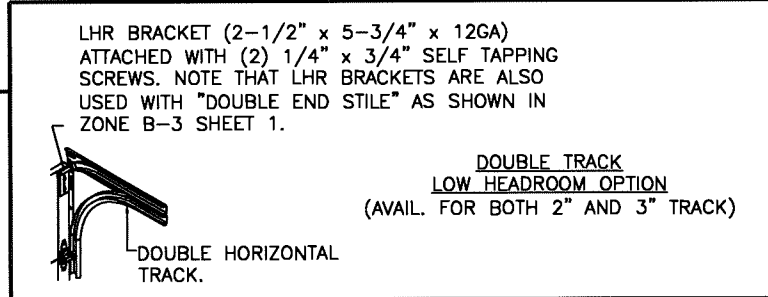
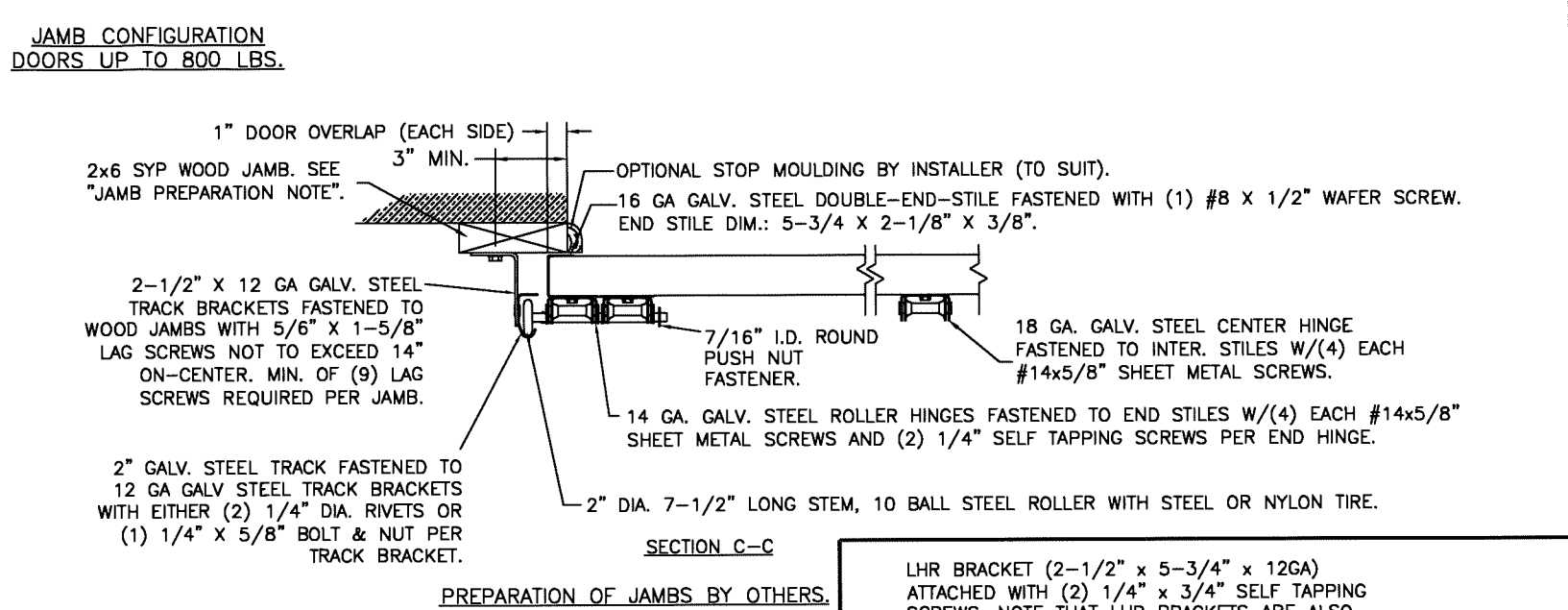

DOOR HEIGHT	VERTICAL TRACK LENGTH
7'-0"	72"
8'-0"	84"
9'-0"	96"
10'-0"	108"
12'-0"	132"
14'-0"	156"
16'-0"	180"

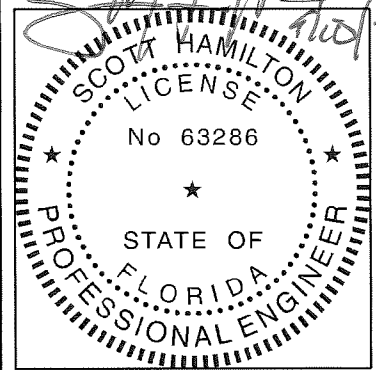
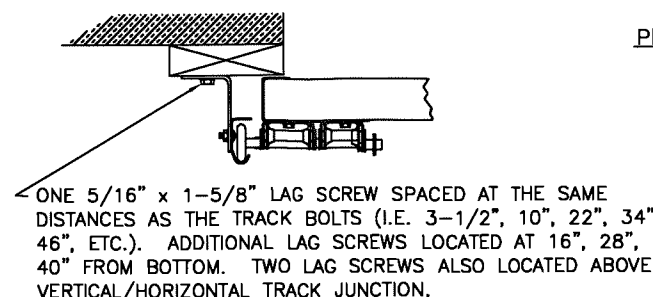
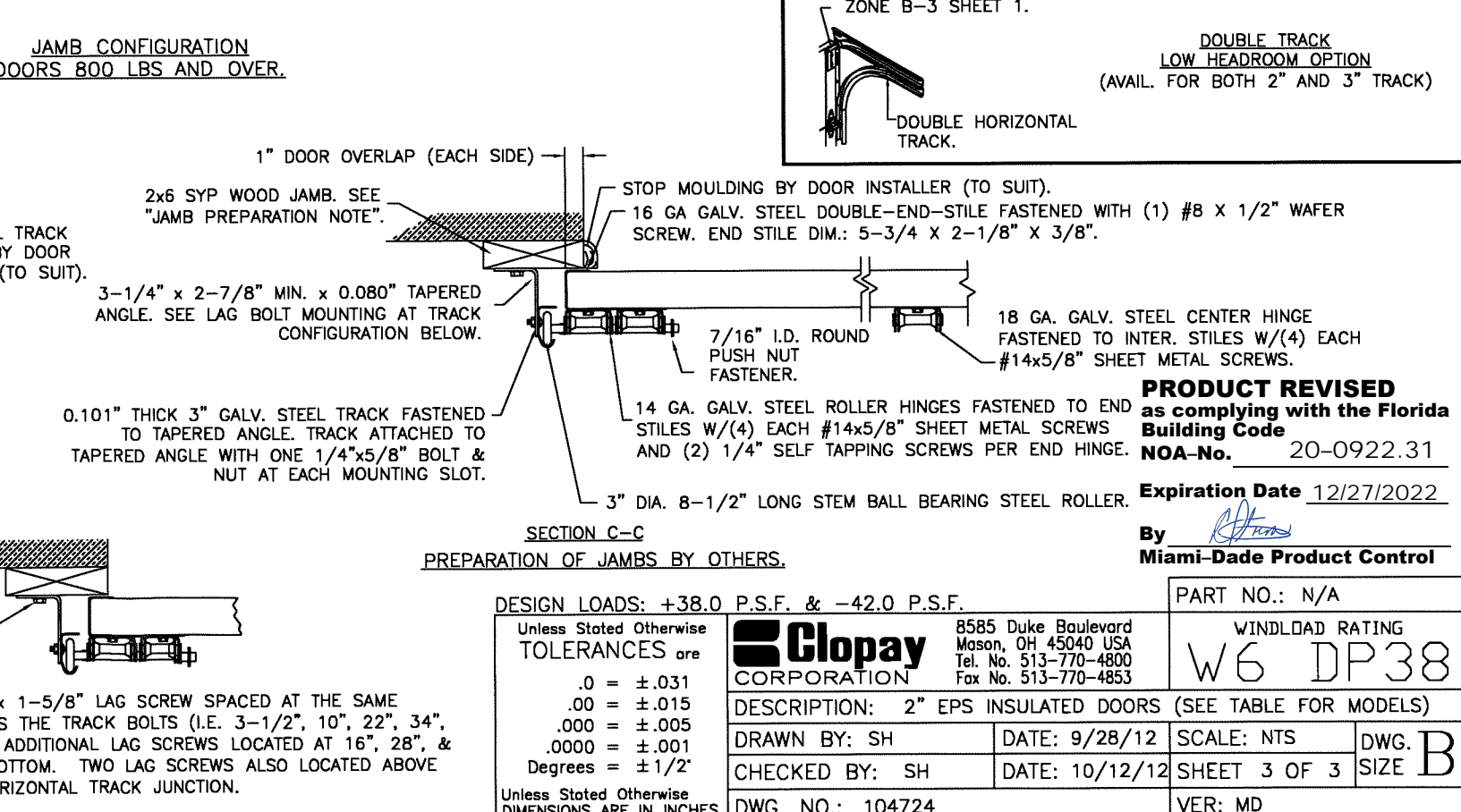

DESIGN ENGINEER:
SCOTT HAMILTON, P.E.
FLORIDA LICENSE No. 63286

DESIGN LOADS: +38.0 P.S.F. & -42.0 P.S.F.

Unless Stated Otherwise TOLERANCES are

.0	= ±.031
.00	= ±.015
.000	= ±.005
.0000	= ±.001
Degrees	= ±1/2°

Unless Stated Otherwise DIMENSIONS ARE IN INCHES.

Clopay CORPORATION
8585 Duke Boulevard
Mason, OH 45040 USA
Tel. No. 513-770-4800
Fax No. 513-770-4853

PART NO.: N/A

WINDLOAD RATING
W6 DP38

DESCRIPTION: 2" EPS INSULATED DOORS (SEE TABLE FOR MODELS)

DRAWN BY: SH DATE: 9/28/12 SCALE: NTS DWG. B

CHECKED BY: SH DATE: 10/12/12 SHEET 3 OF 3 SIZE B

DWG. NO.: 104724 VER: MD

PRODUCT REVISED
as complying with the Florida Building Code
NOA-No. 20-0922.31

Expiration Date 12/27/2022

By *[Signature]*
Miami-Dade Product Control