



**DEPARTMENT OF REGULATORY AND ECONOMIC RESOURCES (RER)
BOARD AND CODE ADMINISTRATION DIVISION
NOTICE OF ACCEPTANCE (NOA)**

**MIAMI-DADE COUNTY
PRODUCT CONTROL SECTION**
11805 SW 26 Street, Room 208
Miami, Florida 33175-2474
T (786) 315-2590 F (786) 315-2599
www.miamidade.gov/economy

**Clopay Corporation
8585 Duke Boulevard
Mason, OH 45040**

SCOPE:

This NOA is being issued under the applicable rules and regulations governing the use of construction materials. The documentation submitted has been reviewed and accepted by Miami-Dade County RER-Product Control Section to be used in Miami-Dade County and other areas where allowed by the Authority Having Jurisdiction (AHJ).

This NOA shall not be valid after the expiration date stated below. The Miami-Dade County Product Control Section (In Miami-Dade County) and/ or the AHJ (in areas other than Miami-Dade County) reserve the right to have this product or material tested for quality assurance purposes. If this product or material fails to perform in the accepted manner, the manufacturer will incur the expense of such testing and the AHJ may immediately revoke, modify, or suspend the use of such product or material within their jurisdiction. RER reserves the right to revoke this acceptance, if it is determined by Miami-Dade County Product Control Section that this product or material fails to meet the requirements of the applicable building code.

This product is approved as described herein and has been designed to comply with the Florida Building Code, including the High Velocity Hurricane Zone.

DESCRIPTION: 2in Gallery EPS Insulated W6 DP38T Steel Sectional Garage Door up to 16ft-2in Wide w/ Optional Impact Resistant Lites

APPROVAL DOCUMENT: Drawing No. **104785**, titled “2” Gallery EPS Doors 16’2”W”, sheets 1 through 3 of 3, dated 01/10/2013, with revision **06** dated 08/28/2020, prepared by Clopay Corporation, dated 09/10/2020, signed and sealed by Scott Hamilton, P.E., bearing the Miami-Dade County Product Control revision stamp with the Notice of Acceptance number and expiration date by the Miami-Dade County Product Control Section.

MISSILE IMPACT RATING: Large and Small Missile Impact Resistant

LABELING: A permanent label with the manufacturer’s name or logo, manufacturing address, model number, the positive and negative design pressure rating, indicate impact rated if applicable, installation instruction drawing reference number, approval number (NOA), the applicable test standards, and the statement reading ‘Miami-Dade County Product Control Approved’ is to be located on the door’s side track, bottom angle, or inner surface of a panel.

RENEWAL of this NOA shall be considered after a renewal application has been filed and there has been no change in the applicable building code negatively affecting the performance of this product.

TERMINATION of this NOA will occur after the expiration date or if there has been a revision or change in the materials, use, and/ or manufacture of the product or process. Misuse of this NOA as an endorsement of any product, for sales, advertising or any other purposes shall automatically terminate this NOA. Failure to comply with any section of this NOA shall be cause for termination and removal of NOA.

ADVERTISEMENT: The NOA number preceded by the words Miami-Dade County, Florida, and followed by the expiration date may be displayed in advertising literature. If any portion of the NOA is displayed, then it shall be done in its entirety.

INSPECTION: A copy of this entire NOA shall be provided to the user by the manufacturer or its distributors and shall be available for inspection at the job site at the request of the Building Official.

This NOA revises NOA # **18-0510.02** and consists of this page 1 and evidence pages E-1, E-2, E-3 and E-4, as well as approval document mentioned above.

The submitted documentation was reviewed by **Carlos M. Utrera, P.E.**



**NOA-No. 20-0922.32
Expiration Date: July 18, 2023
Approval Date: November 25, 2020
Page 1**

NOTICE OF ACCEPTANCE: EVIDENCE SUBMITTED

1. EVIDENCE SUBMITTED UNDER PREVIOUS NOA'S

A. DRAWINGS “Submitted under NOA # 14-0203.06”

1. Drawing No. **104785**, titled “2” Gallery EPS Doors 16’2”W”, sheets 1 through 3 of 3, dated 01/10/2013, with revision **04** dated 09/20/2016, prepared by Clopay Building Products Company, signed and sealed by Scott Hamilton, P.E.

B. TESTS “Submitted under NOA # 14-0203.06”

1. Test reports on
 - 1) Uniform Static Air Pressure Test, Loading per FBC TAS 202-94
 - 2) Large Missile Impact Test per FBC, TAS 201-94
 - 3) Cyclic Wind Pressure Loading per FBC, TAS 203-94
 - 4) Forced Entry Test per FBC, TAS 202-94
 - 5) Tensile Test per ASTM E8

Along with marked-up drawings and installation diagram of 16’2”x 8’, 27ga steel garage door Model GD2LPW8 with windows, prepared by American Test Lab, Inc., Test Report No. **ATLNC 1202.02-13**, dated 01/14/2014, signed and sealed by David W. Johnson, P.E.

“Submitted under NOA # 13-0423.15”

2. Test reports on
 - 1) Uniform Static Air Pressure Test, Loading per FBC TAS 202-94
 - 2) Large Missile Impact Test per FBC, TAS 201-94
 - 3) Cyclic Wind Pressure Loading per FBC, TAS 203-94
 - 4) Forced Entry Test, per FBC, TAS 202-94
 - 5) Tensile Test per ASTM E8

Along with marked-up drawings and installation diagram of 16’2”x 8’, 27ga steel garage door Model GD2LPW6 with windows, prepared by American Test Lab, Inc., Test Report No. **ATLNC 0115-01-13R**, dated 03/18/2013, signed and sealed by David W. Johnson, P.E.

3. Test report on Salt Spray per ASTM B117 of painted G40 galvanized coated panels, prepared by Stork Materials Technology, Test Report No. **30160-04-63365**, dated 01/26/2005, signed by John D. Lee, P.E.

C. CALCULATIONS “Submitted under NOA # 13-0423.15”

1. Jamb anchor calculations prepared by Clopay Building Products Company, dated 04/16/2013, signed and sealed by Scott Hamilton, P.E.

D. QUALITY ASSURANCE

1. Miami-Dade Department of Regulatory and Economic Resources (RER).

E. MATERIAL CERTIFICATIONS

1. Notice of Acceptance No. **13-0717.01** issued to SABIC Innovative Plastics for their Lexan Polycarbonate Sheet Products, approved on 11/28/2013, expiring on 07/17/2018.
2. Test report on Surface Burning Characteristics, per ASTM E84 of Type I EPS, Test Report No. **3082960-500**, prepared by Intertek Testing Services, NA, Inc., dated 10/04/2005, signed by Javier Trevino.



Carlos M. Utrera, P.E.
Product Control Examiner
NOA-No. 20-0922.32
Expiration Date: July 18, 2023
Approval Date: November 25, 2020

Clopay Corporation

NOTICE OF ACCEPTANCE: EVIDENCE SUBMITTED

E. MATERIAL CERTIFICATIONS (Continued)

3. Test report on Ignition Properties of Plastics per ASTM D1929 of Type I EPS, Test Report No. **3082959-500**, prepared by Intertek Testing Services, NA, Inc., dated 09/16/2005, signed by C. Anthony Peñaloza.

F. STATEMENTS “Submitted under NOA # 15-0225.21”

1. Statement letter of code conformance with the 2010 and the 5th edition (2014) FBC issued by Clopay Building Products Company, dated 02/18/2015, signed and sealed by Scott Hamilton, P.E.

“Submitted under NOA # 13-0423.15”

2. Statement letters of code conformance to 2010 FBC and no financial interest, both issued by Clopay Building Products Company, dated 04/16/2013, signed and sealed by Scott Hamilton, P.E.

2. EVIDENCE SUBMITTED UNDER PREVIOUS NOA’S

A. DRAWINGS “Submitted under NOA # 17-1016.26”

1. Drawing No. **104785**, titled “2” Gallery EPS Doors 16’2”W”, sheets 1 through 3 of 3, dated 01/10/2013, with revision **05** dated 07/18/2017, prepared by Clopay Building Products Company, signed and sealed by Scott Hamilton, P.E.

B. TESTS

1. None.

C. CALCULATIONS

1. None.

D. QUALITY ASSURANCE

1. Miami-Dade Department of Regulatory and Economic Resources (RER).

E. MATERIAL CERTIFICATIONS

1. None.

F. STATEMENTS “Submitted under NOA # 17-1016.26”

1. Statement letter of code conformance to the 6th edition (2017) FBC issued by Clopay Building Products Company, dated 10/04/2017, signed and sealed by Scott Hamilton, P.E.



Carlos M. Utrera, P.E.
Product Control Examiner
NOA-No. 20-0922.32
Expiration Date: July 18, 2023
Approval Date: November 25, 2020

Clopay Corporation

NOTICE OF ACCEPTANCE: EVIDENCE SUBMITTED

3. EVIDENCE SUBMITTED UNDER PREVIOUS NOA # 18-0510.02

A. DRAWINGS

1. Drawing No. **104785**, titled “2” Gallery EPS Doors 16’2”W”, sheets 1 through 3 of 3, dated 01/10/2013, with revision **05** dated 07/18/2017, prepared by Clopay Building Products Company, dated 04/27/2018, signed and sealed by Scott Hamilton, P.E.

B. TESTS

1. None.

C. CALCULATIONS

1. None.

D. QUALITY ASSURANCE

1. Miami-Dade Department of Regulatory and Economic Resources (RER).

E. MATERIAL CERTIFICATIONS

1. Notice of Acceptance No. 15-0915.08 issued to Sabic Innovative Plastic, US, LLC for their “LEXAN® Polycarbonate Sheet Products” dated 12/10/15, expiring on 07/17/18.

F. STATEMENTS

1. Statement letter of code conformance to the 6th edition (2017) FBC issued by Clopay Building Products Company, dated 04/27/2018, signed and sealed by Scott Hamilton, P.E.
2. Statement letter of no financial interests issued by Clopay Building Products Company, dated 04/27/2018, signed and sealed by Scott Hamilton, P.E.



Carlos M. Utrera, P.E.
Product Control Examiner
NOA-No. 20-0922.32
Expiration Date: July 18, 2023
Approval Date: November 25, 2020

Clopay Corporation

NOTICE OF ACCEPTANCE: EVIDENCE SUBMITTED

4. NEW EVIDENCE SUBMITTED

A. DRAWINGS

1. Drawing No. **104785**, titled "2" Gallery EPS Doors 16'2"W", sheets 1 through 3 of 3, dated 01/10/2013, with revision **06** dated 08/28/2020, prepared by Clopay Corporation, dated 09/10/2020, signed and sealed by Scott Hamilton, P.E.

B. TESTS

1. None.

C. CALCULATIONS

1. None.

D. QUALITY ASSURANCE

1. Miami-Dade Department of Regulatory and Economic Resources (RER).

E. MATERIAL CERTIFICATIONS

1. None.

F. STATEMENTS

1. Statement letters of code conformance to **6th Edition (2017) and 7th Edition (2020) FBC**, issued by Clopay Corporation, dated 09/15/2020, signed and sealed by Scott Hamilton, P.E.
2. Certificate of amendment changing the company name from Clopay Building Products Company, Inc. to Clopay Corporation, issued by the State of Delaware, dated 08/27/2019.



Carlos M. Utrera, P.E.
Product Control Examiner
NOA-No. 20-0922.32
Expiration Date: July 18, 2023
Approval Date: November 25, 2020

MODELS	SHORT	LONG
CLOPAY GALLERY	GD2SP, GR2SP	GD2LP, GR2LP
HOLMES ARTISTRY	AR2SP	AR2LP
IDEAL EXPRESSIONS	ED2SP	ED2LP

MODELS	FLUSH	MINDR RIBS
CLOPAY CLASSIC	4302, HDGC	4305, HDGR
HOLMES CLASSIC	6202	6205
IDEAL CLASSIC	SFC68	SFR68

SHEET:
1 OF 3

REVISIONS					
REV. NO.	ZONE:	DATE:	ECN NO.	APPVD:	DESCRIPTION
03	-	2/2015	-	SH	ADDED CODE COMPLIANCE STATEMENT.
04	-	9/20/16	-	SH	ADDED RIBBED MODELS 4305, HDGR, 6205, SFR68
05	-	7/18/17	-	SH	UPDATED CODE COMPLIANCE STATEMENT TO ADD 6TH EDITION FBC.
06	-	8/28/20	-	SH	UPDATED TITLE BLOCK AND CODE COMPLIANCE STATEMENT TO 7TH

PRODUCT REVISED
as complying with the Florida Building Code
NOA-No. 20-0922.32
Expiration Date 07/18/2023
By *[Signature]*
Miami-Dade Product Control

THIS PRODUCT CONFORMS TO THE REQUIREMENTS OF 6TH AND 7TH EDITION OF THE FLORIDA BUILDING CODE

SECTION B-B (IMPACT-RESISTANT GLAZING OPTION)

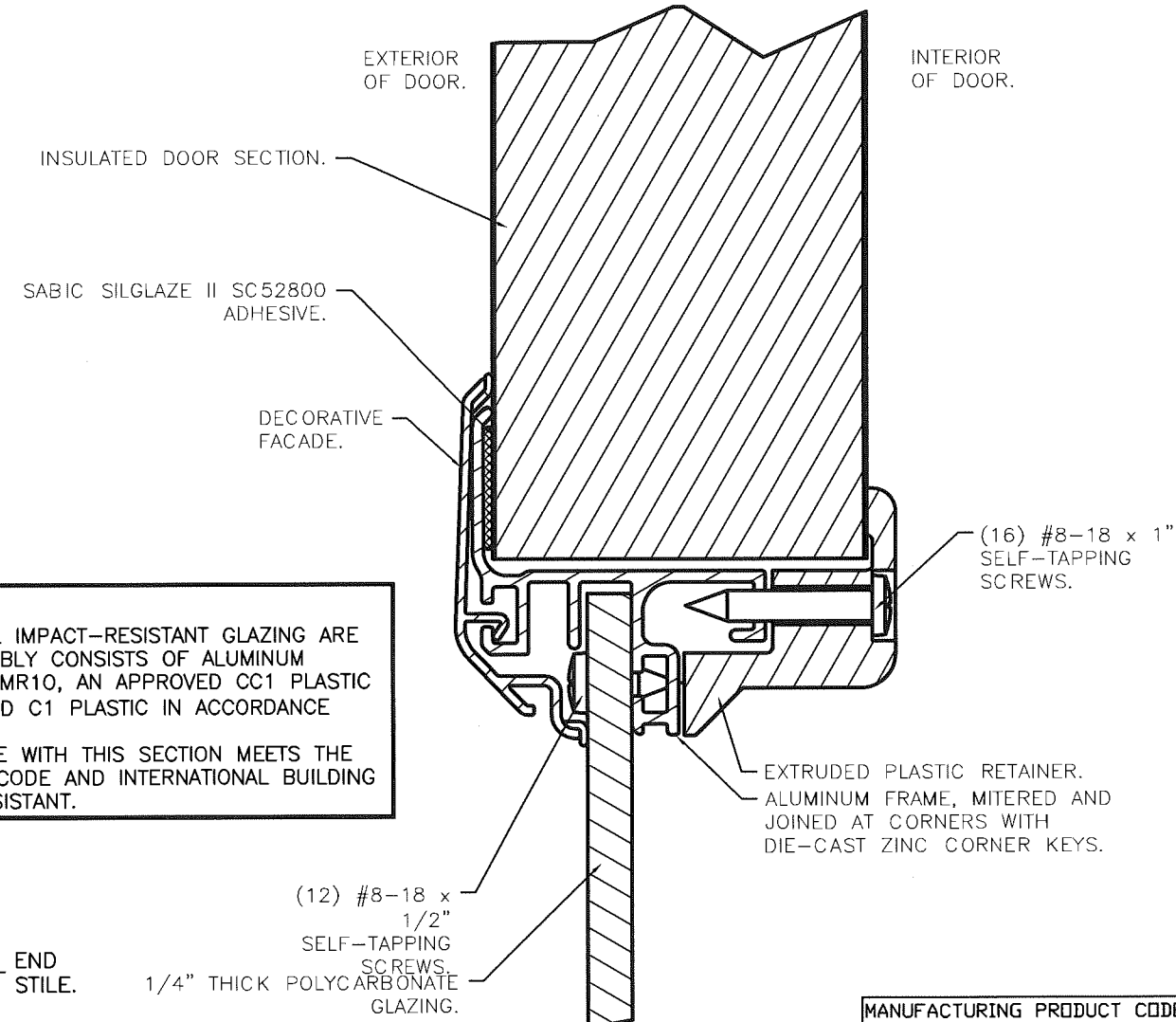
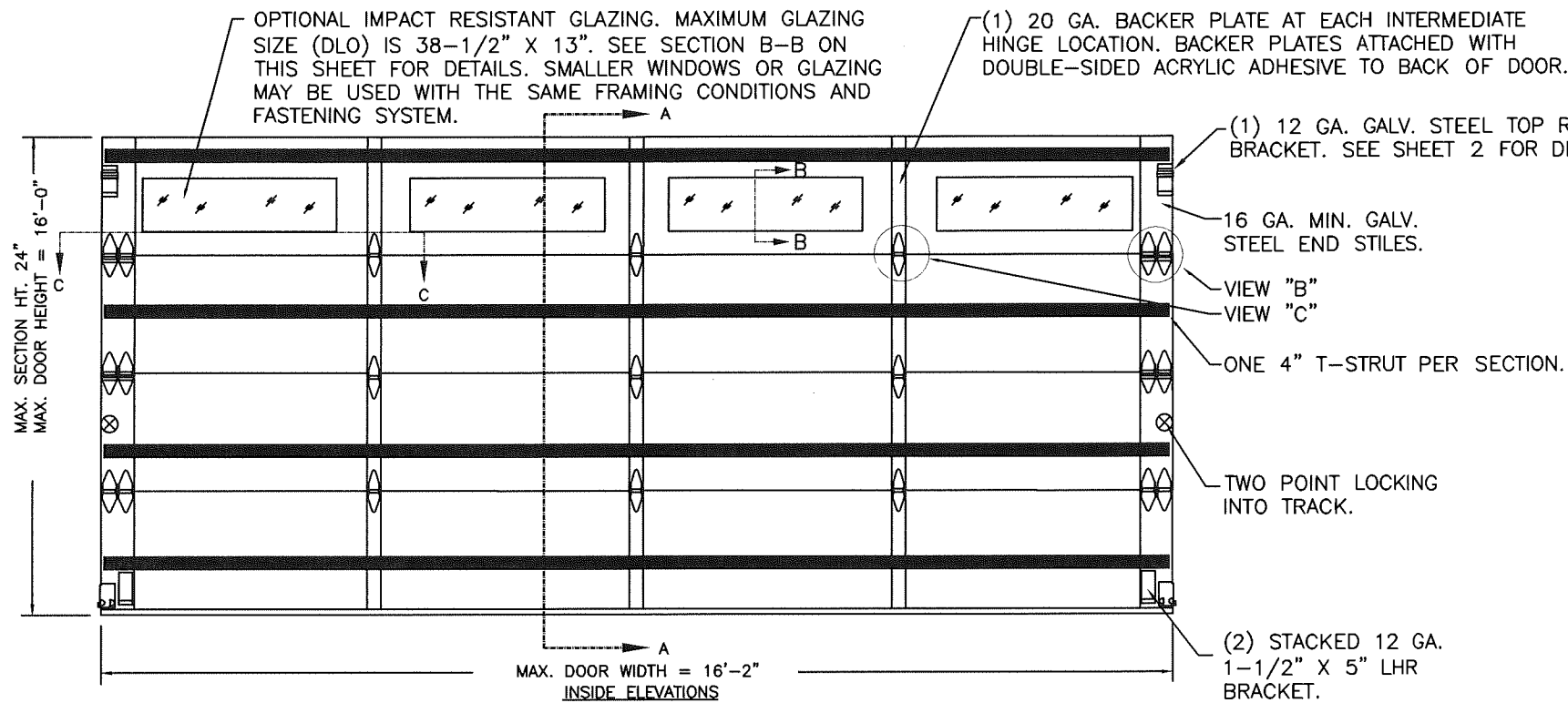

IMPACT-RESISTANT CONSTRUCTION:
SOLID DOORS (NO GLAZING) OR DOORS WITH OPTIONAL IMPACT-RESISTANT GLAZING ARE IMPACT-RESISTANT. OPTIONAL IMPACT RESISTANT ASSEMBLY CONSISTS OF ALUMINUM FRONT FRAME AND SABIC INNOVATIVE PLASTICS LEXAN MR10, AN APPROVED CC1 PLASTIC IN ACCORDANCE WITH IBC/FBC 2606 AND AN APPROVED C1 PLASTIC IN ACCORDANCE WITH FBC 2612.
THE ENTIRE DOOR ASSEMBLY INSTALLED IN COMPLIANCE WITH THIS SECTION MEETS THE WIND LOAD REQUIREMENTS OF THE FLORIDA BUILDING CODE AND INTERNATIONAL BUILDING CODE AND IS LARGE- AND SMALL-MISSILE IMPACT RESISTANT.

DOOR HEIGHT	# OF SECTIONS
UP TO 8'0"	4
8'3" TO 10'0"	5
10'3" TO 12'0"	6
12'3" TO 14'0"	7
14'3" TO 16'0"	8
MAX SECTION HEIGHT: 24'	

DESIGN LOADS: +38.0 P.S.F. & -42.0 P.S.F.

Unless Stated Otherwise TOLERANCES are
.0 = ±.031
.00 = ±.015
.000 = ±.005
.0000 = ±.001
Degrees = ±1/2"
Unless Stated Otherwise DIMENSIONS ARE IN INCHES.

Clopay CORPORATION
8585 Duke Boulevard
Mason, OH 45040 USA
Tel. No. 513-770-4800
Fax No. 513-770-4853

MANUFACTURING PRODUCT CODE
DSIE-1F471

PART NO.: N/A

WINDLOAD RATING
W6 DP38T

DESCRIPTION: 2" GALLERY EPS DOORS 16'2"W (SEE TABLE)
DRAWN BY: SH DATE: 1/10/13 SCALE: NTS DWG. B
CHECKED BY: SH DATE: 1/10/13 SHEET 1 OF 3 SIZE B
DWG. NO.: 104785 VER: MD

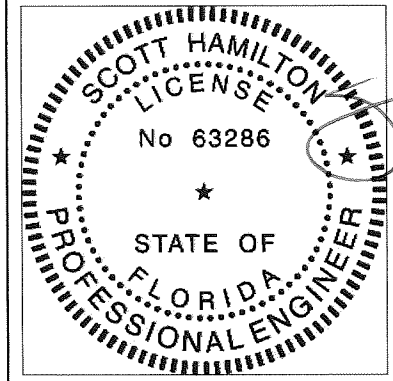

DESIGN ENGINEER:
SCOTT HAMILTON, P.E.
FLORIDA LICENSE No. 63286

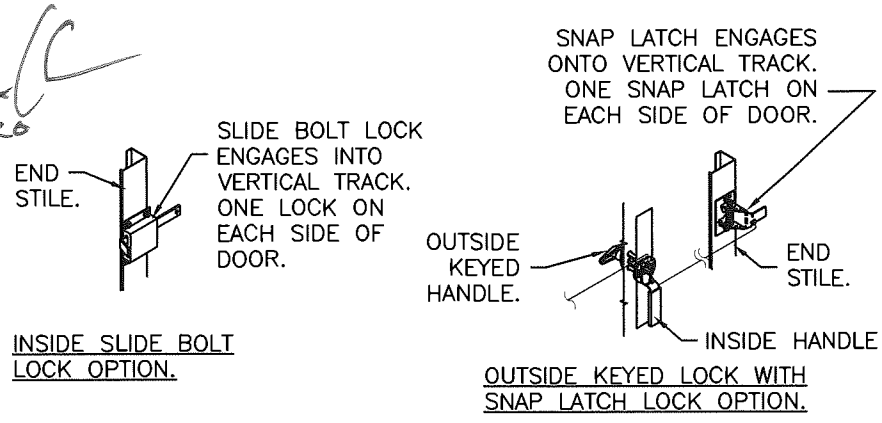

MODELS	SHORT	LONG
CLOPAY GALLERY	GD2SP, GR2SP	GD2LP, GR2LP
HOLMES ARTISTRY IDEAL EXPRESSIONS	AR2SP	AR2LP
	ED2SP	ED2LP

MODELS	FLUSH	MINOR RIBS
CLOPAY CLASSIC	4302, HDGC	4305, HDGR
HOLMES CLASSIC	6202	6205
IDEAL CLASSIC	SFC68	SFR68

SHEET: 2 OF 3

REVISIONS					
REV. NO.	ZONE	DATE	ECN NO.	APPVD:	DESCRIPTION
06	-	-	-	SH	SEE REVISION HISTORY ON SHEET ONE.

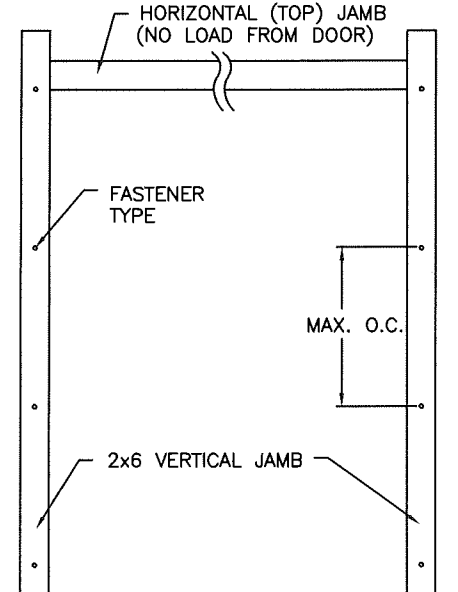

JAMB TO SUPPORTING STRUCTURE ATTACHMENT

- NOTES:**
- ALL THE LOAD FROM THE DOOR IS TRANSFERRED TO THE TRACK AND THEN FROM THE TRACK TO THE 2x6 VERTICAL SYP (GRADE #2 OR BETTER) JAMBS. NO LOAD FROM THE DOOR IS TRANSFERRED TO THE HORIZONTAL (TOP) JAMB.
 - EACH VERTICAL JAMB SEES A MAXIMUM DESIGN LOAD OF +304 LB & -336 LB. PER LINEAR FOOT OF JAMB.
 - ALL JAMB FASTENERS MAY BE (BUT ARE NOT REQUIRED TO BE) COUNTERSUNK TO PROVIDE A FLUSH MOUNTING SURFACE.
 - A 1/3 STRESS INCREASE FOR WIND LOAD WAS NOT USED IN THE CALCULATION OF ALLOWABLE LOADS FOR ANCHORS AND FASTENERS FOR STEEL, CONCRETE AND MASONRY.

2x6 JAMB TO SUPPORTING STRUCTURE ATTACHMENT
(NOT TO BE USED FOR ATTACHMENT OF TRACK ANGLE TO 2x6 VERTICAL JAMBS OR SUPPORTING STRUCTURE)

BUILDING TYPE	FASTENER TYPE	MAXIMUM ON-CENTER DISTANCE BETWEEN FASTENERS*	STEEL WASHERS REQUIRED?
HOLLOW CMU BLOCK WALL	1/4" x 1-1/4" MIN. EMBED ULTRACON CONCRETE ANCHOR	5-1/2"	1" O.D.
GROUT-FILLED CMU BLOCK	1/4" x 1-3/4" MIN. EMBED ULTRACON CONCRETE ANCHOR	9"	1" O.D.
2000 PSI MIN. CONCRETE	1/4" x 1" MIN. EMBED ULTRACON CONCRETE ANCHOR	7-3/4"	1" O.D.
2000 PSI MIN. CONCRETE	1/4" x 1" MIN. EMBED TAPCON CONCRETE ANCHOR	4-1/2"	1" O.D.
2000 PSI MIN. CONCRETE	3/8" x 1-3/4" MIN. EMBED WEJ-IT ANKR TITE SLEEVE ANCHOR	16-1/2"	INCLUDED
4000 PSI MIN. CONCRETE	3/8" x 1-3/4" MIN. EMBED WEJ-IT ANKR TITE SLEEVE ANCHOR	24"	INCLUDED
WOOD FRAME (SYP 0.55 SG)	1/2" x 3" LAG SCREW (ASTM A307, GRADE A) 1-5/8" EMBED INTO STRUCTURE	17-3/4"	1" O.D.

* FIRST (BOTTOM) ANCHOR STARTING AT NO MORE THAN HALF OF THE MAXIMUM ON-CENTER DISTANCE. HIGHEST ANCHOR INSTALLED AT LEAST AS HIGH AS THE DOOR OPENING.
CLOPAY DOES NOT SUPPLY JAMB ATTACHMENT FASTENERS.
MINIMUM DISTANCE BETWEEN CENTER OF ANCHOR AND EDGE OF CONCRETE BLOCK: 2-1/2", EXCLUDING STUCCO THICKNESS.

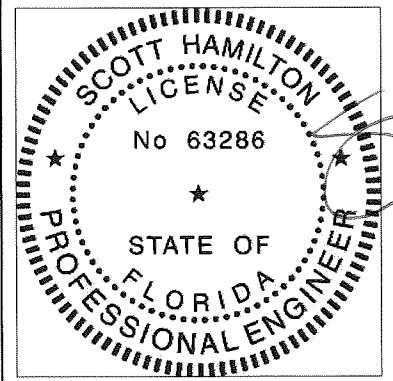

DESIGN ENGINEER:
SCOTT HAMILTON, P.E.
FLORIDA LICENSE No. 63286

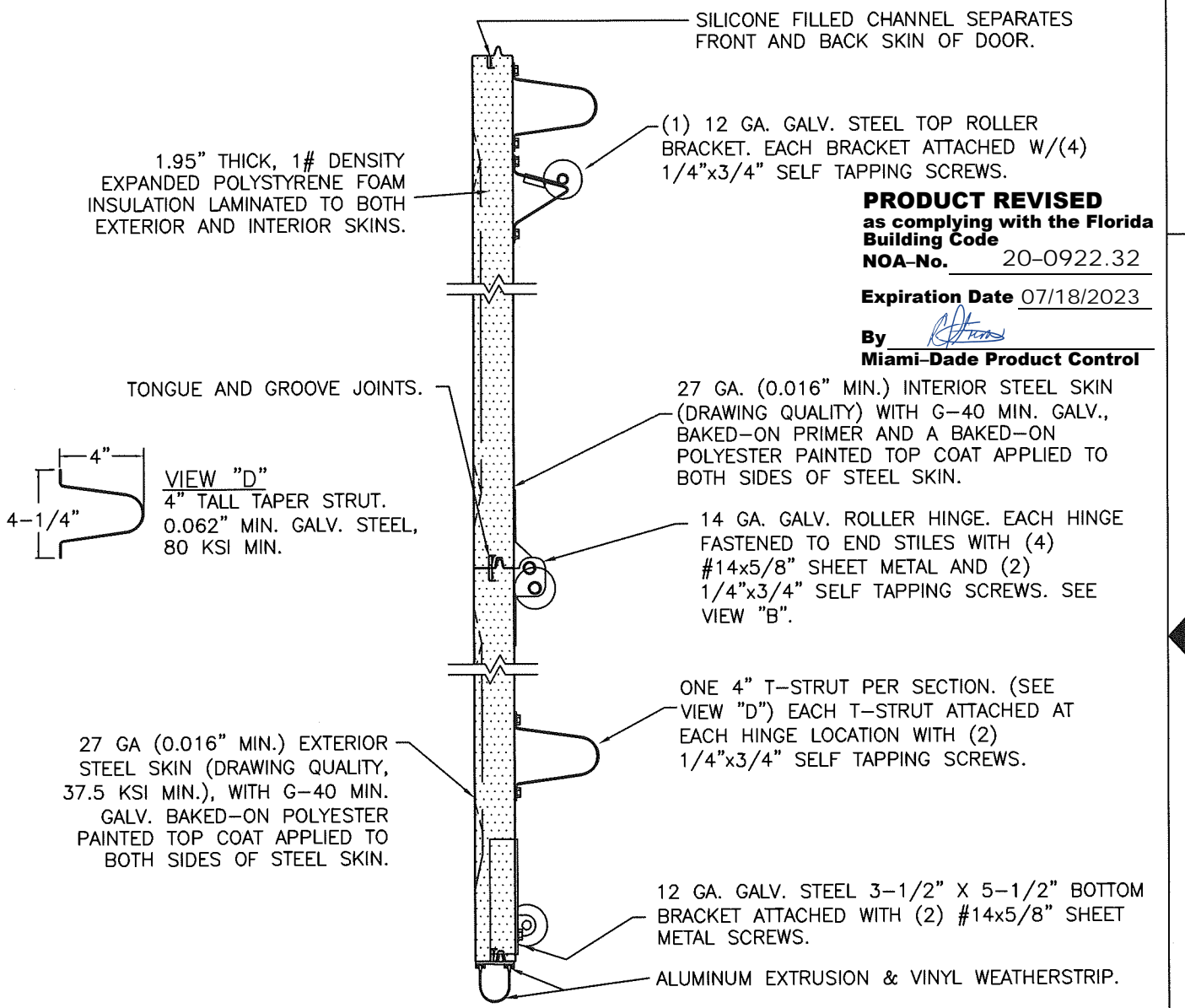
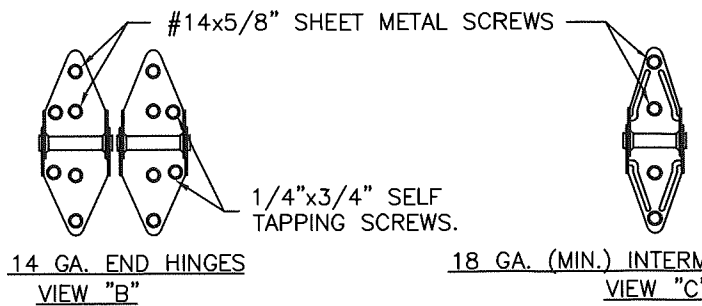

SECTION A-A (SIDE VIEW)

DESIGN LOADS: +38.0 P.S.F. & -42.0 P.S.F.

Unless Stated Otherwise TOLERANCES are

.0	= ±.031
.00	= ±.015
.000	= ±.005
.0000	= ±.001
Degrees	= ±1/2°

Unless Stated Otherwise DIMENSIONS ARE IN INCHES.

Clopay CORPORATION
8585 Duke Boulevard
Mason, OH 45040 USA
Tel. No. 513-770-4800
Fax No. 513-770-4853

MANUFACTURING PRODUCT CODE
DSIE-1F471

PART NO.: N/A

WINDLOAD RATING
W6 DP38T

DESCRIPTION: 2" GALLERY EPS DOORS 16'2"W (SEE TABLE)	SCALE: NTS	DWG. B
DRAWN BY: SH	DATE: 1/10/13	SHEET 2 OF 3
CHECKED BY: SH	DATE: 1/10/13	SIZE B
DWG. NO.: 104785	VER: MD	

MODELS	SHORT	LONG
CLOPAY GALLERY	GD2SP, GR2SP	GD2LP, GR2LP
HOLMES ARTISTRY	AR2SP	AR2LP
IDEAL EXPRESSIONS	ED2SP	ED2LP

MODELS	FLUSH	MINDR RIBS
CLOPAY CLASSIC	4302, HDGC	4305, HDGR
HOLMES CLASSIC	6202	6205
IDEAL CLASSIC	SFC68	SFR68

SHEET: 3 OF 3

REVISIONS					
REV. NO.	ZONE:	DATE:	ECN NO.	APPVD:	DESCRIPTION
06	-	-	-	SH	SEE REVISION HISTORY ON SHEET ONE.

PRODUCT REVISED
as complying with the Florida Building Code
NOA-No. 20-0922.32
Expiration Date 07/18/2023
By *[Signature]*
Miami-Dade Product Control

2" TRACK CONFIGURATION
DOORS UP TO 800 LBS.

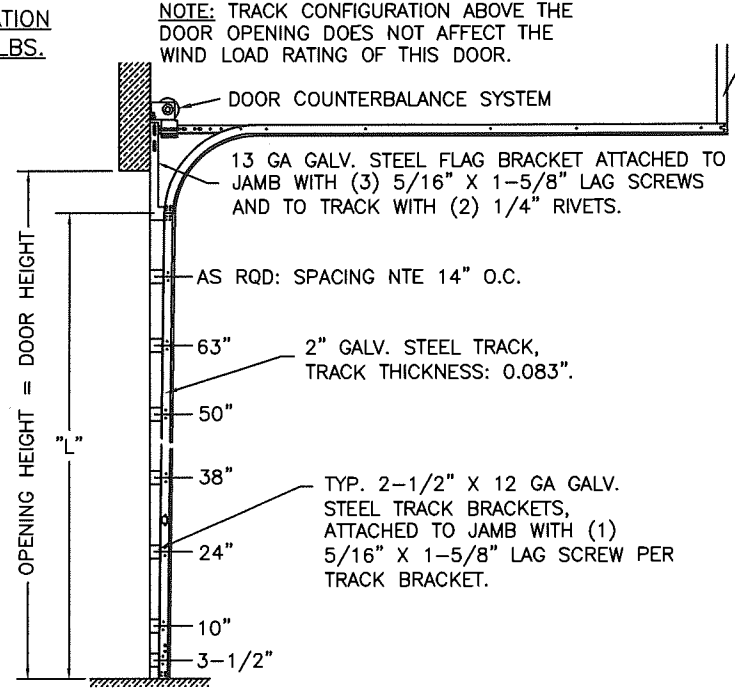

HORIZONTAL TRACK SUPPORT BY DOOR INSTALLER (TO SUIT).

DOOR HEIGHT	"L"
6'-6"	70"
7'-0"	76"
7'-6"	82"
8'-0"	88"
8'-6"	94"
9'-0"	100"
9'-6"	106"
10'-0"	112"
10'-6"	118"
11'-0"	124"
11'-6"	130"
12'-0"	136"
12'-6"	142"
13'-0"	148"
13'-6"	154"
14'-0"	160"
14'-6"	166"
15'-0"	172"
15'-6"	178"
16'-0"	184"

JAMB CONFIGURATION
DOORS UP TO 800 LBS.

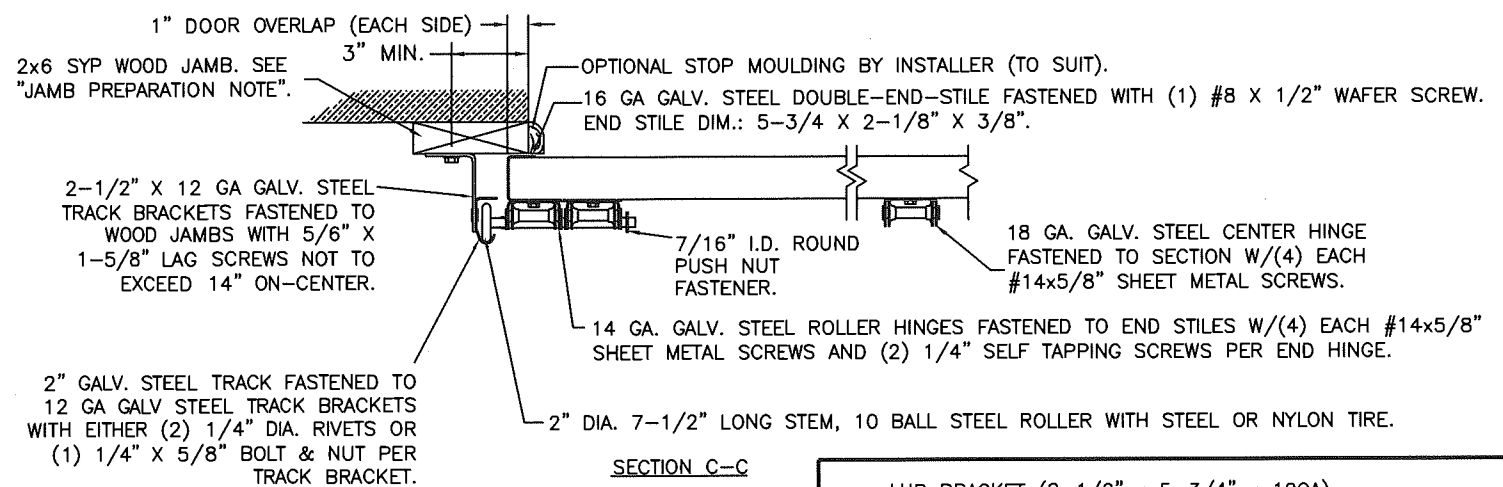

SECTION C-C

PREPARATION OF JAMBS BY OTHERS.

LHR BRACKET (2-1/2" x 5-3/4" x 12GA) ATTACHED WITH (2) 1/4" x 3/4" SELF TAPPING SCREWS. NOTE THAT LHR BRACKETS ARE ALSO USED WITH "DOUBLE END STILE" AS SHOWN IN ZONE B-3 SHEET 1.

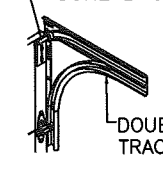

DOUBLE TRACK LOW HEADROOM OPTION (AVAIL. FOR BOTH 2" AND 3" TRACK)

3" TRACK CONFIGURATION
DOORS 800 LBS AND OVER.

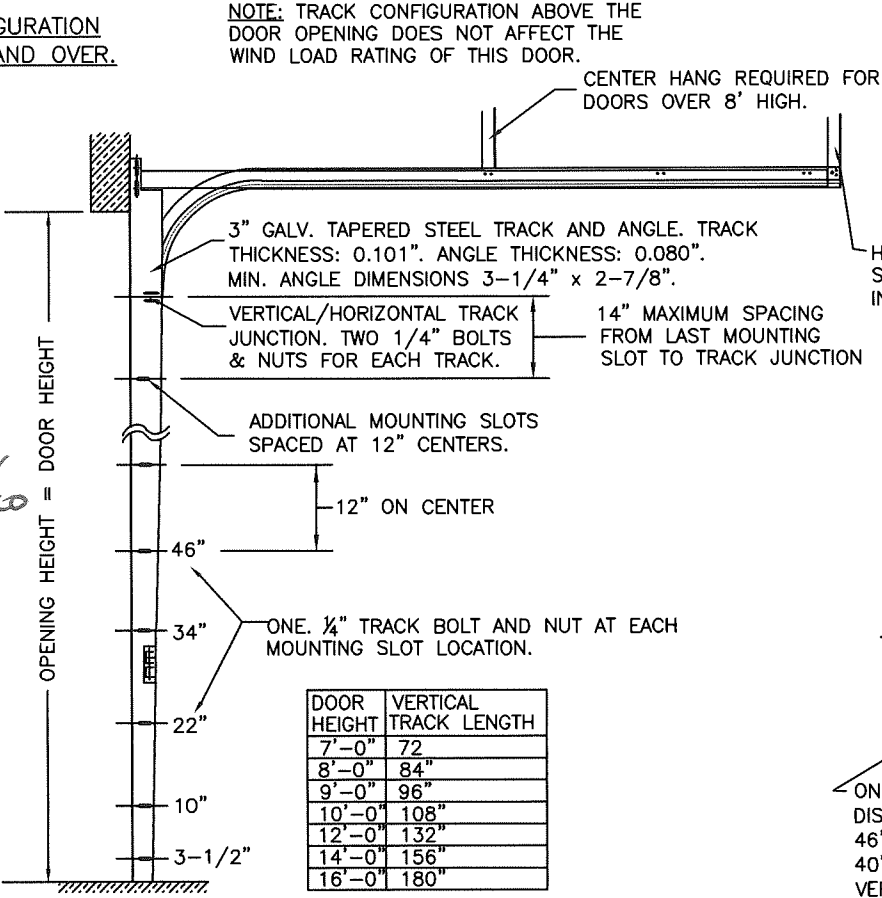

JAMB CONFIGURATION
DOORS 800 LBS AND OVER.

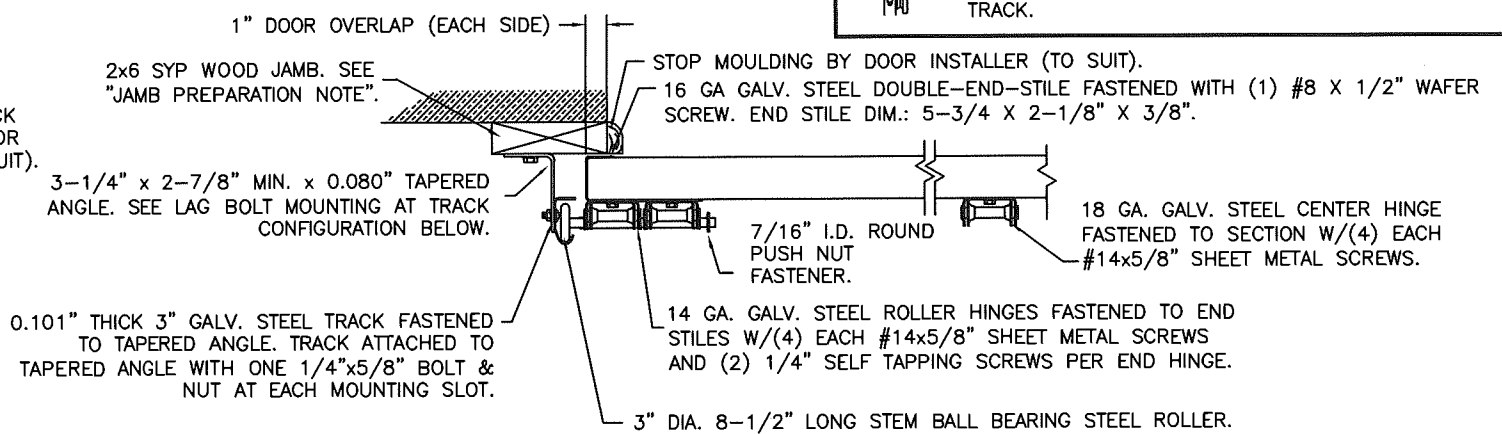

SECTION C-C

PREPARATION OF JAMBS BY OTHERS.

DESIGN LOADS: +38.0 P.S.F. & -42.0 P.S.F.

Unless Stated Otherwise TOLERANCES are

.0	= ±.031
.00	= ±.015
.000	= ±.005
.0000	= ±.001
Degrees	= ±1/2°

Unless Stated Otherwise DIMENSIONS ARE IN INCHES.

Clopay CORPORATION
8585 Duke Boulevard
Mason, OH 45040 USA
Tel. No. 513-770-4800
Fax No. 513-770-4853

MANUFACTURING PRODUCT CODE
DSIE-1F471

PART NO.: N/A

WINDLOAD RATING
W6 DP38T

DESCRIPTION: 2" GALLERY EPS DOORS 16'2"W (SEE TABLE)			
DRAWN BY: SH	DATE: 1/10/13	SCALE: NTS	DWG. B
CHECKED BY: SH	DATE: 1/10/13	SHEET 3 OF 3	SIZE B
DWG. NO.: 104785		VER: MD	

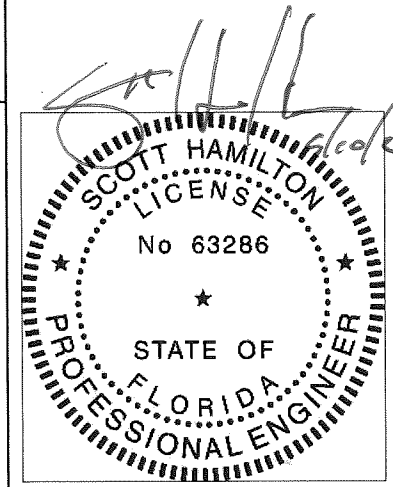

DESIGN ENGINEER:
SCOTT HAMILTON, P.E.
FLORIDA LICENSE No. 63286