



**MIAMI-DADE COUNTY
PRODUCT CONTROL SECTION**

11805 SW 26 Street, Room 208
Miami, Florida 33175-2474
T (786) 315-2590 F (786) 315-2599

**DEPARTMENT OF REGULATORY AND ECONOMIC RESOURCES (RER)
BOARD AND CODE ADMINISTRATION DIVISION**

www.miamidade.gov/economy

NOTICE OF ACCEPTANCE (NOA)

**Clopay Building Products Company
8585 Duke Boulevard
Mason, OH 45040**

SCOPE:

This NOA is being issued under the applicable rules and regulations governing the use of construction materials. The documentation submitted has been reviewed and accepted by Miami-Dade County RER-Product Control Section to be used in Miami Dade County and other areas where allowed by the Authority Having Jurisdiction (AHJ).

This NOA shall not be valid after the expiration date stated below. The Miami-Dade County Product Control Section (In Miami Dade County) and/or the AHJ (in areas other than Miami Dade County) reserve the right to have this product or material tested for quality assurance purposes. If this product or material fails to perform in the accepted manner, the manufacturer will incur the expense of such testing and the AHJ may immediately revoke, modify, or suspend the use of such product or material within their jurisdiction. RER reserves the right to revoke this acceptance, if it is determined by Miami-Dade County Product Control Section that this product or material fails to meet the requirements of the applicable building code.

This product is approved as described herein, and has been designed to comply with the Florida Building Code, including the High Velocity Hurricane Zone.

DESCRIPTION: Commercial 1-3/4” Intellicore Insulated W6 DP37T Steel Sectional Garage Door up to 16’-2” Wide w/ Optional Impact Resistant Lites

APPROVAL DOCUMENT: Drawing No. **104801**, titled “1-3/4” Intellicore Doors up to 16’2”W”, sheets 1 through 3 of 3, dated 05/16/2014, with revision 6 dated 08/28/20, prepared by Clopay Building Products Company, signed and sealed by Mark Westerfield, P.E., bearing the Miami-Dade County Product Control revision stamp with the Notice of Acceptance number and expiration date by the Miami-Dade County Product Control Section.

MISSILE IMPACT RATING: Large and Small Missile Impact Resistant

LABELING: A permanent label with the manufacturer’s name or logo, manufacturing address, model number, the positive and negative design pressure rating, indicate impact rated if applicable, installation instruction drawing reference number, approval number (NOA), the applicable test standards, and the statement reading ‘Miami-Dade County Product Control Approved’ is to be located on the door’s side track, bottom angle, or inner surface of a panel.

RENEWAL of this NOA shall be considered after a renewal application has been filed and there has been no change in the applicable building code negatively affecting the performance of this product.

TERMINATION of this NOA will occur after the expiration date or if there has been a revision or change in the materials, use, and/or manufacture of the product or process. Misuse of this NOA as an endorsement of any product, for sales, advertising or any other purposes shall automatically terminate this NOA. Failure to comply with any section of this NOA shall be cause for termination and removal of NOA.

ADVERTISEMENT: The NOA number preceded by the words Miami-Dade County, Florida, and followed by the expiration date may be displayed in advertising literature. If any portion of the NOA is displayed, then it shall be done in its entirety.

INSPECTION: A copy of this entire NOA shall be provided to the user by the manufacturer or its distributors and shall be available for inspection at the job site at the request of the Building Official.

This NOA **revises NOA #19-0815.02** and consists of this page 1 and evidence pages E-1 and E-2, as well as approval document mentioned above.

The submitted documentation was reviewed by **Sifang Zhao, P.E.**



S.Z.

12/17/2020

**NOA No 20-0922.41
Expiration Date: October 2, 2024
Approval Date: December 17, 2020
Page 1**

NOTICE OF ACCEPTANCE: EVIDENCE SUBMITTED

1. Evidence submitted under previous NOAs

A. DRAWINGS

1. Drawing No. **104801**, titled "1-3/4" Intellicore Doors up to 16'2"W", sheet 1 through 3 of 3, dated 05/16/2014, with revision 4 dated 2/2015, prepared by Clopay Building Products Company, signed and sealed by Mark Westerfield, P.E. "**Submitted under NOA#15-0225.28**"
2. Drawing No. **104801**, titled "1-3/4" Intellicore Doors up to 16'2"W", sheet 1 through 3 of 3, dated 05/16/2014, with revision 5 dated 07/2017, prepared by Clopay Building Products Company, signed and sealed by Mark Westerfield, P.E. "**Submitted under NOA#17-0809.16**"

B. TESTS

1. Test reports on
 - 1) Uniform Static Air Pressure Test, Loading per FBC TAS 202-94
 - 2) Large Missile Impact Test per FBC, TAS 201-94
 - 3) Cyclic Wind Pressure Loading per FBC, TAS 203-94
 - 4) Forced Entry Test, per FBC, TAS 202-94
 - 5) Tensile Test per ASTM E8Along with marked-up drawings and installation diagram of 16'2"x 8', 27ga steel garage door Model GD2LPW8 with MAK SL and/or MAK 15 windows, prepared by American Test Lab, Inc., Test Report No. **ATLNC 1105-01-13**, dated 01/14/2014, signed and sealed by David W. Johnson, P.E. "**Submitted under NOA # 14-0505.10**"
2. Test report on Salt Spray per ASTM B117 of painted G40 galvanized coated panels, prepared by Stork Materials Technology, Test Report No. **30160-04-63365**, dated 01/26/2005, signed by John D. Lee, P.E. "**Submitted under NOA # 14-0505.10**"
3. Test reports on
 - 1) Uniform Static Air Pressure Test, Loading per FBC TAS 202-94
 - 2) Large Missile Impact Test per FBC, TAS 201-94
 - 3) Cyclic Wind Pressure Loading per FBC, TAS 203-94
 - 4) Forced Entry Test, per FBC, TAS 202-94
 - 5) Tensile Test per ASTM E8Along with marked-up drawings and installation diagram of 16'2"x 8', 27ga steel garage door Model 3717W6 with Lexan MR10 windows, prepared by American Test Lab, Inc., Test Report No. **ATLNC 0604.01-13**, dated 02/25/2014, and Addendum to Test Report No. **ATLNC 0604.01-13**, dated 06/11/2014, signed and sealed by David W. Johnson, P.E. "**Submitted under NOA # 14-0724.18**"

C. CALCULATIONS

1. Jamb anchor calculations prepared by Clopay Building Products Company, dated 07/22/2014, signed and sealed by Mark Westerfield, P.E. "**Submitted under NOA # 14-0724.18**"

D. QUALITY ASSURANCE

1. Miami-Dade Department of Regulatory and Economic Resources (RER)

E. MATERIAL CERTIFICATIONS

1. Notice of Acceptance No. **15-0915.08** issued to SABIC Innovative Plastics, US LLC for their Lexan Polycarbonate Sheet Products, approved on 12/10/2015, expiring on 07/17/2018.
2. Notice of Acceptance No. **17-0410.01** issued to Covestro LLC for their Makrolon Polycarbonate Sheets, approved on 06/08/2017, expiring on 08/27/2022.



Sifang Zhao, P.E.
Product Control Examiner
NOA No 20-0922.41
Expiration Date: October 02, 2024
Approval Date: December 17, 2020

NOTICE OF ACCEPTANCE: EVIDENCE SUBMITTED

E. MATERIAL CERTIFICATIONS (CONTINUED)

3. Test report on Surface Burning Characteristics, per ASTM E84 of the polyurethane, Test Report No. **100585112SAT-001A**, prepared by Intertek Testing Services, NA, Inc., dated 12/13/2011, signed by Servando Romo.

F. STATEMENTS

1. Statement letters of code conformance to 2010 FBC and no financial interest, both issued by Clipay Building Products Company, dated 07/22/2014, signed and sealed by Mark Westerfield, P.E. *“Submitted under NOA # 14-0724.18”*
2. Statement letter of code conformance with the 2010 and the 5th edition (2014) FBC issued by Clipay Building Products Company, dated 02/18/2015, signed and sealed by Mark Westerfield, P.E. *“Submitted under NOA # 15-0225.28”*
3. Statement letters of code conformance to the 6th Edition (2017) FBC and of no financial interest issued by Clipay Building Products Company, dated 08/08/2019, signed and sealed by Mark Westerfield, P.E. *“Submitted under NOA#17-0809.16”*

2. New evidence submitted

A. DRAWINGS

1. Drawing No. **104801**, titled “1-3/4” Intellicore Doors up to 16’2”W”, sheet 1 through 3 of 3, dated 05/16/2014, with revision 6 dated 08/28/2020, prepared by Clipay Building Products Company, signed and sealed by Mark Westerfield, P.E.

B. TESTS

1. None.

C. CALCULATIONS

1. None.

D. QUALITY ASSURANCE

1. Miami-Dade Department of Regulatory and Economic Resources (RER)

E. MATERIAL CERTIFICATIONS

1. None.

F. STATEMENTS

1. Statement letters of code conformance to the 7th Edition (2020) FBC and of no financial interest issued by Clipay Building Products Company, dated 09/15/2020, signed and sealed by Mark Westerfield, P.E.



Sifang Zhao, P.E.
Product Control Examiner
NOA No 20-0922.41
Expiration Date: October 02, 2024
Approval Date: December 17, 2020

CLOPAY / IDEAL / HOLMES			
3717 / C7X17 / --	/ 27GA 1.75" THICK MINOR RIB		
3718 / C7X18 / --	/ 27GA 1.75" THICK FLUSH		
3720 / C7X20 / 240U	/ 27GA 2" THICK MINOR RIB		
3722 / COX22 / --	/ 20GA 2" THICK FLUSH		
3724 / C7X24 / 244U	/ 24GA 2" THICK MINOR RIB		

SHEET:
1 OF 3

REVISIONS

REV. NO.	ZONE:	DATE:	ECN NO.	APPVD:	DESCRIPTION
01	-	3/7/14	-	SH	CORRECTED TYPO ON ELEVATION VIEW.
02	-	5/16/14	-	MWW	MAT. NOTES & GLASS BITE ADDED IMPACT WINDOW CROSS SECTION
03	-	8/12/14	-	MWW	ADDED POLYURETHANE FOAM CALLOUT (PG. 2)
04	-	2/2015	-	SH	ADDED CODE COMPLIANCE STATEMENT.
05	-	7/2017	-	SH	UPDATED CODE COMPLIANCE STATEMENT TO ADD 6TH EDITION FBC.
06	-	8/28/20	-	SH	UPDATED TITLE BLOCK AND CODE COMPLIANCE STATEMENT TO 7TH

OPTIONAL GLAZING IMPACT RESISTANT GLAZING. MAXIMUM GLAZING SIZE (DLO) IS 22"x9-7/8". SEE SECTION B-B ON SHEET 1 FOR DETAILS.
GLAZING MAY BE INSTALLED IN TOP SECTION (NOT SHOWN) OR INTERMEDIATE SECTION (SHOWN).

(1) 20 GA. GALV. STEEL BACKER PLATE AT EACH INTERMEDIATE HINGE LOCATION. BACKER PLATE ATTACHED WITH DOUBLE SIDED ACRYLIC ADHESIVE TO BACK OF DOOR.

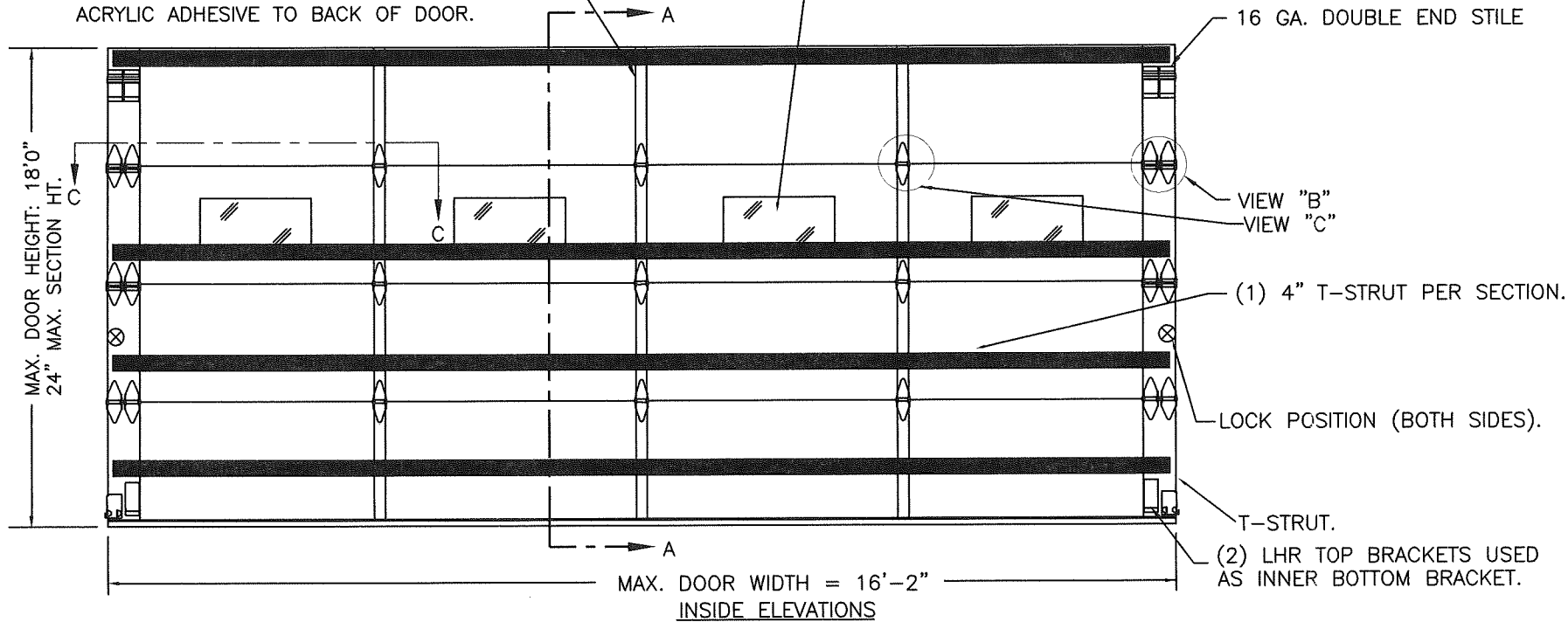

IMPACT-RESISTANT CONSTRUCTION:
SOLID DOORS (NO GLAZING) OR DOORS WITH OPTIONAL IMPACT-RESISTANT GLAZING ARE IMPACT-RESISTANT. OPTIONAL IMPACT RESISTANT ASSEMBLY CONSISTS OF ALUMINUM FRONT FRAME AND SABIC IP LEXAN 9034 (VERSIONS ALSO APPROVED: MR10, 9030, 90318, 90316, 90317, 90311, 90314, 90355) OR BAYER MAKROLON GP (VERSIONS ALSO APPROVED: SL, AR, 15), APPROVED CC1 PLASTICS IN ACCORDANCE WITH IBC/FBC 2606 AND APPROVED C1 PLASTICS IN ACCORDANCE WITH FBC 2612. THE ENTIRE DOOR ASSEMBLY INSTALLED IN COMPLIANCE WITH THIS SECTION MEETS THE WIND LOAD REQUIREMENTS OF THE FLORIDA BUILDING CODE AND INTERNATIONAL BUILDING CODE AND IS LARGE- AND SMALL- MISSILE IMPACT RESISTANT.

SECTION B-B (IMPACT-RESISTANT GLAZING OPTION)

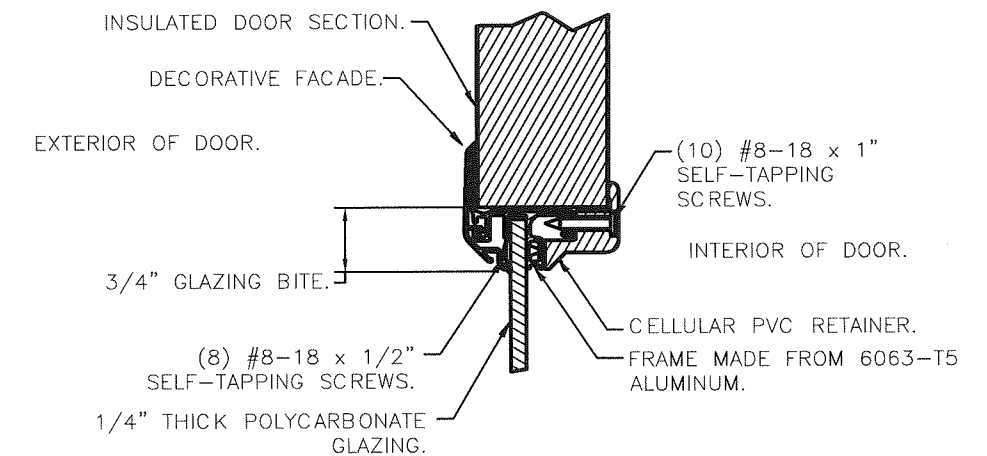

PRODUCT REVISED
as complying with the Florida Building Code
NOA-No. 20-0922.41
Expiration Date 10/02/2024
By *[Signature]*
Miami-Dade Product Control

DOOR HEIGHT 'A'	NUMBER OF SECTIONS
UP TO 8'-0"	4
8'-3" THRU 10'-0"	5
10'-3" THRU 12'-0"	6
12'-3" THRU 14'-0"	7
14'-3" THRU 16'-0"	8
16'-3" THRU 18'-0"	9

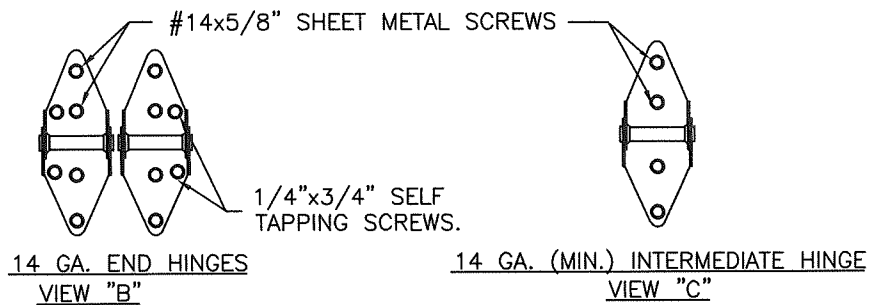

IMPACT-RESISTANT ASSEMBLY DETAILS

THIS PRODUCT CONFORMS TO THE REQUIREMENTS OF 6TH AND 7TH EDITION OF THE FLORIDA BUILDING CODE

DESIGN LOADS: +37.0 P.S.F. & -42.0 P.S.F.

MANUFACTURING PRODUCT CODE
C-DSIU-1D477

PART NO.: N/A

WINDLOAD RATING
W6 DP37T

Unless Stated Otherwise TOLERANCES are
.0 = ±.031
.00 = ±.015
.000 = ±.005
.0000 = ±.001
Degrees = ±1/2°
Unless Stated Otherwise DIMENSIONS ARE IN INCHES.

Clopay CORPORATION		8585 Duke Boulevard Mason, OH 45040 USA Tel. No. 513-770-4800 Fax No. 513-770-4853	
DESCRIPTION: 1-3/4" INTELICORE DOORS UP TO 16'2"W (SEE TABLE)			
DRAWN BY: SH	DATE: 1/10/13	SCALE: NTS	DWG. SIZE B
CHECKED BY: MWW	DATE: 5/16/14	SHEET 1 OF 3	
DWG. NO.: 104801		VER: M-D	

DESIGN ENGINEER:
MARK WESTERFIELD, P.E.
FLORIDA P.E. #48495

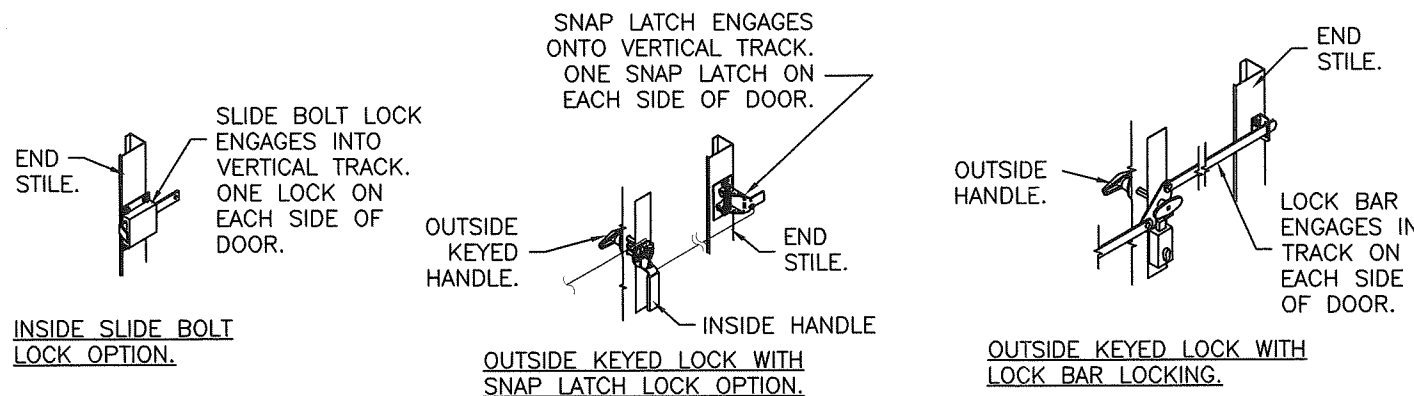

CLOPAY / IDEAL / HOLMES

- 3717 / C7X17 / -- / 27GA 1.75" THICK MINOR RIB
- 3718 / C7X18 / -- / 27GA 1.75" THICK FLUSH
- 3720 / C7X20 / 240U / 27GA 2" THICK MINOR RIB
- 3722 / COX22 / -- / 20GA 2" THICK FLUSH
- 3724 / C7X24 / 244U / 24GA 2" THICK MINOR RIB

SHEET: 2 OF 3

REVISIONS

REV. NO.	ZONE:	DATE:	ECN NO.	APPVD:	DESCRIPTION
06	-	-	-	-	SEE REVISION HISTORY ON SHEET ONE.

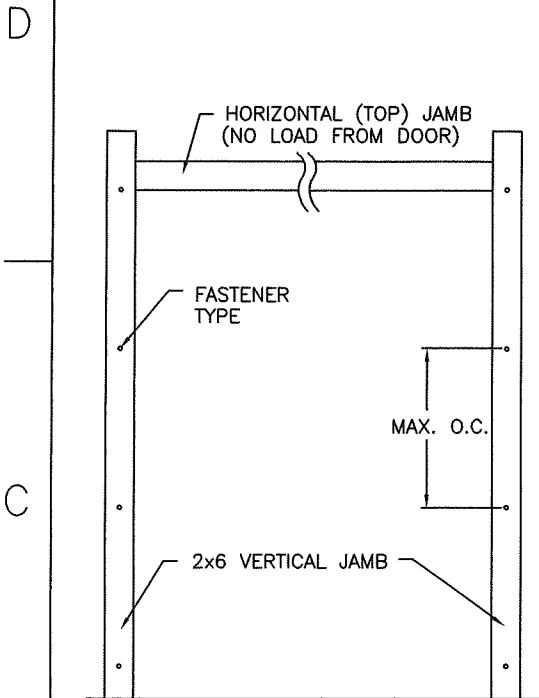

JAMB TO SUPPORTING STRUCTURE ATTACHMENT

NOTES:

1. ALL THE LOAD FROM THE DOOR IS TRANSFERRED TO THE TRACK AND THEN FROM THE TRACK TO THE 2x6 VERTICAL SYP (GRADE #2 OR BETTER) JAMBS. NO LOAD FROM THE DOOR IS TRANSFERRED TO THE HORIZONTAL (TOP) JAMB.
2. EACH VERTICAL JAMB SEES A MAXIMUM DESIGN LOAD OF +296 LB & -336 LB. PER LINEAR FOOT OF JAMB.
3. ALL JAMB FASTENERS MAY BE (BUT ARE NOT REQUIRED TO BE) COUNTERSUNK TO PROVIDE A FLUSH MOUNTING SURFACE.
4. A 1/3 STRESS INCREASE FOR WIND LOAD WAS NOT USED IN THE CALCULATION OF ALLOWABLE LOADS FOR ANCHORS AND FASTENERS FOR STEEL, CONCRETE AND MASONRY.

NOTE: 2x6 WOOD JAMBS ARE NOT REQUIRED WITH CONTINUOUS ANGLE MOUNT TRACK. HOWEVER, IF DESIRED ON STEEL JAMBS OR CONCRETE OR BLOCK WALLS, APPROVED FASTENERS AS DETAILED BELOW SHOULD BE INCREASED IN LENGTH BY 1-1/2" AND INSTALLED DIRECTLY THROUGH THE ANGLE AND 2x6 WOOD JAMBS INTO THE STEEL JAMBS OR CONCRETE OR BLOCK WALLS. ANCHORS CAN BE (BUT ARE NOT REQUIRED TO BE) COUNTERSUNK TO PROVIDE A FLUSH MOUNTING SURFACE. CONTINUOUS ANGLE TRACK CAN BE ANCHORED DIRECTLY TO GROUT REINFORCED BLOCK WALL OR 3,000 PSI MIN. CONCRETE COLUMN OR STEEL JAMBS.

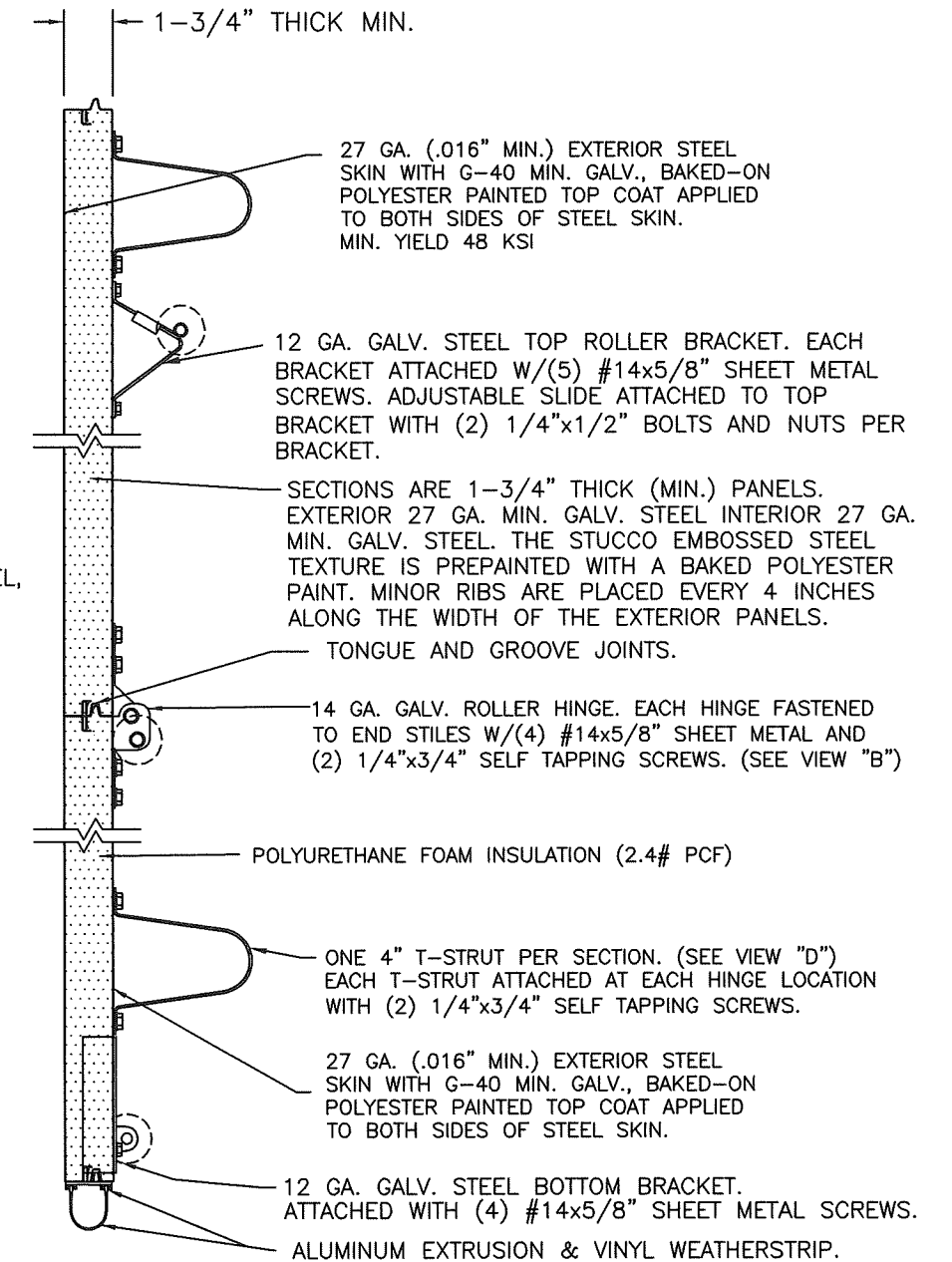
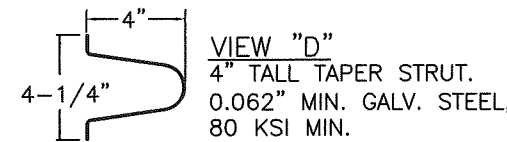

SECTION A-A (SIDE VIEW)

PRODUCT REVISED as complying with the Florida Building Code

NOA-No. 20-0922.41

Expiration Date 10/02/2024

By Miami-Dade Product Control

FASTENER ATTACHMENT TO SUPPORTING STRUCTURE SCHEDULES

BUILDING TYPE	FASTENER TYPE	MAXIMUM ON-CENTER DISTANCE BETWEEN FASTENERS*	STEEL WASHERS REQUIRED?
HOLLOW BLOCK WALL	1/4" x 1-1/4" MIN. EMBED ULTRACON CONCRETE ANCHOR	5-1/2"	1" O.D.
GROUT FILLED BLOCK WALL	1/4" x 1-3/4" MIN. EMBED ULTRACON CONCRETE ANCHOR	9-1/4"	1" O.D.
2000 PSI MIN. CONCRETE	1/4" x 1" MIN. EMBED ULTRACON CONCRETE ANCHOR	8"	1" O.D.
2000 PSI MIN. CONCRETE	1/4" x 1" MIN. EMBED TAPCON CONCRETE ANCHOR	6-3/4"	1" O.D.
2000 PSI MIN. CONCRETE	3/8" x 1-3/4" MIN. EMBED WEJ-IT ANKR TITE SLEEVE ANCHOR	17"	INCLUDED
4000 PSI MIN. CONCRETE	3/8" x 1-3/4" MIN. EMBED WEJ-IT ANKR TITE SLEEVE ANCHOR	24"	INCLUDED
WOOD FRAME (SYP 0.55 SG)	1/2" x 3" LAG SCREW (ASTM A307, GRADE A) 1-5/8" EMBED INTO STRUCTURE	18-1/4"	1" O.D.
14GA STEEL (0.060" MIN.)	1/4"-14 x 1" ITW BUILDEX TEKS SELF-DRILLING FASTENER	7-1/2"	1" O.D.
12GA STEEL (0.105" MIN.)	1/4"-14 x 1" ITW BUILDEX TEKS SELF-DRILLING FASTENER	13-1/2"	1" O.D.
1/8" STEEL	1/4"-14 x 1" ITW BUILDEX TEKS SELF-DRILLING FASTENER	16"	1" O.D.

* FIRST (BOTTOM) ANCHOR STARTING AT NO MORE THAN HALF OF THE MAXIMUM ON-CENTER DISTANCE. HIGHEST ANCHOR INSTALLED AT LEAST AS HIGH AS THE DOOR OPENING.
 CLOPAY DOES NOT SUPPLY JAMB ATTACHMENT FASTENERS.
 MINIMUM DISTANCE BETWEEN CENTER OF ANCHOR AND EDGE OF CONCRETE BLOCK: 2-1/2", EXCLUDING STUCCO THICKNESS.

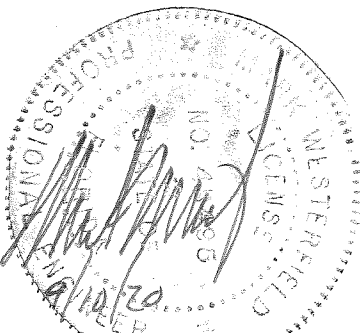

DESIGN ENGINEER, MARK WESTERFIELD, P.E. FLORIDA P.E. #48495

DESIGN LOADS: +37.0 P.S.F. & -42.0 P.S.F.

Unless Stated Otherwise TOLERANCES are
 .0 = ±.031
 .00 = ±.015
 .000 = ±.005
 .0000 = ±.001
 Degrees = ±1/2"
 Unless Stated Otherwise DIMENSIONS ARE IN INCHES.



8585 Duke Boulevard
 Mason, OH 45040 USA
 Tel. No. 513-770-4800
 Fax No. 513-770-4853

MANUFACTURING PRODUCT CODE C-DSIU-1D477

PART NO.: N/A

WINDLOAD RATING W6 DP37T

DESCRIPTION: 1-3/4" INTELLICORE DOORS UP TO 16'2"W (SEE TABLE)

DRAWN BY: SH	DATE: 1/10/13	SCALE: NTS	DWG. SIZE B
CHECKED BY: MWW	DATE: 5/16/14	SHEET 2 OF 3	

DWG. NO.: 104801 VER: M-D

CLOPAY / IDEAL / HOLMES

3717	/	C7X17	/	--	/	27GA	1.75"	THICK	MINOR	RIB
3718	/	C7X18	/	--	/	27GA	1.75"	THICK	FLUSH	
3720	/	C7X20	/	240U	/	27GA	2"	THICK	MINOR	RIB
3722	/	COX22	/	--	/	20GA	2"	THICK	FLUSH	
3724	/	C7X24	/	244U	/	24GA	2"	THICK	MINOR	RIB

SHEET:		REVISIONS					
3 OF 3		REV. NO.	ZONE:	DATE:	ECN NO.	APPVD:	DESCRIPTION
		06	-	-	-	-	SEE REVISION HISTORY ON SHEET ONE.

2" TRACK CONFIGURATION
DOORS UP TO 800 LBS.

NOTE DOUBLE TRACK HEADROOM, HI-LIFT TRACK, FOLLOW-THE-ROOF TRACK, AND VERTICAL LIFT TRACK ARE AVAILABLE OPTIONS. TRACK CONFIGURATION ABOVE THE DOOR OPENING DOES NOT AFFECT THE WIND LOAD RATING.

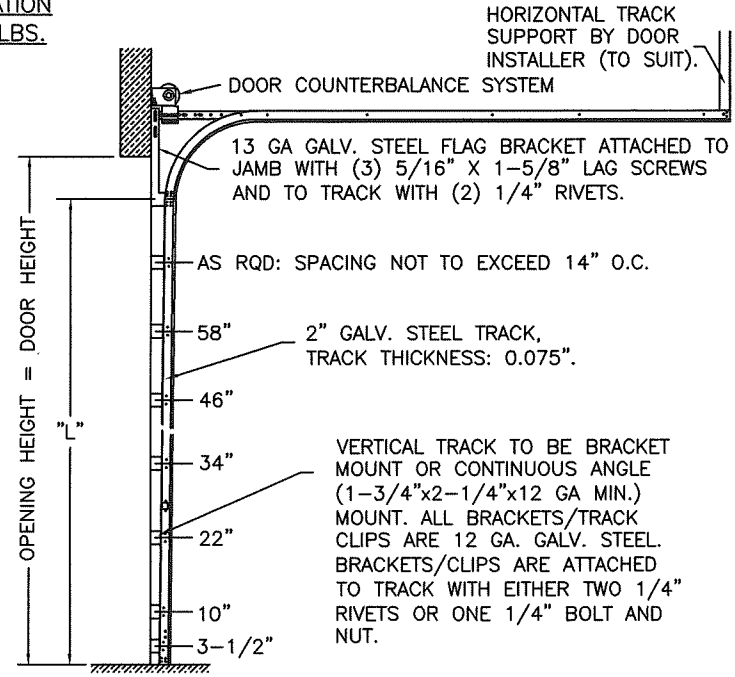

DOOR HEIGHT	"L"
6'-6"	70"
7'-0"	76"
7'-6"	82"
8'-0"	88"
8'-6"	94"
9'-0"	100"
9'-6"	106"
10'-0"	112"
10'-6"	118"
11'-0"	124"
11'-6"	130"
12'-0"	136"
12'-6"	142"
13'-0"	148"
13'-6"	154"
14'-0"	160"
14'-6"	166"
15'-0"	172"
15'-6"	178"
16'-0"	184"
16'-6"	190"
17'-0"	196"
17'-6"	202"
18'-0"	208"

JAMB CONFIGURATION
DOORS UP TO 800 LBS.

BRACKET MOUNT JAMB CONFIGURATION

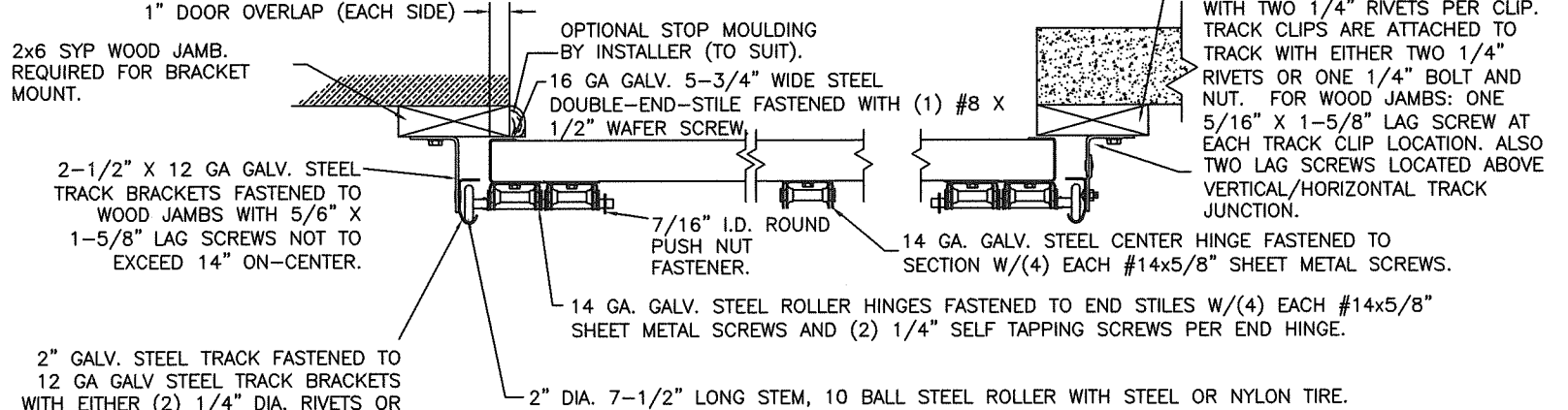

ANGLE MOUNT JAMB CONFIGURATION

2x6 SYP JAMB (IF PRESENT; SEE JAMB NOTES ON SHEET 2).

VERTICAL TRACK TO BE CONTINUOUS OR REVERSE ANGLE. 12 GA. TRACK CLIPS ATTACHED TO WALL ANGLE WITH TWO 1/4" RIVETS PER CLIP. TRACK CLIPS ARE ATTACHED TO TRACK WITH EITHER TWO 1/4" RIVETS OR ONE 1/4" BOLT AND NUT. FOR WOOD JAMBS: ONE 5/16" X 1-5/8" LAG SCREW AT EACH TRACK CLIP LOCATION. ALSO TWO LAG SCREWS LOCATED ABOVE VERTICAL/HORIZONTAL TRACK JUNCTION.

3" TRACK CONFIGURATION
DOORS 800 LBS AND OVER.

NOTE DOUBLE TRACK HEADROOM, HI-LIFT TRACK, FOLLOW-THE-ROOF TRACK, AND VERTICAL LIFT TRACK ARE AVAILABLE OPTIONS. TRACK CONFIGURATION ABOVE THE DOOR OPENING DOES NOT AFFECT THE WIND LOAD RATING.

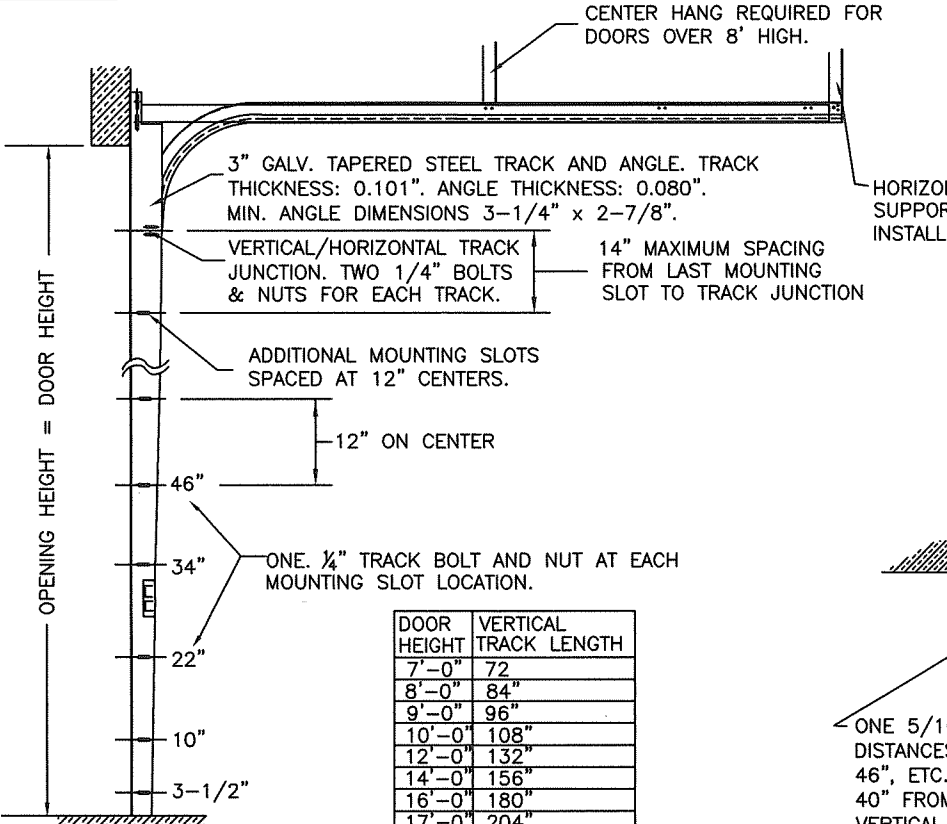

DOOR HEIGHT	VERTICAL TRACK LENGTH
7'-0"	72"
8'-0"	84"
9'-0"	96"
10'-0"	108"
12'-0"	132"
14'-0"	156"
16'-0"	180"
17'-0"	204"
18'-0"	228"

JAMB CONFIGURATION
DOORS 800 LBS AND OVER.

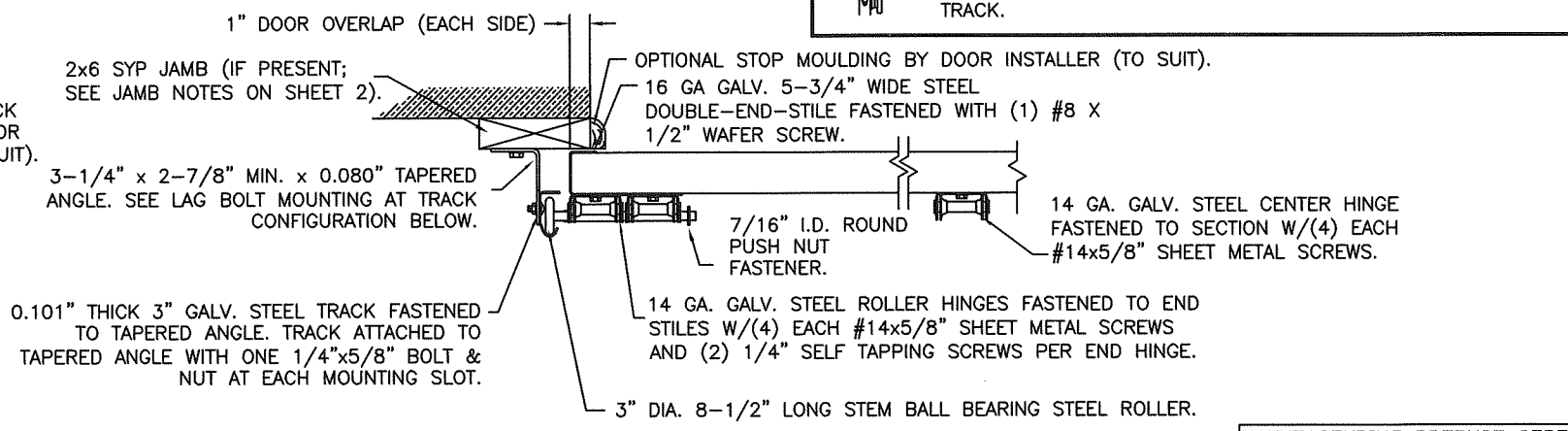

LHR BRACKET (2-1/2" x 5-3/4" x 12GA) ATTACHED WITH (2) 1/4" x 3/4" SELF TAPPING SCREWS. NOTE THAT LHR BRACKETS ARE ALSO USED WITH "DOUBLE END STILE" AS SHOWN IN ZONE B-3 SHEET 1.

DOUBLE TRACK LOW HEADROOM OPTION
(AVAIL. FOR BOTH 2" AND 3" TRACK)

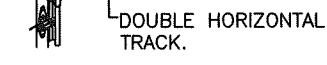

PRODUCT REVISED
as complying with the Florida Building Code
NOA-No. 20-0922.41
Expiration Date 10/02/2024
By *[Signature]*
Miami-Dade Product Control

[Signature]
DESIGN ENGINEER:
MARK WESTERFIELD, P.E.
FLORIDA P.E. #48495

DESIGN LOADS: +37.0 P.S.F. & -42.0 P.S.F.

Unless Stated Otherwise TOLERANCES are

.0	= ±.031
.00	= ±.015
.000	= ±.005
.0000	= ±.001
Degrees	= ±1/2°

Unless Stated Otherwise DIMENSIONS ARE IN INCHES.

Clopay CORPORATION
8585 Duke Boulevard
Mason, OH 45040 USA
Tel. No. 513-770-4800
Fax No. 513-770-4853

MANUFACTURING PRODUCT CODE
C-DSIU-1D477

PART NO.: N/A

WINDLOAD RATING
W6 DP37T

DESCRIPTION: 1-3/4" INTELICORE DOORS UP TO 16'2"W (SEE TABLE)			
DRAWN BY: SH	DATE: 1/10/13	SCALE: NTS	DWG. B
CHECKED BY: MWW	DATE: 5/16/14	SHEET 3 OF 3	SIZE B
DWG. NO.: 104801	VER: M-D		