



DEPARTMENT OF REGULATORY AND ECONOMIC RESOURCES (RER)
BOARD AND CODE ADMINISTRATION DIVISION

NOTICE OF ACCEPTANCE (NOA)

MIAMI-DADE COUNTY
PRODUCT CONTROL SECTION

11805 SW 26 Street, Room 208
Miami, Florida 33175-2474
T (786) 315-2590 F (786) 315-2599

www.miamidade.gov/economy

Clopay Building Products Company
8585 Duke Boulevard
Mason, OH 45040

SCOPE:

This NOA is being issued under the applicable rules and regulations governing the use of construction materials. The documentation submitted has been reviewed and accepted by Miami-Dade County RER-Product Control Section to be used in Miami Dade County and other areas where allowed by the Authority Having Jurisdiction (AHJ).

This NOA shall not be valid after the expiration date stated below. The Miami-Dade County Product Control Section (In Miami Dade County) and/or the AHJ (in areas other than Miami Dade County) reserve the right to have this product or material tested for quality assurance purposes. If this product or material fails to perform in the accepted manner, the manufacturer will incur the expense of such testing and the AHJ may immediately revoke, modify, or suspend the use of such product or material within their jurisdiction. RER reserves the right to revoke this acceptance if it is determined by Miami-Dade County Product Control Section that this product or material fails to meet the requirements of the applicable building code.

This product is approved as described herein and has been designed to comply with the Florida Building Code, including the High Velocity Hurricane Zone.

DESCRIPTION: Commercial Ribbed W6 DP36 Steel Sectional Garage Door up to 12'-2" Wide with Optional EPS Insulation

APPROVAL DOCUMENT: Drawing No. **104811**, titled "Commercial Ribbed Steel Doors up to 12'-2" W", sheets 1 through 3 of 3, dated 04/15/2015, with revision 5 dated 09/09/2020, prepared by Clopay Building Products Company, signed and sealed by Mark Westerfield, P.E., bearing the Miami-Dade County Product Control revision stamp with the Notice of Acceptance number and expiration date by the Miami-Dade County Product Control Section.

MISSILE IMPACT RATING: Large and Small Missile Impact Resistant

LABELING: A permanent label with the manufacturer's name or logo, manufacturing address, model number, the positive and negative design pressure rating, indicate impact rated if applicable, installation instruction drawing reference number, approval number (NOA), the applicable test standards, and the statement reading 'Miami-Dade County Product Control Approved' is to be located on the door's side track, bottom angle, or inner surface of a panel.

RENEWAL of this NOA shall be considered after a renewal application has been filed and there has been no change in the applicable building code negatively affecting the performance of this product.

TERMINATION of this NOA will occur after the expiration date or if there has been a revision or change in the materials, use, and/or manufacture of the product or process. Misuse of this NOA as an endorsement of any product, for sales, advertising or any other purposes shall automatically terminate this NOA. Failure to comply with any section of this NOA shall be cause for termination and removal of NOA.

ADVERTISEMENT: The NOA number preceded by the words Miami-Dade County, Florida, and followed by the expiration date may be displayed in advertising literature. If any portion of the NOA is displayed, then it shall be done in its entirety.

INSPECTION: A copy of this entire NOA shall be provided to the user by the manufacturer or its distributors and shall be available for inspection at the job site at the request of the Building Official.

This NOA **revises NOA # 20-0512.03** and consists of this page 1 and evidence pages E-1 and E-3, as well as approval document mentioned above.

The submitted documentation was reviewed by **Sifang Zhao, P.E.**



S.Z.
12/24/2020

NOA No 20-0922.53
Expiration Date: July 02, 2025
Approval Date: December 24, 2020
Page 1

Clopay Building Products Company

NOTICE OF ACCEPTANCE: EVIDENCE SUBMITTED

1. EVIDENCE SUBMITTED UNDER PREVIOUS NOAs

A. DRAWINGS

1. Drawing No. **104811**, titled "Commercial Ribbed Steel Doors up to 12'-2" W", sheets 1 through 3 of 3, dated 04/15/2015, prepared by Clopay Building Products Company, signed and sealed by Mark Westerfield, P.E. *"Submitted under NOA #15-0423.06"*
2. Drawing No. **104811**, titled "Commercial Ribbed Steel Doors up to 12'-2" W", sheets 1 through 3 of 3, dated 04/15/2015, with revision 3 dated 07/17/2017, prepared by Clopay Building Products Company, signed and sealed by Mark Westerfield, P.E. *"Submitted under NOA #17-0809.20"*

B. TESTS

1. Test reports on
 - 1) Uniform Static Air Pressure Test, Loading per FBC TAS 202-94
 - 2) Large Missile Impact Test per FBC, TAS 201-94
 - 3) Cyclic Wind Pressure Loading per FBC, TAS 203-94
 - 4) Forced Entry Test, per FBC TAS 202-94
 - 5) Tensile Test per ASTM E8along with marked-up drawings and installation diagram of Clopay Model 524, 12'-2" wide x 8' high, 24 ga. steel garage doors, prepared by American Test Lab, Inc., Test Report No. **ATLNC 1103.01-14**, dated 12/22/2014, signed and sealed by David W. Johnson, P.E. *"Submitted under NOA #15-0423.06"*
3. Test report on Salt Spray per ASTM B117 of painted G40 galvanized painted and G90 panels, prepared by Fenestration Testing Laboratory, Inc., Test Report No. **7890**, dated 10/01/2014, signed by Idalmis Ortega, P.E. *"Submitted under NOA #15-0423.06"*

C. CALCULATIONS

1. Anchoring calculations prepared by Clopay Building Products Company, dated 04/20/2015, signed and sealed by Mark Westerfield, P.E. *"Submitted under NOA #15-0423.06"*

D. QUALITY ASSURANCE

1. Miami-Dade Department of Regulatory and Economic Resources (RER)

E. MATERIAL CERTIFICATIONS

1. Test report on Ignition Properties of Plastics per ASTM D1929 of Premier Industries' Type I EPS, Report No. **3082959-500**, prepared by Intertek Testing Services, NA, Inc., dated 09/16/2005, signed by C. Anthony Peñaloza. *"Submitted under NOA #15-0423.06"*
2. Test report on Surface Burning Characteristics, per ASTM E84 of Premier Industries' Type I EPS, Report No. **3082960-500**, prepared by Intertek Testing Services, NA, Inc., dated 10/04/2005, signed by Javier Trevino. *"Submitted under NOA #15-0423.06"*

F. STATEMENTS

1. Statement letter of code conformance to 2010, 5th Edition (2014) and 6th Edition (2017) FBC issued by Clopay Building Products Company, dated 08/02/2017, signed and sealed by Mark Westerfield, P.E. *"Submitted under NOA #17-0809.20"*
1. Certificate of amendment changing the company name from Clopay Building Products Company, Inc. to Clopay Corporation, issued by the State of Delaware, dated 08/27/2019. *"Submitted under NOA #20-0512.03"*

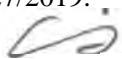
Sifang Zhao P.E.
Product Control Examiner
NOA No 20-0922.53
Expiration Date: July 02, 2025
Approval Date: December 24, 2020

NOTICE OF ACCEPTANCE: EVIDENCE SUBMITTED

3. NEW EVIDENCE SUBMITTED

A. DRAWINGS

1. Drawing No. **104811**, titled “Commercial Ribbed Steel Doors up to 12’-2” W”, sheets 1 through 3 of 3, dated 04/15/2015, with revision 5 dated 09/09/2020, prepared by Clopay Building Products Company, signed and sealed by Mark Westerfield, P.E.

B. TESTS

1. None.

C. CALCULATIONS

1. None.

D. QUALITY ASSURANCE

1. Miami-Dade Department of Regulatory and Economic Resources (RER)

E. MATERIAL CERTIFICATIONS

1. None.

F. STATEMENTS

1. Statement letter of code conformance to the 6th Edition (2017) FBC, 7th Edition (2020) FBC, and Statement letter of no financial interest, issued by Clopay Corporation, dated 09/15/2020, signed and sealed by Mark Westerfield, P.E.



Sifang Zhao P.E.
Product Control Examiner
NOA No 20-0922.53
Expiration Date: July 02, 2025
Approval Date: December 24, 2020

CLOPAY / IDEAL / HOLMES
 524 / C4ST / 224 / 24GA 1-7/8" RIBBED
 524V / C4SV / 224V / 24GA 1-7/8" RIBBED INSULATION
 524S / C4SS / 224X / 24GA 1-7/8" RIBBED INSULATION WITH STEEL BACKER
 520 / COST / --- / 20GA 1-7/8" RIBBED
 520S / COSS / --- / 20GA 1-7/8" RIBBED INSULATION WITH STEEL BACKER

SHEET:
 1 OF 3

REVISIONS					
REV. NO.	ZONE:	DATE:	ECN NO.	APPVD:	DESCRIPTION
02	-	4/15/15	-	MWW	REVISED LAYOUT TO 3 PAGES
03	-	7/17/17	-	SH	UPDATED CODE COMPLIANCE STATEMENT TO ADD 6TH EDITION FBC.
04	-	3/19/20	-	MWW	UPDATED TITLE BLOCK
05	-	9/9/20	-	SH	UPDATED CODE COMPLIANCE STATEMENT TO 7TH EDITION FBC

3" x 20 GA. GALV. STEEL U-BARS ARRANGED WITH 2 U-BARS PER SECTION U-BARS ATTACHED AT EACH STILE LOCATION WITH (2) 1/4" x 3/4" SELF-TAPPING SCREWS

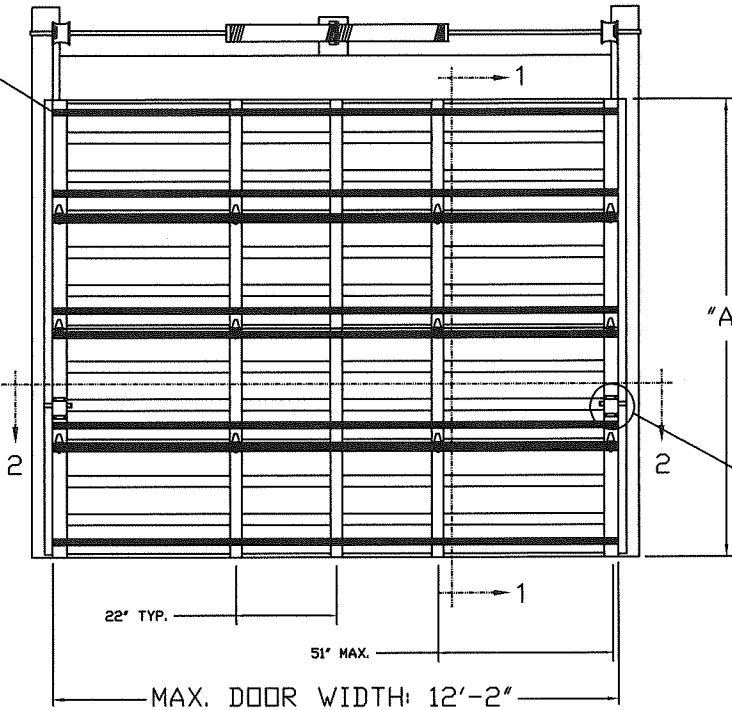

TABLE 1

"A" DOOR HEIGHT	TOTAL U-BARS REQUIRED
4'3" TO 6'0"	6
6'3" TO 8'0"	8
8'3" TO 10'0"	10
10'3" TO 12'0"	12
12'3" TO 14'0"	14
14'3" TO 16'0"	16
16'3" TO 18'0"	18

DOOR HEIGHT 'A'	NUMBER OF SECTIONS
UP TO 8'-0"	4
8'-3" THRU 10'-0"	5
10'-3" THRU 12'-0"	6
12'-3" THRU 14'-0"	7
14'-3" THRU 16'-0"	8
16'-3" THRU 18'-0"	9

PRODUCT REVISED
 as complying with the Florida Building Code
 NOA-No. 20-0922.53

Expiration Date 07/02/2025

By *[Signature]*
 Miami-Dade Product Control

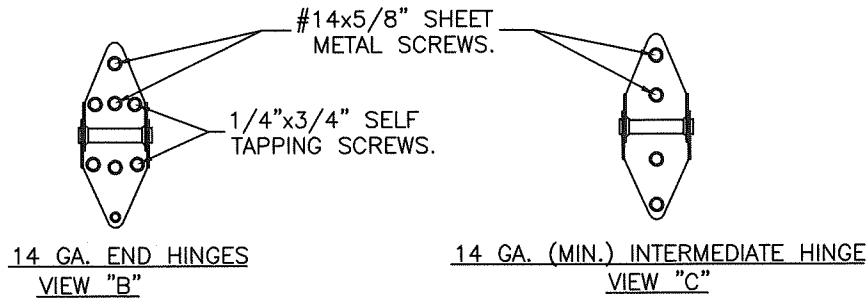

THIS PRODUCT CONFORMS TO THE REQUIREMENTS OF 6TH AND 7TH EDITION OF THE FLORIDA BUILDING CODE

MANUFACTURING PRODUCT CODE
 C-PAN-1E448

PART NO.: N/A

WINDLOAD RATING
 W6 DP36

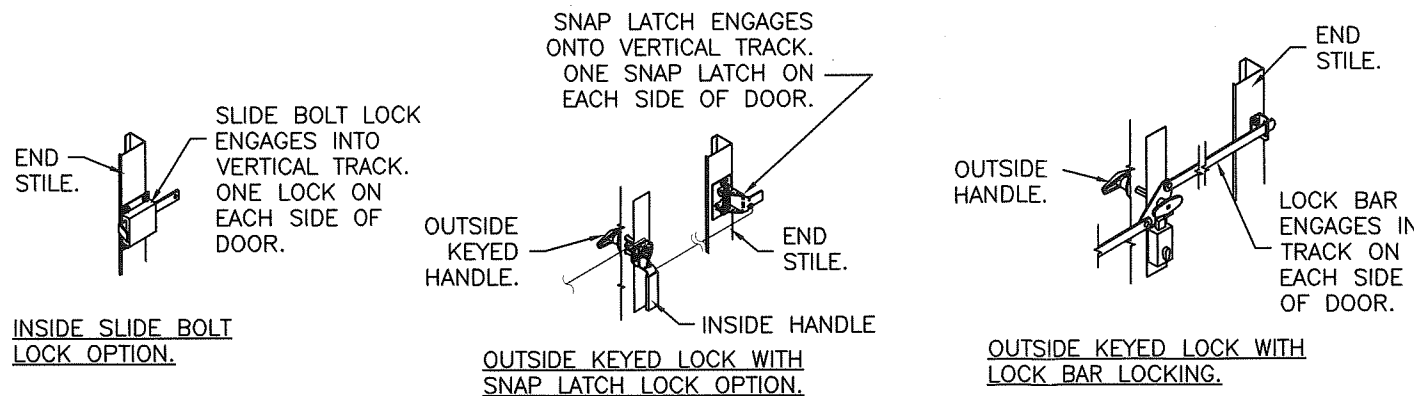

DESIGN LOADS: +36.0 P.S.F. & -42.0 P.S.F.

Unless Stated Otherwise TOLERANCES are
 .0 = ±.031
 .00 = ±.015
 .000 = ±.005
 .0000 = ±.001
 Degrees = ±1/2"
 Unless Stated Otherwise DIMENSIONS ARE IN INCHES.

Clopay CORPORATION
 8585 Duke Boulevard
 Mason, OH 45040 USA
 Tel. No. 513-770-4800
 Fax No. 513-770-4853

DESCRIPTION: COMMERCIAL RIBBED STEEL DOORS UP TO 12'2"W
 DRAWN BY: SH DATE: 12/1/14 SCALE: NTS DWG. SIZE B
 CHECKED BY: MWW DATE: 4/15/15 SHEET 1 OF 3
 DWG. NO.: 104811 VER: M-D

DESIGN ENGINEER:
 MARK WESTERFIELD, P.E.
 FLORIDA P.E. #48495

CLOPAY / IDEAL / HOLMES				
524 / C4ST / 224	/	24GA 1-7/8"	RIBBED	
524V / C4SV / 224V	/	24GA 1-7/8"	RIBBED INSULATION	
524S / C4SS / 224X	/	24GA 1-7/8"	RIBBED INSULATION WITH STEEL BACKER	
520 / COST / ---	/	20GA 1-7/8"	RIBBED	
520S / COSS / ---	/	20GA 1-7/8"	RIBBED INSULATION WITH STEEL BACKER	

SHEET:
2 OF 3

REVISIONS					DESCRIPTION
REV. NO.	ZONE:	DATE:	ECN NO.	APPVD:	
05	-	--	-	--	SEE REVISION HISTORY ON SHEET ONE.

JAMB TO SUPPORTING STRUCTURE ATTACHMENT

NOTES:

1. ALL THE LOAD FROM THE DOOR IS TRANSFERRED TO THE TRACK AND THEN FROM THE TRACK TO THE 2x6 VERTICAL SYP (GRADE #2 OR BETTER) JAMBS. NO LOAD FROM THE DOOR IS TRANSFERRED TO THE HORIZONTAL (TOP) JAMB.
2. EACH VERTICAL JAMB SEES A MAXIMUM DESIGN LOAD OF +185 LB & -220 LB. PER LINEAR FOOT OF JAMB.
3. ALL JAMB FASTENERS MAY BE (BUT ARE NOT REQUIRED TO BE) COUNTERSUNK TO PROVIDE A FLUSH MOUNTING SURFACE.
4. A 1/3 STRESS INCREASE FOR WIND LOAD WAS NOT USED IN THE CALCULATION OF ALLOWABLE LOADS FOR ANCHORS AND FASTENERS FOR STEEL, CONCRETE AND MASONRY.

NOTE: 2x6 WOOD JAMBS ARE NOT REQUIRED WITH CONTINUOUS ANGLE MOUNT TRACK. HOWEVER, IF DESIRED ON STEEL JAMBS OR CONCRETE OR BLOCK WALLS, APPROVED FASTENERS AS DETAILED BELOW SHOULD BE INCREASED IN LENGTH BY 1-1/2" AND INSTALLED DIRECTLY THROUGH THE ANGLE AND 2x6 WOOD JAMBS INTO THE STEEL JAMBS OR CONCRETE OR BLOCK WALLS. ANCHORS CAN BE (BUT ARE NOT REQUIRED TO BE) COUNTERSUNK TO PROVIDE A FLUSH MOUNTING SURFACE. CONTINUOUS ANGLE TRACK CAN BE ANCHORED DIRECTLY TO GROUT REINFORCED BLOCK WALL OR 3,000 PSI MIN. CONCRETE COLUMN OR STEEL JAMBS.

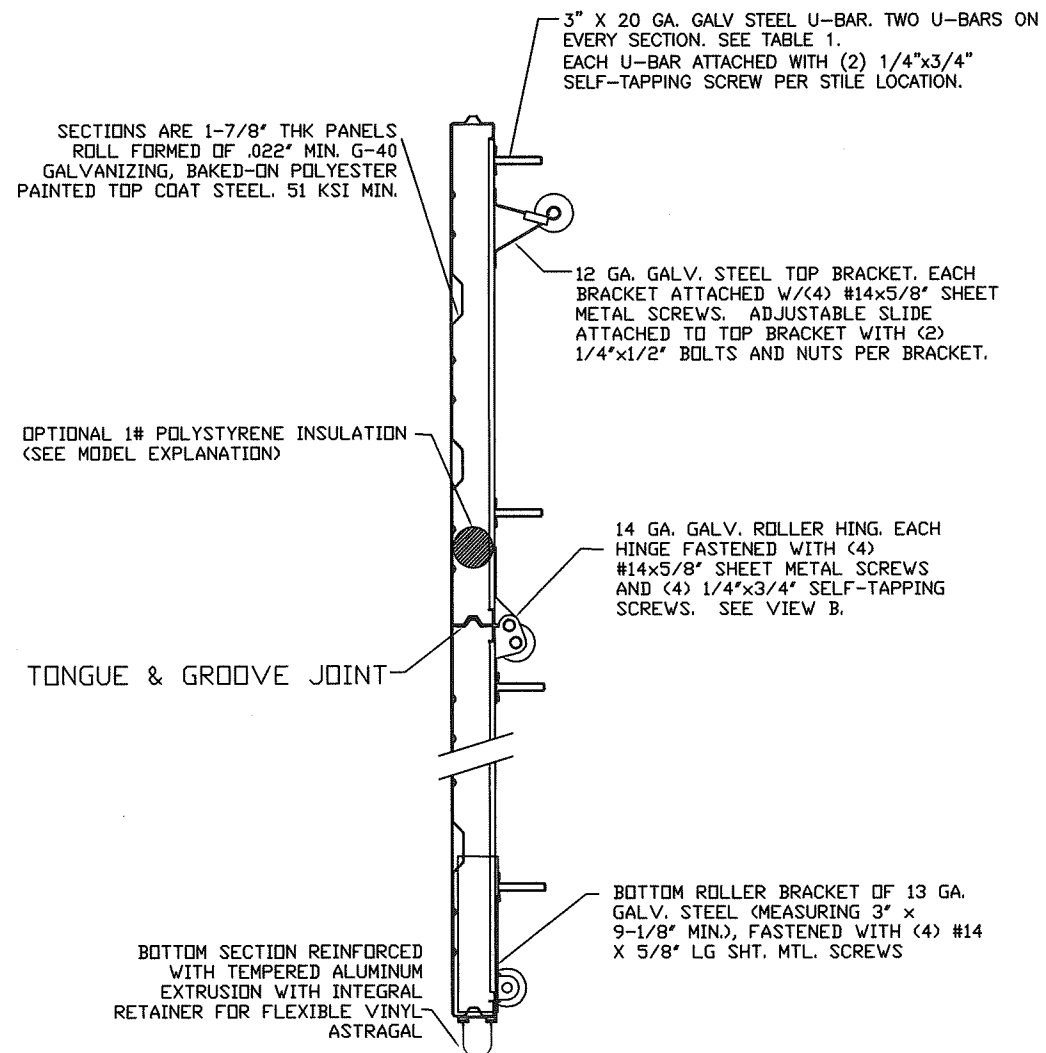
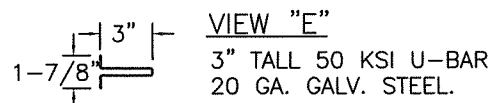
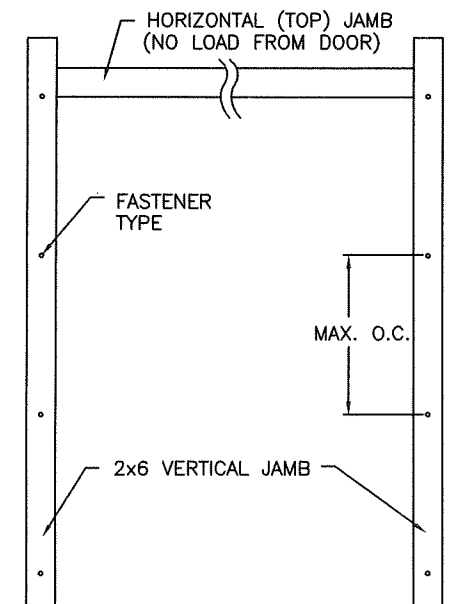

SECTION A-A (SIDE VIEW)

PRODUCT REVISED
as complying with the Florida Building Code

NOA-No. 20-0922.53

Expiration Date 07/02/2025

By *[Signature]*
Miami-Dade Product Control

FASTENER ATTACHMENT TO SUPPORTING STRUCTURE SCHEDULES

BUILDING TYPE	FASTENER TYPE	MAXIMUM ON-CENTER DISTANCE BETWEEN FASTENERS*	STEEL WASHERS REQUIRED?
HOLLOW BLOCK WALL	1/4" x 1-1/4" MIN. EMBED ULTRACON CONCRETE ANCHOR	7-3/4"	1" O.D.
GROUT FILLED BLOCK WALL	1/4" x 1-3/4" MIN. EMBED ULTRACON CONCRETE ANCHOR	12-3/4"	1" O.D.
2000 PSI MIN. CONCRETE	1/4" x 1" MIN. EMBED ULTRACON CONCRETE ANCHOR	11"	1" O.D.
2000 PSI MIN. CONCRETE	1/4" x 1" MIN. EMBED TAPCON CONCRETE ANCHOR	9-1/2"	1" O.D.
2000 PSI MIN. CONCRETE	3/8" x 1-3/4" MIN. EMBED WEJ-IT ANKR TITE SLEEVE ANCHOR	23-1/4"	INCLUDED
4000 PSI MIN. CONCRETE	3/8" x 1-3/4" MIN. EMBED WEJ-IT ANKR TITE SLEEVE ANCHOR	24"	INCLUDED
WOOD FRAME (SYP 0.55 SG)	1/2" x 3" LAG SCREW (ASTM A307, GRADE A) 1-5/8" EMBED INTO STRUCTURE	24"	1" O.D.
14GA STEEL (0.060" MIN.)	1/4"-14 x 1" ITW BUILDEX TEKS SELF-DRILLING FASTENER	10-1/2"	1" O.D.
12GA STEEL (0.105" MIN.)	1/4"-14 x 1" ITW BUILDEX TEKS SELF-DRILLING FASTENER	18-1/2"	1" O.D.
1/8" STEEL	1/4"-14 x 1" ITW BUILDEX TEKS SELF-DRILLING FASTENER	22"	1" O.D.

* FIRST (BOTTOM) ANCHOR STARTING AT NO MORE THAN HALF OF THE MAXIMUM ON-CENTER DISTANCE. HIGHEST ANCHOR INSTALLED AT LEAST AS HIGH AS THE DOOR OPENING.
CLOPAY DOES NOT SUPPLY JAMB ATTACHMENT FASTENERS.
MINIMUM DISTANCE BETWEEN CENTER OF ANCHOR AND EDGE OF CONCRETE BLOCK: 2-1/2", EXCLUDING STUCCO THICKNESS.

DESIGN LOADS: +36.0 P.S.F. & -42.0 P.S.F.

Unless Stated Otherwise
TOLERANCES are
.0 = ±.031
.00 = ±.015
.000 = ±.005
.0000 = ±.001
Degrees = ±1/2"
Unless Stated Otherwise
DIMENSIONS ARE IN INCHES.



8585 Duke Boulevard
Mason, OH 45040 USA
Tel. No. 513-770-4800
Fax No. 513-770-4853

MANUFACTURING PRODUCT CODE
C-PAN-1E448

PART NO.: N/A

WINDLOAD RATING
W6 DP36

DESCRIPTION: COMMERCIAL RIBBED STEEL DOORS UP TO 12'2"W

DRAWN BY: SH	DATE: 12/1/14	SCALE: NTS	DWG. SIZE B
CHECKED BY: MWW	DATE: 4/15/15	SHEET 2 OF 3	

DWG. NO.: 104811 VER: M-D



DESIGN ENGINEER:
MARK WESTERFIELD, P.E.
FLORIDA P.E. #48495

CLOPAY / IDEAL / HOLMES			
524 / C4ST / 224	/	24GA 1-7/8" RIBBED	
524V / C4SV / 224V	/	24GA 1-7/8" RIBBED INSULATION	
524S / C4SS / 224X	/	24GA 1-7/8" RIBBED INSULATION WITH STEEL BACKER	
520 / C0ST / ---	/	20GA 1-7/8" RIBBED	
520S / C0SS / ---	/	20GA 1-7/8" RIBBED INSULATION WITH STEEL BACKER	

SHEET:
3 OF 3

REVISIONS					
REV. NO.	ZONE	DATE	ECN NO.	APPVD	DESCRIPTION
05	-	--	-	--	SEE REVISION HISTORY ON SHEET ONE.

2" TRACK CONFIGURATION
DOORS UP TO 800 LBS.

NOTE DOUBLE TRACK HEADROOM, HI-LIFT TRACK, FOLLOW-THE-ROOF TRACK, AND VERTICAL LIFT TRACK ARE AVAILABLE OPTIONS. TRACK CONFIGURATION ABOVE THE DOOR OPENING DOES NOT AFFECT THE WIND LOAD RATING.

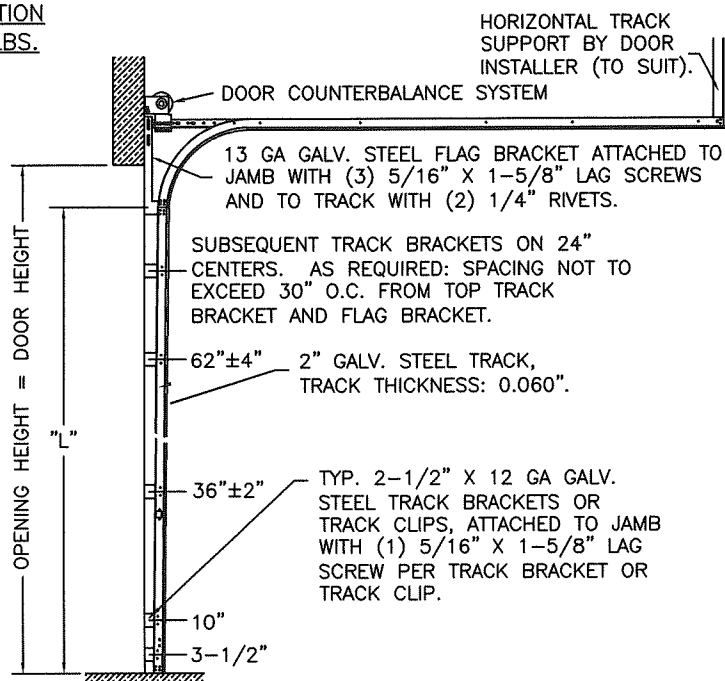

DOOR HEIGHT	"L"
6'-6"	70"
7'-0"	76"
7'-6"	82"
8'-0"	88"
8'-6"	94"
9'-0"	100"
9'-6"	106"
10'-0"	112"
10'-6"	118"
11'-0"	124"
11'-6"	130"
12'-0"	136"
12'-6"	142"
13'-0"	148"
13'-6"	154"
14'-0"	160"
14'-6"	166"
15'-0"	172"
15'-6"	178"
16'-0"	184"
16'-6"	190"
17'-0"	196"
17'-6"	202"
18'-0"	208"

PRODUCT REVISED
as complying with the Florida Building Code
NOA-No. 20-0922.53
Expiration Date 07/02/2025
By *[Signature]*
Miami-Dade Product Control

JAMB CONFIGURATION
DOORS UP TO 800 LBS.

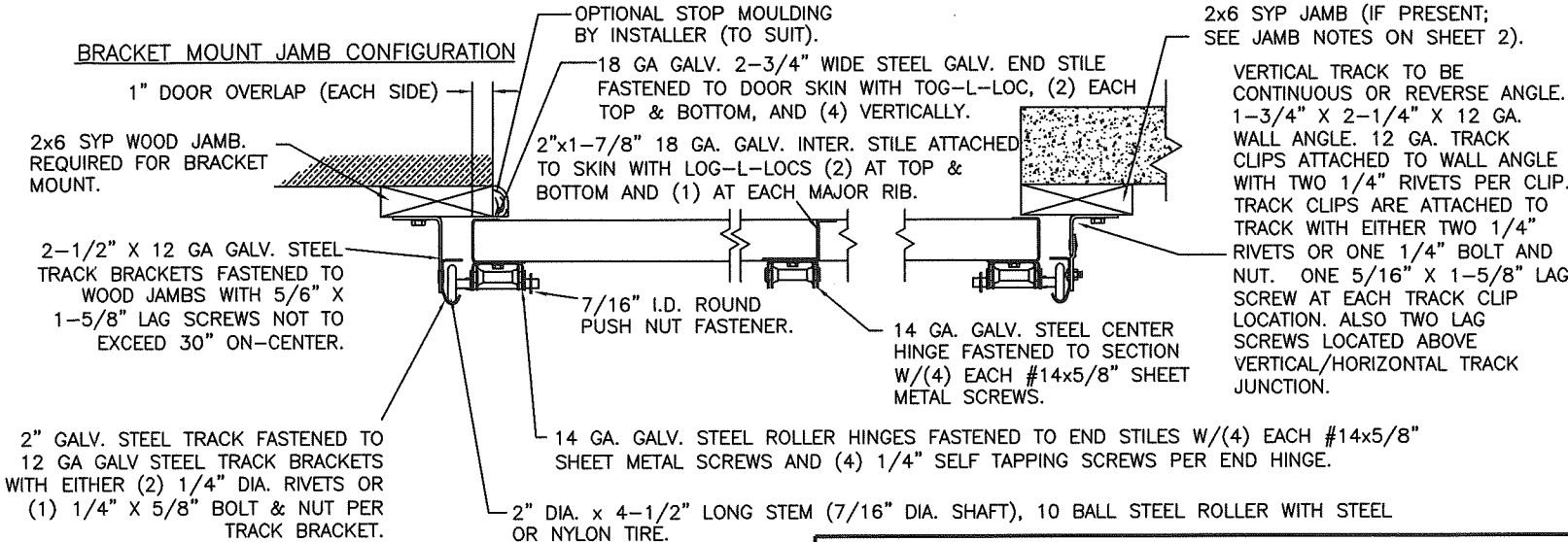

PREPARATION OF JAMBS BY OTHERS.

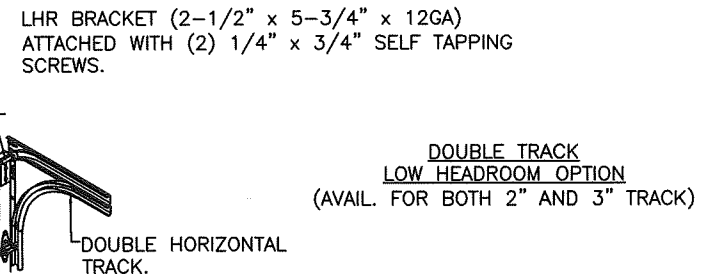

3" TRACK CONFIGURATION
DOORS 800 LBS AND OVER.

NOTE DOUBLE TRACK HEADROOM, HI-LIFT TRACK, FOLLOW-THE-ROOF TRACK, AND VERTICAL LIFT TRACK ARE AVAILABLE OPTIONS. TRACK CONFIGURATION ABOVE THE DOOR OPENING DOES NOT AFFECT THE WIND LOAD RATING.

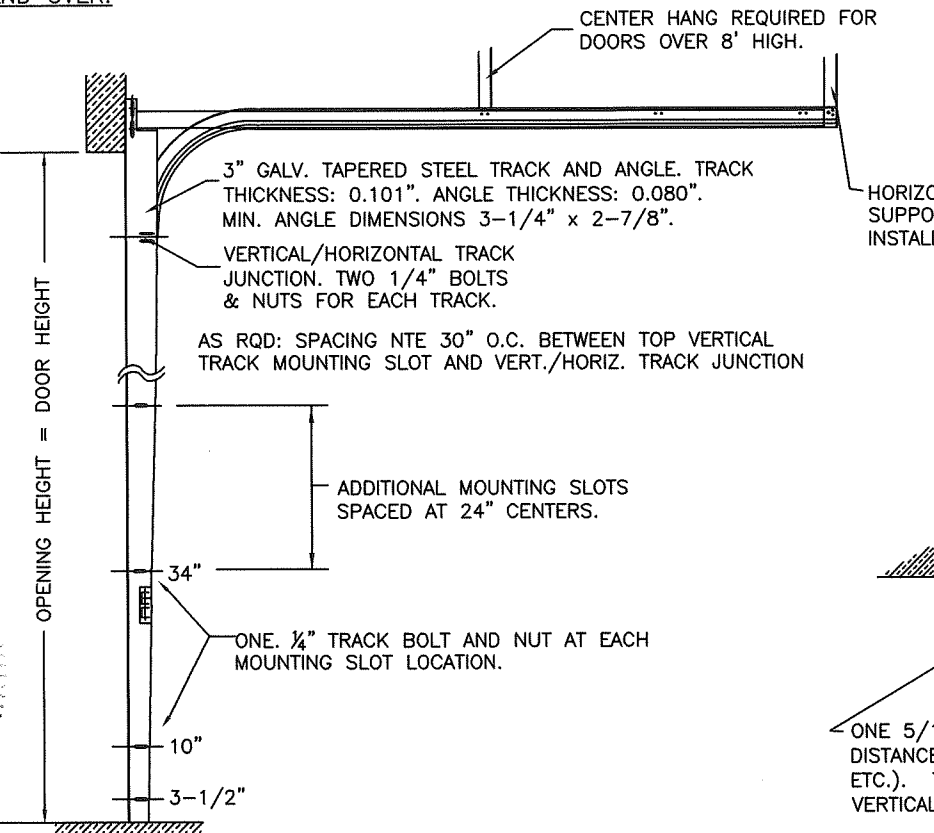

JAMB CONFIGURATION
DOORS 800 LBS AND OVER.

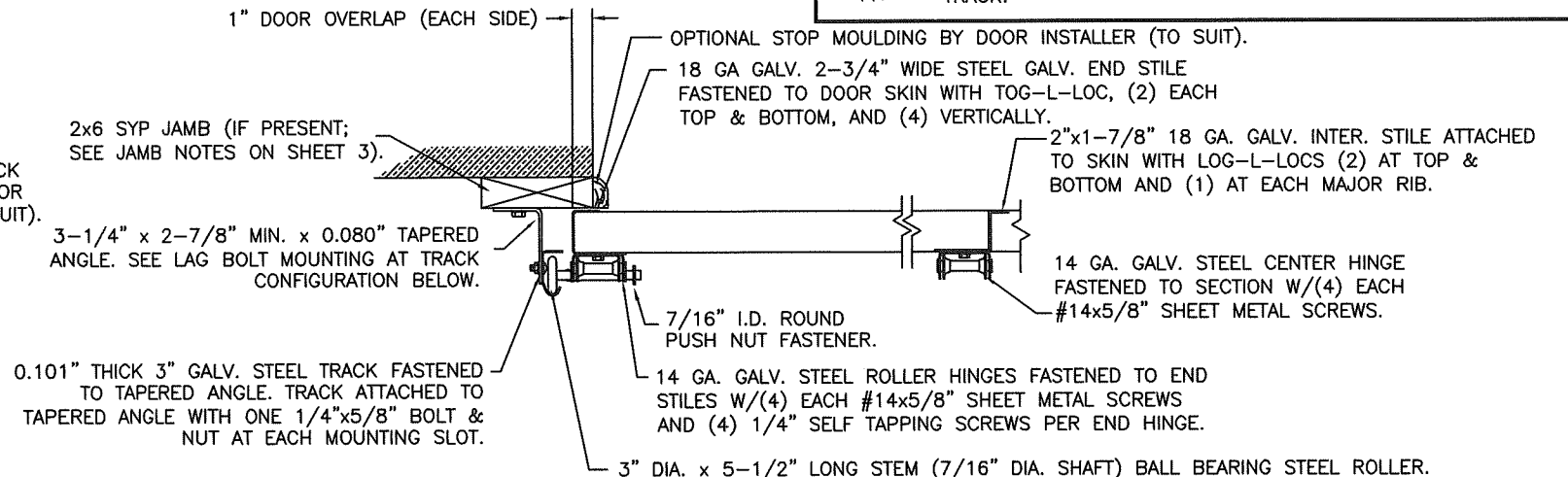

PREPARATION OF JAMBS BY OTHERS.

DOOR HEIGHT	VERTICAL TRACK LENGTH
7'-0"	72"
8'-0"	84"
9'-0"	96"
10'-0"	108"
12'-0"	132"
14'-0"	156"
16'-0"	180"
17'-0"	204"
18'-0"	228"

DESIGN ENGINEER:
MARK WESTERFIELD, P.E.
FLORIDA P.E. #48495

DESIGN LOADS: +36.0 P.S.F. & -42.0 P.S.F.

Unless Stated Otherwise
TOLERANCES are
.0 = ±.031
.00 = ±.015
.000 = ±.005
.0000 = ±.001
Degrees = ±1/2°
Unless Stated Otherwise
DIMENSIONS ARE IN INCHES.

Clopay
CORPORATION
8585 Duke Boulevard
Mason, OH 45040 USA
Tel. No. 513-770-4800
Fax No. 513-770-4853

MANUFACTURING PRODUCT CODE
C-PAN-1E448

PART NO.: N/A

WINDLOAD RATING
W6 DP36

DESCRIPTION: COMMERCIAL RIBBED STEEL DOORS UP TO 12'2"W			
DRAWN BY: SH	DATE: 12/1/14	SCALE: NTS	DWG. SIZE B
CHECKED BY: MWW	DATE: 4/15/15	SHEET 3 OF 3	
DWG. NO.: 104811	VER: M-D		