



**MIAMI-DADE COUNTY
PRODUCT CONTROL SECTION**

11805 SW 26 Street, Room 208
Miami, Florida 33175-2474
T (786) 315-2590 F (786) 315-2599

**DEPARTMENT OF REGULATORY AND ECONOMIC RESOURCES (RER)
BOARD AND CODE ADMINISTRATION DIVISION**

www.miamidade.gov/economy

NOTICE OF ACCEPTANCE (NOA)

**Cornell Iron Works, Inc.
24 Elmwood Avenue
Mountaintop, PA 18707**

SCOPE: This NOA is being issued under the applicable rules and regulations governing the use of construction materials. The documentation submitted has been reviewed and accepted by Miami-Dade County RER-Product Control Section to be used in Miami-Dade County and other areas where allowed by the Authority Having Jurisdiction (AHJ).

This NOA shall not be valid after the expiration date stated below. The Miami-Dade County Product Control Section (In Miami-Dade County) and/or the AHJ (in areas other than Miami-Dade County) reserve the right to have this product or material tested for quality assurance purposes. If this product or material fails to perform in the accepted manner, the manufacturer will incur the expense of such testing and the AHJ may immediately revoke, modify, or suspend the use of such product or material within their jurisdiction. RER reserves the right to revoke this acceptance if it is determined by Miami-Dade County Product Control Section that this product or material fails to meet the requirements of the applicable building code.

This product is approved as described herein and has been designed to comply with the Florida Building Code, including the High Velocity Hurricane Zone.

DESCRIPTION: StormDefender Non-Insulated Steel Rolling Door up to 14ft-0in Wide (200 PSF, 80 FPS Impact)

APPROVAL DOCUMENT: Drawing No. **ES-16-79-CIW**, titled “StormDefender Non-Insulated Rolling Steel Door 200 PSF 80 FPS”, sheets 1 through 7 of 7, with revision **A** dated 02/06/2020, prepared by Cornell Iron Works, Inc, signed and sealed by Shawn Patrick Kelley, P.E. on 03/18/2020, bearing the Miami-Dade County Product Control revision stamp with the Notice of Acceptance number and expiration date by the Miami-Dade County Product Control Section.

MISSILE IMPACT RATING: Large and Small Missile Impact Resistant

LABELING: A permanent label with the manufacturer’s name or logo, one of the 2 manufacturing addresses on drawings, model number, the positive and negative design pressure rating, indicate impact rated if applicable, installation instruction drawing reference number, approval number (NOA), the applicable test standards, and the statement reading ‘Miami-Dade County Product Control Approved’ is to be located on the door’s side track, bottom angle, or inner surface of a panel.

RENEWAL of this NOA shall be considered after a renewal application has been filed and there has been no change in the applicable building code negatively affecting the performance of this product.

TERMINATION of this NOA will occur after the expiration date or if there has been a revision or change in the materials, use, and/or manufacture of the product or process. Misuse of this NOA as an endorsement of any product, for sales, advertising or any other purposes shall automatically terminate this NOA. Failure to comply with any section of this NOA shall be cause for termination and removal of NOA.

ADVERTISEMENT: The NOA number preceded by the words Miami-Dade County, Florida, and followed by the expiration date may be displayed in advertising literature. If any portion of the NOA is displayed, then it shall be done in its entirety.

INSPECTION: A copy of this entire NOA shall be provided to the user by the manufacturer or its distributors and shall be available for inspection at the job site at the request of the Building Official.

This NOA **revises NOA # 20-0416.24** and consists of this page 1 and evidence pages E-1 and E-2, as well as approval document mentioned above.

The submitted documentation was reviewed by **Carlos M. Utrera, P.E.**



**NOA-No. 20-0925.14
Expiration Date: January 09, 2025
Approval Date: December 10, 2020
Page 1**

NOTICE OF ACCEPTANCE: EVIDENCE SUBMITTED

1. EVIDENCE SUBMITTED UNDER NOA # 19-0326.02

A. DRAWINGS

1. Drawing No. **ES-16-79-CIW**, titled “StormDefender Non-Insulated Rolling Steel Door 200 PSF 80 FPS”, sheets 1 through 7 of 7, prepared by Cornell Iron Works, Inc, signed and sealed by Shawn Patrick Kelley, P.E. on 11/16/2018.

B. TESTS

1. Test reports on 1) Uniform Static Air Pressure Test, Loading per FBC, TAS 202-94
2) Large Missile Impact Test per FBC, TAS 201-94 (Level ‘E’)
3) Cyclic Wind Pressure Loading per FBC, TAS 203-94
4) Forced Entry Test, per FBC 2411.3.2.1, and TAS 202-94
5) Tensile Test per ASTM E8-15a

along with marked-up drawings and installation diagram of Roll-up Garage Doors, prepared by Intertek, Test Report No. **H7081.02-109-18**, dated 05/14/2018, signed and sealed by Joseph A. Reed, P.E.

2. Test report on Tensile Properties per ASTM E8-15a, Standard Test Method for Tensile Testing of Metallic Materials, prepared by Intertek, Test Report No. **H7081.03-106-18**, dated 05/14/2018.
3. Test report on Salt Spray Performance Test per ASTM B117-16, Evaluation of Painted Specimens Subjected to Corrosive Environments per ASTM D1654, prepared by Intertek, Test Report No. **H7081.04-106-18 R0**, dated 05/11/2017, signed and sealed by Gary Hartman, P.E.

C. CALCULATIONS

1. Calculations prepared by signed and sealed by Shawn Patrick Kelley, P.E. on 11/16/2018

D. QUALITY ASSURANCE

1. Miami-Dade Department of Regulatory and Economic Resources (RER).

E. MATERIAL CERTIFICATIONS

1. None.

F. STATEMENTS

1. Private label agreement dated 03/01/2019.
2. Statement letter of code conformance to **FBC 6th Edition (2017)** and of independence and no financial interest, dated January 10, 2019, issued and prepared by Moment Engineering + Design, LLC, signed and sealed by Shawn Patrick Kelley, P.E.



Carlos M. Utrera, P.E.
Product Control Examiner
NOA-No. 20-0925.14
Expiration Date: January 09, 2025
Approval Date: December 10, 2020

NOTICE OF ACCEPTANCE: EVIDENCE SUBMITTED

2. EVIDENCE SUBMITTED UNDER NOA # 20-0416.24

A. DRAWINGS

1. Drawing No. **ES-16-79-CIW**, titled "StormDefender Non-Insulated Rolling Steel Door 200 PSF 80 FPS", sheets 1 through 7 of 7, with revision **A** dated 02/06/2020, prepared by Cornell Iron Works, Inc, signed and sealed by Shawn Patrick Kelley, P.E. on 03/18/2020.

B. TESTS

1. None.

C. CALCULATIONS

1. None.

D. QUALITY ASSURANCE

1. Miami-Dade Department of Regulatory and Economic Resources (RER).

E. MATERIAL CERTIFICATIONS

1. None.

F. STATEMENTS

1. Statement letter of code conformance to **FBC 6th Edition (2017)** and of no financial interest, dated March 21, 2020, issued and prepared by Moment Engineering+ Design, LLC, signed and sealed by Shawn Patrick Kelley, P.E.
2. Private label agreement dated 02/27/2020.

3. EVIDENCE SUBMITTED

A. DRAWINGS

1. None.

B. TESTS

1. None.

C. CALCULATIONS

1. None.

D. QUALITY ASSURANCE

1. Miami-Dade Department of Regulatory and Economic Resources (RER).

E. MATERIAL CERTIFICATIONS

1. None.

F. STATEMENTS

1. Statement letter of code conformance to **FBC 7th Edition (2020)** and of no financial interest, dated August 12, 2020, issued and prepared by Moment Engineering + Design, LLC, signed and sealed by Shawn Patrick Kelley, P.E.



Carlos M. Utrera, P.E.
Product Control Examiner
NOA-No. 20-0925.14
Expiration Date: January 09, 2025
Approval Date: December 10, 2020

L'TR	REVISION	DATE	BY	E.C.O.
*	ORIGINAL ISSUE	10/02/2018	TJE	1853
A	REVISED TITLE BLOCK; HOOD SUPPORT UPDATE	02/06/2020	MAN	2026

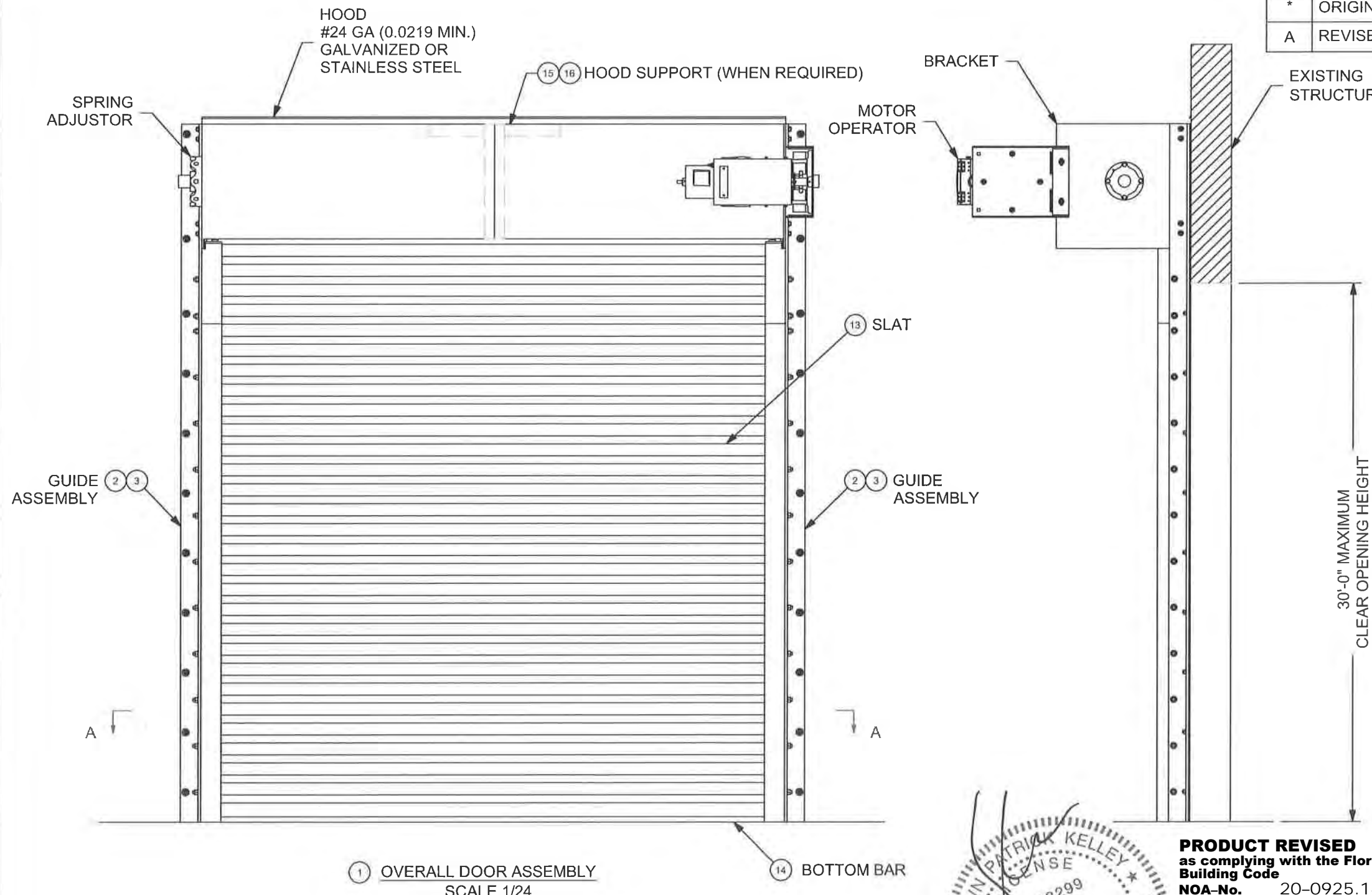

- NOTES:**
1. THESE PRODUCT EVALUATION DOCUMENTS REPRESENT A ROLL-UP DOOR ASSEMBLY DESIGNED AND TESTED IN ACCORDANCE WITH THE STANDARD BUILDING CODE, THE INTERNATIONAL BUILDING CODE, AND THE FLORIDA BUILDING CODE.
 2. POSITIVE AND NEGATIVE DESIGN PRESSURE CALCULATIONS SHALL BE PERFORMED FOR SPECIFIC JOBS IN ACCORDANCE WITH ASCE 7 MINIMUM DESIGN LOADS FOR BUILDINGS AND OTHER STRUCTURES. WIND LOADS DETERMINED FOR OPENINGS SHALL BE LESS THAN OR EQUAL TO DOOR DESIGN PRESSURES NOTED BELOW.
 POSITIVE DESIGN LOAD = 200 PSF
 NEGATIVE DESIGN LOAD = 200 PSF
 3. THE DETAILS AND SPECIFICATIONS SHOWN HEREIN REPRESENT THE PRODUCTS TESTED FOR UNIFORM STATIC AIR PRESSURE IN CONFORMANCE WITH FLORIDA BUILDING CODE TEST PROTOCOLS TAS 201, 202, AND 203.
 POSITIVE DESIGN LOAD = 200 PSF
 NEGATIVE DESIGN LOAD = 200 PSF
 4. TESTING PERFORMED BY INTERTEK. (YORK, PENNSYLVANIA) TEST REPORT No. H7081.02-109-18.
 5. THESE PRODUCT EVALUATION DOCUMENTS ARE SUITABLE TO BE APPLIED BY THE CONTRACTOR PROVIDED THE CONTRACTOR DOES NOT DEVIATE FROM THE CONDITIONS DETAILED HEREIN AND THE CONTRACTOR VERIFIES THE EXISTING STRUCTURE IS CAPABLE OF SUPPORTING THE SUPERIMPOSED LOADS V_x & V_y ON THE JAMBS OF THE DOOR.
 6. ALL WELDING SHALL BE PERFORMED BY QUALIFIED WELDERS IN ACCORDANCE WITH AWS SPECIFICATIONS, LATEST EDITION. ALL WELDING ELECTRODES SHALL CONFORM TO AWS A5.1, GRADE E-70. MINIMUM WELDING PROCESS SHALL BE ARC WELDING AWS E7014 OR MIG WELDING AWS ER70S-6.
 7. ANCHOR NOTES:
 A. EMBEDMENT DEPTH DOES NOT INCLUDE STUCCO FINISH.
 B. ANCHORS SHALL BE INSTALLED IN ACCORDANCE WITH MANUFACTURERS SPECIFICATIONS.
 8. DOOR MAY BE INSTALLED ON THE INSIDE OR OUTSIDE OF AN EXTERIOR WALL.
 9. A 33% INCREASE IN ALLOWABLE STRESS HAS NOT BEEN USED IN THE DESIGN OF THIS PRODUCT.
 10. NO LOCKING REQUIRED FOR WINDLOAD RESISTANCE.
 11. WINDLOCKS ARE INTEGRAL TO THE SLAT.
 12. GUIDE ASSEMBLY, BOTTOM BAR & CURTAIN ARE TO BE PROTECTED FROM CORROSION WITH POLYESTER POWDER COATING WHEN NOT MINIMUM G90 GALVANIZED STEEL OR STAINLESS STEEL.



PRODUCT REVISED
 as complying with the Florida Building Code
 NOA-No. 20-0925.14
 Expiration Date 01/09/2025
 By *[Signature]*
 Miami-Dade Product Control

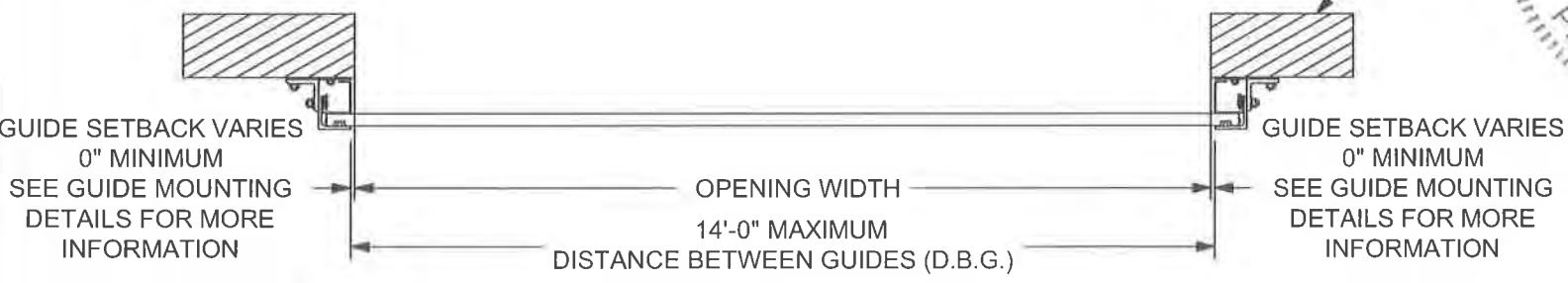

	24 ELMWOOD AVE 1901 S. LITCHFIELD RD MOUNTAINTOP, PA GOODYEAR, AZ	Unless otherwise specified, dimensions are in inches & tolerances are: 0.000 = +/- 0.031 FRACTIONAL = +/- 1/32 ANGLES = +/- 1/2 DEG
	P: 800.233.8366 F: 800.526.0841 E: ADS@CORNELLIRON.COM	
TITLE: MIAMI DADE COUNTY APPROVED STORMDEFENDER NON-INSULATED ROLLING STEEL DOOR 200 PSF 80 FPS		DRAWN BY: TJE DWG NO: ES-16-79-CIW
		SIZE: B SCALE: AS NOTED SHEET: 1/7

L'TR	REVISION	DATE	BY	E.C.O.
*	ORIGINAL ISSUE	10/02/2018	TJE	1853
A	REVISED TITLE BLOCK; HOOD SUPPORT UPDATE	02/06/2020	MAN	2026

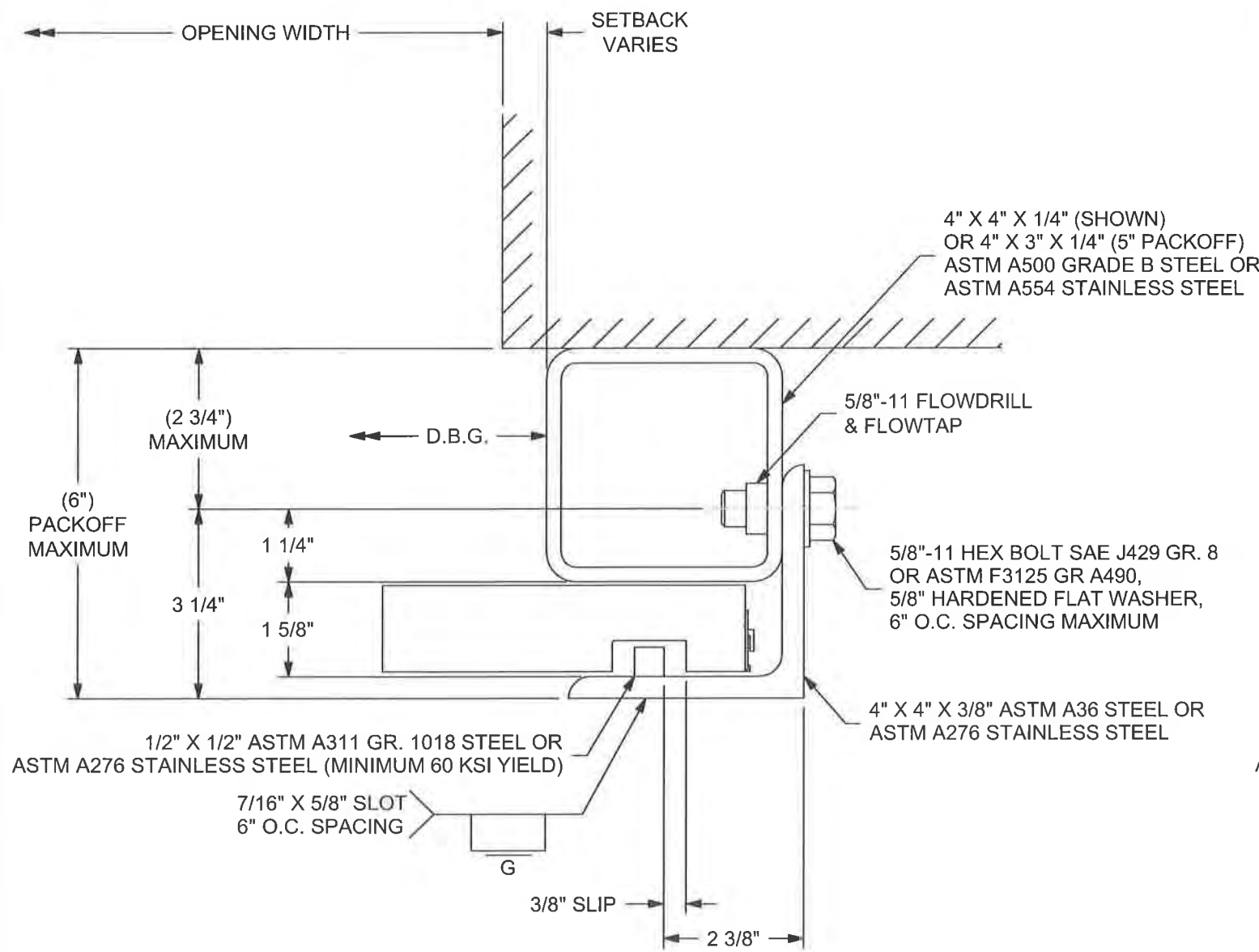

② GUIDE ASSEMBLY - BOX GUIDE
SCALE 3/8

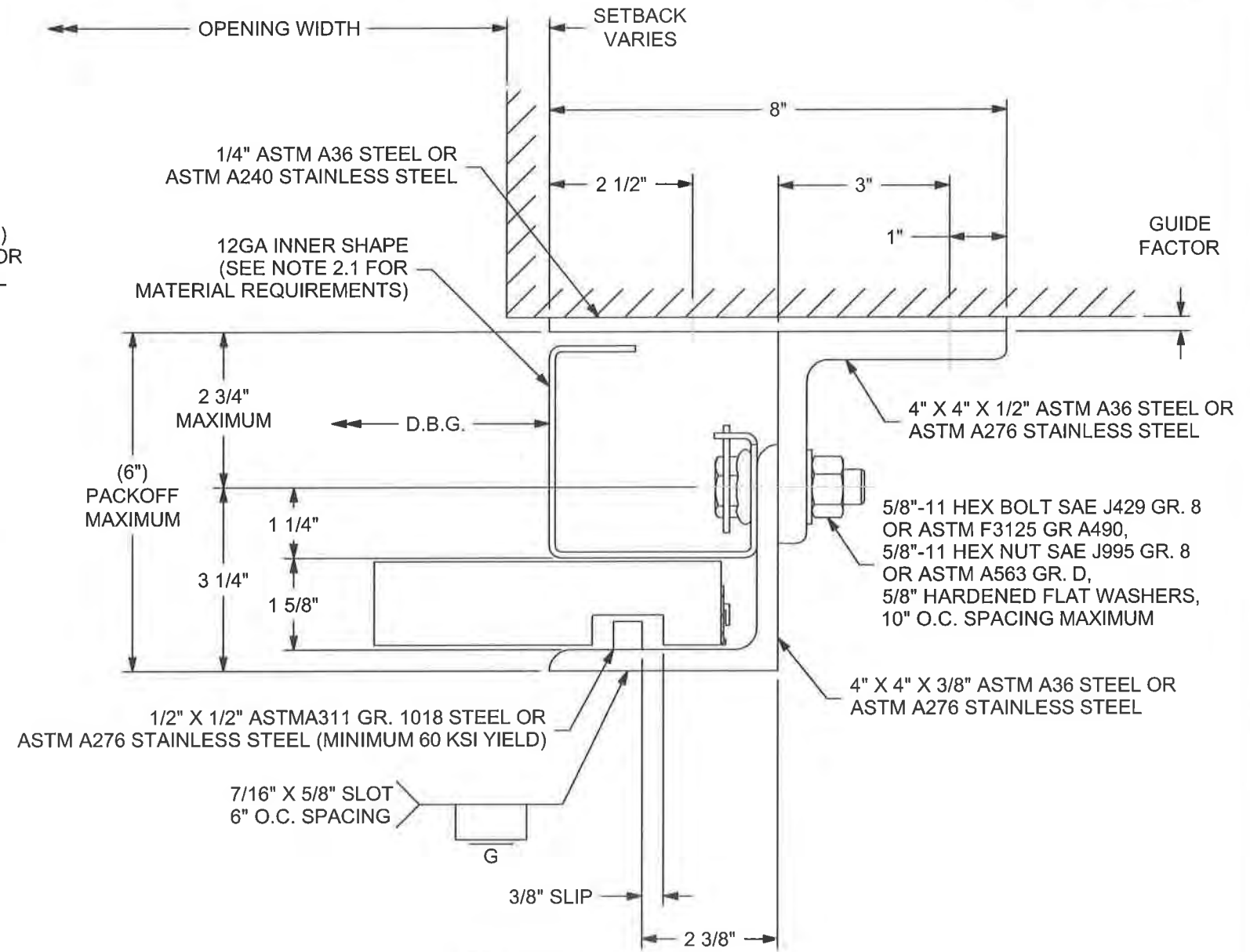

③ GUIDE ASSEMBLY - Z GUIDE
SCALE 3/8

PRODUCT REVISED
as complying with the Florida
Building Code
NOA-No. 20-0925.14
Expiration Date 01/09/2025
By *[Signature]*
Miami-Dade Product Control

NOTES:
2.1 SHEET MATERIAL: ASTM A1011 CS TYPE B (MINIMUM 40 KSI YIELD), SS GRADE 40, HSLAS GRADE 40, HSLAS-F GRADE 40 OR ASTM A666 TYPE 304, 316, 430, OR 201 STAINLESS STEEL (MINIMUM 40 KSI YIELD)



24 ELMWOOD AVE 1901 S. LITCHFIELD RD
MOUNTAINTOP, PA GOODYEAR, AZ
P: 800.233.8366
F: 800.526.0841
E: ADS@CORNELLIRON.COM

Unless otherwise specified, dimensions are in inches & tolerances are:
0.000 = +/- 0.031
FRACTIONAL = +/- 1/32
ANGLES = +/- 1/2 DEG

TITLE: MIAMI DADE COUNTY APPROVED
STORMDEFENDER NON-INSULATED
ROLLING STEEL DOOR 200 PSF 80 FPS

DRAWN BY: TJE
SIZE: B
SCALE: AS NOTED
SHEET: 2/7
DWG NO: ES-16-79-CIW

L'TR	REVISION	DATE	BY	E.C.O.
*	ORIGINAL ISSUE	10/02/2018	TJE	1853
A	REVISED TITLE BLOCK; HOOD SUPPORT UPDATE	02/06/2020	MAN	2026

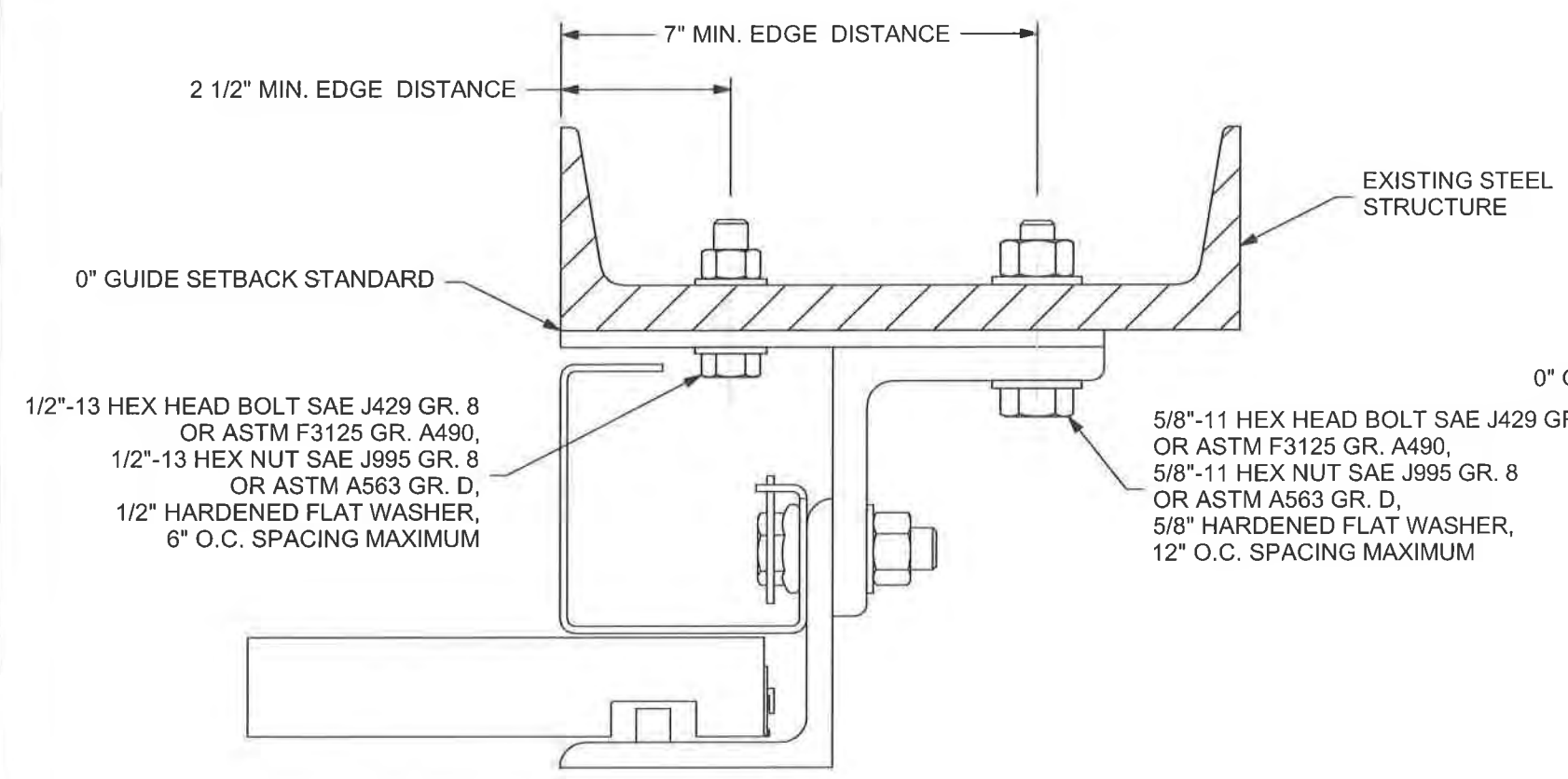

④ GUIDE ASSEMBLY - Z GUIDE BOLTED TO STEEL STRUCTURE
SCALE 3/8

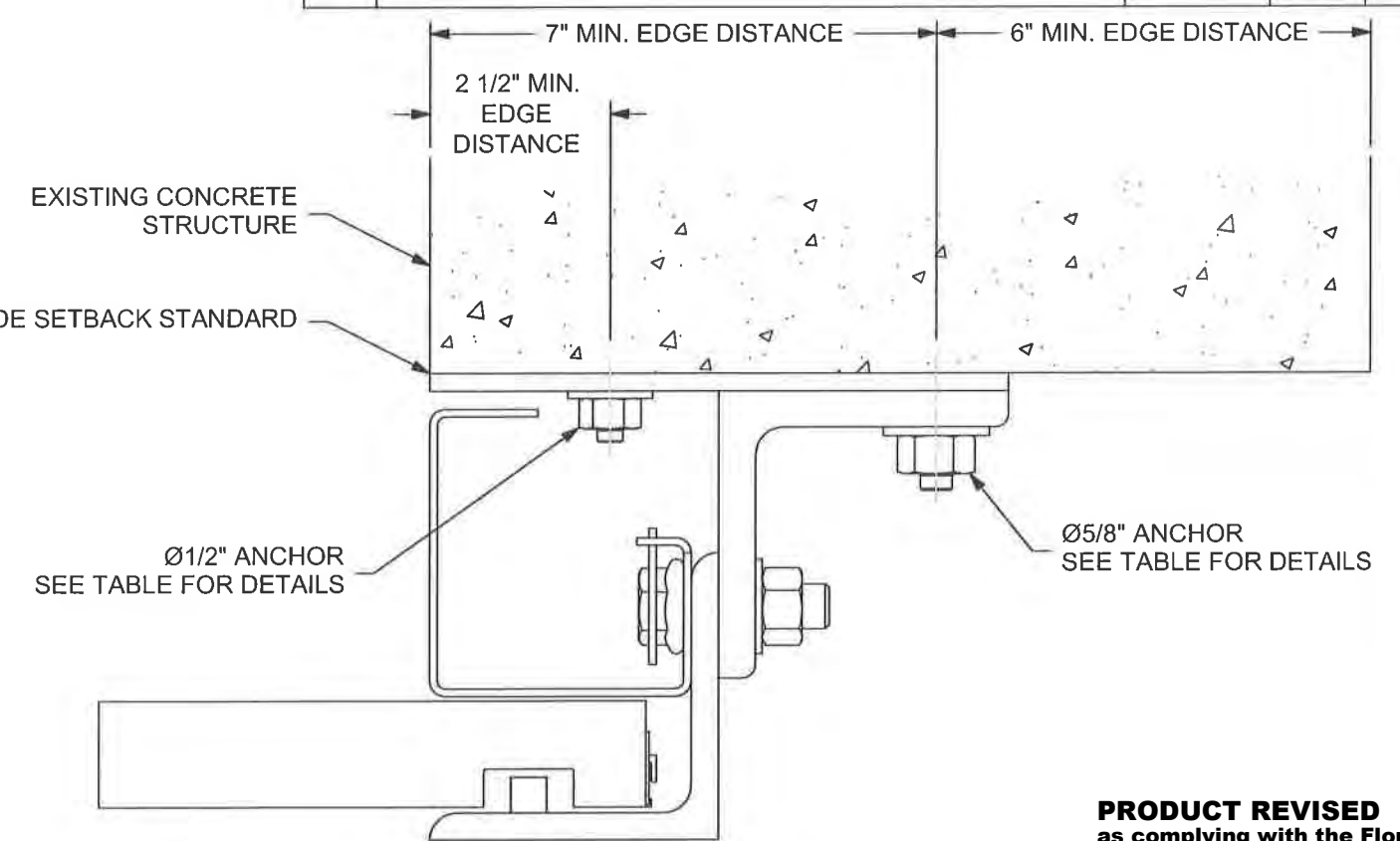

⑤ GUIDE ASSEMBLY - Z GUIDE TO CONCRETE STRUCTURE
MINIMUM 4,000 PSI CONCRETE & 8" THICK
SCALE 3/8

PRODUCT REVISED
as complying with the Florida Building Code
NOA-No. 20-0925.14
Expiration Date 01/09/2025
By *[Signature]*
Miami-Dade Product Control

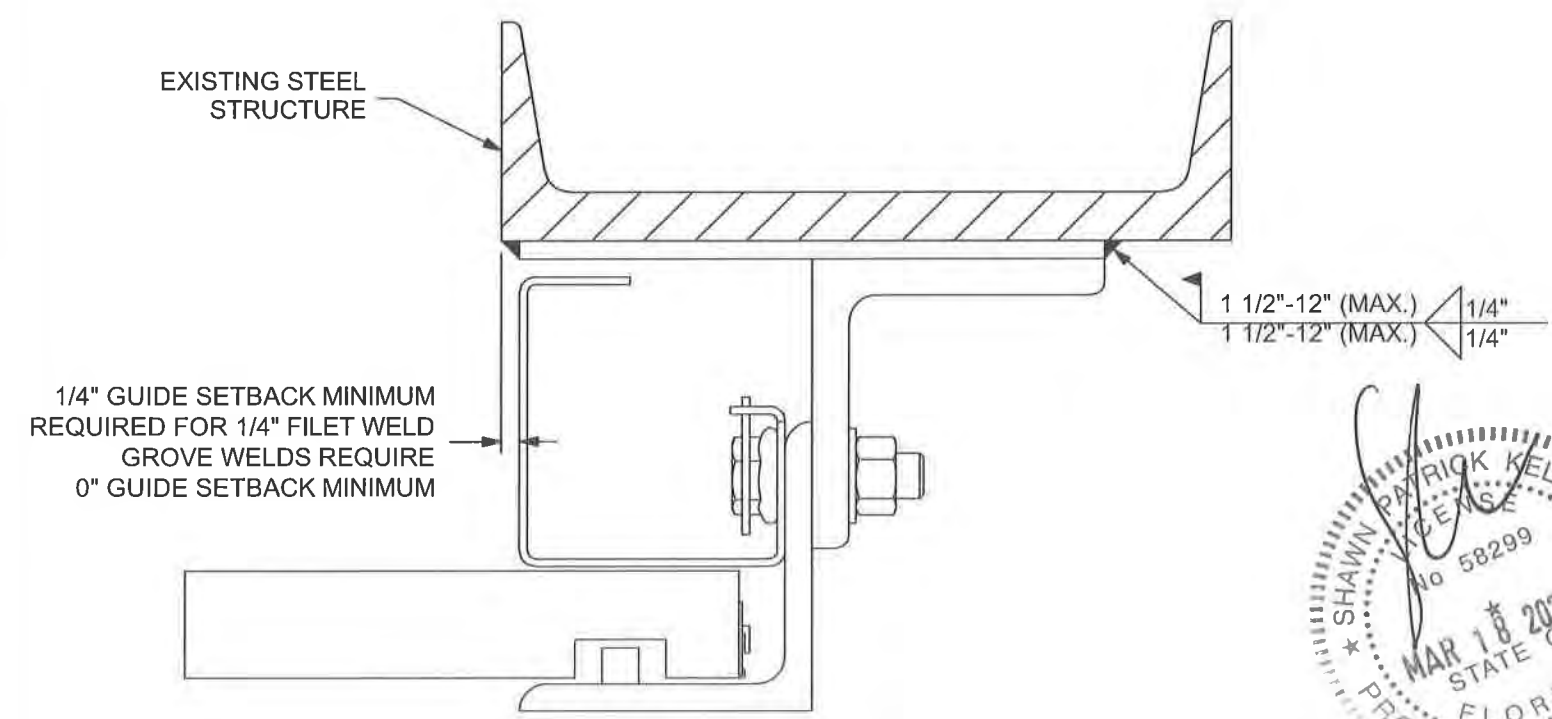

⑥ GUIDE ASSEMBLY - Z GUIDE WELDED TO STEEL STRUCTURE
SCALE 3/8

ANCHOR DETAILS				
DIAMETER	TYPE	MINIMUM NOMINAL EMBEDMENT DEPTH	MINIMUM EFFECTIVE EMBEDMENT DEPTH	MAXIMUM SPACING
1/2"	HILTI KWIK BOLT TZ CARBON OR STAINLESS STEEL	3 5/8"	3 1/4"	6"
	ITW RED HEAD TRUBOLT+ CARBON STEEL	3 3/4"	3 1/4"	
	HILTI KH-EZ CARBON STEEL	4 1/4"	3.22"	
5/8"	HILTI KWIK BOLT TZ CARBON OR STAINLESS STEEL	4 7/16"	4"	12"
	ITW RED HEAD TRUBOLT+ CARBON STEEL	4 5/8"	4"	
	HILTI KH-EZ CARBON STEEL	5"	3.88"	



	24 ELMWOOD AVE 1901 S. LITCHFIELD RD MOUNTAINTOP, PA GOODYEAR, AZ	Unless otherwise specified, dimensions are in inches & tolerances are: 0.000 = +/- 0.031 FRACTIONAL = +/- 1/32 ANGLES = +/- 1/2 DEG
	P: 800.233.8366 F: 800.526.0841 E: ADS@CORNELLIRON.COM	
TITLE: MIAMI DADE COUNTY APPROVED STORMDEFENDER NON-INSULATED ROLLING STEEL DOOR 200 PSF 80 FPS		DRAWN BY: TJE SIZE: B SCALE: AS NOTED SHEET: 3/7
		DWG NO: ES-16-79-CIW

L'TR	REVISION	DATE	BY	E.C.O.
*	ORIGINAL ISSUE	10/02/2018	TJE	1853
A	REVISED TITLE BLOCK; HOOD SUPPORT UPDATE	02/06/2020	MAN	2026

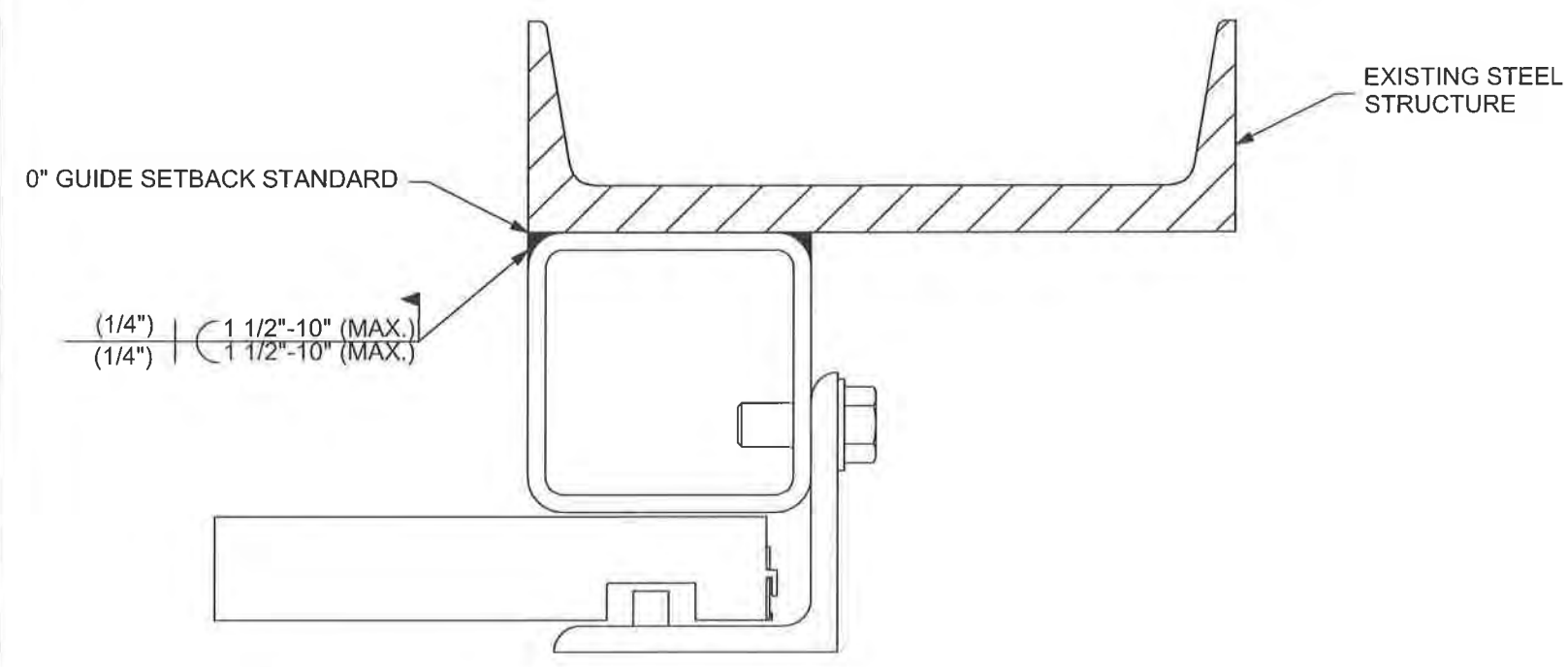

7 GUIDE ASSEMBLY - BOX GUIDE WELDED TO STEEL STRUCTURE
SCALE 3/8

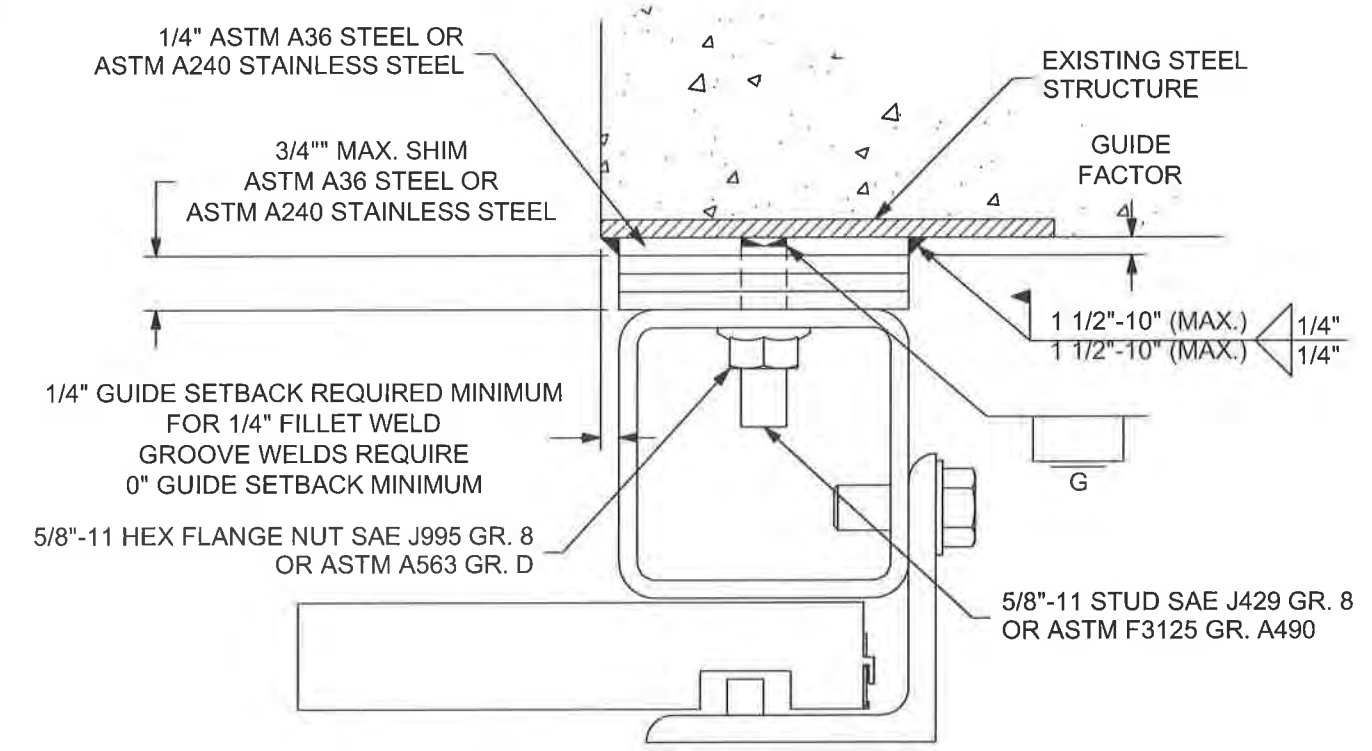

8 GUIDE ASSEMBLY - BOX GUIDE TO STEEL STRUCTURE WITH STUD PLATE
SCALE 3/8

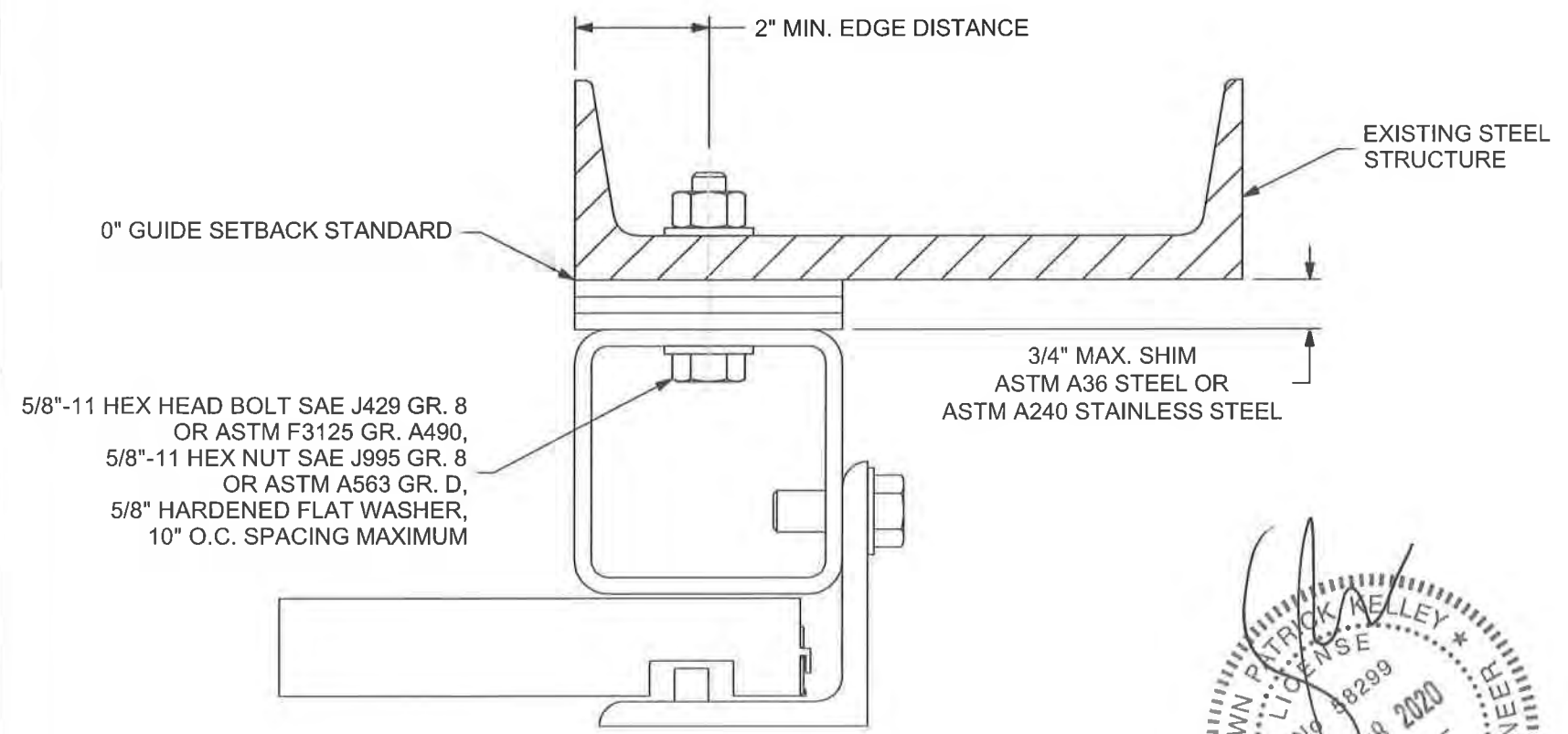

9 GUIDE ASSEMBLY - BOX GUIDE BOLTED TO STEEL STRUCTURE
SCALE 3/8



PRODUCT REVISED
as complying with the Florida Building Code
NOA-No. 20-0925.14
Expiration Date 01/09/2025
By *[Signature]*
Miami-Dade Product Control

	24 ELMWOOD AVE 1901 S. LITCHFIELD RD MOUNTAINTOP, PA GOODYEAR, AZ P: 800.233.8366 F: 800.526.0841 E: ADS@CORNELLIRON.COM	Unless otherwise specified, dimensions are in inches & tolerances are: 0.000 = +/- 0.031 FRACTIONAL = +/- 1/32 ANGLES = +/- 1/2 DEG		
	TITLE: MIAMI DADE COUNTY APPROVED STORMDEFENDER NON-INSULATED ROLLING STEEL DOOR 200 PSF 80 FPS	DRAWN BY: TJE SIZE: B SCALE: AS NOTED SHEET: 4/7	DWG NO: ES-16-79-CIW	

L'TR	REVISION	DATE	BY	E.C.O.
*	ORIGINAL ISSUE	10/02/2018	TJE	1853
A	REVISED TITLE BLOCK; HOOD SUPPORT UPDATE	02/06/2020	MAN	2026

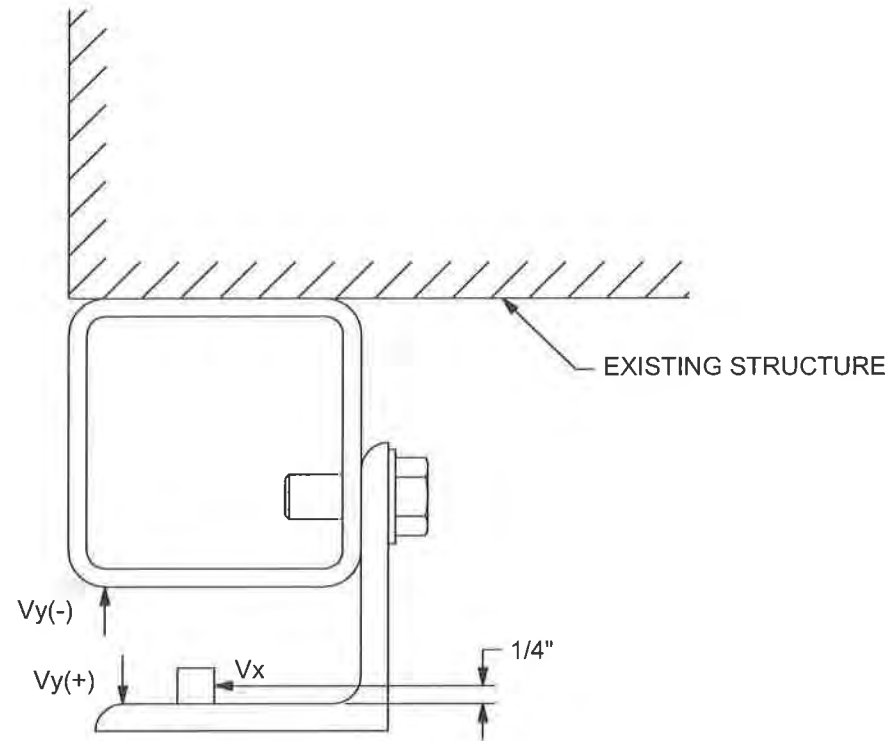

10 SUPERIMPOSED LOAD DIAGRAM - BOX GUIDE
SCALE 3/8

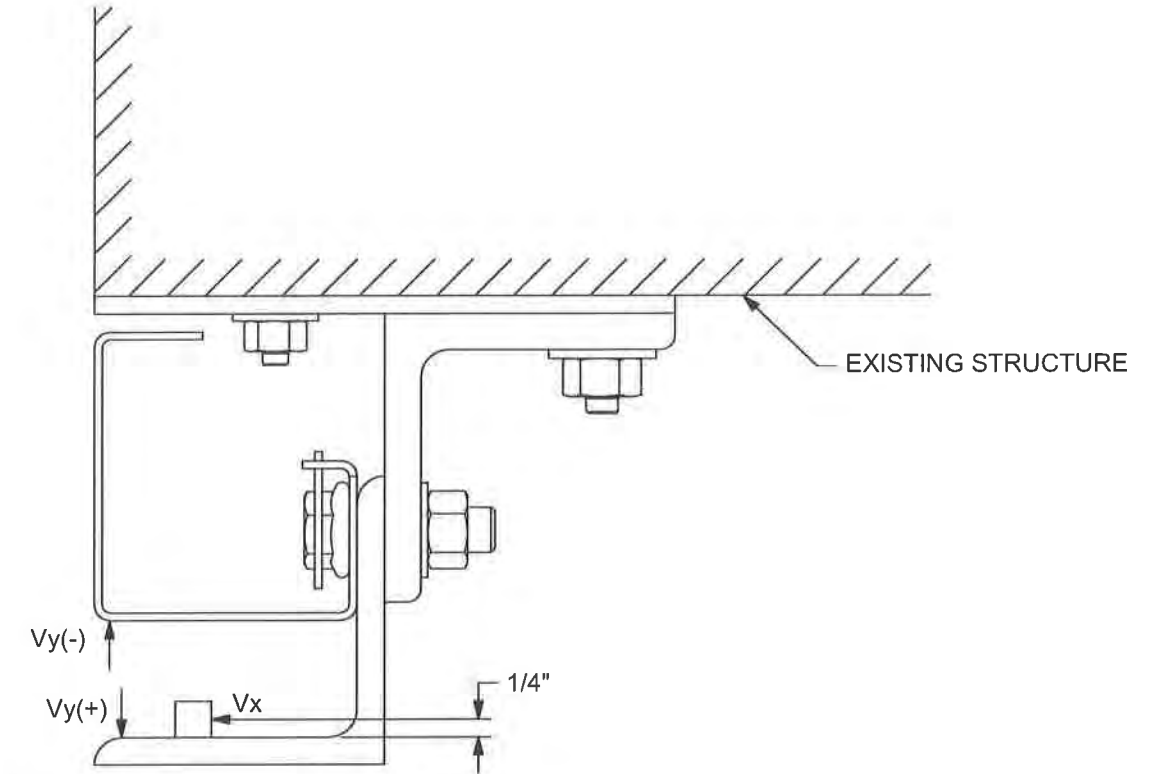

11 SUPERIMPOSED LOAD DIAGRAM - Z GUIDE
SCALE 3/8

UNREDUCED WIND FORCES (LBS PER FOOT OF HEIGHT)	
Vy(+)	1400
Vy(-)	1400
Vx	0

Vx & Vy ARE THE HORIZ. AND VERT. COMPONENTS OF THE REACTION, RESPECTIVELY, RESULTING FROM WIND LOADS ON THE ROLL-UP DOOR. THE EXISTING STRUCTURE SHALL BE CAPABLE OF RESISTING Vx & Vy FORCES SHOWN AND THE CORRESPONDING REACTIONS DUE TO THE ECCENTRICITIES OF THE FORCES.



PRODUCT REVISED
as complying with the Florida Building Code
NOA-No. 20-0925.14

Expiration Date 01/09/2025

By *[Signature]*
Miami-Dade Product Control

	24 ELMWOOD AVE 1901 S. LITCHFIELD RD MOUNTAINTOP, PA GOODYEAR, AZ	Unless otherwise specified, dimensions are in inches & tolerances are: 0.000 = +/- 0.031 FRACTIONAL = +/- 1/32 ANGLES = +/- 1/2 DEG
	P: 800.233.8366 F: 800.526.0841 E: ADS@CORNELLIRON.COM	
TITLE: MIAMI DADE COUNTY APPROVED STORMDEFENDER NON-INSULATED ROLLING STEEL DOOR 200 PSF 80 FPS	DRAWN BY: TJE DWG NO: ES-16-79-CIW	SIZE: B SCALE: AS NOTED SHEET: 5/7

L'TR	REVISION	DATE	BY	E.C.O.
*	ORIGINAL ISSUE	10/02/2018	TJE	1853
A	REVISED TITLE BLOCK; HOOD SUPPORT UPDATE	02/06/2020	MAN	2026

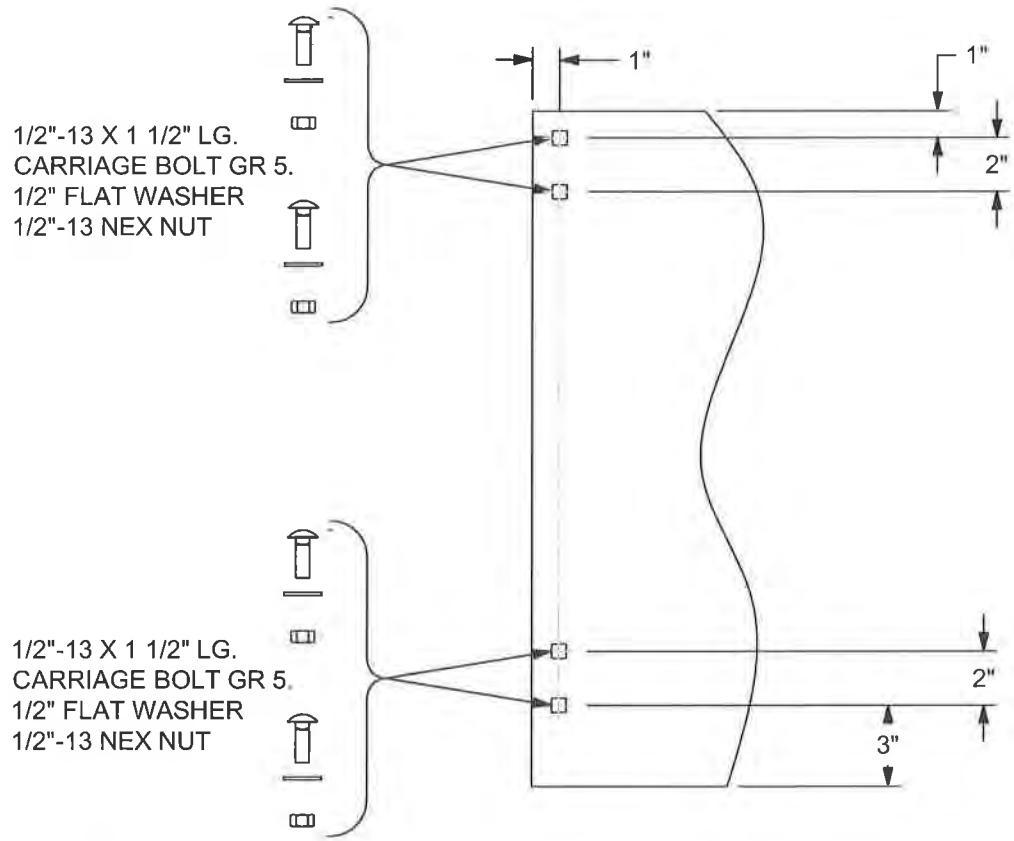

12 BRACKET MOUNTING DETAIL
0.375 MIN. ASTM A36 STEEL OR
ASTM A240 STAINLESS STEEL
SCALE NTS

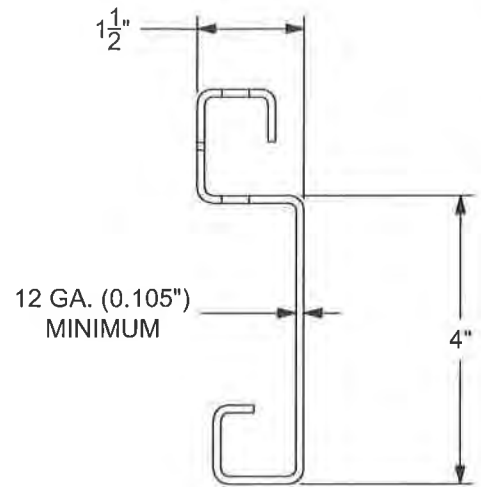

13 SLAT DETAIL
TYPICAL SECTION
SEE NOTE 6.1 FOR MATERIAL SPECIFICATIONS
SCALE 3/8

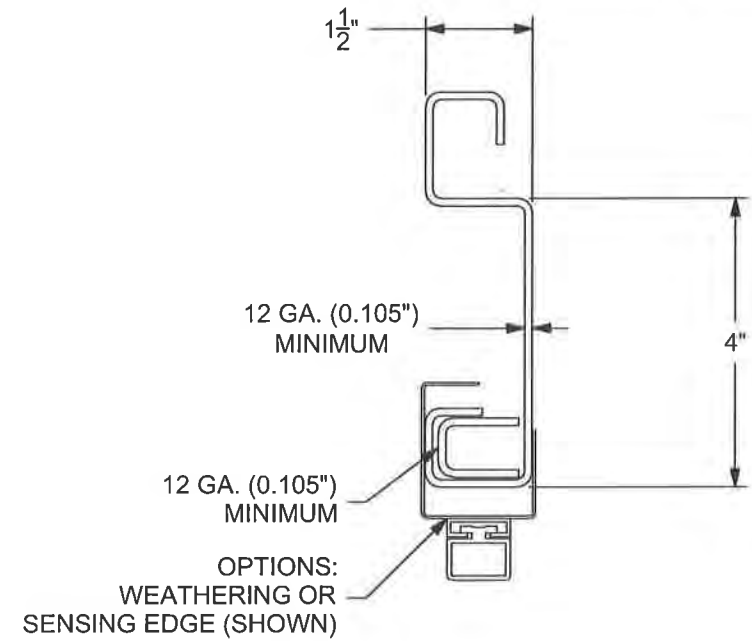

14 BOTTOM BAR DETAIL
TYPICAL SECTION
SEE NOTE 6.1 FOR MATERIAL SPECIFICATIONS
SCALE 3/8

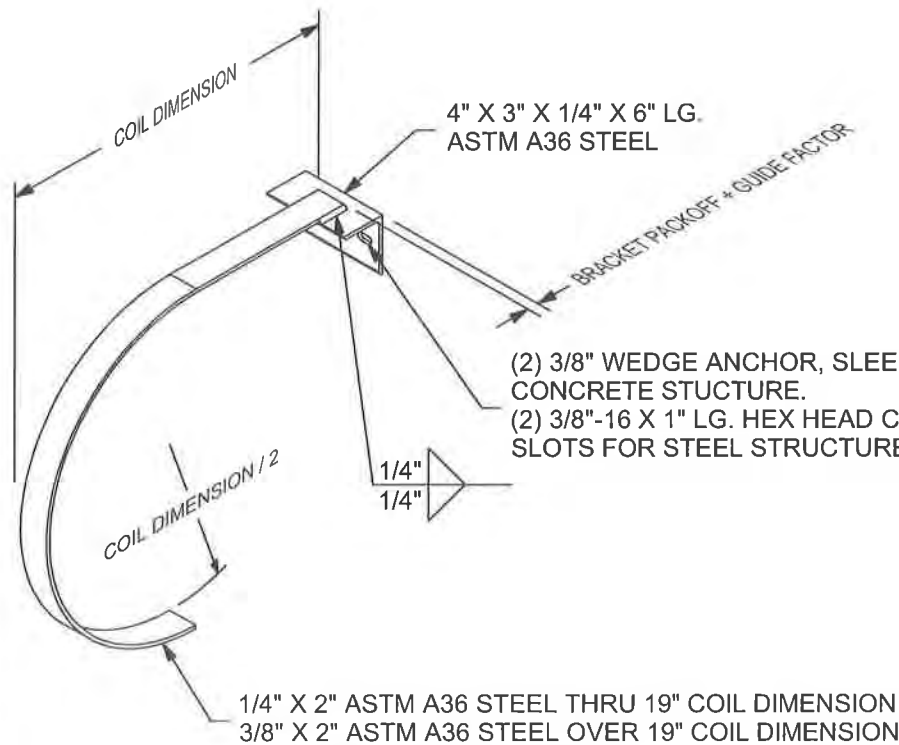

15 MID-HOOD SUPPORT
(WHEN REQUIRED)
"D" SHAPE DEPICTED, SQUARE STYLE ALSO AVAILABLE
SCALE 3/32

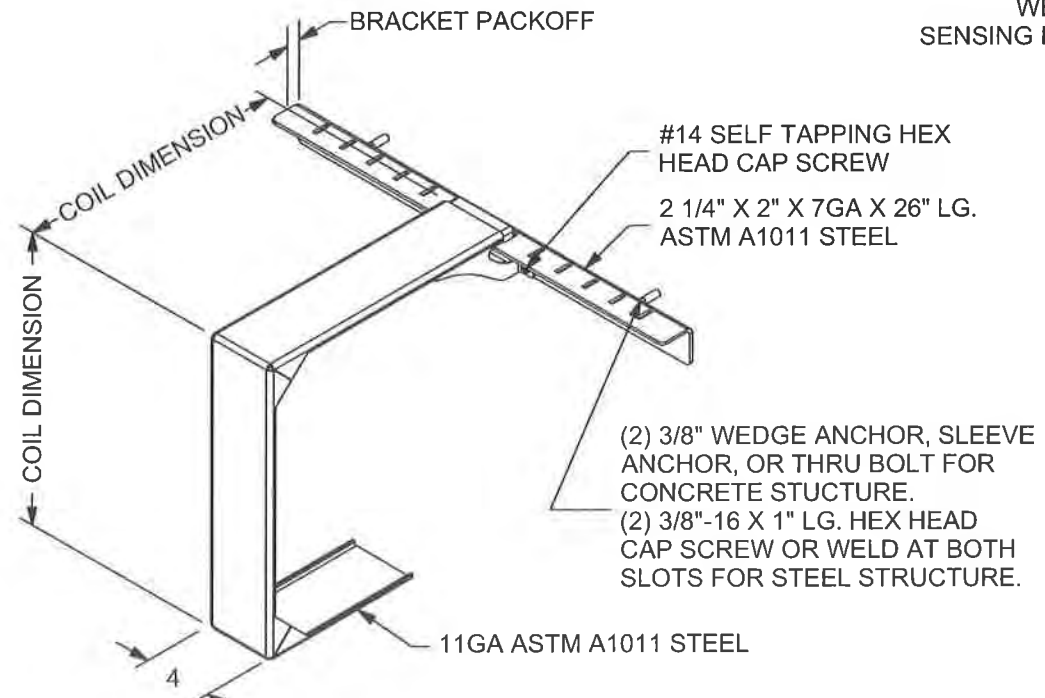

16 MID-HOOD SUPPORT
(WHEN REQUIRED)
SQUARE STYLE DEPICTED, "D" SHAPE ALSO AVAILABLE
SCALE 3/32

NOTES:
6.1 SHEET MATERIAL: ASTM A1011 CS TYPE B (MINIMUM 40 KSI YIELD), SS GRADE 40, HSLAS GRADE 40, HSLAS-F GRADE 40 OR ASTM A666 TYPE 304, 316, 430, OR 201 STAINLESS STEEL (MINIMUM 40 KSI YIELD)

PRODUCT REVISED
as complying with the Florida
Building Code
NOA-No. 20-0925.14
Expiration Date 01/09/2025
By *[Signature]*
Miami-Dade Product Control



	24 ELMWOOD AVE 1901 S. LITCHFIELD RD MOUNTAINTOP, PA GOODYEAR, AZ	Unless otherwise specified, dimensions are in inches & tolerances are: 0.000 = +/- 0.031 FRACTIONAL = +/- 1/32 ANGLES = +/- 1/2 DEG
	P: 800.233.8366 F: 800.526.0841 E: ADS@CORNELLIRON.COM	TITLE: MIAMI DADE COUNTY APPROVED STORMDEFENDER NON-INSULATED ROLLING STEEL DOOR 200 PSF 80 FPS

L'TR	REVISION	DATE	BY	E.C.O.
*	ORIGINAL ISSUE	10/02/2018	TJE	1853
A	REVISED TITLE BLOCK; HOOD SUPPORT UPDATE	02/06/2020	MAN	2026

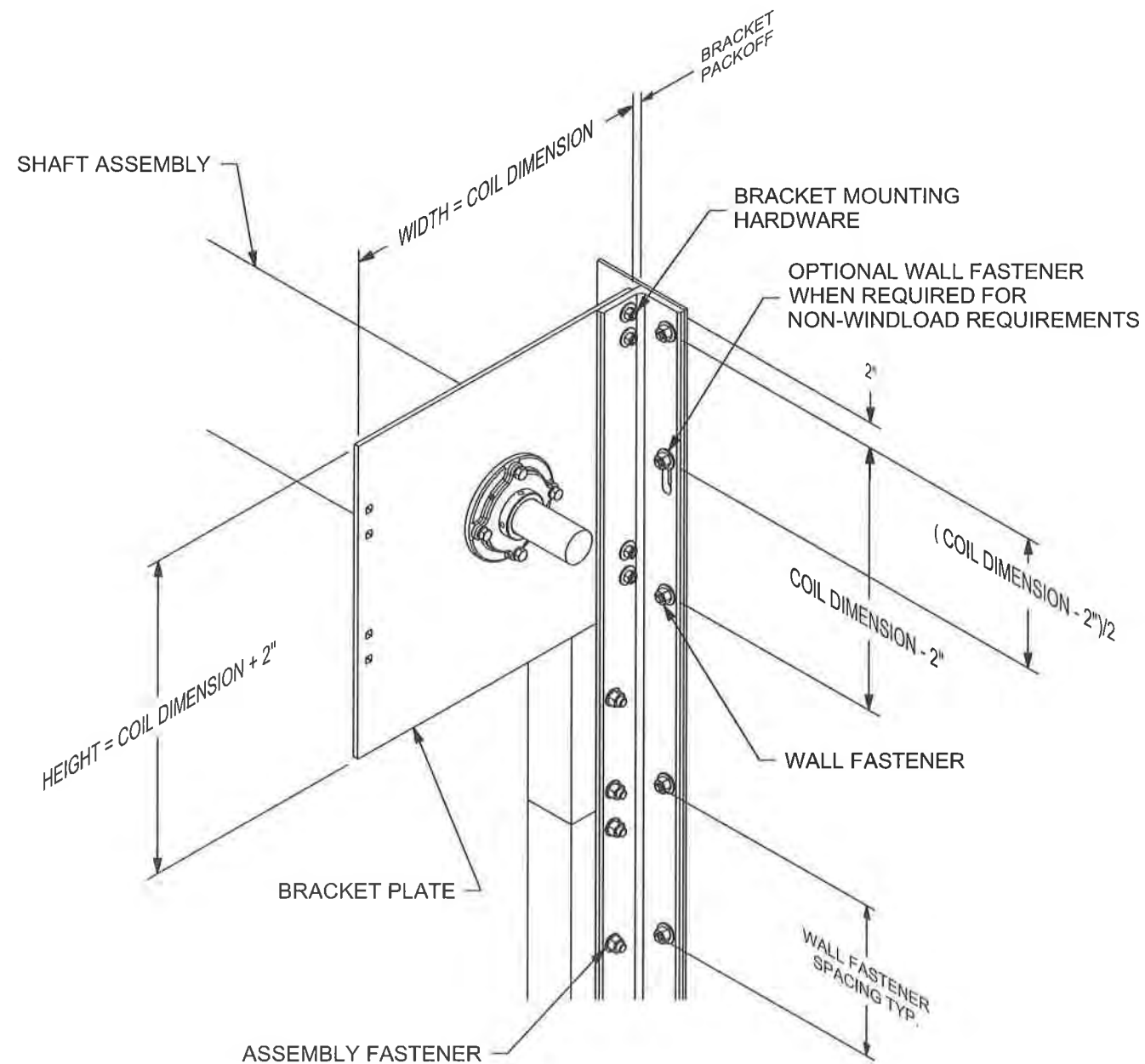

17 BRACKET MOUNTING / TOP WALL ANGLE FASTENING - Z GUIDE
 BRACKET MOUNTING PER DETAIL 12 DEPICTED
 OTHER BRACKET MOUNTINGS ARE AVAILABLE
 HEIGHT AND WIDTH DIMENSION MAY INCREASE
 FOR OTHER MOUNTING CONFIGURATIONS
 SCALE NTS

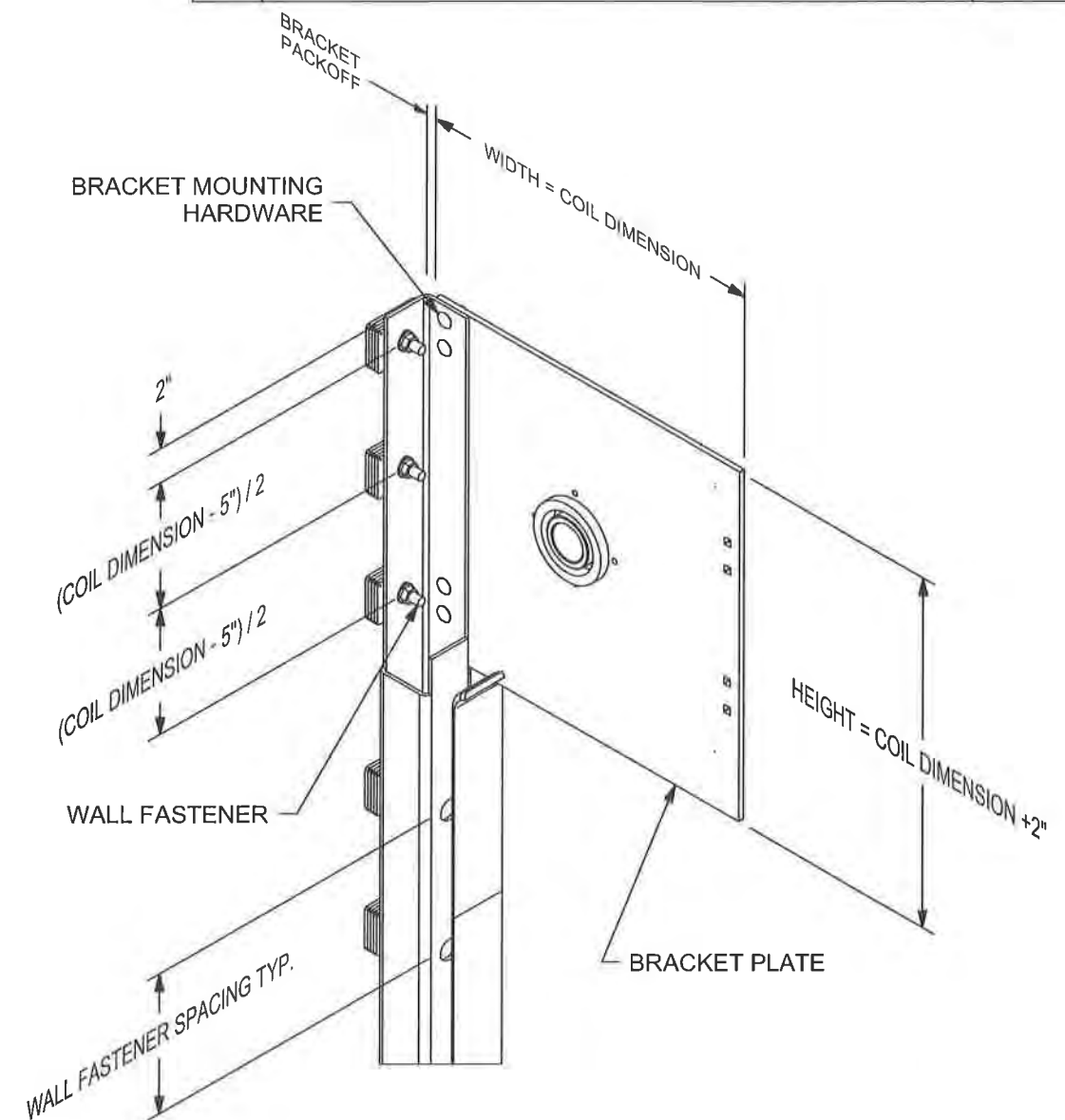

18 BRACKET MOUNTING / TOP TUBE FASTENING - BOX GUIDE
 BRACKET MOUNTING PER DETAIL 12 DEPICTED
 OTHER BRACKET MOUNTINGS ARE AVAILABLE
 HEIGHT AND WIDTH DIMENSION MAY INCREASE
 FOR OTHER MOUNTING CONFIGURATIONS
 SHAFT AND ASSEMBLY FASTENERS NOT SHOWN. SEE DETAIL 16
 SCALE NTS

PRODUCT REVISED
 as complying with the Florida
 Building Code
 NOA-No. 20-0925.14
 Expiration Date 01/09/2025
 By *[Signature]*
 Miami-Dade Product Control



CORNELL
 Innovative door solutions™

24 ELMWOOD AVE 1901 S. LITCHFIELD RD
 MOUNTAINTOP, PA GOODYEAR, AZ
 P: 800.233.8366
 F: 800.526.0841
 E: ADS@CORNELLIRON.COM

Unless otherwise specified,
 dimensions are in inches &
 tolerances are:
 0.000 = +/- 0.031
 FRACTIONAL = +/- 1/32
 ANGLES = +/- 1/2 DEG

TITLE: MIAMI DADE COUNTY APPROVED
 STORMDEFENDER NON-INSULATED
 ROLLING STEEL DOOR 200 PSF 80 FPS

DRAWN BY: TJE
 SIZE: B
 SCALE: AS NOTED
 SHEET: 7/7
 DWG NO: ES-16-79-CIW