



DEPARTMENT OF REGULATORY AND ECONOMIC RESOURCES (RER)
BOARD AND CODE ADMINISTRATION DIVISION

MIAMI-DADE COUNTY
PRODUCT CONTROL SECTION
11805 SW 26 Street, Room 208
Miami, Florida 33175-2474
T (786) 315-2590 F (786) 315-2599
www.miamidade.gov/economy

NOTICE OF ACCEPTANCE (NOA)

Boral Roofing, LLC
7575 Irvine Center Drive, Suite 100
Irvine, CA 92618

SCOPE:

This NOA is being issued under the applicable rules and regulations governing the use of construction materials. The documentation submitted has been reviewed and accepted by Miami-Dade County RER - Product Control Section to be used in Miami-Dade County and other areas where allowed by the Authority Having Jurisdiction (AHJ).

This NOA shall not be valid after the expiration date stated below. The Miami-Dade County Product Control Section (in Miami-Dade County) and/or the AHJ (in areas other than Miami-Dade County) reserve the right to have this product or material tested for quality assurance purposes. If this product or material fails to perform in the accepted manner, the manufacturer will incur the expense of such testing and the AHJ may immediately revoke, modify, or suspend the use of such product or material within their jurisdiction. RER reserves the right to revoke this acceptance, if it is determined by Miami-Dade County Product Control Section that this product or material fails to meet the requirements of the applicable building code.

This product is approved as described herein, and has been designed to comply with the Florida Building Code including the High Velocity Hurricane Zone of the Florida Building Code.

DESCRIPTION: Boral Villa 900 Concrete Roof Tile

LABELING: Each unit shall bear a permanent label with the manufacturer's name or logo, city, state and following statement: "Miami-Dade County Product Control Approved", unless otherwise noted herein.

RENEWAL of this NOA shall be considered after a renewal application has been filed and there has been no change in the applicable building code negatively affecting the performance of this product.

TERMINATION of this NOA will occur after the expiration date or if there has been a revision or change in the materials, use, and/or manufacture of the product or process. Misuse of this NOA as an endorsement of any product, for sales, advertising or any other purposes shall automatically terminate this NOA. Failure to comply with any section of this NOA shall be cause for termination and removal of NOA.

ADVERTISEMENT: The NOA number preceded by the words Miami-Dade County, Florida, and followed by the expiration date may be displayed in advertising literature. If any portion of the NOA is displayed, then it shall be done in its entirety.

INSPECTION: A copy of this entire NOA shall be provided to the user by the manufacturer or its distributors and shall be available for inspection at the job site at the request of the Building Official.

This NOA renews and revises NOA# 21-0420.02 and consists of pages 1 through 7. The submitted documentation was reviewed by Alex Tigera.

Alex Tigera
11/29/21



NOA No.: 21-0712.03
Expiration Date: 09/21/26
Approval Date: 09/16/21
Page 1 of 7

ROOFING ASSEMBLY APPROVAL

Category: Roofing
Sub Category: Roofing Tiles
Material: Concrete

1. SCOPE

This renews a system using **Boral Villa 900 Concrete Roof Tile**, as manufactured Boral Roofing, LLC in Lake Wales, FL and described in Section 2 of this Notice of Acceptance. For locations where the pressure requirements, as determined by applicable Building Code, do not exceed the design pressure values obtained by calculations in compliance with RAS 127 using the values listed in section 4 herein. The attachment calculations shall be done as a moment based system.

2. PRODUCT DESCRIPTION

<u>Manufactured by Applicant</u>	<u>Dimensions</u>	<u>Test Specifications</u>	<u>Product Description</u>
Boral Roofing Villa 900	Length = 17" Width = 13" ½" thick	TAS 112 Type 1b Class III	Low profile, interlocking, high pressure extruded concrete roof tile equipped with three nail holes and double rolls. For direct deck, batten, mortar or adhesive set applications.
Trim Pieces	l = varies w = varies varying thickness	TAS 112	Accessory trim, concrete roof pieces for use at ridges, hips and rakes.

2.1 PRODUCTS MANUFACTURED BY OTHERS

<u>Product Name</u>	<u>Product Description</u>	<u>Manufacturer (With Current NOA)</u>
ICP Adhesives Polyset® AH-160	Two component polyurethane foam adhesive.	ICP Adhesives and Sealants, Inc.
TILE BOND™ Roof Tile Adhesive	Single component polyurethane foam roof tile adhesive.	DuPont de Nemours, Inc.
“Tile Tite” Roof Tile Mortar	Premixed, pre-bagged roof tile mortar.	Bermuda Roof Co. Inc.
Touch ‘N Seal StormBond® 2 Two-Component Polyurethane Roof Tile Adhesive	Two component polyurethane foam adhesive.	DAP Foam, Inc.
Touch ‘N Seal StormBond® One Component Polyurethane Roof Tile Adhesive	One component polyurethane foam adhesive.	DAP Foam, Inc.

2.2 MANUFACTURING LOCATION

2.2.1. Lake Wales, FL



NOA No.: 21-0712.03
Expiration Date: 09/21/26
Approval Date: 09/16/21
Page 2 of 7

2.3 EVIDENCE SUBMITTED

<u>Test Agency</u>	<u>Test Identifier</u>	<u>Test Name/Report</u>	<u>Date</u>
Nutting Engineers	13343.1	TAS 112	Apr. 2006
Redland Technologies	7161-03	Static Uplift Testing	Dec. 1991
	Appendix III 7161-03	TAS 102 & TAS 102(A) Wind Tunnel Testing	Dec. 1991
	Appendix II P0402	TAS 108 (Nail-On) Withdrawal Resistance Testing of screw vs. smooth shank nails	Sept. 1993
The Center for Applied Engineering, Inc.	94-060B	Static Uplift Testing TAS 101 (Adhesive Set)	March, 1994
	94-084	Static Uplift Testing TAS 101 (Mortar Set)	May 1994
Redland Technologies	P0631-01	Wind Tunnel Testing TAS 108 (Mortar Set)	July 1994
	Letter Dated Aug. 1, 1994	Wind Tunnel Testing TAS 108 (Nail-On)	Aug. 1994
The Center for Applied Engineering, Inc.	Project No. 307025	Wind Driven Rain	Oct. 1994
	Test #MDC-76	TAS 100	
	25-7183-1	Static Uplift Testing	Feb. 1995
	25-7183-2	TAS 102	
	25-7214-2	(2 Quik-Drive Screws, Direct Deck) Static Uplift Testing	March, 1995
	25-7214-6	TAS 102 (1 Quik-Drive Screw, Direct Deck) (1 Quik-Drive Screw, Battens)	
Celotex Corporation Testing Services	528454-2-1	Static Uplift Testing	Sep. 1998
	520109-2	TAS 101	Dec. 1998
Walker Engineering, Inc.	Evaluation Calculations	25-7183	March 1995
	Evaluation Calculations	25-7094	February 1996
	Evaluation Calculations	25-7496	April 1996
	Evaluation Calculations	25-7584	December 1996
		25-7804b-8	
		25-7804-4 & 5	
		25-7848-6	
	Evaluation Calculations	Aerodynamic Multipliers	09/01/16
Evaluation Calculations	Two Patty Adhesive Set System	April 1999	
Evaluation Calculations	Restoring Moment Due to Gravity	09/01/16	
American Test Lab of South Florida	RT0617.02-16	TAS 112	06/29/16
	RT0503.02-21	TAS 112	05/12/21



PRI Construction Materials Technologies	COPO-002-02-11	Static Uplift Testing TAS 101 (Adhesive Set)	10/12/2016
	COPO-002-02-04	Static Uplift Testing TAS 101 (Adhesive Set)	10/12/2016
	COPO-002-02-03	Static Uplift Testing TAS 101 (Adhesive Set)	10/12/2016
	2002T003.02	TAS 101	11/06/20
NEMO ETC, LLC	4c-DPBS-20-LSOTM-01.C.R1	TAS 101	12/17/20

3. LIMITATIONS:

- 3.1 Fire classification is not part of this acceptance.
- 3.2 For mortar or adhesive set tile applications, a static field uplift test shall be performed in accordance with TAS 106.
- 3.3 Applicant shall retain the services of a Miami-Dade County Certified Laboratory to perform quarterly test in accordance with TAS 112, appendix ‘A’. Such testing shall be submitted to the Building Code Compliance Office for review.
- 3.4 Minimum underlayment shall be in compliance with the applicable Roofing Applications Standards listed section 4.1 herein.
- 3.5 30/90 hot mopped underlayment applications may be installed perpendicular to the roof slope unless stated otherwise by the underlayment material manufacturers published literature.
- 3.6 This acceptance is for wood deck applications. Minimum deck requirements shall be in compliance with applicable building code.

4. INSTALLATION

- 4.1 Villa 900 Concrete Roof Tile and its components shall be installed in strict compliance with Roofing Application Standard RAS 118, RAS 119, and RAS 120.
- 4.2 Data For Attachment Calculations

Table 1: Average Weight (W) and Dimensions (l x w)			
Tile Profile	Weight-W (lbf)	Length-l (ft)	Width-w (ft)
Villa 900 Concrete Tile	10.90	1.42	1.08

Table 2: Aerodynamic Multipliers - λ (ft³)		
Tile Profile	λ (ft³) Batten Application	λ (ft³) Direct Deck Application
Villa 900 Concrete Tile	0.291	0.315



Table 3: Restoring Moments due to Gravity - M_g (ft.-lbf.)										
Tile Profile	2":12"	3":12"	4":12"		5":12"		6":12"		7":12" or greater	
Villa 900 Concrete Tile	Direct Deck	Direct Deck	Battens	Direct Deck	Battens	Direct Deck	Battens	Direct Deck	Battens	Direct Deck
	7.70	7.62	6.56	7.50	6.42	7.34	6.26	7.15	6.08	6.95

Table 4: Attachment Resistance Expressed as a Moment - M_r (ft-lbf) for Mechanically Fastened Systems				
Tile Profile	Fastener Type	Direct Deck (min 15/32" plywood)	Direct Deck (min. 19/32" plywood)	Battens
Villa 900 Concrete Tile	2-10d Ring Shank Nails	27.8	37.4	28.8
	1-10d Smooth or Screw Shank Nail	8.8	11.8	4.1
	2-10d Smooth or Screw Shank Nails	16.4	21.9	7.1
	1 #8 Screw	25.8	25.8	22.9
	2 #8 Screw	47.1	47.1	49.1
	1-10d Smooth or Screw Shank Nail (Field Clip)	24.3	24.3	24.2
	1-10d Smooth or Screw Shank Nail (Eave Clip)	19.0	19.0	22.1
	2-10d Smooth or Screw Shank Nails (Field Clip)	35.5	35.5	34.8
2-10d Smooth or Screw Shank Nails (Eave Clip)	31.9	31.9	32.2	

Table 5: Attachment Resistance Expressed as a Moment M_r (ft-lbf) for Two Paddy Adhesive¹ Set Systems		
Tile Profile	Tile Application	Minimum Attachment Resistance
Villa 900 Concrete Tile	TILE BOND™ Roof Tile Adhesive	35 ²
	TILE BOND™ Roof Tile Adhesive	67 ³
	ICP Adhesives Polyset® AH-160	26.1 ⁴
	Touch 'N Seal StormBond® 2	55 ⁵
	Touch 'N Seal StormBond® (one component)	72 ⁶

- 1 See foam adhesive manufacturer's component approval for installation requirements.
- 2 Medium paddy weight of 8 grams per paddy of TILE BOND™ Roof Tile Adhesive
- 3 Medium paddy weight of 16 grams per paddy of TILE BOND™ Roof Tile Adhesive
- 4 Medium paddy weight of 8 grams per paddy of Polyset® AH-160
- 5 Medium paddy weight of 8 grams per paddy of Touch 'N Seal StormBond® 2
- 6 Medium paddy weight of 8 grams between tile and underlayment, paddy weight of 5 grams on overlap of tile of Touch 'N Seal StormBond® (one component)



**Table 6: Attachment Resistance Expressed as a Moment - M_r (ft-lbf)
for Single Paddy Adhesive Set Systems**

Tile Profile	Tile Application	Minimum Attachment Resistance
Villa 900 Concrete Tile	ICP Adhesives Polyset® AH-160	86.6 ⁷
	ICP Adhesives Polyset® AH-160	45.5 ⁸
	Touch 'N Seal StormBond® 2	40 ⁹
	Touch 'N Seal StormBond® 2	70 ¹⁰
7 Large paddy weight of 54 grams of Polyset® AH-160		
8 Medium paddy weight of 24 grams of Polyset® AH-160		
9 Medium paddy weight of 30 grams of Touch 'N Seal StormBond® 2		
10 Large paddy weight of 60 grams of Touch 'N Seal StormBond® 2		

**Table 7: Attachment Resistance Expressed as a Moment - M_r (ft-lbf)
for Mortar Set Systems**

Tile Profile	Tile Application	Attachment Resistance
Villa 900 Concrete Tile	Mortar Set ¹¹	20.6
11 Bermuda Roof Co. Inc. Tile-Tite Roof Tile Mortar.		

5. LABELING

5.1 All tiles shall bear the imprint or identifiable marking of the manufacturer's name or logo as detailed below, or following statement: "Miami-Dade County Product Control Approved".



**LABEL FOR BORAL VILLA 900 CONCRETE TILE
(LOCATED ON THE UNDERSIDE OF TILE)**

6. BUILDING PERMIT REQUIREMENTS:

6.1 Application for building permit shall be accompanied by copies of the following:

6.1.1 This Notice of Acceptance.

6.1.2 Any other documents required by Building Official or Applicable building code in order to properly evaluate the installation of this system.



PROFILE DRAWING

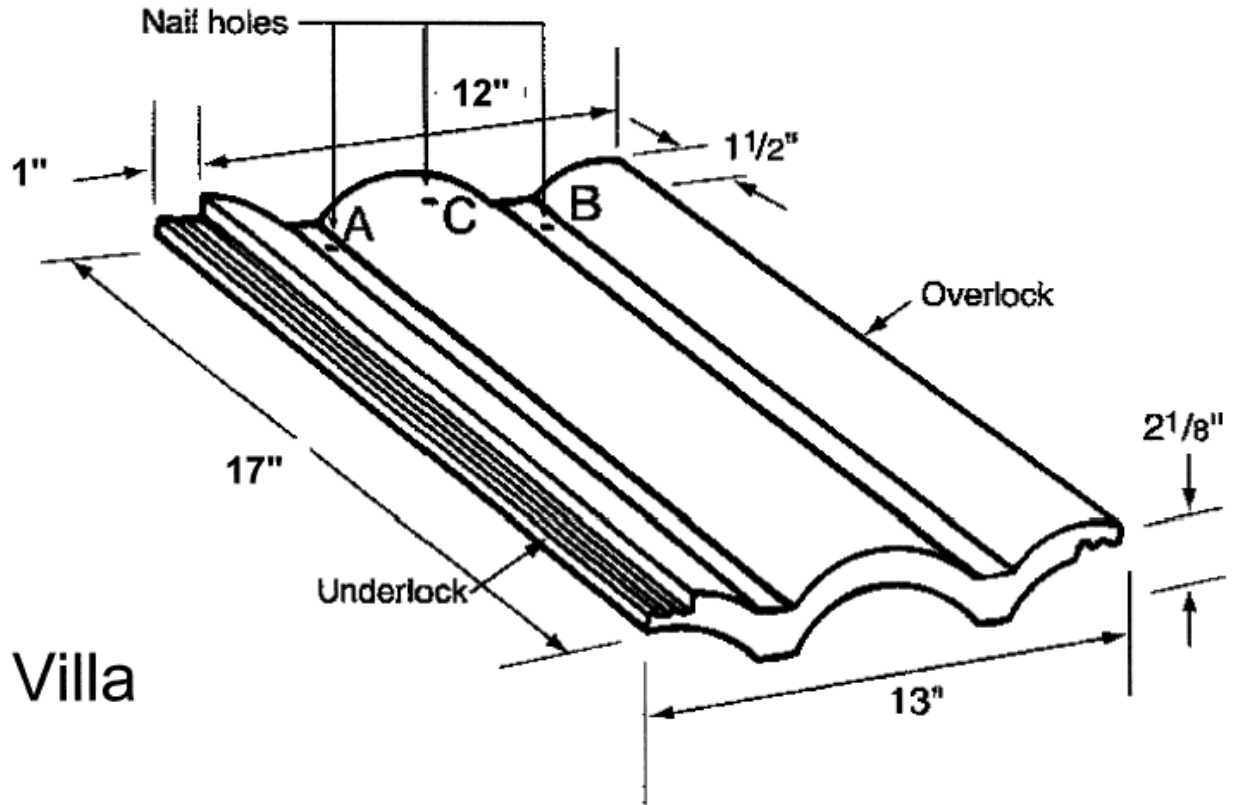

Villa

VILLA 900 CONCRETE ROOF TILE

END OF THIS ACCEPTANCE

