



DEPARTMENT OF REGULATORY AND ECONOMIC RESOURCES (RER)
 BOARD AND CODE ADMINISTRATION DIVISION
NOTICE OF ACCEPTANCE (NOA)

MIAMI-DADE COUNTY
 PRODUCT CONTROL SECTION
 11805 SW 26 Street, Room 208
 Miami, Florida 33175-2474
 T (786) 315-2590 F (786) 315-2599
www.miamidadegov/economy

Clopay Corporation
8585 Duke Boulevard
Mason, OH 45040

SCOPE: This NOA is being issued under the applicable rules and regulations governing the use of construction materials. The documentation submitted has been reviewed and accepted by Miami-Dade County RER-Product Control Section to be used in Miami Dade County and other areas where allowed by the Authority Having Jurisdiction (AHJ). This NOA shall not be valid after the expiration date stated below. The Miami-Dade County Product Control Section (In Miami Dade County) and/or the AHJ (in areas other than Miami Dade County) reserve the right to have this product or material tested for quality assurance purposes. If this product or material fails to perform in the accepted manner, the manufacturer will incur the expense of such testing and the AHJ may immediately revoke, modify, or suspend the use of such product or material within their jurisdiction. RER reserves the right to revoke this acceptance if it is determined by Miami-Dade County Product Control Section that this product or material fails to meet the requirements of the applicable building code.

This product is approved as described herein and has been designed to comply with the Florida Building Code, including the High Velocity Hurricane Zone.

DESCRIPTION: 2” Thick EPS Insulated Steel Sectional Garage Door up to 9’-0” Wide w/ Optional Impact Resistant Lites

APPROVAL DOCUMENT: Drawing No. **101703**, titled “HDG/HDGL, 66/68, 4300/01, 4310/67/HDGL, 4400/01, H Models”, sheet 1 of 1, dated 11/19/1996, with revision 10 dated 08/28/20, prepared by Clopay Corporation, signed and sealed by Mark Westerfield, P.E. on 07/05/2022, bearing the Miami-Dade County Product Control renewal stamp with the Notice of Acceptance number and expiration date by the Miami-Dade County Product Control Section.

MISSILE IMPACT RATING: Large and Small Missile Impact Resistant

LABELING: A permanent label with the manufacturer’s name or logo, manufacturing address, model number, the positive and negative design pressure rating, indicate impact rated if applicable, installation instruction drawing reference number, approval number (NOA), the applicable test standards, and the statement reading ‘Miami-Dade County Product Control Approved’ is to be located on the door’s side track, bottom angle, or inner surface of a panel.

RENEWAL of this NOA shall be considered after a renewal application has been filed and there has been no change in the applicable building code negatively affecting the performance of this product.

TERMINATION of this NOA will occur after the expiration date or if there has been a revision or change in the materials, use, and/or manufacture of the product or process. Misuse of this NOA as an endorsement of any product, for sales, advertising or any other purposes shall automatically terminate this NOA. Failure to comply with any section of this NOA shall be cause for termination and removal of NOA.

ADVERTISEMENT: The NOA number preceded by the words Miami-Dade County, Florida, and followed by the expiration date may be displayed in advertising literature. If any portion of the NOA is displayed, then it shall be done in its entirety.

INSPECTION: A copy of this entire NOA shall be provided to the user by the manufacturer or its distributors and shall be available for inspection at the job site at the request of the Building Official.

This NOA **renews NOA # 20-0922.35** and consists of this page 1 and evidence pages E-1, E-2, E-3 and E-4, as well as approval document mentioned above.

The submitted documentation was reviewed by **Carlos M. Utrera, P.E.**



NOA No. 22-0707.10
Expiration Date: September 20, 2027
Approval Date: August 4, 2022
 Page 1

NOTICE OF ACCEPTANCE: EVIDENCE SUBMITTED

1. Evidence submitted under previous NOA's

A. DRAWINGS

1. Drawing No. **101703**, titled "HDG/HDGL, 66/68, 4300/01, 4310/67/HDGL, 4400/01, H Models", sheet 1 of 1, dated 11/19/1996, with revision 7 dated 2/2015, prepared by Clopay Building Products Company, signed and sealed by Scott Hamilton, P.E.
"Submitted under NOA #15-0225.06"
2. Drawing No. **101703**, titled "HDG/HDGL, 66/68, 4300/01, 4310/67/HDGL, 4400/01, H Models", sheet 1 of 1, dated 11/19/1996, with revision 8 dated 7/2017, prepared by Clopay Building Products Company, signed and sealed by Scott Hamilton, P.E..
"Submitted under NOA #17-0731.01"
3. Drawing No. **101703**, titled "HDG/HDGL, 66/68, 4300/01, 4310/67/HDGL, 4400/01, H Models", sheet 1 of 1, dated 11/19/1996, with revision 9 dated 7/2018, prepared by Clopay Building Products Company, signed and sealed by Scott Hamilton, P.E.
"Submitted under NOA # 18-0716.01"

B. TESTS

1. Test report on Forced Entry Test, per FBC, TAS 202-94, prepared by American Test Lab, Inc., Test Report No. **ATLNC 0428.01-09**, dated 06/03/2009, signed and sealed by David W. Johnson, P.E. **"Submitted under NOA # 09-0929.10"**
2. Test reports on 1) Uniform Static Air Pressure Test, Loading per FBC TAS 202,
2) Large Missile Impact Test, per FBC TAS 201,
3) Cyclic Wind Pressure Test, Loading per FBC TAS 203,
along with marked-up drawings, prepared by American Test Lab, Inc., Test Report No. **ATLNC 0823.01-06**, dated 12/18/2006, signed and sealed by David W. Johnson, P.E.
"Submitted under NOA # 07-0807.14"
3. Test reports on 1) Uniform Static Air Pressure Test, Loading per FBC TAS 202-94
2) Large Missile Impact Test per FBC, TAS 201-94
3) Cyclic Wind Pressure Loading per FBC, TAS 203-94
4) Forced Entry Test, per FBC, TAS 202-94
5) Tensile Test per ASTM E8
along with marked-up drawings and installation diagram of 9'x 8', 27ga steel garage door Model 4300 with windows, prepared by American Test Lab, Inc., Test Report No. **ATLNC 1023-01-17**, dated 11/07/2017, signed and sealed by David W. Johnson, P.E.
"Submitted under NOA # 18-0716.01"
4. Test report on Salt Spray per ASTM B117 of painted G40 galvanized coated panels, prepared by Fenestration Testing Laboratory, Inc., Test Report No. **7890**, dated 10/01/2014, signed by Idalmis Ortega, P.E. **"Submitted under NOA # 18-0716.01"**

C. CALCULATIONS

1. Anchoring calculations, prepared by Clopay Building Products Company, dated 07/30/2007, signed and sealed by Scott Hamilton, P.E. **"Submitted under NOA # 07-0807.14"**
2. Anchoring calculations prepared by Clopay Building Products Company, dated 07/06/2018, signed and sealed by Scott Hamilton, P.E. **"Submitted under NOA # 18-0716.01"**



Carlos M. Utrera, P.E.
Product Control Examiner
NOA No. 22-0707.10
Expiration Date: September 20, 2027
Approval Date: August 4, 2022

NOTICE OF ACCEPTANCE: EVIDENCE SUBMITTED

D. QUALITY ASSURANCE

1. Miami-Dade Department of Regulatory and Economic Resources (RER)

E. MATERIAL CERTIFICATIONS

“Submitted under NOA # 07-0807.14”

1. Tensile Test per ASTM E8, Reports No. **HETI-06-T604/605/606**, prepared by Hurricane Engineering & Testing, Inc, dated 09/22/2006, signed and sealed by Rafael E. Droz-Seda, P.E.
2. Corrosion Resistance Salt Spray Test per ASTM B117, Report No. **30160-04-63365**, prepared by Stork Twin City Testing Corporation, dated 01/26/2005, signed by John D. Lee, P.E.
3. Ignition Properties of Plastics Test, per ASTM D1929, Report No. **3082959-500**, prepared by Intertek Testing Services NA, Inc., dated 09/16/2005, signed by Anthony Penalzoa.
4. Surface Burning Characteristics Test, per ASTM E84, Report No. **3082960-500**, dated 10/04/2005 and Report No. **3094867SAT-001**, dated 04/13/2006, prepared by Intertek Testing Services, NA, Inc., signed by Javier Trevino and Anthony Penalzoa.

“Submitted under NOA # 18-0716.01”

5. Test report on weathering per ASTM G155, tensile per ASTM D638, self-ignition per ASTM D1929, smoke density per ASTM D2843 and rate of burning per ASTM D635 of Lexan SLX2432T polycarbonate, prepared by Intertek, test report # **G7844.01-106-18**, dated 09/28/2017, signed and sealed by Gary T. Hartman, P.E.
6. Test report on self-Ignition per ASTM D1929 of Atlas EPS foam, prepared by Intertek, test report # **102609488MID-002**, dated 06/13/2016, signed and sealed by Rick Curkeet, P.E.
7. Test report on flame spread and smoke developed per ASTM E84, prepared by UL LLC, test report # **R6705/4788441837**, dated 06/06/2018, signed by James Smith.

F. STATEMENTS

1. Statement letter of code conformance with the 2010 and the 5th edition (2014) FBC issued by Clopay Building Products Company, dated 02/18/2015, signed and sealed by Scott Hamilton, P.E. ***“Submitted under NOA #15-0225.06”***
2. Statement letter of code conformance to 2010 FBC no financial interest, issued by Clopay Building Products Company, dated 07/06/2012, signed and sealed by Scott Hamilton, P.E. ***“Submitted under NOA # 12-0710.06”***
3. Statement letter of code conformance to 5th Edition (2014) and 6th Edition (2017) FBC issued by Clopay Building Products Company, dated 07/18/2017, signed and sealed by Scott Hamilton, P.E. ***“Submitted under NOA #17-0731.01”***
4. Test contract letter issued by American Test Lab, Inc., dated 07/17/2017, signed by Keith Owen. ***“Submitted under NOA #17-0731.01”***
5. Statement letter of code conformance with the 2010, 5th edition (2014) and 6th edition (2017) FBC issued by Clopay Building Products Company, dated 07/06/2018, signed and sealed by Scott Hamilton, P.E. ***“Submitted under NOA # 18-0716.01”***
6. Statement letter of no financial interest issued by Clopay Building Products Company, dated 07/06/2018, signed and sealed by Scott Hamilton, P.E. ***“Submitted under NOA # 18-0716.01”***



Carlos M. Utrera, P.E.
Product Control Examiner
NOA No. 22-0707.10
Expiration Date: September 20, 2027
Approval Date: August 4, 2022

NOTICE OF ACCEPTANCE: EVIDENCE SUBMITTED

2. Evidence submitted under NOA # 20-0922.35

A. DRAWINGS

1. Drawing No. **101703**, titled “HDG/HDGL, 66/68, 4300/01, 4310/67/HDGL, 4400/01, H Models”, sheet 1 of 1, dated 11/19/1996, with revision 10 dated 08/28/2020, prepared by Clopay Building Products Company, signed and sealed by Scott Hamilton, P.E.

B. TESTS

1. None.

C. CALCULATIONS

1. None.

D. QUALITY ASSURANCE

1. Miami-Dade Department of Regulatory and Economic Resources (RER).

E. MATERIAL CERTIFICATIONS

1. None.

F. STATEMENTS

1. Statement letter of code conformance with 6th edition (2017) FBC and 7th edition (2020) issued by Clopay Building Products Company, dated 09/15/2020, signed and sealed by Scott Hamilton, P.E.
2. Statement letter of no financial interest issued by Clopay Building Products Company, dated 09/15/2020, signed and sealed by Scott Hamilton, P.E.



Carlos M. Utrera, P.E.
Product Control Examiner
NOA No. 22-0707.10
Expiration Date: September 20, 2027
Approval Date: August 4, 2022

NOTICE OF ACCEPTANCE: EVIDENCE SUBMITTED

3. New evidence submitted

A. DRAWINGS

1. Drawing No. **101703**, titled “HDG/HDGL, 66/68, 4300/01, 4310/67/HDGL, 4400/01, H Models”, sheet 1 of 1, dated 11/19/1996, with revision 10 dated 08/28/2020, prepared by Clopay Corporation, signed and sealed by Mark Westerfield, P.E. on 07/05/2022.

B. TESTS

1. None.

C. CALCULATIONS

1. None.

D. QUALITY ASSURANCE

1. Miami-Dade Department of Regulatory and Economic Resources (RER).

E. MATERIAL CERTIFICATIONS

1. None.

F. STATEMENTS

1. Statement letter of code conformance with 7th edition (2020) of the FBC, issued by Clopay Corporation, dated 07/05/2022, signed and sealed by Mark Westerfield, P.E.
2. Statement letter of no financial interest issued by Clopay Corporation, dated 07/05/2022, signed and sealed by Mark Westerfield, P.E.



Carlos M. Utrera, P.E.
Product Control Examiner
NOA No. 22-0707.10
Expiration Date: September 20, 2027
Approval Date: August 4, 2022

CLOPAY MODELS 4300, 4301, 4310, 4400, 4401, HDG, HDGL
 CLOPAY MODELS H400, H401, H300, H301, H310
 HOLMES MODELS 66, 67, 68, 6200, 6201, 6203

REV	DATE	DESCRIPTION
1	7-8-97	ADDED MAXIMUM VENT OPENING
2	4/2001	ADD HOLMES MODELS & HDGL; DELETE MODELS 2200, 2201, 2300, 2301, 4200; G-40 MIN. WAS G-60
3	4/2003	ADD "H" MODELS; DELETE M/N 2400/01; 27 GA. ON 4310/HDGL
4	7/31/2006	ADDED OPTIONAL LITES; CLARIFIED END STILE SCREW AND BACKER PLATES; MIN. YIELD WAS 27 KSI.
5	1/2012	AFFIRMED COMPLIANCE WITH 2010 FBC
6	7/2012	INCREASED MAXIMUM HEIGHT; ADDED HOLMES 62XX MODELS.
7	2/2015	UPDATED CODE COMPLIANCE STATEMENT.
8	7/2017	UPDATED CODE COMPLIANCE STATEMENT; INCLUDE 6TH Ed FBC.
9	3/3/20	REVISED MAX WINDOW SIZE AND TITLE BLOCK
10	8/28/20	UPDATED CODE OF COMPLIANCE STATEMENT TO 7TH EDITION

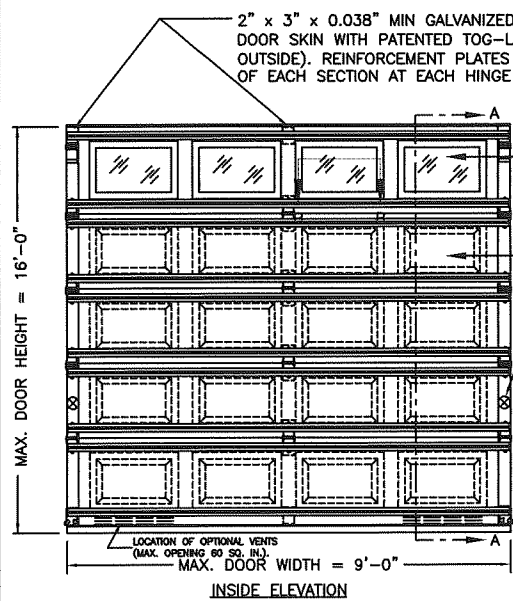

OPTIONAL: ONE ROW OF IMPACT-RESISTANT GLAZING IN EITHER TOP SECTION (SHOWN) OR NEXT-TO-THE-TOP SECTION (NOT SHOWN). MAX. GLAZING SIZE IS 19-1/2" x 12". GLAZING IS INJECTION MOLDED GE LEXAN SLX2432T, AN APPROVED CC2 PLASTIC IN ACCORDANCE WITH IBC/FBC 2606. SEE SECTION B-B FOR ASSEMBLY DETAILS.

TABLE 1

DOOR HEIGHT	# OF SECTIONS
UP TO 7'0"	4
7'3" TO 8'9"	5
9'0" TO 10'6"	6
10'9" TO 12'3"	7
12'6" TO 14'0"	8
14'3" TO 15'9"	9
16'0"	10

MAX SECTION HEIGHT: 21'

TABLE 2

INSTALLER MODEL	RETAIL MODEL	DESCRIPTION
4300, H300	HDG, 66, 6200	27 GA. MIN. EXTERIOR SKIN; SHORT RAISED PANEL
4400, H400	N/A	24 GA. MIN. EXTERIOR SKIN; SHORT RAISED PANEL
4401, H401	N/A	24 GA. MIN. EXTERIOR SKIN; FLUSH PANEL
4301, H301	68, 6201	27 GA. MIN. EXTERIOR SKIN; FLUSH PANEL
4310, H310	HDGL, 67, 6203	27 GA. MIN. EXTERIOR SKIN; WIDE RAISED PANEL

SECTION B-B

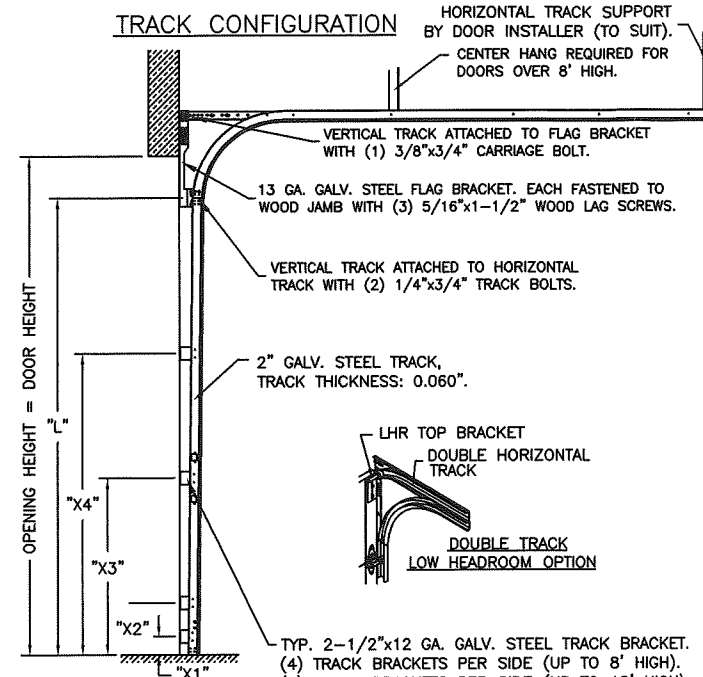
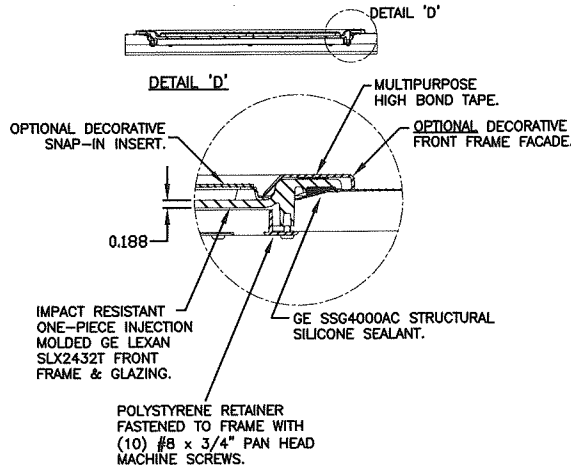

BRACKET PLACEMENTS

DOOR HEIGHT	"L"	"X1"	"X2"	"X3"	"X4"	"X5"	"X6"	"X7"	"X8"
6'-6"	70"	3-1/2"	10"	35"	60"	-	-	-	-
7'-0"	76"	3-1/2"	10"	38"	66"	-	-	-	-
7'-6"	82"	3-1/2"	10"	34"	58"	-	-	-	-
8'-0"	88"	3-1/2"	10"	34"	58"	-	-	-	-
8'-6"	94"	3-1/2"	10"	34"	58"	82"	-	-	-
9'-0"	100"	3-1/2"	10"	34"	58"	82"	-	-	-
9'-6"	106"	3-1/2"	10"	34"	58"	82"	-	-	-
10'-0"	112"	3-1/2"	10"	34"	58"	82"	-	-	-
10'-6"	118"	3-1/2"	10"	34"	58"	82"	106"	-	-
11'-0"	124"	3-1/2"	10"	34"	58"	82"	106"	-	-
11'-6"	130"	3-1/2"	10"	34"	58"	82"	106"	-	-
12'-0"	136"	3-1/2"	10"	34"	58"	82"	106"	-	-
12'-6"	142"	3-1/2"	10"	34"	58"	82"	106"	130"	-
13'-0"	148"	3-1/2"	10"	34"	58"	82"	106"	130"	-
13'-6"	154"	3-1/2"	10"	34"	58"	82"	106"	130"	-
14'-0"	160"	3-1/2"	10"	34"	58"	82"	106"	130"	-
14'-6"	166"	3-1/2"	10"	34"	58"	82"	106"	130"	154"
15'-0"	172"	3-1/2"	10"	34"	58"	82"	106"	130"	154"
15'-6"	178"	3-1/2"	10"	34"	58"	82"	106"	130"	154"
16'-0"	184"	3-1/2"	10"	34"	58"	82"	106"	130"	154"

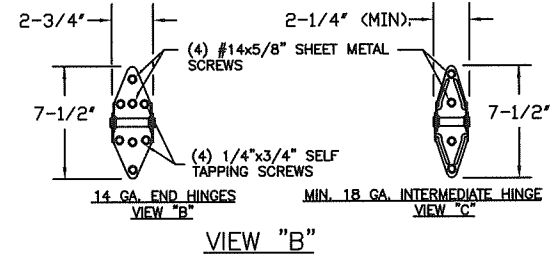
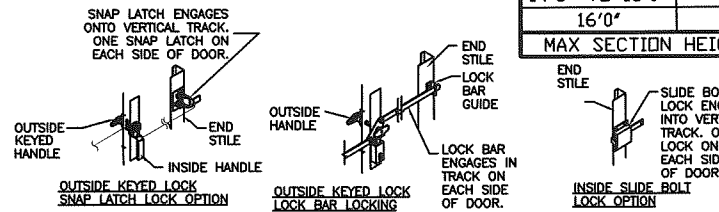

JAMB CONFIGURATION

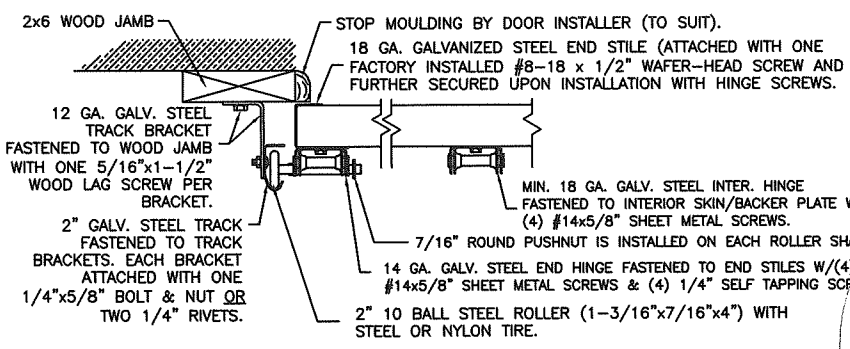

SECTION A-A

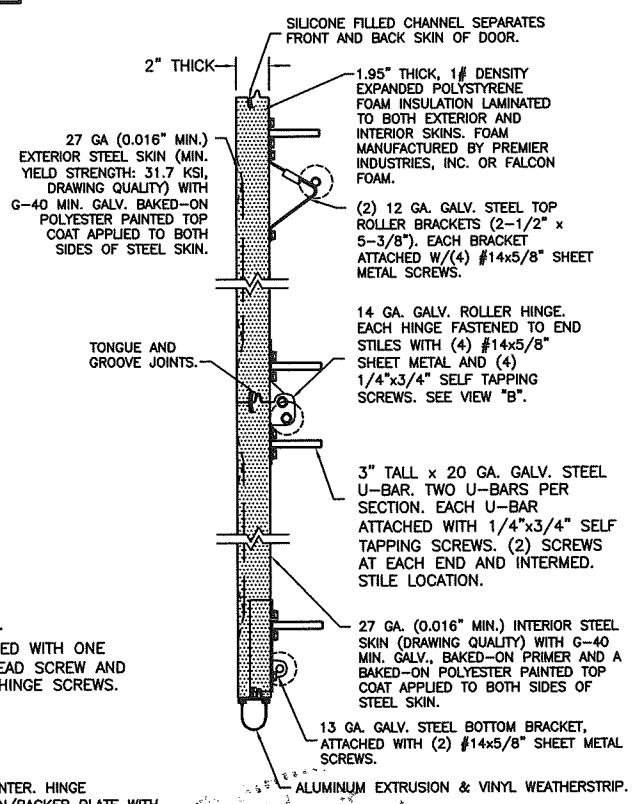

PRODUCT RENEWED
 as complying with the Florida Building Code
 NOA-No. 22-0707.10
 Expiration Date 09/20/2027
 By *[Signature]*
 Miami-Dade Product Control

JAMB TO SUPPORTING STRUCTURE ATTACHMENT

- NOTES:
- ALL THE LOAD FROM THE DOOR IS TRANSFERRED TO THE TRACK AND THEN FROM THE TRACK TO THE 2x6 VERTICAL SYP (GRADE #2 OR BETTER) JAMBS. NO LOAD FROM THE DOOR IS TRANSFERRED TO THE HORIZONTAL (TOP) JAMB.
 - ALL JAMB FASTENERS MAY BE (BUT ARE NOT REQUIRED TO BE) COUNTERSUNK TO PROVIDE A FLUSH MOUNTING SURFACE.
 - A 1/3 STRESS INCREASE FOR WIND LOAD WAS NOT USED IN THE CALCULATION OF ALLOWABLE LOADS FOR ANCHORS AND FASTENERS FOR STEEL, CONCRETE AND MASONRY.

WOOD FRAME BUILDINGS
 STUD WALLS OF DOOR OPENING SHALL BE FRAMED SOLID BY NOT LESS THAN (3) 2x6 PRESSURE TREATED SYP (GRADE #2 OR BETTER) WOOD STUDS OF A STRESS GRADE NOT LESS THAN 1200 PSI NOMINAL EXTREME FIBER STRESS IN BENDING (F_b). STUD WALLS TO BE CONTINUOUS FROM FOOTING TO TIE BEAMS.

BLOCK WALL OR CONCRETE
 2x6 SYP (GRADE #2 OR BETTER) WOOD JAMB SHALL BE ANCHORED TO GROUT REINFORCED BLOCK WALL OR CONCRETE COLUMN. BLOCK WALL CELLS SHALL BE FILLED WITH CONCRETE AND REINFORCED WITH REINFORCING BARS EXTENDING INTO THE FOOTING AND INTO THE BEAMS. ALL BARS SHALL BE CONTINUOUS FROM THE TIE BEAMS TO FOOTING PER BLOCK WALL OR CONCRETE COLUMN. BLOCK WALLS AND CONCRETE COLUMNS TO BE DESIGNED BY THE BUILDING ENGINEER OR ARCHITECT OF RECORD.

2x6 JAMB TO SUPPORTING STRUCTURE ATTACHMENT
 (NOT TO BE USED FOR ATTACHMENT OF TRACK BRACKETS)

BUILDING TYPE	ANCHOR/FASTENER	MAXIMUM # ON CENTER DISTANCE BETWEEN FASTENERS	STEEL WASHERS REQUIRED?
C-90 BLOCK (HOLLOW OR GROUTED)	1/4" x 3" (1-1/4" EMBED) ITW TAPCON CONCRETE ANCHOR (2-1/2" MIN. EDGE DISTANCE)	10-1/2"	1" O.D.
3,000 PSI MIN. CONCRETE	1/4" x 4" (1-3/4" EMBED) ITW TAPCON CONCRETE ANCHOR (2-1/2" MIN. EDGE DISTANCE)	24"	1" O.D.
3,000 PSI MIN. CONCRETE	1/2" x 4" (2-1/4" EMBED) SIMPSON STRONG-TIE WEDGE-ALL WEDGE ANCHOR (2" MIN. EDGE DISTANCE)	21-1/2"	INCLUDED
WOOD FRAME	1/2" x 4" (1-5/8" EMBED) LAG SCREW (ASTM A307, GRADE A) (2-1/2" MIN. EDGE DISTANCE)	24"	1" O.D.
2,000 PSI MIN. CONCRETE	1/2" x 4" (2-1/2" EMBED) WEJ-IT SLEEVE ANCHOR (2-1/2" MIN. EDGE DISTANCE)	24"	INCLUDED

* - FIRST ANCHOR/SCREW STARTING FROM BOTTOM AT NO MORE THAN HALF OF MAXIMUM ON CENTER DISTANCE. HIGHEST ANCHOR/SCREW INSTALLED AT LEAST AS HIGH AS THE DOOR OPENING HEIGHT.

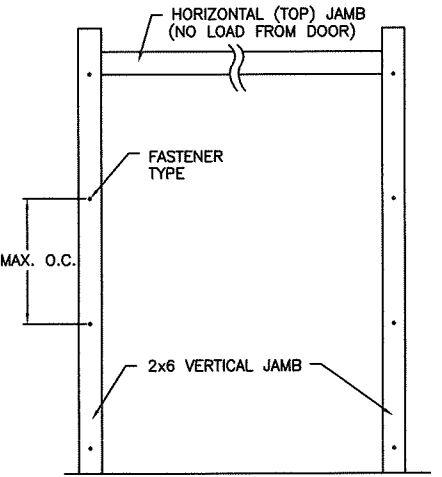

THIS PRODUCT CONFORMS TO THE REQUIREMENTS OF 6TH AND 7TH EDITION OF THE FLORIDA BUILDING CODE
 DESIGN LOADS: +48.0 PSF & -60.0 PSF.

DESIGN ENGINEER:
 MARK WESTERFIELD, P.E.
 FLORIDA P.E. No. 48495

DESIGN ENGINEER:
 SCOTT HAMILTON, P.E.
 FLORIDA P.E. No. 63286

Clopay CORPORATION
 8585 DUKE BLVD.
 MASON, OH 45040
 (513) 770-4800

SCALE: N/A	CLASSIFICATION: APPROVED INSTALLATION DRAWING	MAXIMUM DOOR SIZE: 9'0" W x 16'0" H
DATE: 11/19/96	DESCRIPTION: HDG/HDGL, 66/68, 4300/01, 4310/67/HDGL, 4400/01, H MODELS	
DRAWN BY: MWW	CHECKED BY: B	DRAWING NUMBER: 101703