



DEPARTMENT OF REGULATORY AND ECONOMIC RESOURCES (RER)  
BOARD AND CODE ADMINISTRATION DIVISION

MIAMI-DADE COUNTY  
PRODUCT CONTROL SECTION  
11805 SW 26 Street, Room 208  
Miami, Florida 33175-2474  
T (786) 315-2590 F (786) 315-2599

[www.miamidade.gov/economy](http://www.miamidade.gov/economy)

**NOTICE OF ACCEPTANCE (NOA)**

**Kirby Building Systems  
305 Industrial Parkway  
Waterloo, IN 46793**

**SCOPE:**

This NOA is being issued under the applicable rules and regulations governing the use of construction materials. The documentation submitted has been reviewed and accepted by Miami-Dade County RER- Product Control Section to be used in Miami Dade County and other areas where allowed by the Authority Having Jurisdiction (AHJ).

This NOA shall not be valid after the expiration date stated below. The Miami-Dade County Product Control Section (In Miami Dade County) and/or the AHJ (in areas other than Miami Dade County) reserve the right to have this product or material tested for quality assurance purposes. If this product or material fails to perform in the accepted manner, the manufacturer will incur the expense of such testing and the AHJ may immediately revoke, modify, or suspend the use of such product or material within their jurisdiction. RER reserves the right to revoke this acceptance if it is determined by Miami-Dade County Product Control Section that this product or material fails to meet the requirements of the applicable building code.

This product is approved as described herein and has been designed to comply with the High Velocity Hurricane Zone of the Florida Building Code.

**DESCRIPTION: 0.024" (min.) Structural Loc-Seam 360 Steel Roof Panel**

**APPROVAL DOCUMENT:** Drawing No. MD-LOC, titled "Loc Seam 360 roof Panels", sheets 1 through 6 of 6, prepared by John W. Stark, P.E., dated September 07, 2022, signed and sealed by John W. Stark, P.E. on March 22, 2024, bearing the Miami-Dade County Product Control Revision stamp with the Notice of Acceptance number and the expiration date by the Miami-Dade County Product Control Section.

**MISSILE IMPACT RATING: Large and Small Missile Impact Resistant**

**LABELING:** Each panel shall bear a permanent label with the manufacturer's name or logo, Eufaula, AL or Swansea, SC and the following statement: "Miami-Dade County Product Control Approved", unless otherwise noted herein.

**RENEWAL** of this NOA shall be considered after a renewal application has been filed and there has been no change in the applicable building code negatively affecting the performance of this product.

**TERMINATION** of this NOA will occur after the expiration date or if there has been a revision or change in the materials, use, and/or manufacture of the product or process. Misuse of this NOA as an endorsement of any product, for sales, advertising or any other purposes shall automatically terminate this NOA. Failure to comply with any section of this NOA shall be cause for termination and removal of NOA.

**ADVERTISEMENT:** The NOA number preceded by the words Miami-Dade County, Florida, and followed by the expiration date may be displayed in advertising literature. If any portion of the NOA is displayed, then it shall be done in its entirety.

**INSPECTION:** A copy of this entire NOA shall be provided to the user by the manufacturer or its distributors and shall be available for inspection at the job site at the request of the Building Official.

This NOA revises NOA # 22-1019.01 and consists of this page 1, evidence submitted pages E-1 and E-2 as well as approval document mentioned above.

The submitted documentation was reviewed by **Helmy A. Makar, P.E., M.S.**



*Helmy A. Makar*  
04/04/24

NOA No. 23-0714.05  
Expiration Date: 04/13/2028  
Approval Date: 04/04/2024

**Kirby Building Systems**

**NOTICE OF ACCEPTANCE: EVIDENCE SUBMITTED**

**1. EVIDENCE SUBMITTED UNDER PREVIOUS NOA #22-1019.01**

**A. DRAWINGS**

1. *Drawing No. MD-LOC, titled "Loc Seam 360 roof Panels", sheets 1 through 6 of 6, prepared by Bala Sockalingam, P.E., last revision dated September 07, 2022, signed and sealed by Bala Sockalingam, P.E. on March 01, 2023.*

**B. TESTS**

1. *Test report on Accelerated Weathering Testing of Coating 2000 hours per ASTM G152, prepared by PPG Industrial Coil Coatings.*
2. *Test report on Salt Spray Testing of Coating 1000 hours per ASTM B117-95, prepared by PPG Industrial Coil Coatings.*
3. *Test report for Uniform Static Air Pressure on 24 ga. Loc-Seam 360 Roof Panel, prepared by Force Engineering & Testing, per TAS 125-03 per ASTM E 1592-05, Report No. 534-0047T-22A-D, dated September 12, 2022, signed and sealed by Johnathan Green, P.E.*
4. *Susceptibility to leakage test in accordance with FM 4471, Appendix G on 24 ga. Loc-Seam 360 Roof Panel, prepared by FET, Report No. T272-22, dated August 09, 2022, signed and sealed by Daniel G. Farabaugh, P.E.*
5. *Wind Driven Rain Test in accordance with Miami-Dade County Protocol TAS 100-95 on 24 ga. Loc-Seam 360 Roof Panel, prepared by FET, Report No. T274-22, dated August 15, 2022, signed and sealed by Daniel G. Farabaugh, P.E.*
6. *Impact test per TAS 201-94, test report #534-0047T-22E, dated September 12, 2022, signed and sealed by Johnathan Green, P.E.*

**C. CALCULATIONS**

1. *Calculations titled "Loc-Seam 360, 24 ga. Roof Panel Calculations", dated March 01, 2023, pages 1 through 3 of 3, prepared by Bala Sockalingam, P.E., signed and sealed by Bala Sockalingam, P.E.*

**D. QUALITY ASSURANCE**

1. *By Miami Dade County Department of Regulatory and Economic Resources*

**E. MATERIAL CERTIFICATIONS**

1. *None.*

**F. STATEMENTS**

1. *Florida Building Code, 2020 Edition, compliance letter, dated September 21, 2022, prepared by Bala Sockalingam, P.E., signed and sealed by Bala Sockalingam P.E. on September 21, 2022*

  
\_\_\_\_\_  
Helmy A. Makar, P.E., M.S.  
Product Control Section Supervisor  
NOA No. 23-0714.05  
Expiration Date: 04/13/2028  
Approval Date: 04/04/2024



**Kirby Building Systems**

**NOTICE OF ACCEPTANCE: EVIDENCE SUBMITTED**

**2. EVIDENCE SUBMITTED UNDER PREVIOUS NOA #23-0821.12**

**A. DRAWINGS**

1. *Drawing No. MD-LOC, titled "Loc Seam 360 roof Panels", sheets 1 through 6 of 6, prepared by Bala Sockalingam, P.E., last revision #1 dated July 21, 2023, signed and sealed by Bala Sockalingam, P.E. on July 21, 2023.*

**B. TESTS**

1. *None.*

**C. CALCULATIONS**

1. *None.*

**D. QUALITY ASSURANCE**

1. *By Miami Dade County Department of Regulatory and Economic Resources*

**E. MATERIAL CERTIFICATIONS**

1. *None.*

**F. STATEMENTS**

1. *Florida Building Code, 2020 Edition and 2023 Edition, compliance letter, dated July 21, 2023, prepared by Bala Sockalingam, P.E., signed and sealed by Bala Sockalingam P.E. on July 21, 2023.*

**3. NEW EVIDENCE SUBMITTED**

**A. DRAWINGS**

1. *Drawing No. MD-LOC, titled "Loc Seam 360 roof Panels", sheets 1 through 6 of 6, prepared by John W. Stark, P.E., dated September 07, 2022, signed and sealed by John W. Stark, P.E. on March 22, 2024.*

**B. TESTS**

1. *PLA from NOA #23-0821.12*

**C. CALCULATIONS**

1. *PLA from NOA #23-0821.12*

**D. QUALITY ASSURANCE**

1. *By Miami Dade County Department of Regulatory and Economic Resources*

**E. MATERIAL CERTIFICATIONS**

1. *PLA from NOA #23-0821.12*

**F. STATEMENTS**

1. *FBC, 2023 Edition, compliance drawings, prepared by John W. Stark, P.E., dated 09/07/2022, signed and sealed by John W. Stark, P.E. on 03/22/2024.*

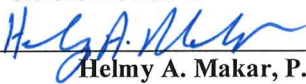
  
\_\_\_\_\_  
Helmy A. Makar, P.E., M.S.  
Product Control Section Supervisor  
NOA No. 23-0714.05  
Expiration Date: 04/13/2028  
Approval Date: 04/04/2024

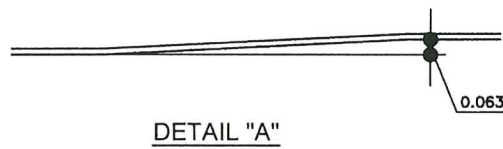

NOTE:  
RADIi ARE R.093  
UNO

TOLERANCE STANDARDS  
 \* Accumulation ± 0.060  
 Depth ± 0.031  
 Radii ± 0.030  
 Angles ± 2°  
 Camber 0.125" in 10'  
 Ski 0.125" in 10'  
 Dive 0.125" in 10'  
 \* Net Variation for Combined Dimensions

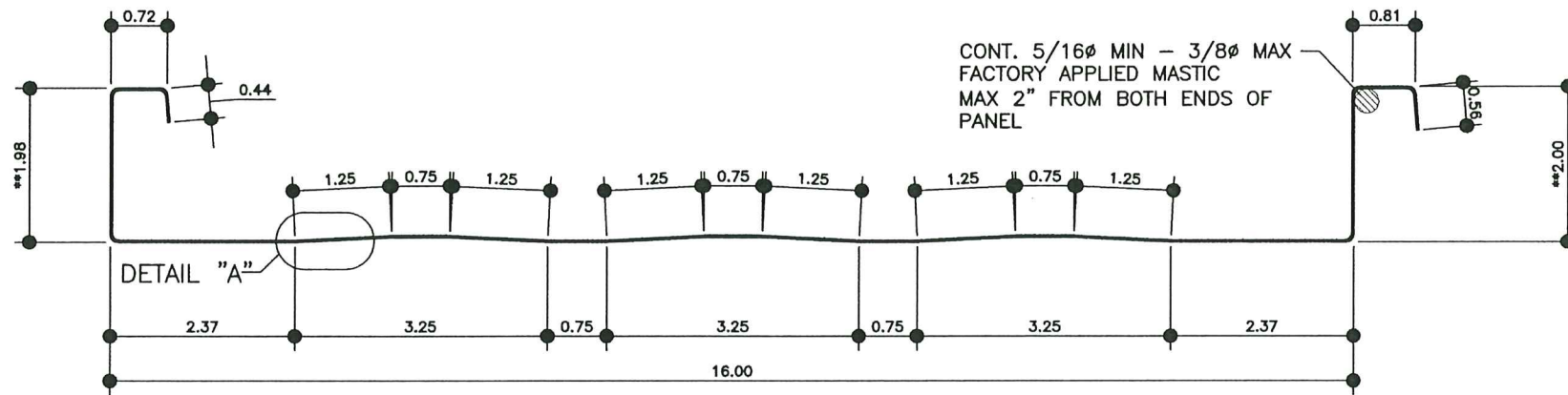

CONT. 5/16Ø MIN - 3/8Ø MAX  
 FACTORY APPLIED MASTIC  
 MAX 2" FROM BOTH ENDS OF  
 PANEL

LOC SEAM 360 PROFILE

GENERAL NOTES:

- MATERIAL: 24 GA (0.024" MIN), AZ55 WITH MIN. NOM Fy = 50 KSI (58 KSI TESTED)  
 1a. ALT MATERIAL: 22 GA, AZ55 WITH MIN. Fy = 50 KSI
- COIL WIDTH: 22.00"
- MATERIAL IS ASTM A-792  
 AZ55 FOR GALVALUME  
 AZ50 FOR PAINTED
- MASTIC SHALL BEGIN AND END A MAXIMUM OF 2" FROM PANEL ENDS ON UN-SWAGED PANELS. 2" MAXIMUM FROM END OF SWAGE, ON SWAGED PANELS.
- MINIMUM ALLOWABLE ROOF SLOPE 1/4:12

DESIGN NOTES:

- THIS STRUCTURAL ROOF PANEL SYSTEM HAS BEEN DESIGNED IN ACCORDANCE WITH 2023 FLORIDA BUILDING CODE (F.B.C.). THE DESIGN PRESSURES AS DETERMINED FROM SECTION 1620 AND ASCE 7-22 MUST BE MULTIPLIED BY 0.6.
- THIS ROOF PANEL IS DESIGNED FOR SPANS UP TO 5'-0" MAXIMUM
- DEFLECTION SHALL BE LIMITED TO L/180
- THIS ROOF PANEL IS APPROVED FOR GRAVITY (POSITIVE) PRESSURE OF 70.25 PSF.
- THIS ROOF PANEL IS APPROVED FOR UPLIFT (NEGATIVE) PRESSURE AS SHOWN IN THE TABLE BELOW. FOR PANEL SPANS BETWEEN 1'-0" AND 5'-0" THE MAXIMUM UPLIFT PRESSURE CAN BE DETERMINED BY INTERPOLATION.

MAXIMUM PANEL SPAN	MAXIMUM UPLIFT PRESSURE (PSF)
5' 0"	44.2
4' 6"	49.1
4' 0"	55.3
3' 6"	63.2
3' 0"	73.7
2' 6"	88.4
2' 0"	110.5
1' 6"	136.7
1' 0"	150.9

NO.	REVISION	MADE	DATE

LOC SEAM 360 ROOF PANEL

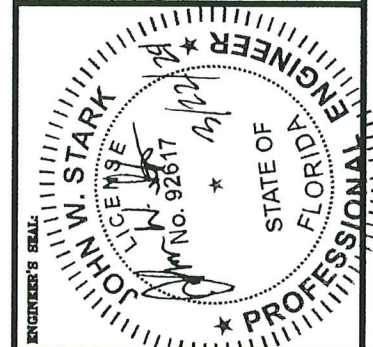

ENGINEER'S NAME: JOHN W. STARK, P.E.	ENGINEER'S STATE REGISTRATION NUMBER: 92617
DATE: 09-01-22	DATE: 09-07-22
SCALE: NOT TO SCALE	DRAWN BY: ESB CHECKED BY: SLF
124 KIRBY DRIVE PORTLAND, TN 37148 PHONE: (615) 325-4165 <b>KIRBY BUILDING SYSTEMS</b> FLUOR	
DRAWING #: MD-LOC SEAM 360 24 GA Pg. 1 of 6	
REVISION NUMBER 0	

For Dade County Office Use Only

PRODUCT REVISED  
 as complying with the Florida  
 Building Code  
 Acceptance No. 23-0714.05  
 Expiration Date 04/13/2028  
 By: *[Signature]*  
 Miami Dade Product Control



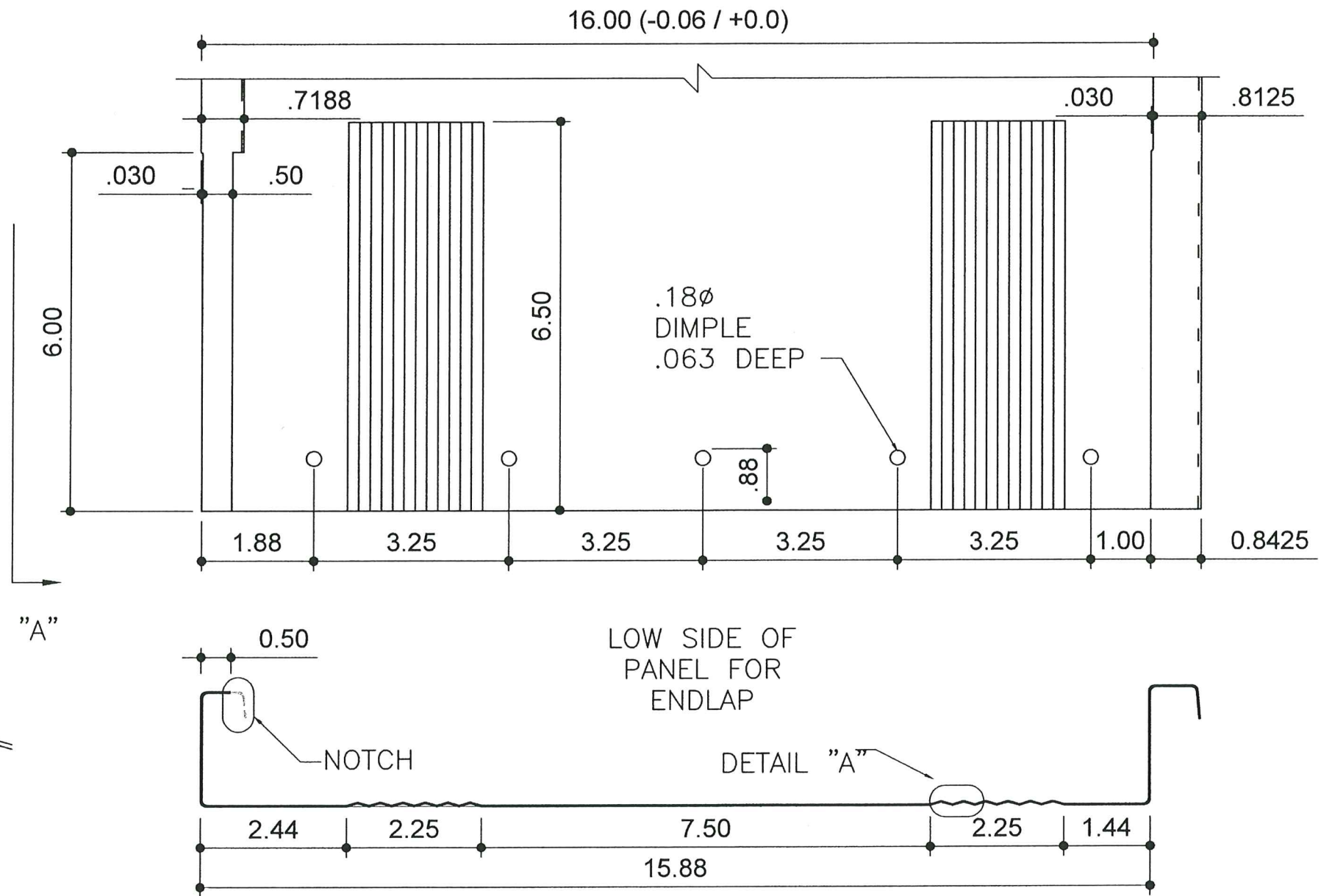
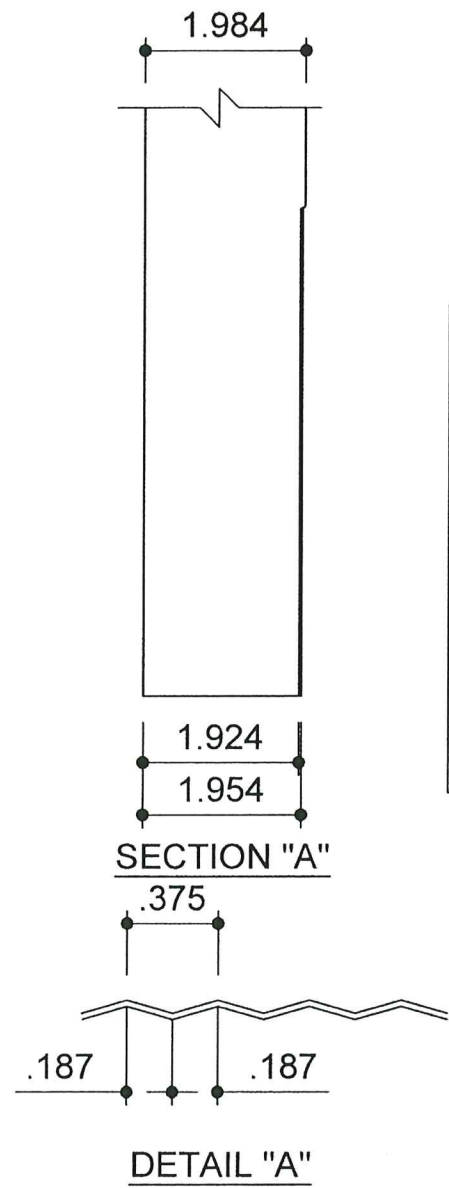

NOTES:

- 1) MATERIAL IS ASTM A-792  
AZ55 FOR GALVALUME  
AZ50 FOR PAINTED
- 2) SWAGE IS THE PROCESS OF CRIMPING PANEL TO NARROW IT ALLOWING IT TO NEST INSIDE ANOTHER PANEL
- 3) SWAGE & DIMPLES ARE ON THE LOW SIDE OF THE UP-SLOPE PANEL ONLY.
- 4) PANEL COLORS: ALL STANDARD PVDF COLORS & GM.

NO.	REVISION	MADE	CHKD.	DATE

LOC SEAM 360 ROOF PANEL



ENGINEER'S NAME: JOHN W. STARK, P.E.	ENGINEER'S STATE REGISTRATION NUMBER: 92617
DATE: 09-01-22	DATE: 09-07-22
SCALE: NOT TO SCALE	SCALE: NOT TO SCALE
DRAWN BY: EGB	CHECKED BY: ELP
124 KIRBY DRIVE PORTLAND, TN 37146 PHONE: (615) 325-4165	
DRAWING #: MD-LOC SEAM 360 24 GA. Pg. 2 of 6	

For Dade County Office Use Only

PRODUCT REVISED  
as complying with the Florida  
Building Code  
Acceptance No. 23-0714.05  
Expiration Date 04/13/2028

By: *[Signature]*  
Miami Dade Product Control

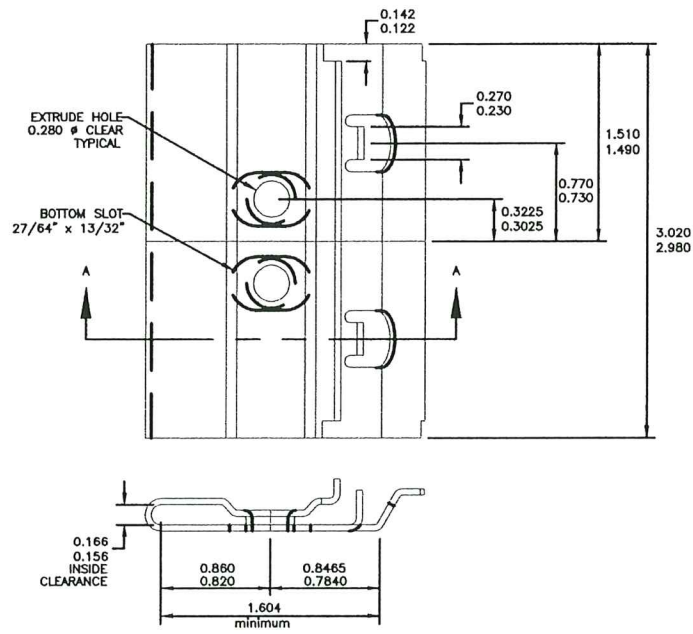

PART "A"

PART A MATERIAL = G90 GALVANIZED, GRADE 50  
50,000 PSI ASTM A653  
THICKNESS = 0.048" ± 0.002"

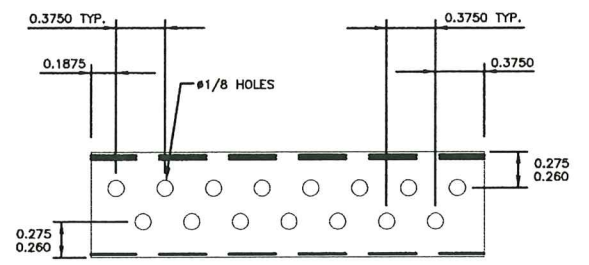

PART "B" PERFORATIONS

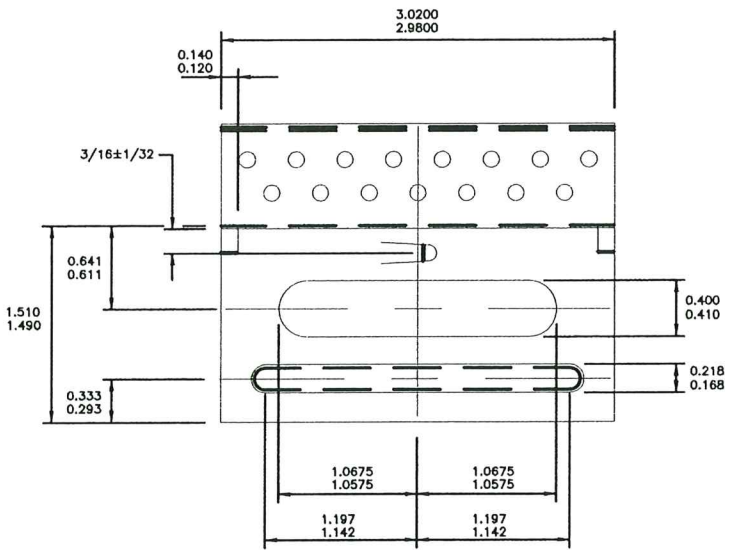

PART "B"

PART B MATERIAL = G90 GALVANIZED, GRADE 50  
50,000 PSI ASTM A653  
THICKNESS = 0.026" ± 0.002"

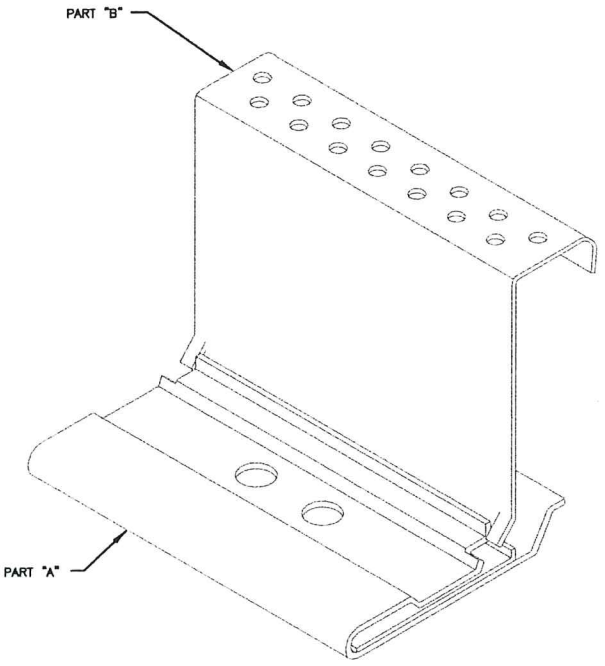

CLIP ASSEMBLY

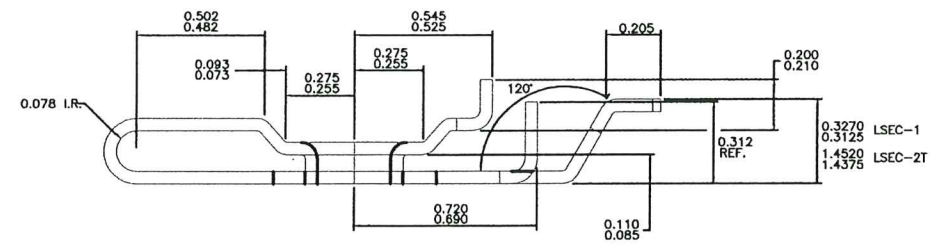

EXTRUDED HOLE TO REST ON PURLIN WHEN INSTALLED. EXTRUSION WILL BE SUFFICIENT TO HOLD MATERIAL APART TO AVOID BINDING WHEN CLIPS ARE SCREWED DOWN.

SECTION "A-A"

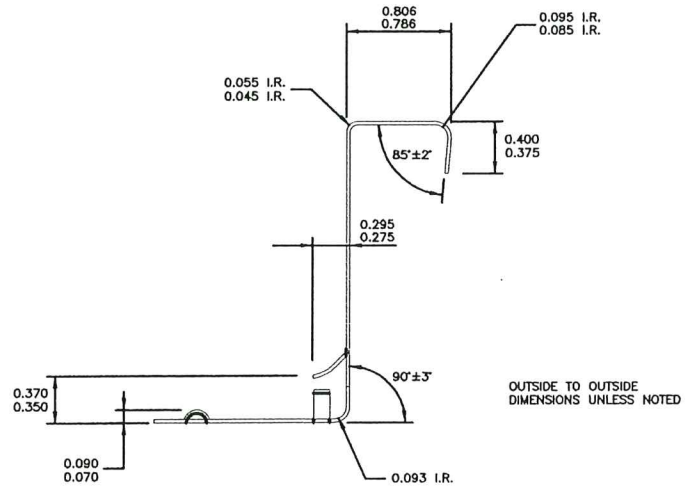
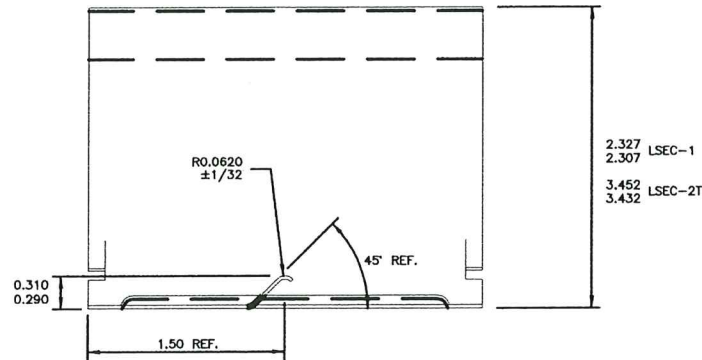

NOTES:  
ALL DIMENSIONS ± .020 UNLESS NOTED  
WGT. = 0.238#

NO.	REVISION	MADE	CTD.	DATE

LOC SEAM 360 ROOF PANEL



ENGINEER'S NAME: JOHN W. STARK, P.E.	ENGINEER'S STATE REGISTRATION NUMBER: 92617
DATE 09-01-22	DRAWN BY: ECB
09-07-22	CHECKED BY: SLF
124 KIRBY DRIVE PORTLAND, TN 37146 PHONE: (615) 325-4196 KIRBY BUILDING SYSTEMS A NUCOR COMPANY	
DRAWING #: MD-LOC SEAM 360 24 GA. Pg. 3 of 6	
REVISION NUMBER 0	

For Dade County Office Use Only

PRODUCT REVISED  
as complying with the Florida  
Building Code  
Acceptance No. 23-0714.05  
Expiration Date 04/13/2024  
By *[Signature]*  
Miami Dade Product Control



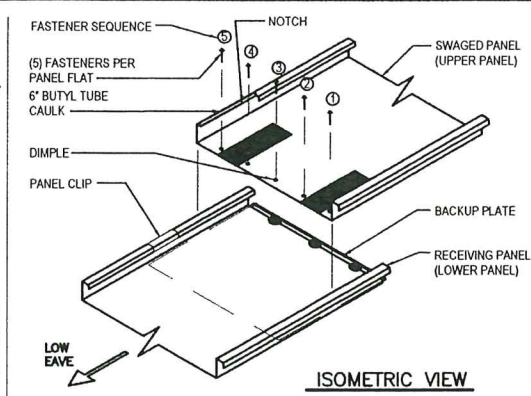
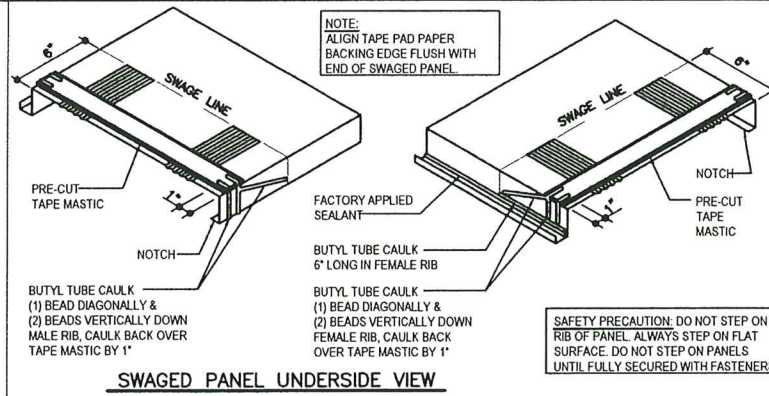

**NOTE:** ALL AREAS ON ALUMINUM COATED PANELS THAT REQUIRE MASTIC SHOULD BE WIPED CLEAN WITH A MILD ALL PURPOSE DETERGENT CLEANER BEFORE MASTIC APPLICATION.

- 1) WHEN ENDLAPS ARE REQUIRED THE LOWER 6 INCHES OF THE UPPER PANEL ARE SWAGED, WHICH ALLOWS FOR A BETTER LAP ON TO THE LOWER RECEIVING PANEL. THIS LAP WILL OCCUR APPROXIMATELY 12 INCHES UPSLOPE FROM A PURLIN OR JOIST RUN.
- 2) PRIOR TO SETTING THE SWAGED PANEL, INSTALL THE BACKUP PLATE ONTO THE LOWER RECEIVING PANEL AS SHOWN.
- 3) NEXT INSTALL A PIECE OF PRE-CUT TAPE MASTIC ACROSS THE WIDTH OF THE UNDERSIDE OF THE SWAGED PANEL BEGINNING AND ENDING AT THE VERTICAL SEAMS (LEGS). ALSO APPLY TUBE CAULK ON THE MALE AND FEMALE RIBS OF THE SWAGED PANEL AS SHOWN IN DETAIL ABOVE.
- 4) NEXT APPLY TUBE CAULK ALONG BOTH PANEL RIBS OF THE LOWER RECEIVING PANEL AS SHOWN IN THE ENDLAP CAULKING DETAIL.
- 5) INSTALL THE UPPER SWAGED PANEL. BOW PANEL IN THE MIDDLE DURING INSTALLATION TO AVOID SWIMPING CAULK FROM THE VERTICAL LEGS OF THE PANEL AT THE ENDLAP.
- 6) NEXT SECURE THE LAP WITH (5) ROOF FASTENERS IN THE PRE-DIMPLED LOCATIONS.
- 7) HAND SEAM PANEL RIBS TOGETHER AT ENDLAP PRIOR TO MECHANICALLY SEAMING.

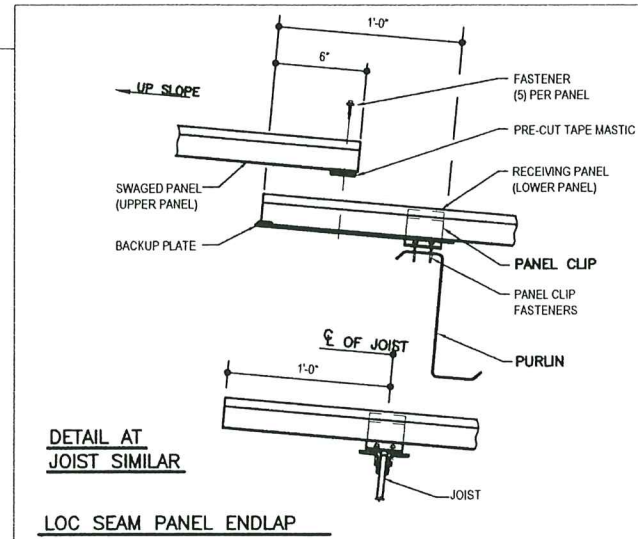
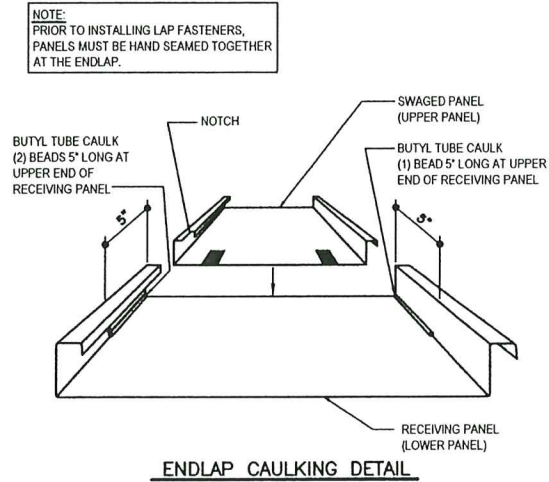

NO.	REVISION	MADE	BY	DATE

LOC SEAM 360 ROOF PANEL



ENGINEER'S NAME: JOHN W. STARK, P.E.  
ENGINEER'S STATE REGISTRATION NUMBER: 92617

124 KIRBY DRIVE  
PORTLAND, TN 37148  
PHONE: (616) 326-4165

SCALE: NOT TO SCALE  
DRAWN BY: EGB  
CHECKED BY: BLP

DATE: 09-01-22  
09-07-22

KIRBY BUILDING SYSTEMS  
FLUORCOR

DRAWING #: MD-LOC SEAM 360 24 GA. Pg. 4 of 6  
REVISION NUMBER: 0

**For Dade County Office Use Only**

PRODUCT REVISED as complying with the Florida Building Code  
Acceptance No. 23-0714.05  
Expiration Date 04/13/2028  
By *Healy A. Mator*  
Miami Dade Product Control



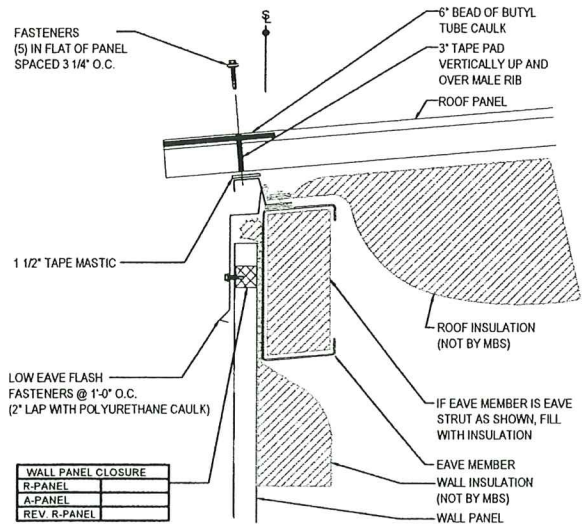

**BASIC EAVE DETAIL**  
 BASIC EAVE DETAIL w/ WALL PANELS  
 SEE WALL SHEETING ERECTION NOTES FOR WALL PANEL FASTENER LOCATIONS

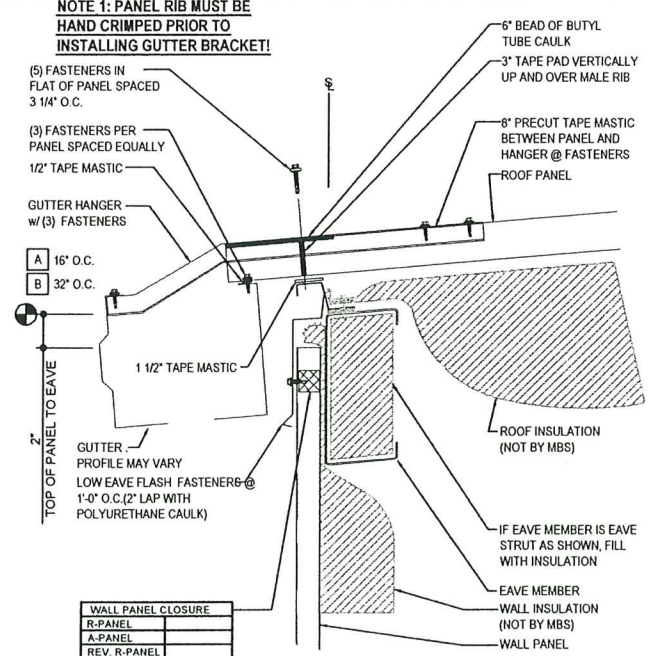

**EAVE GUTTER DETAIL**  
 EAVE GUTTER DETAIL w/ WALL PANELS  
 SEE WALL SHEETING ERECTION NOTES FOR WALL PANEL FASTENER LOCATIONS

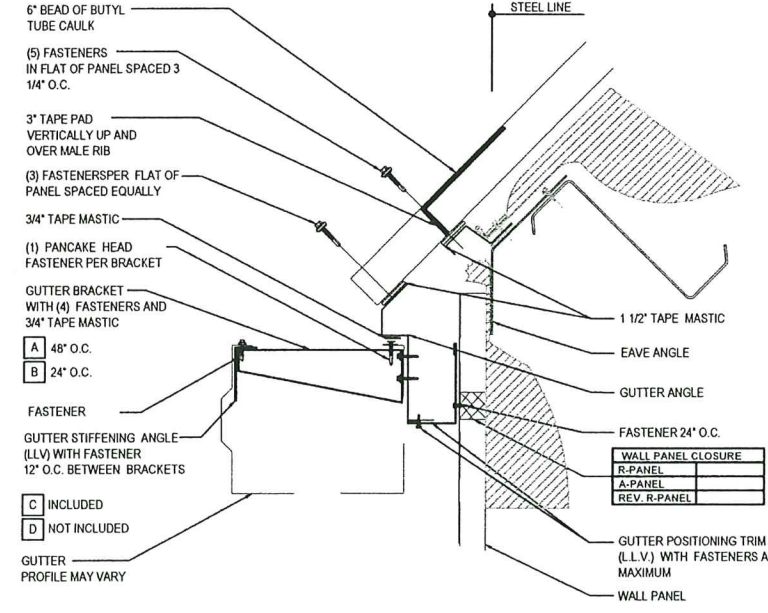

**HORIZONTAL GUTTER DETAIL**  
 HORIZONTAL GUTTER DETAIL w/ WALL PANELS  
 SEE WALL SHEETING ERECTION NOTES FOR WALL PANEL FASTENER LOCATIONS

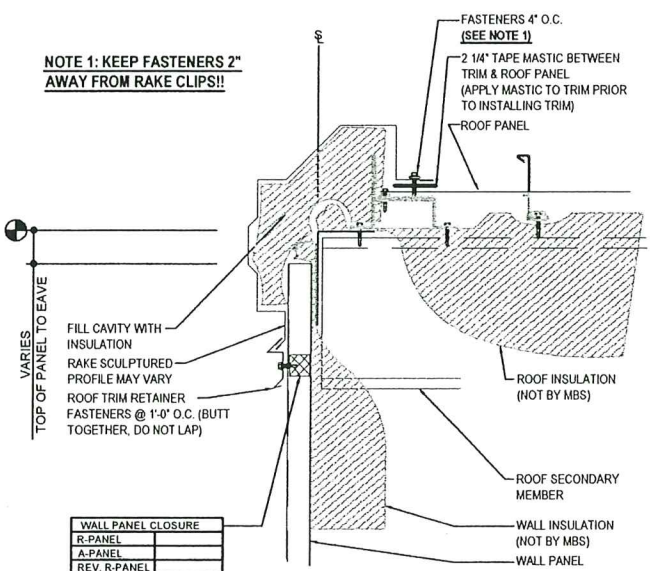

**RAKE SCULPTURED DETAIL**  
 RAKE SCULPTURED DETAIL w/ WALL PANELS  
 SEE WALL SHEETING ERECTION NOTES FOR WALL PANEL FASTENER LOCATIONS

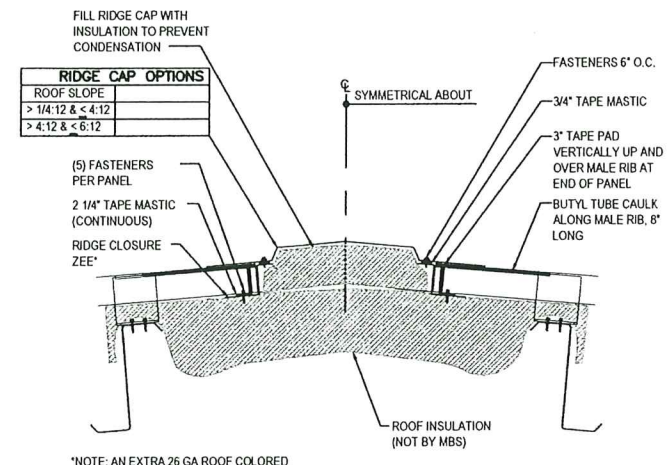

**RIDGE TRIM DETAIL**  
 RIDGE TRIM DETAIL

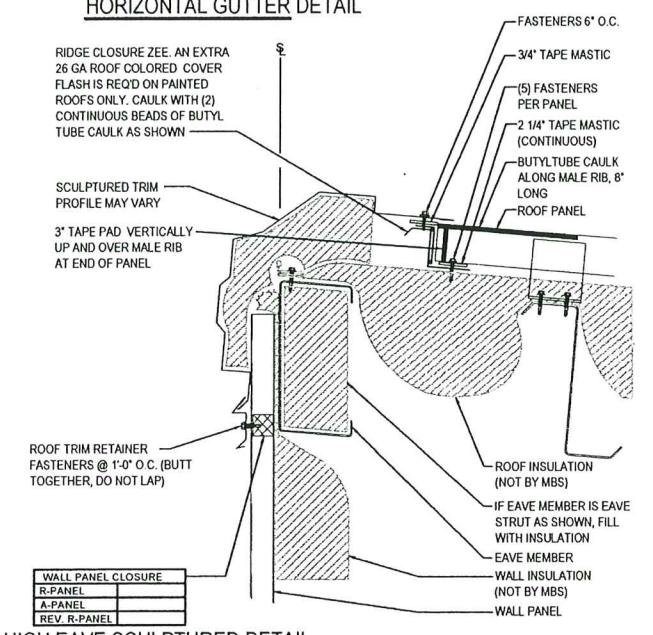

**HIGH EAVE SCULPTURED DETAIL**  
 HIGH EAVE SCULPTURED DETAIL w/ WALL PANELS  
 SEE WALL SHEETING ERECTION NOTES FOR WALL PANEL FASTENER LOCATIONS

NO.	REVISION	MADE (C/D)	DATE



ENGINEER'S NAME:	JOHN W. STARK, P.E.
ENGINEER'S STATE REGISTRATION NUMBER:	92617
DATE:	09-01-22
SCALE:	NOT TO SCALE
DRAWN BY:	ECB
CHECKED BY:	ELP
ENGINEER'S ADDRESS:	124 KIRBY DRIVE PORTLAND, TN 37148 PHONE: (615) 326-4166
ENGINEER'S FIRM:	KIRBY BUILDING SYSTEMS, INCORPORATED
DRAWING #:	MD-LOC SEAM 360 24 GA. Pg. 5 of 6
REVISION NUMBER:	0

For Dade County Office Use Only

PRODUCT REVISED  
 as complying with the Florida  
 Building Code  
 Acceptance No. 23-0714.05  
 Expiration Date 04/13/2028  
 By *Holly A. Miller*  
 Miami Dade Product Control

LOC SEAM 360 ROOF PANEL



# VALLEY CONDITION ERECTION NOTES

- 1) INSTALL THE EAVE ANGLES AND EAVE PLATES AS SHOWN AT RIGHT. CAULK THE EAVE PLATES AT THE CORNER WITH TUBE CAULK.
- 2) AFTER THE INSTALLATION OF THE EAVE ANGLES AND EAVE PLATES, AND BEFORE THE ROOF PANEL INSTALLATION, START AT THE LOW EAVE AND PLACE THE INSULATION PAN IN THE VALLEY AND FASTEN WITH (1) FASTENER AT EACH PURLIN. FIELD MITER THE INSULATION PAN AT THE EAVE PLATE. LAP THE INSULATION PANS 2" AND FASTEN WITH (4) FASTENERS.
- 3) INSTALL THE INSULATION OVER THE INSULATION PAN. FASTEN WITH SCREWS AND INSULATION WASHERS AS REQUIRED.
- 4) BEFORE ROOF PANEL INSTALLATION, START AT THE LOW EAVE AND PLACE THE HAT CHANNEL SECTIONS ON BOTH SIDES OF THE VALLEY, 1'-8" FROM THE CENTERLINE AS SHOWN. FASTEN TO EACH PURLIN WITH (2) FASTENERS.
- 5) CENTER THE VALLEY PLATE OVER THE HAT SECTIONS. AT THE EAVE & RIDGE, EXTEND THE PLATE TO THE EDGE OF THE ROOF PANEL. FIELD CUTTING AS REQUIRED. FASTEN VALLEY PLATE TO HAT CHANNEL INSIDE PANEL RIB WITH (1) FASTENER AS SHOWN BELOW. LAP THE VALLEY PLATE 2" & FASTEN WITH (2) FASTENERS.
- 6) PLACE THE DIVERTER FLASH OVER THE VALLEY PLATE AND TEMPORARILY FASTEN WITH (1) SCREW AT THE OUTSIDE CORNERS OF THE VALLEY PLATE. (DO NOT USE THE VALLEY AS A WALKWAY OR A WORK PLATFORM).
- 7) INSTALL 2 1/4" TAPE MASTIC ON THE DIVERTER FLASH 7 1/2" FROM THE CENTER OF THE PLATE AS SHOWN. DO NOT REMOVE PAPER BACKING UNTIL READY TO SET PANEL. ALSO APPLY A BEAD OF BUTYL TUBE CAULK FOR THE FLAT OF THE PANEL ALONG THE TAPE MASTIC.
- 8) INSTALL THE ROOF PANELS - CUTTING ENDS AT THE ANGLE REQUIRED. CUT PANELS 7" FROM THE CENTER OF THE VALLEY PLATE. (NOTE: KEEP METAL SHAVINGS OUT OF MASTIC AND PANEL SIDELAP.) REMOVE TEMPORARY DIVERTER FASTENER IF NEEDED.
- 9) BEFORE THE NEXT PANEL IS INSTALLED, APPLY A 3" PIECE OF TAPE MASTIC AND A BEAD OF TUBE CAULK TO THE MALE SIDE OF THE PANEL FROM THE LOW END OF THE PANEL UP 12" TO ENSURE WEATHERTIGHTNESS, AS SHOWN IN THE SEALANT DETAIL.
- 10) FASTEN WITH SCREWS, 3" O.C. OVER THE TAPE MASTIC, (8 1/4" FROM THE CENTER OF THE DIVERTER FLASH TO THE CENTER OF THE FASTENERS). TAKE SPECIAL CARE AT THIS POINT TO MAINTAIN PANEL MODULARITY.

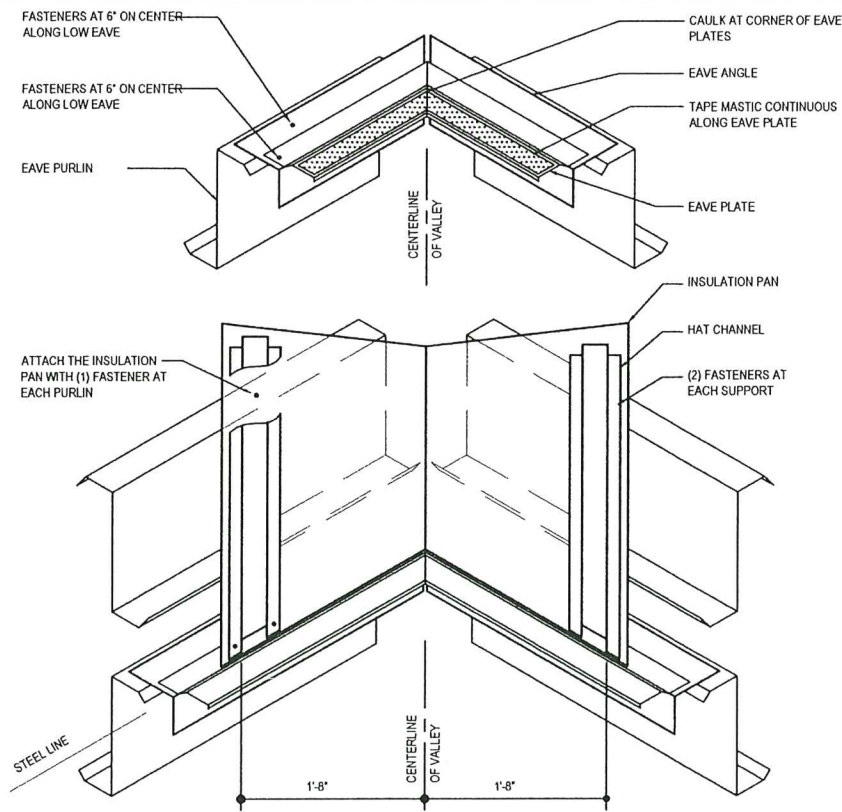

INSULATION PAN, EAVE PLATE, AND HAT CHANNEL DETAIL AT LOW EAVE CORNER

SEE ERECTION NOTES 1, 2, 3 AND 4

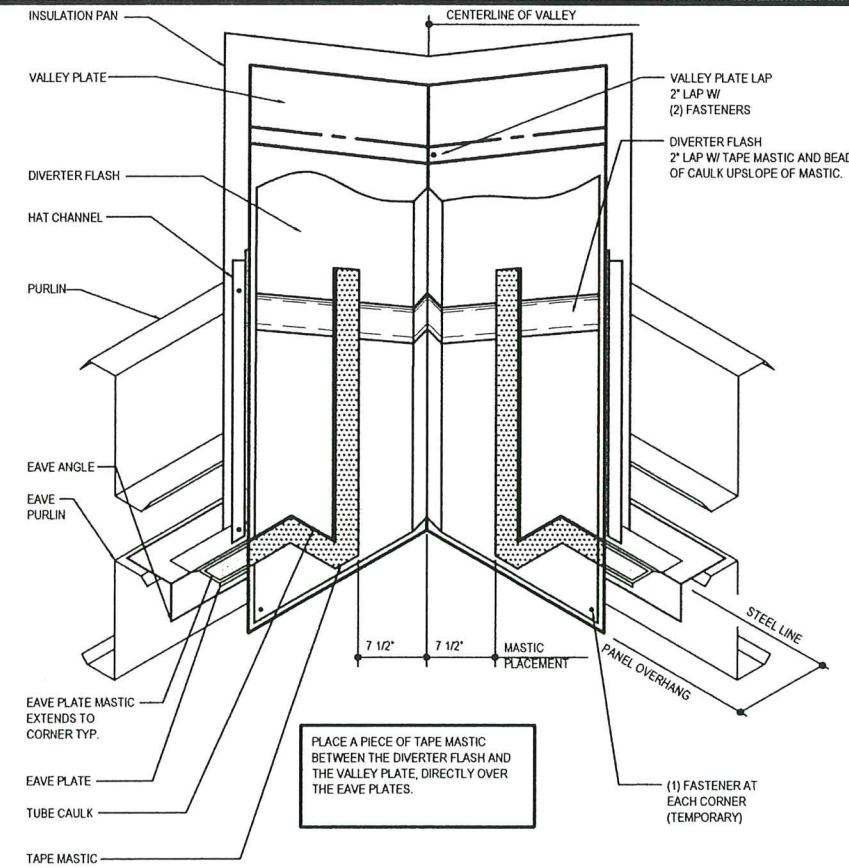

VALLEY PLATE AND DIVERTER FLASH DETAIL AT LOW EAVE CORNER

SEE ERECTION NOTES 5, 6 AND 7

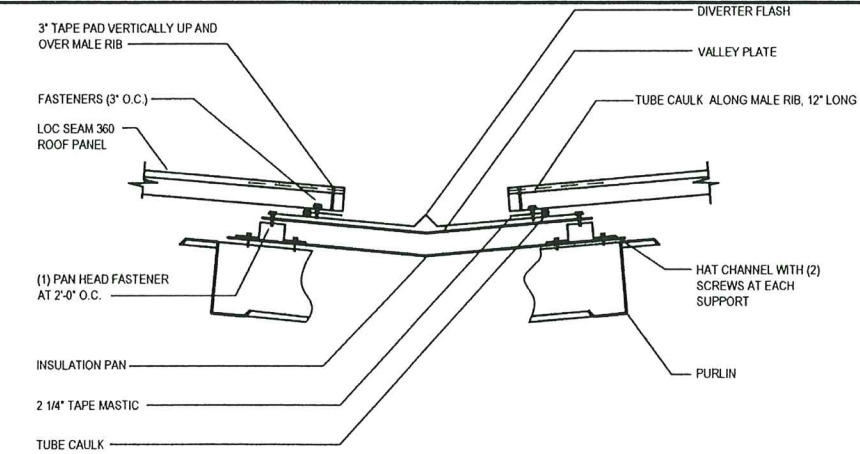

LOC SEAM 360 VALLEY FINAL ASSEMBLY DETAIL

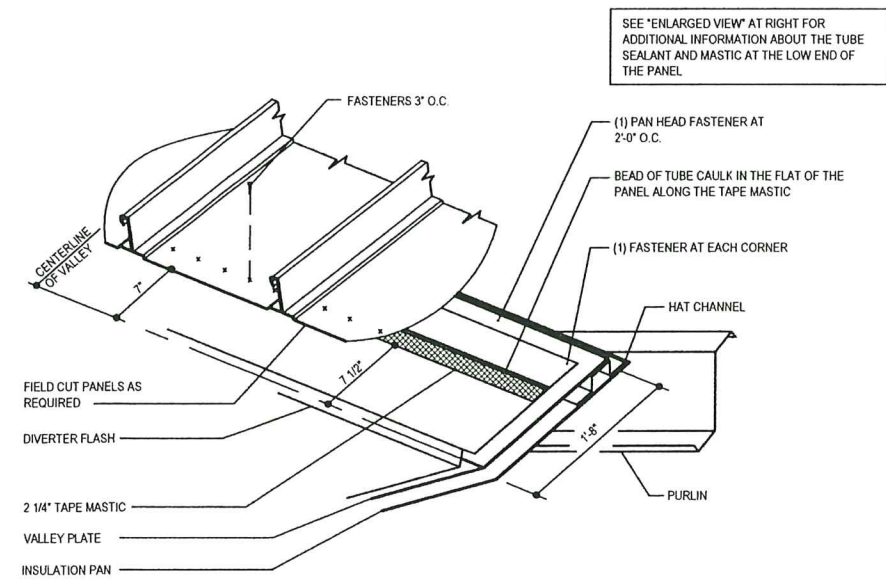

SEALANT DETAIL AT VALLEY

SEE ERECTION NOTES 5, 6, 7 AND 8

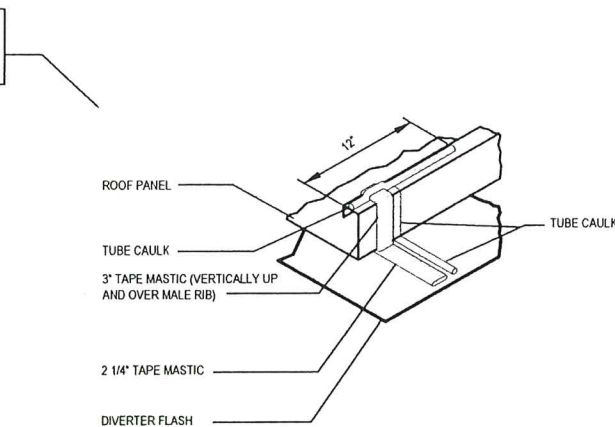

SEALANT DETAIL AT LOW END OF PANELS

SEE ERECTION NOTE 9

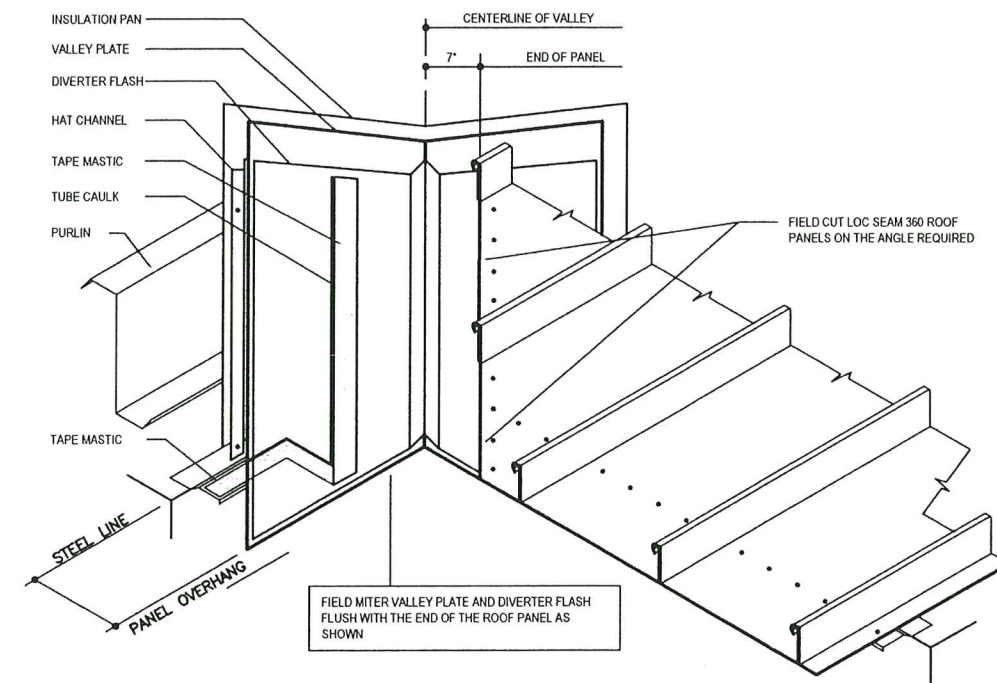

ROOF PANEL CUT DETAIL

NO.	REVISION	DATE	BY

LOC SEAM 360 ROOF PANEL



ENGINEER'S NAME: <b>JOHN W. STARKS, P.E.</b>	ENGINEER'S STATE REGISTRATION NUMBER: <b>92617</b>
SCALE: NOT TO SCALE	DATE: 09-01-82
DRAWN BY: EGB	CHECKED BY: ELP
<b>KIRBY BUILDING SYSTEMS</b> 124 KIRBY DRIVE PORTLAND, TN 37148 PHONE: (615) 325-4165	
DRAWING #: MD-LOC SEAM 360 24 GA. Pg. 6 of 6	
REVISION NUMBER: 0	

For Dade County Office Use Only

PRODUCT REVISED as complying with the Florida Building Code Acceptance No 23-0714.05 Expiration Date 04/13/2026

By *Harley A. Miller*  
Miami Dade Product Control