



DEPARTMENT OF REGULATORY AND ECONOMIC RESOURCES (RER)
BOARD AND CODE ADMINISTRATION DIVISION
NOTICE OF ACCEPTANCE (NOA)

MIAMI-DADE COUNTY
PRODUCT CONTROL SECTION
11805 SW 26 Street, Room 208
Miami, Florida 33175-2474
T (786) 315-2590 F (786) 315-2599
www.miamidade.gov/building

Nailor Industries Inc.
4714 Winfield Road
Houston, TX 77039

SCOPE: This NOA is being issued under the applicable rules and regulations governing the use of construction materials. The documentation submitted has been reviewed and accepted by Miami-Dade County RER-Product Control Section to be used in Miami Dade County and other areas where allowed by the Authority Having Jurisdiction (AHJ).

This NOA shall not be valid after the expiration date stated below. The Miami-Dade County Product Control Section (In Miami Dade County) and/or the AHJ (in areas other than Miami Dade County) reserve the right to have this product or material tested for quality assurance purposes. If this product or material fails to perform in the accepted manner, the manufacturer will incur the expense of such testing and the AHJ may immediately revoke, modify, or suspend the use of such product or material within their jurisdiction. RER reserves the right to revoke this acceptance if it is determined by Miami-Dade County Product Control Section that this product or material fails to meet the requirements of the applicable building code.

This product is approved as described herein and has been designed to comply with the Florida Building Code, including the High Velocity Hurricane Zone.

DESCRIPTION: Model 1606CM Aluminum Louver System

APPROVAL DOCUMENT: Drawing No. 1609HM-NOA, titled "BOM, Notes, Anchors, Elevation, Mull Details, Assembly Details, Head/Sill, Jamb, Profiles", sheets 1 through 7 of 7, prepared by manufacturer, dated 05/27/2021, signed and sealed by Lucas A. Turner, P.E. on 03/07/2024, bearing the Miami-Dade County Product Control Approval stamp with the Notice of Acceptance number and expiration date by the Miami-Dade County Product Control Section.

MISSILE IMPACT RATING: Large and Small Missile Impact Resistant

LABELING: Each unit shall bear a permanent label with the manufacturer's name or logo, Houston, TX, model/series, and following statement: "Miami-Dade County Product Control Approved", unless otherwise noted herein.

LIMITATION: This system is to be installed in a location where the room behind the louver is designed to drain water penetrating into the room, and the room will house water resistant/waterproof equipment, components, or supplies.

RENEWAL of this NOA shall be considered after a renewal application has been filed and there has been no change in the applicable building code negatively affecting the performance of this product.

TERMINATION of this NOA will occur after the expiration date or if there has been a revision or change in the materials, use, and/or manufacture of the product or process. Misuse of this NOA as an endorsement of any product, for sales, advertising or any other purposes shall automatically terminate this NOA. Failure to comply with any section of this NOA shall be cause for termination and removal of NOA.

ADVERTISEMENT: The NOA number preceded by the words Miami-Dade County, Florida, and followed by the expiration date may be displayed in advertising literature. If any portion of the NOA is displayed, then it shall be done in its entirety.

INSPECTION: A copy of this entire NOA shall be provided to the user by the manufacturer or its distributors and shall be available for inspection at the job site at the request of the Building Official.

This NOA consists of this page 1 and evidence page E-1, as well as approval document mentioned above. The submitted documentation was reviewed by **Carlos M. Utrera, P.E.**



03/28/24

NOA No. 23-0823.05
Expiration Date: April 4, 2029
Approval Date: April 4, 2024
Page 1

NOTICE OF ACCEPTANCE: EVIDENCE SUBMITTED

A. DRAWINGS

1. Drawing No. **1609HM-NOA**, titled “BOM, Notes, Anchors, Elevation, Mull Details, Assembly Details, Head/Sill, Jamb, Profiles”, sheets 1 through 7 of 7, prepared by manufacturer, dated 05/27/2021, signed and sealed by Lucas A. Turner, P.E. on 03/07/2024.

B. TESTS

1. Test reports on: 1) Uniform Static Air Pressure Test, Loading per FBC, TAS 202-94
2) Large Missile Impact Test per FBC, TAS 201-94
3) Cyclic Wind Pressure Loading per FBC, TAS 203-94
along with installation diagram of Model 1609HM Louver Systems, prepared by Intertek, Test Report No. **K4977.01-801-18-r1**, dated 02/04/2022, revised on 05/23/2022, signed and sealed by Tyler Westerling, P.E.
2. Test Report on Test Method for Louvers Impacted by Wind Borne Debris per ANSI/AMCA 540-13 on a Model 1609HM Aluminum Louver Systems, prepared by Intertek, Test Report No. **K4975.01-801-18-R2**, dated 06/28/2021, revised on 01/04/2022, signed and sealed by Tyler Westerling, P.E.
3. Test Report on High Velocity Wind Driven Rain Resistance per ANSI/AMCA 550-15 on a Model 1609HM Aluminum Louver System, prepared by Intertek, Test Report No. **K4976.01-801-44-R2**, dated 05/06/2021, revised on 01/21/2022, signed and sealed by Tyler Westerling, P.E.

C. CALCULATIONS

1. Louver structural calculations, dated 08/09/2023, prepared by Turner Engineering Consulting, Inc., signed and sealed by Lucas A. Turner, P.E.

D. QUALITY ASSURANCE

1. Miami-Dade Department of Regulatory and Economic Resources (RER).

E. MATERIAL CERTIFICATIONS

1. None.

F. STATEMENTS

1. Statement letter of code conformance to the **FBC, 7th Edition (2020)** and **FBC, 8th Edition (2023)**, issued by Turner Engineering Consulting, Inc., dated 08/09/2023, signed and sealed by Lucas A. Turner, P.E.
2. Statement letter of no financial interest issued by Turner Engineering Consulting, Inc., dated 08/09/2023, signed and sealed by Lucas A. Turner, P.E.



Carlos M. Utrera, P.E.
Product Control Examiner
NOA No. 23-0823.05
Expiration Date: April 4, 2029
Approval Date: April 4, 2024

GENERAL NOTES

1. THE 1609HM LOUVER SYSTEM SHOWN IN THE CONFIGURATIONS HEREIN IS DESIGNED AND MANUFACTURED TO COMPLY WITH THE REQUIREMENTS OF THE 8TH EDITION (2023) FLORIDA BUILDING CODE INCLUDING THE HIGH VELOCITY HURRICANE ZONE PROVISIONS, FOR APPLICATIONS WITH DESIGN PRESSURE (ASD) REQUIREMENTS OF 160 PSF OR LESS.
2. THIS PRODUCT HAS BEEN TESTED IN ACCORDANCE WITH TAS 100A, TAS 201, TAS 202, TAS 203, AMCA 540 AND AMCA 550. FOR FULL PRODUCT TESTING DETAILS SEE INTERTEK TEST REPORTS K4975.01-801-18-R2, K4976.01-801-44-R2, AND K4977.01-801-18-R1.
3. THIS PRODUCT AS SHOWN IN THIS DRAWING IS MISSILE LEVEL E (9 LB 2X4, 80 FPS) LARGE MISSILE IMPACT RESISTANT, AND DOES NOT REQUIRE THE USE OF IMPACT PROTECTIVE DEVICES (SHUTTERS) IN WINDBORNE DEBRIS REGIONS.
4. THIS LOUVER SYSTEM HAS BEEN TESTED IN ACCORDANCE WITH TAS 100A TO PREVENT WIND-DRIVEN RAIN FROM PENETRATING THE SPACE BEHIND THE LOUVER FOR WIND SPEEDS UP TO 110 MPH AND INSTALLATION IN HEIGHTS UP TO 33 FT.
5. THIS LOUVER SYSTEM IS NON-BEARING AND IS NOT DESIGNED TO WITHSTAND BUILDING DEAD LOADS.
6. THE 4/3 ALLOWABLE STRESS INCREASE FACTOR (SHORT-TERM INCREASE FACTOR) HAS NOT BEEN USED IN THE ANCHOR ANALYSIS FOR THIS SYSTEM. THE 1.6 Cd FACTOR WAS USED IN THE ANALYSIS OF ANCHORAGE INTO WOOD SUBSTRATE.
7. THE OPENING SUBSTRATE MATERIALS (FRAMING, MASONRY, BUCKS) AND ATTACHMENT OF BUCKS TO THE SUBSTRATE ARE BY OTHERS AND SHALL BE VERIFIED BY THE ARCHITECT OR ENGINEER OF RECORD OR AS APPROVED BY THE AUTHORITY HAVING JURISDICTION (AHJ). BUCKING, OPENINGS, & BUCKING FASTENERS MUST BE PROPERLY DESIGNED & INSTALLED BY OTHERS IN ACCORDANCE WITH THE FBC TO TRANSFER SUPERIMPOSED LOADS TO THE STRUCTURE.
8. DISSIMILAR MATERIALS THAT COME INTO CONTACT SHALL BE COATED OR OTHERWISE PROTECTED TO PREVENT GALVANIC REACTIONS. WOOD BUCKS, IF USED, SHALL BE PRESSURE TREATED, WITH EITHER A TREATMENT OR COATING COMPATIBLE WITH THIS PRODUCT.
9. ANCHORAGE NOTES: INSTALL PRODUCTS WITH MAXIMUM SHIM GAP, MINIMUM EDGE DISTANCE AND EMBEDMENT, AND WITH FASTENER TYPE AS SHOWN IN THE DETAILS AND AS INDICATED IN TABLE 1 FOR THE APPROPRIATE SUBSTRATE, OR AS APPROVED, SIGNED, AND SEALED BY A FLORIDA-REGISTERED PROFESSIONAL ENGINEER ON A SITE-SPECIFIC BASIS. ALL ANCHORS USED SHALL BE OF A MATERIAL OR HAVE A COATING COMPATIBLE WITH THE OPENING SUBSTRATE AND ALL OTHER LOUVER MATERIALS. INSTALL ONE ANCHOR AT EACH LOCATION SHOWN IN THE ELEVATION. INSTALL SHIMS AT EACH ANCHOR LOCATION WHERE A GAP OF 1/16" OR GREATER EXISTS BETWEEN PRODUCT FRAME AND SUBSTRATE. SHIMS SHALL BE LOAD-BEARING (PLASTIC OR METALLIC) AND CAPABLE OF TRANSFERRING LOADS TO SUBSTRATE. SPECIFIED ANCHOR EMBEDMENT TO SUBSTRATE SHALL BE BEYOND WALL FINISH OR STUCCO.

TABLE 1. INSTALLATION ANCHOR REQUIREMENTS (NOTE: THIS TABLE APPLIES TO ANCHORAGE OF BOTH 1.5X2 AND 5X6 ANGLES)						
ANCHOR ID	OPENING SUBSTRATE	ANCHOR TO OPENING FASTENER TYPE	MINIMUM EMBEDMENT	MINIMUM EDGE DISTANCE	MAX. O.C. DISTANCE, ATTACHMENT OF 1.5X2X1/8 ANGLE	MAX. O.C. DISTANCE, ATTACHMENT OF 5X6X3/8 ANGLE
A	SOLID UNCRACKED CONCRETE (4000 PSI MIN.)	3/8" DEWALT COATED CARBON STEEL SCREW-BOLT+	2 1/2"	1 1/2"	3 1/4"	9"
B	GROUT- FILLED CMU (ASTM C-90 WITH 1,500 PSI MIN. GROUT)	3/8" DEWALT COATED CARBON STEEL SCREW-BOLT+	3 1/4"	1 1/2"	3 1/4"	9"
C	1/4" THICK MIN. A36 MIN. STEEL	3/8"-16 BOLT, 300 SERIES COND. CW SS (65ksi MIN. YIELD)	1/4"	9/16"	3 1/4"	9"
D	SOUTHERN PINE (SG = 0.55 MIN.)	3/8" LAG SCREW, 300 SERIES COND. CW SS (65ksi MIN. YIELD)	3"	1 1/2"	3 1/4"	5"

TABLE OF CONTENTS

SHEET	DESCRIPTION
1	NOTES, ANCHOR TABLE 1, BOM
2	TYP. SINGLE LOUVER ASSEMBLY
3	TYP. MULLED LOUVER ASSEMBLY
4	VERT. SECTION / INSTALLATION
5	HORIZ. SECTION / INSTALLATION
6	PROFILES

BILL OF MATERIALS, MISCELLANEOUS COMPONENTS

ITEM	INTERNAL ID	DESCRIPTION
1	C6-189	SCREW, MACHINE, HW, #10-24 X 1 1/2,
2	C6-192	SCREW, MACHINE, HEX, #10 X 1 1/2,
3	C6-193	SCREWM METAL, HEX, #14 X 1 1/2,
4	C6-198	SCREW, MTL, HEX, #8 X 3/4,
5	-	SEALANT & BACKER ROD
6	-	3/8 NYLON INSERT LOCKNUT
7	-	3/8 COMM'L FLAT WASHER
8	-	3/8-16 X 1 HEX CAP SCREW 18-8 SS
9	-	INSTALL ANCHOR, SEE TABLE 1, SHEET 1

BILL OF MATERIALS, 6063-T6 ALUMINUM COMPONENTS

ITEM	INTERNAL ID	DESCRIPTION
10	C6-144	1604 HD HEAD/SILL FRAME
20	C6-146	1604 HD JAMB FRAME
30	C6-215A	1604 J BLADE
40	C6-216A	BLADE BRACE
50	C6-119	1605WD HEAD/SILL
60	C6-199	1605WDF JAMB FRAME
70	C6-203	1605 WD BLADE
80	XX-XXX	BAFFLE
90	XX-XXX	JAMB BLOCK OFF
100	XX-XXX	SILL BLOCKOFF
110	C6-179	MULLION BAR
120	C6-133	4 in CHANNEL FRAME
130	XX-XXX	BLANK OFF (0.125" THICK 5052-H32 ALUM.)
140	C6-173	MULLION COVER
150	C6-161B	3 x 6 x 1/4 ALUM ANGLE (CONT)
160	C6-176	1 1/2 x 2 x 1/8 ANGLE (CONT)
170	XX-XXX	5 x 6 x 3/8 ALUM WALL ANGLE (CONT)

PRODUCT APPROVED
as complying with the Florida Building Code
NOA-No. 23-0823.05
Approval Date 04/04/2024
By *[Signature]*
Miami-Dade Product Control

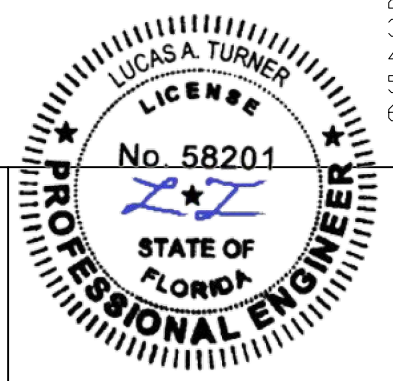

3/7/2024
LUCAS TURNER
FL PE 58201
TURNER ENGINEERING & CONSULTING, INC.,
2428 OLD NATCHEZ TRACE TRL.
CAMDEN, TN, 38320
PH 941-380-1574



Nailor Industries Inc.
4714 Winfield Road
Houston, TX 77039
TEL: 281-590-1172
FAX: 281-590-3086

REV	BY	DESCRIPTION	DATE
DWN BY:	fcoartinas	SCALE:	NTS
DATE:	5/27/2021	SHEET:	1 OF 7
SHEET DESCRIPTION: BOM, NOTES, ANCHORS			REV
DWG: 1609HM-NOA			0

TYPICAL ASSEMBLY, SINGLE LOUVER SECTION

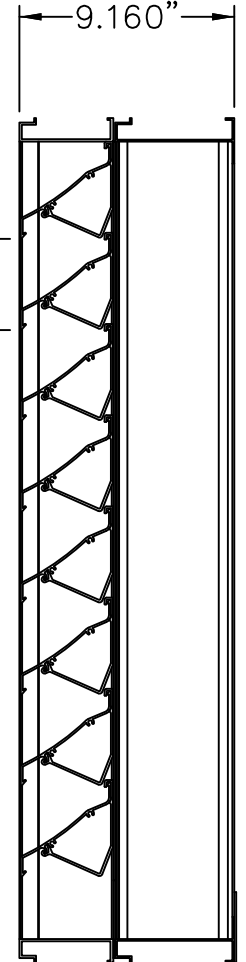
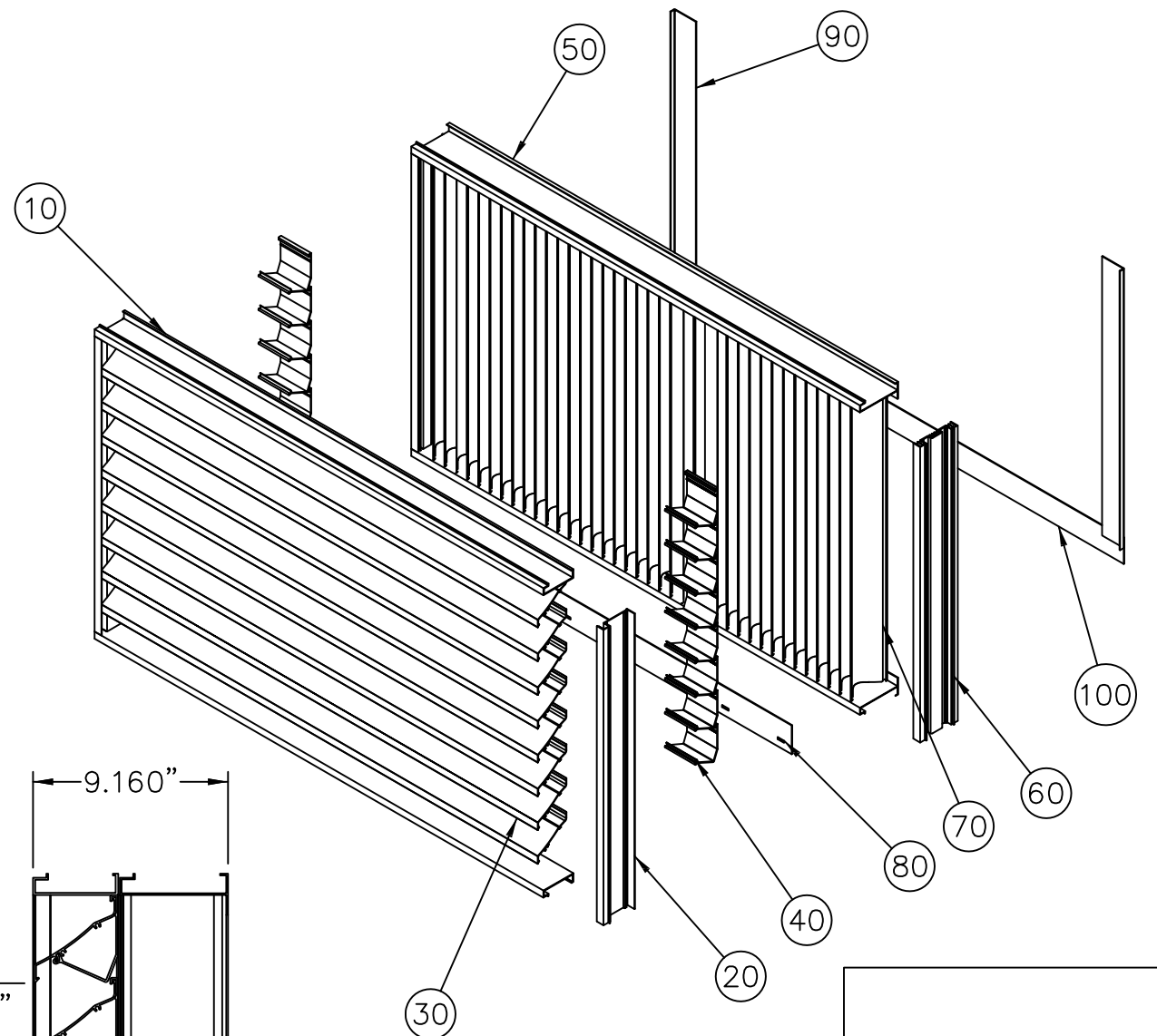
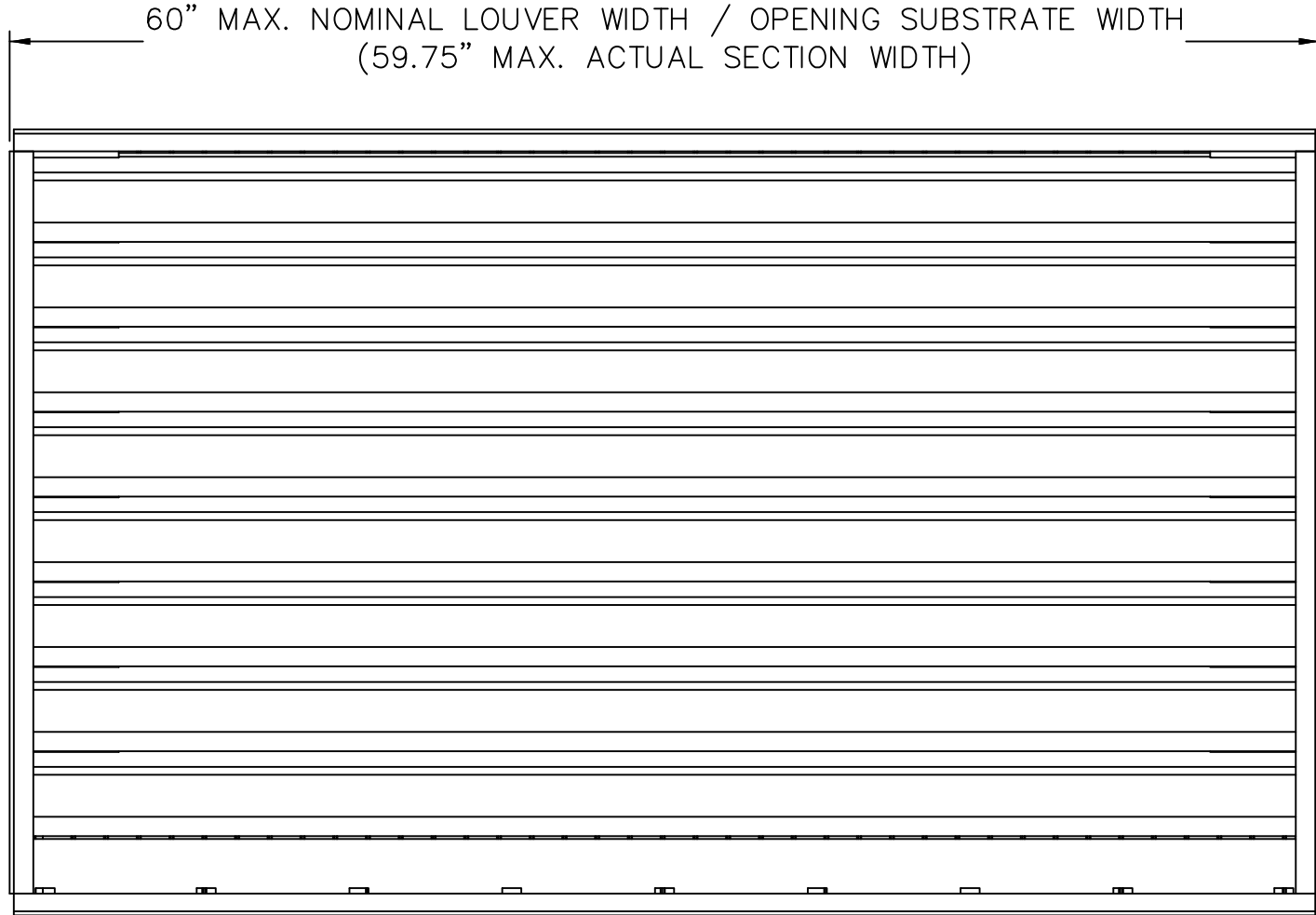
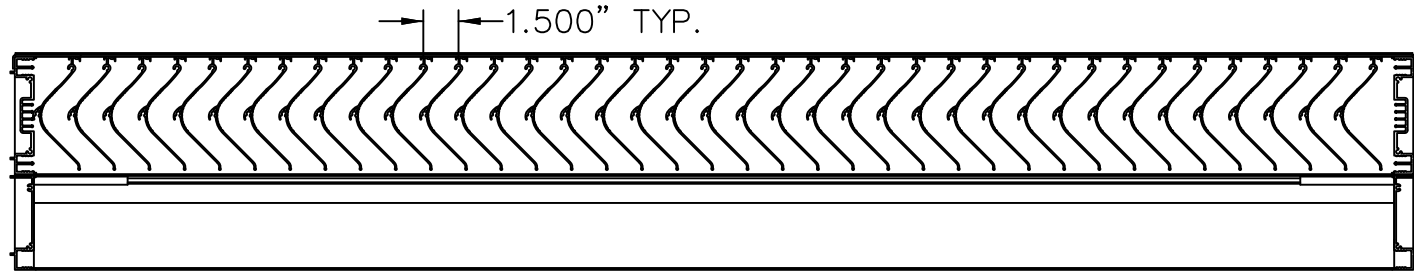

PRODUCT APPROVED
as complying with the Florida
Building Code
NOA-No. 23-0823.05
Approval Date 04/04/2024
By *[Signature]*
Miami-Dade Product Control

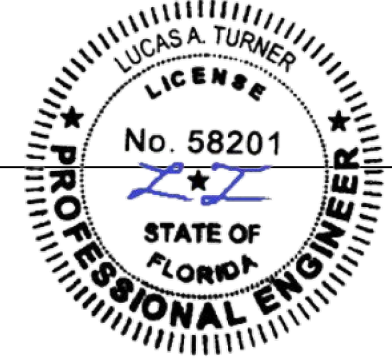

3/7/2024
LUCAS TURNER
FL PE 58201
TURNER ENGINEERING &
CONSULTING, INC.,
2428 OLD NATCHEZ TRACE TRL.
CAMDEN, TN, 38320
PH 941-380-1574



Nailor Industries Inc.
4714 Winfield Road
Houston, TX 77039
TEL: 281-590-1172
FAX: 281-590-3086

REV	BY	DESCRIPTION	DATE
DWN BY:	fcortinas	SCALE:	NTS
DATE:	5/27/2021	SHEET:	2 OF 7
SHEET DESCRIPTION: 1609HM 60.00 X 36.00			REV
DWG: 1609HM-NOA			0

TYPICAL ASSEMBLY, MULLED LOUVERS
(TWO LOUVER SECTIONS SHOWN, BUT
UNLIMITED SECTIONS MAY BE MULLED)

OPTIONAL BLANKED
OFF BACK ASSEMBLY

1.500" TYP.

30" MAX. NOMINAL WIDTH @
BLANK OFF BACK ASSEMBLY
(29.75" MAX. ACTUAL
SECTION WIDTH)

60" MAX. NOMINAL WIDTH @
LOUVER BACK ASSEMBLY
(59.75" MAX. ACTUAL
SECTION WIDTH)

OVERALL NOMINAL LOUVER WIDTH /
SUBSTRATE OPENING WIDTH
= SUM OF NOMINAL WIDTHS OF ALL MULLED SECTIONS

120" MAX.
NOMINAL
LOUVER /
SUBSTRATE
OPENING
HEIGHT
(119.75"
MAX.
ACTUAL
LOUVER/
SECTION
HEIGHT)

3.889"
TYP.

9.160"

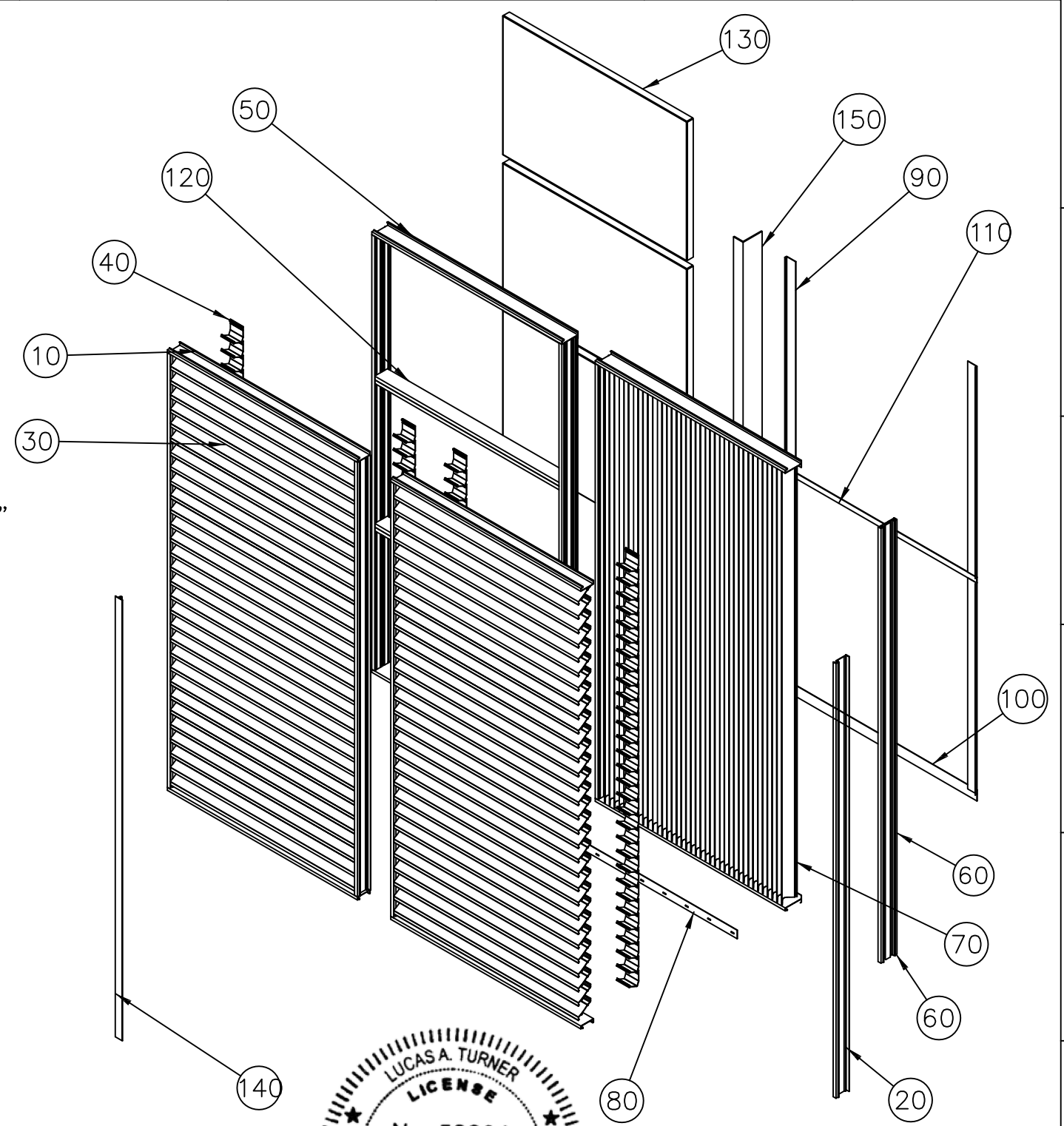

PRODUCT APPROVED
as complying with the Florida
Building Code
NOA-No. 23-0823.05
Approval Date 04/04/2024
By *[Signature]*
Miami-Dade Product Control

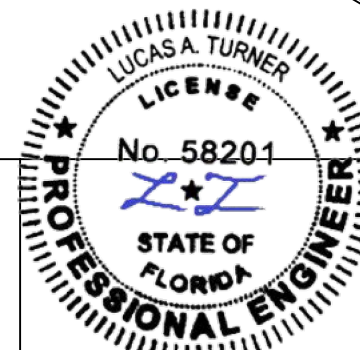

3/7/2024
LUCAS TURNER
FL PE 58201
TURNER ENGINEERING &
CONSULTING, INC.,
2428 OLD NATCHEZ TRACE TRL.
CAMDEN, TN, 38320
PH 941-380-1574



Nailor Industries Inc.

4714 Winfield Road
Houston, TX 77039
TEL: 281-590-1172
FAX: 281-590-3086

REV	BY	DESCRIPTION	DATE
DWN BY:	fcortinas	SCALE:	NTS
DATE:	5/27/2021	SHEET:	3 OF 7
SHEET DESCRIP.:	1609HM 120.00 X 120.00		REV
DWG:	1609HM-NOA		0

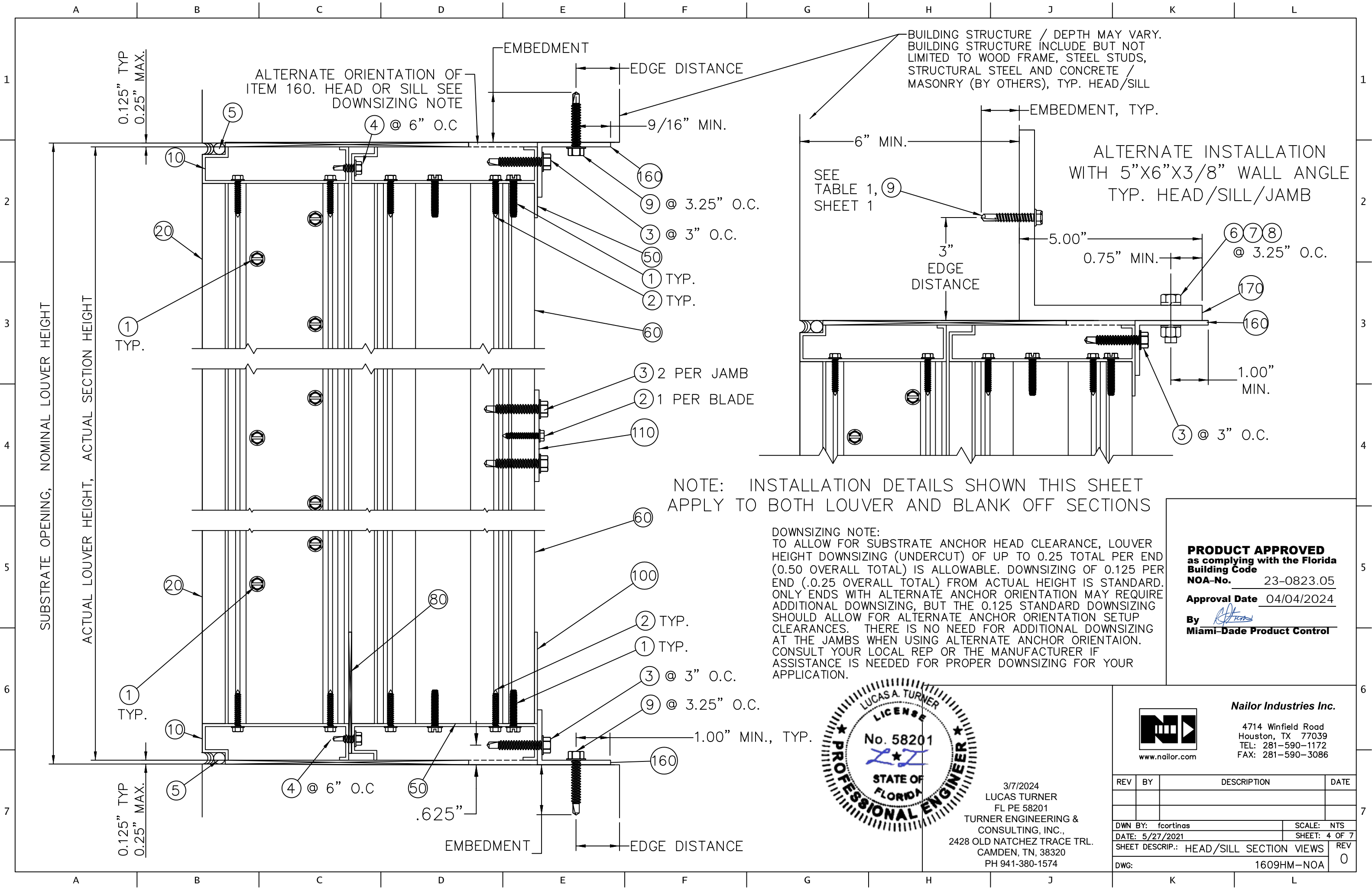

ALTERNATE ORIENTATION OF ITEM 160. HEAD OR SILL SEE DOWNSIZING NOTE

BUILDING STRUCTURE / DEPTH MAY VARY. BUILDING STRUCTURE INCLUDE BUT NOT LIMITED TO WOOD FRAME, STEEL STUDS, STRUCTURAL STEEL AND CONCRETE / MASONRY (BY OTHERS), TYP. HEAD/SILL

ALTERNATE INSTALLATION WITH 5"x6"x3/8" WALL ANGLE TYP. HEAD/SILL/JAMB

NOTE: INSTALLATION DETAILS SHOWN THIS SHEET APPLY TO BOTH LOUVER AND BLANK OFF SECTIONS

DOWNSIZING NOTE:
 TO ALLOW FOR SUBSTRATE ANCHOR HEAD CLEARANCE, LOUVER HEIGHT DOWNSIZING (UNDERCUT) OF UP TO 0.25 TOTAL PER END (0.50 OVERALL TOTAL) IS ALLOWABLE. DOWNSIZING OF 0.125 PER END (.025 OVERALL TOTAL) FROM ACTUAL HEIGHT IS STANDARD. ONLY ENDS WITH ALTERNATE ANCHOR ORIENTATION MAY REQUIRE ADDITIONAL DOWNSIZING, BUT THE 0.125 STANDARD DOWNSIZING SHOULD ALLOW FOR ALTERNATE ANCHOR ORIENTATION SETUP CLEARANCES. THERE IS NO NEED FOR ADDITIONAL DOWNSIZING AT THE JAMBS WHEN USING ALTERNATE ANCHOR ORIENTATION. CONSULT YOUR LOCAL REP OR THE MANUFACTURER IF ASSISTANCE IS NEEDED FOR PROPER DOWNSIZING FOR YOUR APPLICATION.

PRODUCT APPROVED
 as complying with the Florida Building Code
 NOA-No. 23-0823.05
 Approval Date 04/04/2024
 By *[Signature]*
 Miami-Dade Product Control

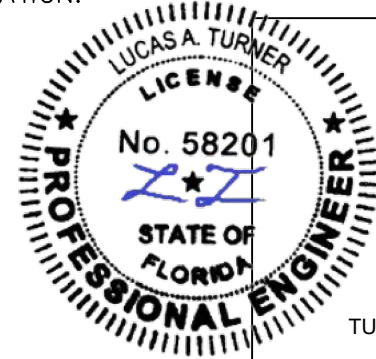

3/7/2024
 LUCAS TURNER
 FL PE 58201
 TURNER ENGINEERING & CONSULTING, INC.,
 2428 OLD NATCHEZ TRACE TRL.
 CAMDEN, TN, 38320
 PH 941-380-1574



Nailor Industries Inc.
 4714 Winfield Road
 Houston, TX 77039
 TEL: 281-590-1172
 FAX: 281-590-3086

REV	BY	DESCRIPTION	DATE
DWN BY:	fcorinas	SCALE:	NTS
DATE:	5/27/2021	SHEET:	4 OF 7
SHEET DESCR.:	HEAD/SILL SECTION VIEWS		
DWG:	1609HM-NOA		
		REV	0

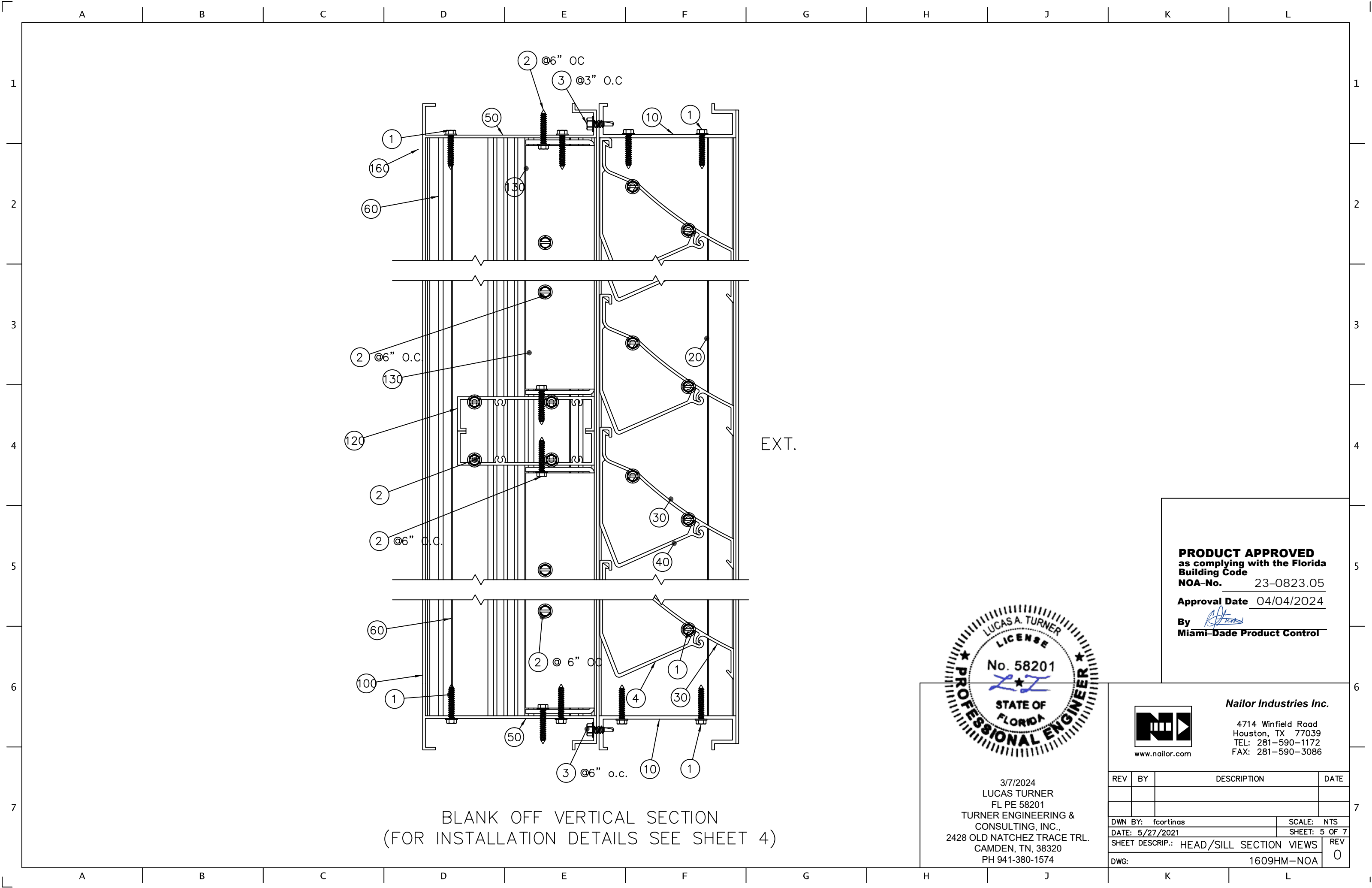

BLANK OFF VERTICAL SECTION
(FOR INSTALLATION DETAILS SEE SHEET 4)

EXT.

PRODUCT APPROVED
as complying with the Florida
Building Code
NOA-No. 23-0823.05
Approval Date 04/04/2024
By *[Signature]*
Miami-Dade Product Control

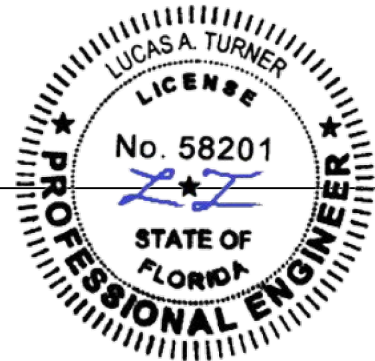

3/7/2024
LUCAS TURNER
FL PE 58201
TURNER ENGINEERING &
CONSULTING, INC.,
2428 OLD NATCHEZ TRACE TRL.
CAMDEN, TN, 38320
PH 941-380-1574



Nailor Industries Inc.
4714 Winfield Road
Houston, TX 77039
TEL: 281-590-1172
FAX: 281-590-3086

REV	BY	DESCRIPTION	DATE
DWN BY: fcartinas		SCALE: NTS	
DATE: 5/27/2021		SHEET: 5 OF 7	
SHEET DESCRIP.: HEAD/SILL SECTION VIEWS			REV
DWG: 1609HM-NOA			0

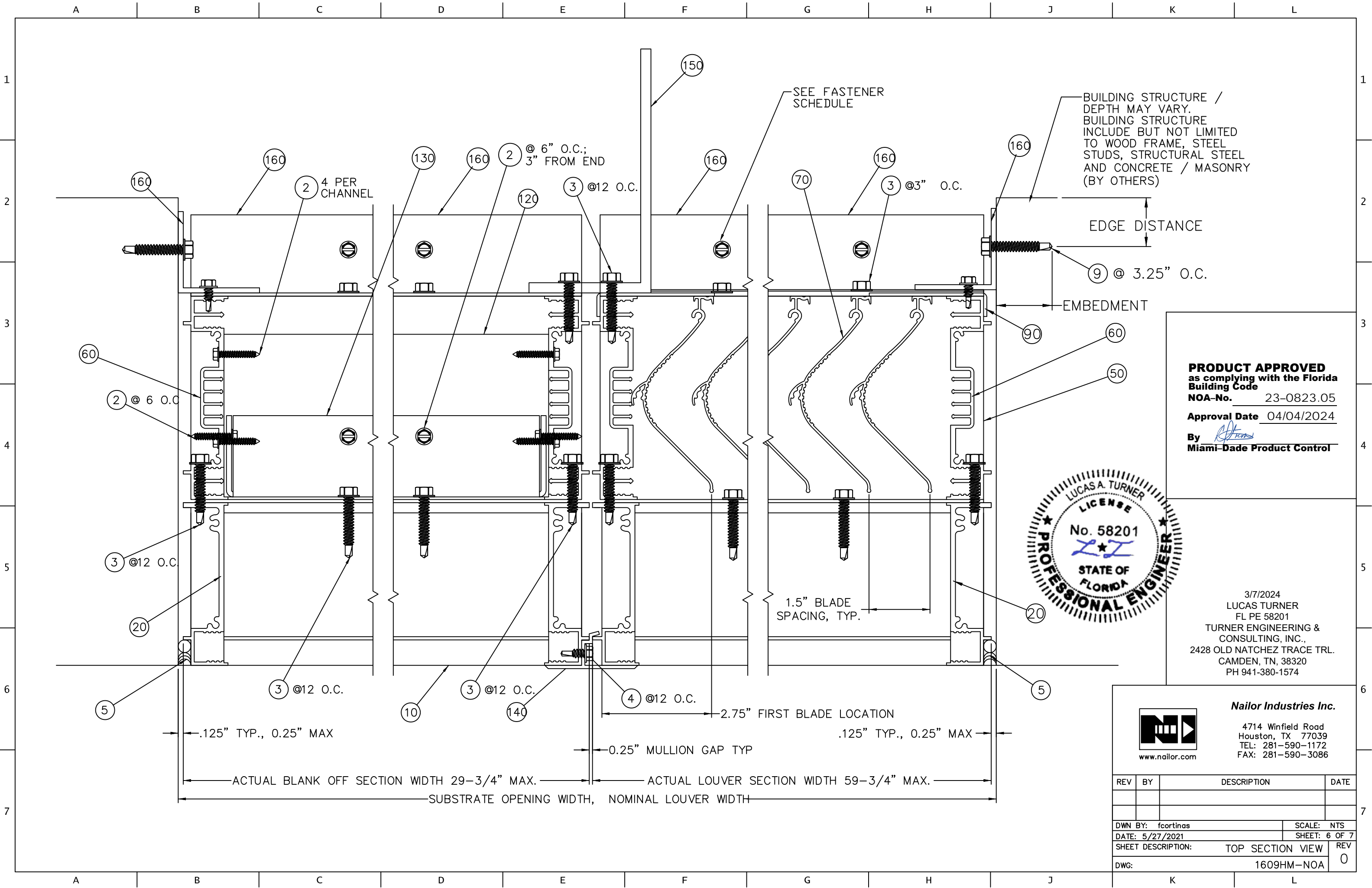

BUILDING STRUCTURE /
DEPTH MAY VARY.
BUILDING STRUCTURE
INCLUDE BUT NOT LIMITED
TO WOOD FRAME, STEEL
STUDS, STRUCTURAL STEEL
AND CONCRETE / MASONRY
(BY OTHERS)

PRODUCT APPROVED
as complying with the Florida
Building Code
NOA-No. 23-0823.05
Approval Date 04/04/2024
By *[Signature]*
Miami-Dade Product Control

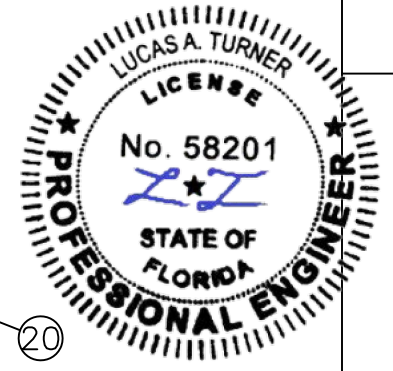

3/7/2024
LUCAS TURNER
FL PE 58201
TURNER ENGINEERING &
CONSULTING, INC.,
2428 OLD NATCHEZ TRACE TRL.
CAMDEN, TN, 38320
PH 941-380-1574



Nailor Industries Inc.
4714 Winfield Road
Houston, TX 77039
TEL: 281-590-1172
FAX: 281-590-3086
www.nailor.com

REV	BY	DESCRIPTION	DATE

DWN BY: fcartinas SCALE: NTS
DATE: 5/27/2021 SHEET: 6 OF 7
SHEET DESCRIPTION: TOP SECTION VIEW REV 0
DWG: 1609HM-NOA

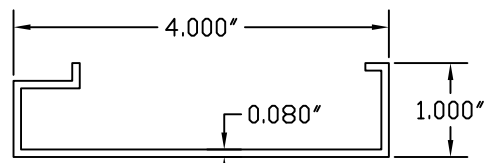

10 1604 HD HEAD/SILL FRAME

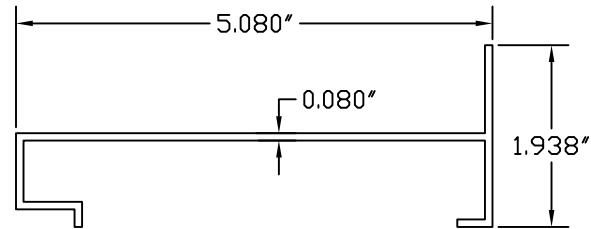

50 1605WD HEAD/SILL

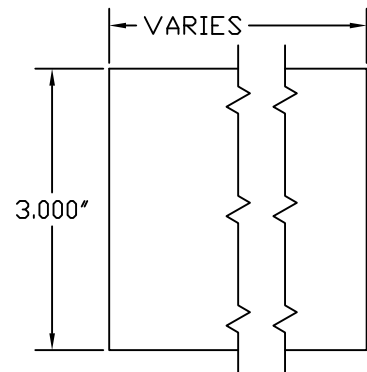

100 SILL BLOCKOFF

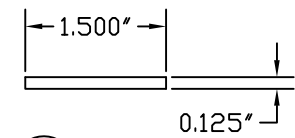

110 MULLION BAR

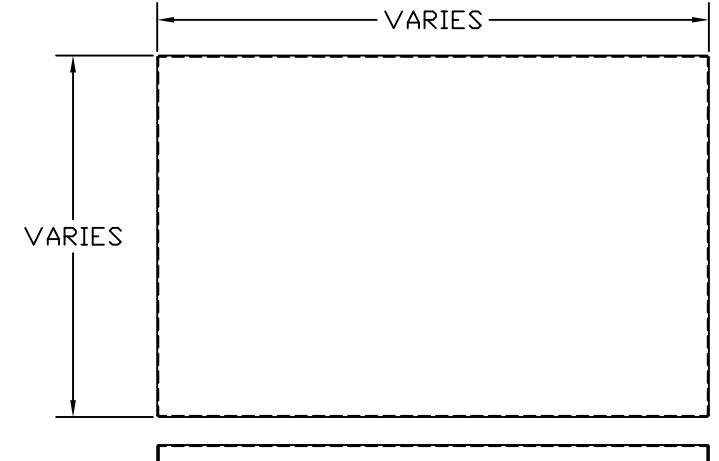

130 BLANKOFF (0.125" THICK)

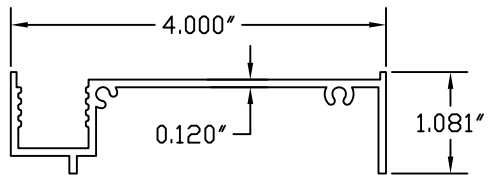

20 1604 HD JAMB FRAME

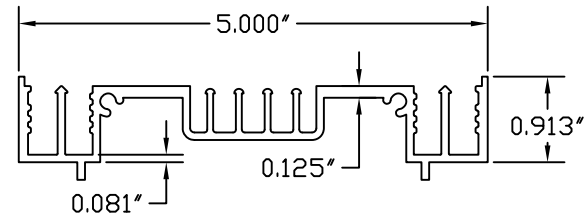

60 1605WDF JAMB FRAME

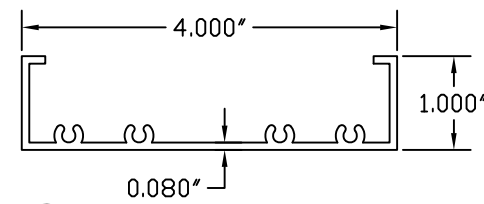

120 4" CHANNEL FRAME

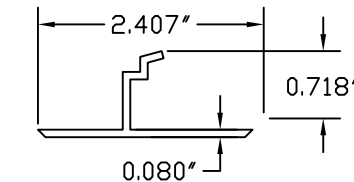

140 MULLION COVER

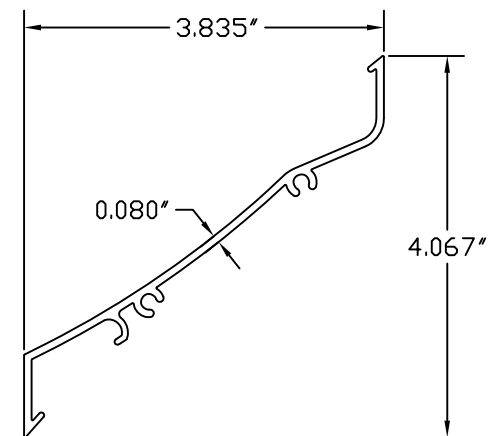

30 1604J BLADE

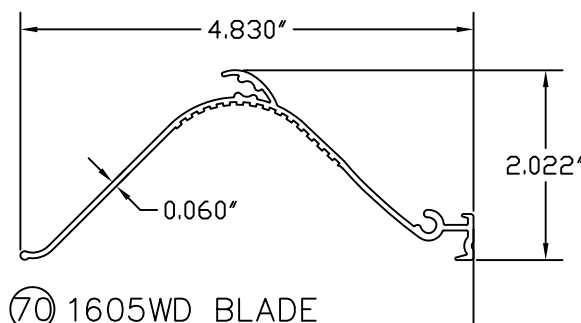

70 1605WD BLADE

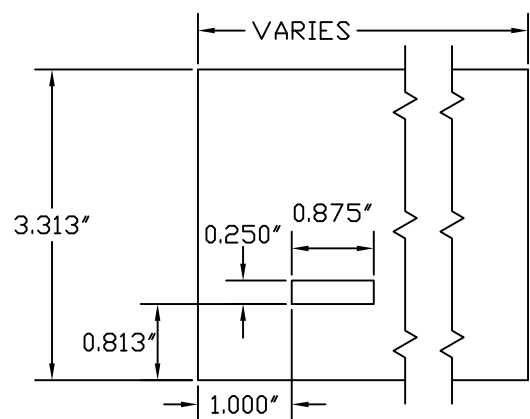

80 BAFFLE (0.093" THICK)

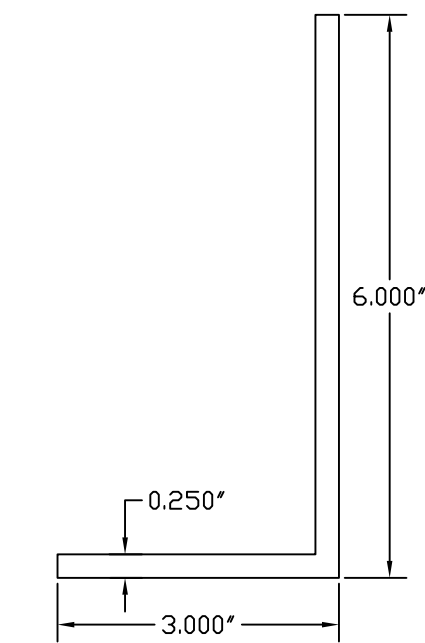

150 3X6 ALUM. ANGLE

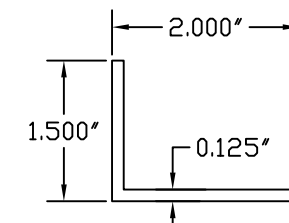

160 1.5X2X1/8 ANGLE MOUNT

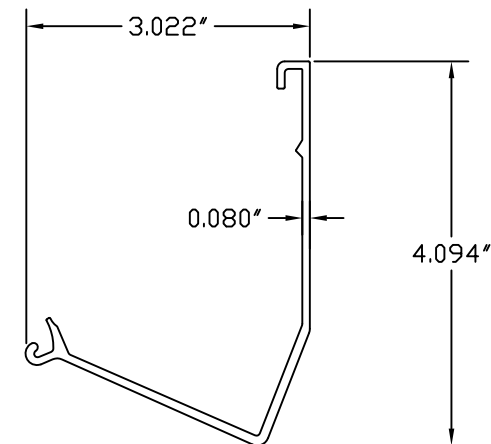

40 BLADE BRACE

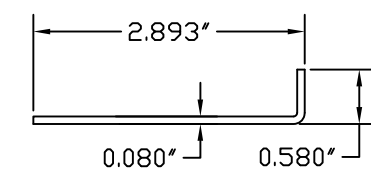

90 JAMB BLOCK OFF

PRODUCT APPROVED
as complying with the Florida
Building Code
NOA-No. 23-0823.05
Approval Date 04/04/2024
By *[Signature]*
Miami-Dade Product Control

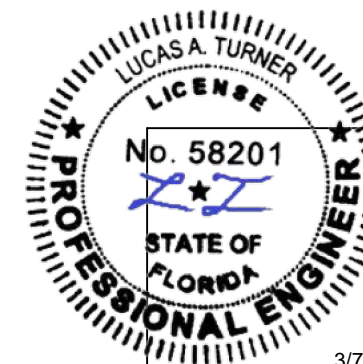

3/7/2024
LUCAS TURNER
FL PE 58201
TURNER ENGINEERING &
CONSULTING, INC.,
2428 OLD NATCHEZ TRACE TRL.
CAMDEN, TN, 38320
PH 941-380-1574



Nailor Industries Inc.

4714 Winfield Road
Houston, TX 77039
TEL: 281-590-1172
FAX: 281-590-3086

REV	BY	DESCRIPTION	DATE
DWN BY: fcorinas		SCALE: NTS	
DATE: 5/27/2021		SHEET: 7 OF 7	
SHEET DESCRIPTION: PROFILES		REV	
DWG: 1609HM-NOA		0	