



DEPARTMENT OF REGULATORY AND ECONOMIC RESOURCES (RER)
BOARD AND CODE ADMINISTRATION DIVISION

NOTICE OF ACCEPTANCE (NOA)

MIAMI-DADE COUNTY
PRODUCT CONTROL SECTION

11805 SW 26 Street, Room 208
Miami, Florida 33175-2474
T (786) 315-2590 F (786) 315-2599

www.miamidade.gov/economy

Clopay Corporation
8585 Duke Boulevard
Mason, OH 45040

SCOPE: This NOA is being issued under the applicable rules and regulations governing the use of construction materials. The documentation submitted has been reviewed and accepted by Miami-Dade County RER-Product Control Section to be used in Miami Dade County and other areas, where allowed by the Authority Having Jurisdiction (AHJ).

This NOA shall not be valid after the expiration date stated below. The Miami-Dade County Product Control Section (In Miami-Dade County) and/or the AHJ (in areas other than Miami-Dade County) reserve the right to have this product or material tested for quality assurance purposes. If this product or material fails to perform in the accepted manner, the manufacturer will incur the expense of such testing and the AHJ may immediately revoke, modify, or suspend the use of such product or material within their jurisdiction. RER reserves the right to revoke this acceptance, if it is determined by Miami-Dade County Product Control Section that this product or material fails to meet the requirements of the applicable building code.

This product is approved as described herein and has been designed to comply with the Florida Building Code, including the High Velocity Hurricane Zone.

DESCRIPTION: Modern 2in. Intellicore Insulated W6 DP38T Steel Sectional Garage Door up to 18ft.-2in. Wide w/ Optional Impact Resistant Lites

APPROVAL DOCUMENT: Drawing No. **105188**, titled “Modern Steel 2” Intellicore +38/ -42 psf to 18’ Wide”, sheets 1 through 4 of 4, dated 06/20/2017, with revision **03** dated 09/07/2023, prepared by Clopay Corporation, , signed and sealed by Mark Westerfield, P.E., bearing the Miami-Dade County Product Control renewal stamp with the Notice of Acceptance number and expiration date by the Miami-Dade County Product Control Section.

MISSILE IMPACT RATING: Large and Small Missile Impact Resistant

LABELING: A permanent label with the manufacturer’s name or logo, manufacturing address, model number, the positive and negative design pressure rating, indicate impact rated if applicable, installation instruction drawing reference number, approval number (NOA), the applicable test standards, and the statement reading ‘Miami-Dade County Product Control Approved’ is to be located on the door’s side track, bottom angle, or inner surface of a panel.

RENEWAL of this NOA shall be considered after a renewal application has been filed and there has been no change in the applicable building code negatively affecting the performance of this product.

TERMINATION of this NOA will occur after the expiration date or if there has been a revision or change in the materials, use, and/or manufacture of the product or process. Misuse of this NOA as an endorsement of any product, for sales, advertising or any other purposes shall automatically terminate this NOA. Failure to comply with any section of this NOA shall be cause for termination and removal of NOA.

LIMITATION: This approval requires the manufacturer to do testing of all coils used to fabricate door panels. A minimum of 2 specimens shall be cut from each coil and tensile tested according to ASTM E-8 by a Miami-Dade County approved laboratory. Every 3 months, the manufacturer shall mail to this office a copy of the tested reports. Only coils with average yield strength of 30,000 psi or more shall be used to make door panels for Miami-Dade County under this Notice of Acceptance.

ADVERTISEMENT: The NOA number preceded by the words Miami-Dade County, Florida, and followed by the expiration date may be displayed in advertising literature. If any portion of the NOA is displayed, then it shall be done in its entirety.

INSPECTION: A copy of this entire NOA shall be provided to the user by the manufacturer or its distributors and shall be available for inspection at the job site at the request of the Building Official.

This NOA **revises NOA # 22-1019.02** and consists of this page 1 and evidence pages E-1, E-2, E-3 and E-4, as well as approval document mentioned above.

The submitted documentation was reviewed by **Carlos M. Utrera, P.E.**



NOA-No. 23-0928.63
Expiration Date: December 21, 2027
Approval Date: November 02, 2023
Page 1

NOTICE OF ACCEPTANCE: EVIDENCE SUBMITTED

1. Evidence submitted under previous NOA # 17-0706.03

A. DRAWINGS

1. Drawing No. **105188**, titled “Modern Steel 2” Intellicore +38/ -42 psf to 18’ Wide”, sheets 1 through 4 of 4, dated 06/20/2017, with revision **1** dated 10/25/2017, prepared by Clopay Building Products Company, signed and sealed by Mark Westerfield, P.E.

B. TESTS

1. Test reports on 1) Uniform Static Air Pressure Test, Loading per FBC TAS 202-94
2) Large Missile Impact Test per FBC, TAS 201-94
3) Cyclic Wind Pressure Loading per FBC, TAS 203-94
4) Forced Entry Test, per FBC, TAS 202-94
5) Tensile Test per ASTM E8
along with marked-up drawings and installation diagram of 18’2”x 8’, 27ga (0.016”) steel garage doors Model 9208W6-18T with Lexan polycarbonate windows, prepared by American Test Lab, Inc., Test Report No. **ATLNC 1213.01-16**, dated 12/21/2016, signed and sealed by David W. Johnson, P.E.
2. Test reports on 1) Uniform Static Air Pressure Test, Loading per FBC TAS 202-94
2) Large Missile Impact Test per FBC, TAS 201-94
3) Cyclic Wind Pressure Loading per FBC, TAS 203-94
4) Forced Entry Test, per FBC, TAS 202-94
5) Tensile Test per ASTM E8
along with marked-up drawings and installation diagram of 16’2”x 8’, 27ga steel garage door Model GD2LPW8 with MAK SL and/or MAK 15 windows, prepared by American Test Lab, Inc., Test Report No. **ATLNC 1105-01-13**, dated 01/14/2014, signed and sealed by David W. Johnson, P.E.
3. Test report on Salt Spray per ASTM B117 of painted G40 galvanized painted and G90 panels, prepared by Fenestration Testing Laboratory, Inc., Test Report No. **7890**, dated 10/01/2014, signed by Idalmis Ortega, P.E.

C. CALCULATIONS

1. Jamb anchor calculations prepared by Clopay Building Products Company, dated 06/22/2016, signed and sealed by Mark Westerfield, P.E.



Carlos M. Utrera, P.E.
Product Control Examiner
NOA-No. 23-0928.63
Expiration Date: December 21, 2027
Approval Date: November 02, 2023

NOTICE OF ACCEPTANCE: EVIDENCE SUBMITTED

D. QUALITY ASSURANCE

1. Miami-Dade Department of Regulatory and Economic Resources (RER).

E. MATERIAL CERTIFICATIONS

1. Notice of Acceptance No. **15-0915.08** issued to SABIC Innovative Plastics US, LLC for their Lexan Polycarbonate Sheet Products, approved on 12/10/2015, expiring on 07/17/2018.
2. Notice of Acceptance No. **17-0410.01** issued to Covestro, LLC for their Makrolon Polycarbonate Sheets, approved on 06/08/2017, expiring on 08/27/2022.
3. Test report on Surface Burning Characteristics of the polyurethane foam insulation per ASTM E84, prepared by QAI Laboratories, Test Report No. **RJ2814-3**, dated 10/14/2013, signed by Greg Banasky.
4. Test report on Ignition Temperature of Plastics of the polyurethane foam insulation per ASTM D1929, prepared by UL, LLC, Test Report No. **4786399941/ R5692**, dated 05/20/2014, signed by James Smith.

F. STATEMENTS

1. Statement letter of code conformance to the 5th Edition (2014) and 6th Edition (2017) FBC issued by Clopay Building Products Company, dated 06/26/2017, signed and sealed by Mark Westerfield, P.E.
2. Statement letter of no financial interest issued by Clopay Building Products Company, dated 06/26/2017, signed and sealed by Mark Westerfield, P.E.



Carlos M. Utrera, P.E.
Product Control Examiner
NOA-No. 23-0928.63
Expiration Date: December 21, 2027
Approval Date: November 02, 2023

NOTICE OF ACCEPTANCE: EVIDENCE SUBMITTED

2. EVIDENCE SUBMITTED UNDER NOA # 20-0922.23 AND NEW

A. DRAWINGS

1. Drawing No. **105188**, titled “Modern Steel 2” Intellicore +38/-42 psf to 18’ Wide”, sheets 1 through 4 of 4, dated 06/20/2017, with revision **02** dated 08/24/2020, prepared by Clopay Corporation, signed and sealed by Mark Westerfield, P.E. on 10/12/2022.

B. TESTS

1. None.

C. CALCULATIONS

1. None.

D. QUALITY ASSURANCE

1. Miami-Dade Department of Regulatory and Economic Resources (RER).

E. MATERIAL CERTIFICATIONS

1. None.

F. STATEMENTS

1. Statement letters of code conformance to **6th Edition (2017) and 7th Edition (2020) FBC**, issued by Clopay Corporation, dated 09/15/2020, signed and sealed by Mark Westerfield, P.E.
2. Certificate of amendment changing the company name from Clopay Building Products Company, Inc. to Clopay Corporation, issued by the State of Delaware, dated 08/27/2019.



Carlos M. Utrera, P.E.
Product Control Examiner
NOA-No. 23-0928.63
Expiration Date: December 21, 2027
Approval Date: November 02, 2023

NOTICE OF ACCEPTANCE: EVIDENCE SUBMITTED

3. NEW EVIDENCE SUBMITTED

A. DRAWINGS

1. Drawing No. **105188**, titled “Modern Steel 2” Intellicore +38/-42 psf to 18’ Wide”, sheets 1 through 4 of 4, dated 06/20/2017, with revision **03** dated 09/07/2023, prepared by Clopay Corporation, signed and sealed by Mark Westerfield, P.E.

B. TESTS

1. None.

C. CALCULATIONS

1. None.

D. QUALITY ASSURANCE

1. Miami-Dade Department of Regulatory and Economic Resources (RER).

E. MATERIAL CERTIFICATIONS

1. None.

F. STATEMENTS

1. Statement letters of code conformance to **8th Edition (2023) FBC**, issued by Clopay Corporation, dated 09/15/2023, signed and sealed by Mark Westerfield, P.E.



Carlos M. Utrera, P.E.
Product Control Examiner
NOA-No. 23-0928.63
Expiration Date: December 21, 2027
Approval Date: November 02, 2023

BRAND	MODERN STEEL		COMMERCIAL DOORS	
	FLUSH	GROOVED	FLUSH	GROOVED
CLOPAY	9208, HDPC2	9209, HDPCR2	3728	3729
HOLMES	7208	7209	--	C7R20

SEE SHEET 5 FOR "CANYON RIDGE MODERN SERIES" MODELS.

SHEET:
1 OF 4

REVISIONS					
REV. NO.	ZONE:	DATE:	ECN NO.	APPVD:	DESCRIPTION
00	-	6/20/2017	-	MW	INITIAL RELEASE.
01	-	10/5/17	-	MW	MISC. EDITORIAL UPDATES; ELIMINATED P. 5
02	-	8/24/20	-	MWW	UPDATED TITLE BLOCK AND COMPLIANCE STATEMENT TO 7TH EDITION
03	-	9/7/23	-	JDW	UPDATED CODE COMPLIANCE STATEMENT TO ADD 8TH EDITION

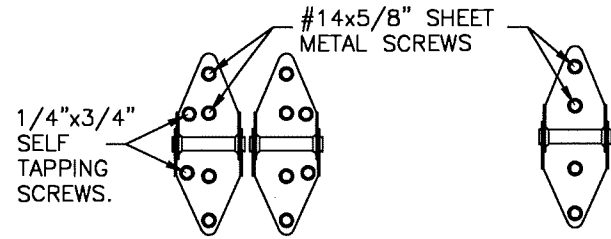

14 GA. END HINGES 14 GA. INTERMEDIATE HINGE
VIEW "B" VIEW "C"

DOOR HEIGHT	# OF SECTIONS	# OF U-BARS	# OF T-STRUTS
6'3" TO 8'0"	4	4	4
8'3" TO 10'0"	5	5	5
10'3" TO 12'0"	6	6	6
12'3" TO 14'0"	7	7	7
14'3" TO 16'0"	8	8	8
16'3" TO 18'0"	9	9	9

MAX SECTION HEIGHT: 24'

2" WIDE X (1) 20 GA. BACKER EXTERNAL PLATE AT EACH INTERMEDIATE HINGE LOCATION, ATTACHED WITH DOUBLE SIDED ACRYLIC ADHESIVE TO BACK OF DOOR.

MIXED GLAZING SHOWN.

(1) #14x5/8 SMS AT THESE LOCATIONS ON THE TOP OF EACH T-STRUT

OPTIONAL IMPACT RESISTANT GLAZING. MAXIMUM GLAZING SIZE (DLO) IS 39-1/4"x13-1/4". GLAZING MAY BE SHORT-PANEL OR LONG-PANEL. SEE SECTION B-B ON SHEET 2 FOR DETAILS. GLAZING MAY BE INSTALLED IN ANY LOCATION IN ANY OR ALL SECTIONS.

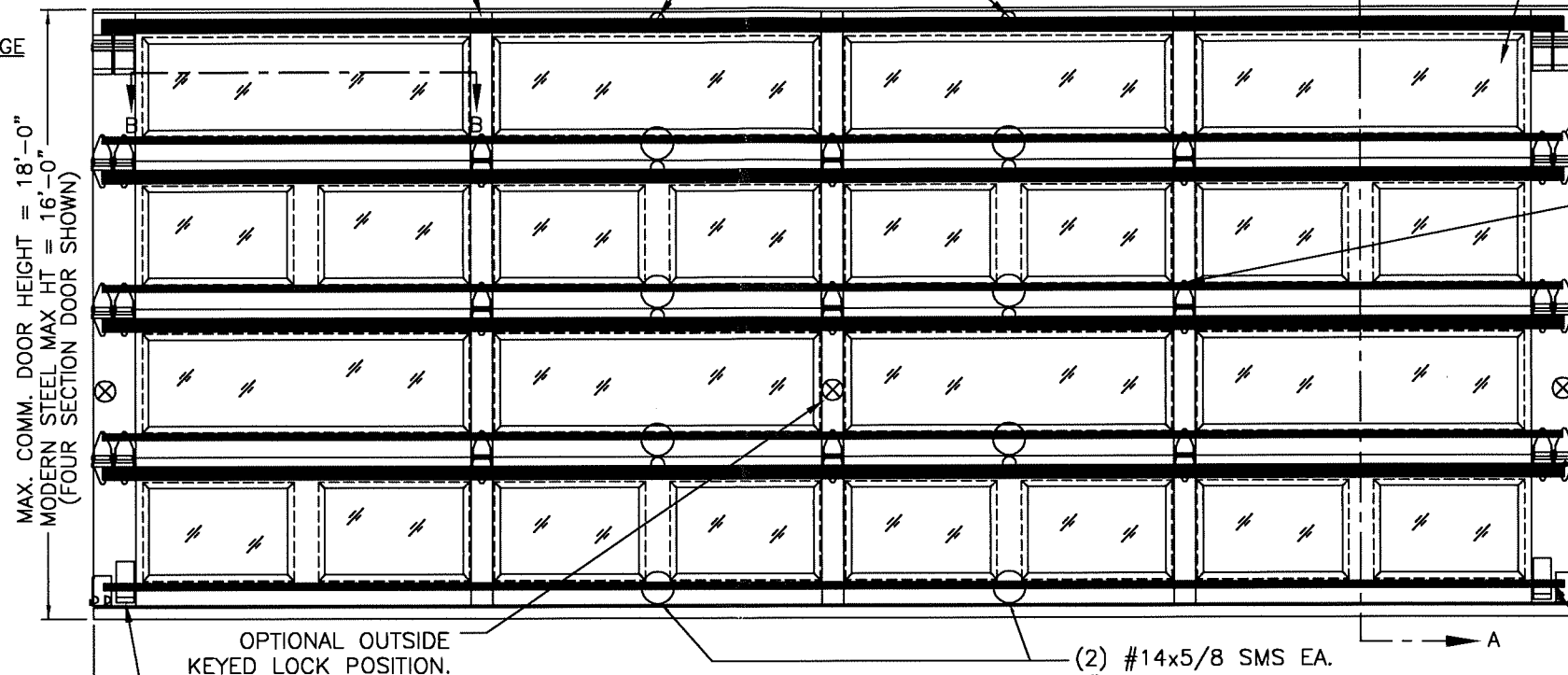

MAX. COMM. DOOR HEIGHT = 18'-0"
MODERN STEEL MAX HT = 16'-0"
(FOUR SECTION DOOR SHOWN)

MAX. DOOR WIDTH = 18'-2"
MAX. OPENING WIDTH = 18'-0"
SEE JAMB NOTES ON SHEET 4.

OPTIONAL OUTSIDE KEYED LOCK POSITION.

(2) LHR TOP BRACKETS USED AS INNER BOTTOM BRACKET.
(1) 3-IN ROLLER CARRIER (P/N 0120394) USED WITH 3" TRACK.

(2) #14x5/8 SMS EA. 3" STRUT LOCATIONS.

SNAP LATCH ENGAGES ONTO VERTICAL TRACK. ONE SNAP LATCH ON EACH SIDE OF DOOR.

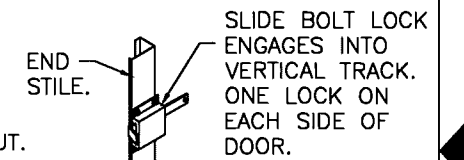

INSIDE SLIDE BOLT LOCK OPTION.

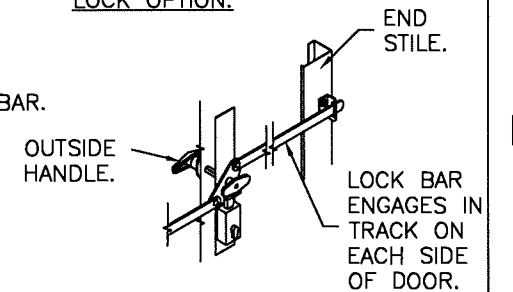

OUTSIDE KEYED LOCK WITH LOCK BAR LOCKING.

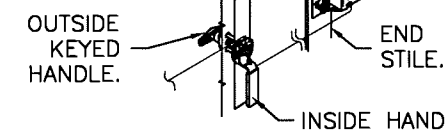

THIS PRODUCT CONFORMS TO THE REQUIREMENTS OF 7TH AND 8TH EDITION OF THE FLORIDA BUILDING CODE

REPRESENTATIVE GLAZING PATTERNS.

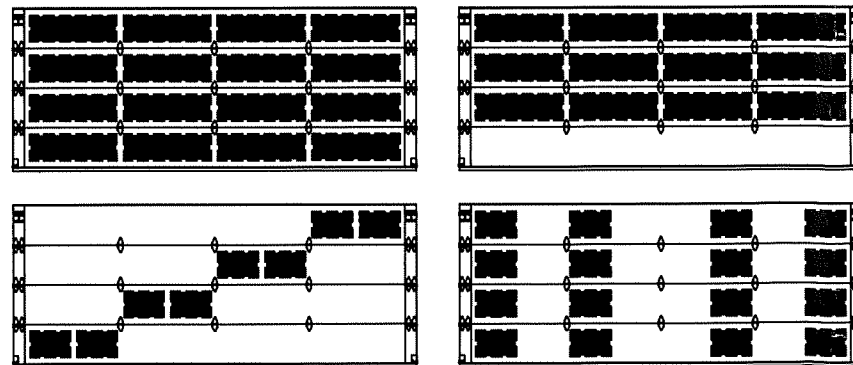

GLAZING MAY BE IN ANY LOCATION IN ANY OR ALL SECTIONS. THESE PATTERNS ARE REPRESENTATIVE OF THE APPROVED CONFIGURATIONS. NOT ALL CONFIGURATIONS ARE AVAILABLE AS STANDARD PRODUCT. CONSULT FACTORY FOR DETAILS.

DESIGN LOADS: +38.0 P.S.F. & -42.0 P.S.F.

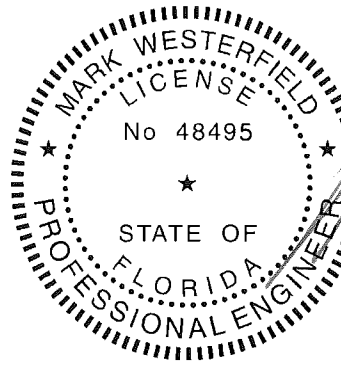

DESIGN ENGINEER:
MARK WESTERFIELD, P.E.
FLORIDA LICENSE No. 48495

PRODUCT REVISED
as complying with the Florida Building Code
NOA-No. 23-0928.63

Expiration Date 12/21/2027

By *[Signature]*
Miami-Dade Product Control

Unless Stated Otherwise TOLERANCES are
.0 = ±.031
.00 = ±.015
.000 = ±.005
.0000 = ±.001
Degrees = ±1/2"

Unless Stated Otherwise DIMENSIONS ARE IN INCHES.

Glopay CORPORATION
8585 Duke Boulevard
Mason, OH 45040 USA
Tel. No. 513-770-4800
Fax No. 513-770-4853

DESCRIPTION: MODERN STEEL 2" INTELICORE +38/-42 PSF TO 18' W

DRAWN BY: SH	DATE: 01/2017	SCALE: NTS	DWG. SIZE B
CHECKED BY: MW	DATE: 6/20/17	SHEET 1 OF 4	
DWG. NO.: 105188	VER: M-D		

MANUFACTURING PRODUCT CODE
DSIU-1F477

PART NO.: N/A

WINDLOAD RATING
W6 DP38T

BRAND	MODERN STEEL		COMMERCIAL DOORS	
	FLUSH	GROOVED	FLUSH	GROOVED
CLOPAY	9208, HDPC2	9209, HDPCR2	3728	3729
HOLMES	7208	7209	--	C7R20

SEE SHEET 5 FOR "CANYON RIDGE MODERN SERIES" MODELS.

SHEET:
2 OF 4

REVISIONS					
REV. NO.	ZONE:	DATE:	ECN NO.	APPVD:	DESCRIPTION
03	-	-	-	-	SEE REVISION HISTORY ON SHEET ONE.

IMPACT-RESISTANT CONSTRUCTION:
 SOLID DOORS (NO GLAZING) OR DOORS WITH OPTIONAL IMPACT-RESISTANT GLAZING ARE IMPACT-RESISTANT. OPTIONAL IMPACT RESISTANT ASSEMBLY CONSISTS OF ALUMINUM FRONT FRAME AND SABIC IP LEXAN 9034 (VERSIONS ALSO APPROVED: MR10, 9030, 90318, 90316, 90317, 90311, 90314, 90355) OR COVESTRO MAKROLON GP (VERSIONS ALSO APPROVED: SL, AR, 15), APPROVED CC1 PLASTICS IN ACCORDANCE WITH FBC 2606 AND AN APPROVED PLASTIC IN ACCORDANCE WITH FBC 2614. THE ENTIRE DOOR ASSEMBLY INSTALLED IN COMPLIANCE WITH THIS SECTION MEETS THE WIND LOAD REQUIREMENTS OF THE FLORIDA BUILDING CODE AND IS LARGE- AND SMALL-MISSILE IMPACT RESISTANT.

SECTION B-B (IMPACT-RESISTANT GLAZING OPTION)

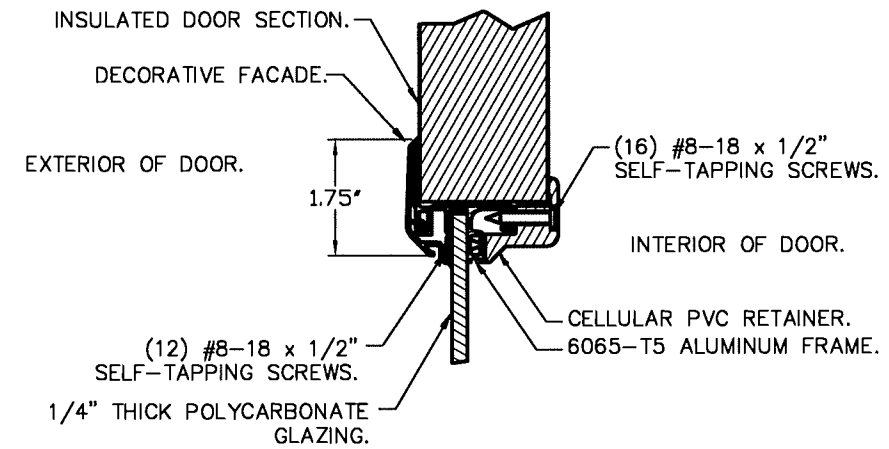

IMPACT-RESISTANT ASSEMBLY DETAILS

DESIGN LOADS: +38.0 P.S.F. & -42.0 P.S.F.

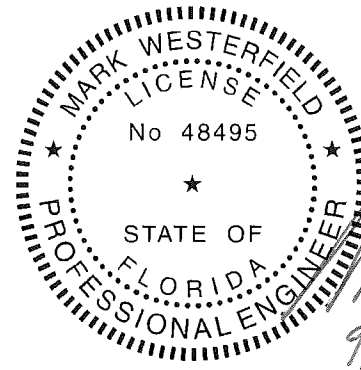

DESIGN ENGINEER:
 MARK WESTERFIELD, P.E.
 FLORIDA LICENSE No. 48495

PRODUCT REVISED
 as complying with the Florida Building Code
 NOA-No. 23-0928.63
 Expiration Date 12/21/2027
 By *[Signature]*
 Miami-Dade Product Control

Unless Stated Otherwise TOLERANCES are
 .0 = ±.031
 .00 = ±.015
 .000 = ±.005
 .0000 = ±.001
 Degrees = ±1/2"
 Unless Stated Otherwise DIMENSIONS ARE IN INCHES.

Clopay CORPORATION
 8585 Duke Boulevard
 Mason, OH 45040 USA
 Tel. No. 513-770-4800
 Fax No. 513-770-4853

MANUFACTURING PRODUCT CODE
 DSIU-1F477

PART NO.: N/A

WINDLOAD RATING
 W6 DP38T

DESCRIPTION: MODERN STEEL 2" INTELICORE +38/-42 PSF TO 18' W			
DRAWN BY: SH	DATE: 01/2017	SCALE: NTS	DWG. SIZE B
CHECKED BY: MW	DATE: 6/20/17	SHEET 2 OF 4	
DWG. NO.: 105188	VER: M-D		

BRAND	MODERN STEEL		COMMERCIAL DOORS	
	FLUSH	GROOVED	FLUSH	GROOVED
CLOPAY	9208, HDPC2	9209, HDPCR2	3728	3729
HOLMES	7208	7209	--	C7R20

SEE SHEET 5 FOR "CANYON RIDGE MODERN SERIES" MODELS.

SHEET: 3 OF 4

REVISIONS					
REV. NO.	ZONE	DATE	ECN NO.	APPVD:	DESCRIPTION
03	-	-	-	-	SEE REVISION HISTORY ON SHEET ONE.

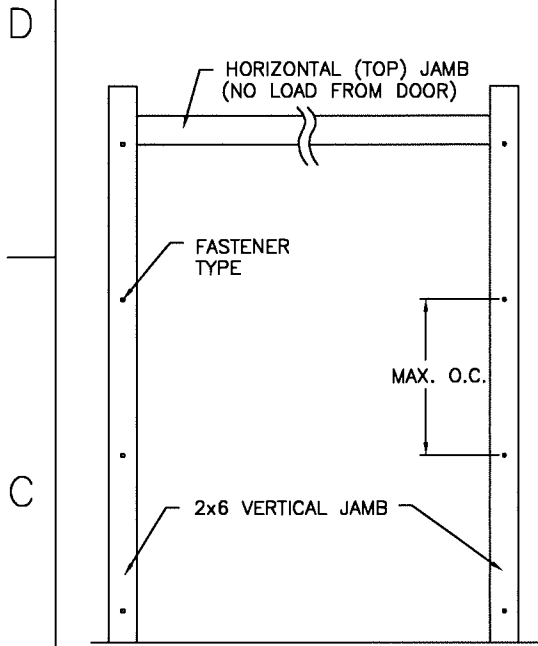

JAMB TO SUPPORTING STRUCTURE ATTACHMENT

NOTES:

1. ALL THE LOAD FROM THE DOOR IS TRANSFERRED TO THE TRACK AND THEN FROM THE TRACK TO THE 2x6 VERTICAL SYP (GRADE #2 OR BETTER) JAMBS. NO LOAD FROM THE DOOR IS TRANSFERRED TO THE HORIZONTAL (TOP) JAMB.
2. EACH VERTICAL JAMB SEES A MAXIMUM DESIGN LOAD OF +342 LB & -378 LB. PER LINEAR FOOT OF JAMB.
3. ALL JAMB FASTENERS MAY BE (BUT ARE NOT REQUIRED TO BE) COUNTERSUNK TO PROVIDE A FLUSH MOUNTING SURFACE.
4. A 1/3 STRESS INCREASE FOR WIND LOAD WAS NOT USED IN THE CALCULATION OF ALLOWABLE LOADS FOR ANCHORS AND FASTENERS FOR STEEL, CONCRETE AND MASONRY.

NOTE: 2x6 WOOD JAMBS ARE NOT REQUIRED WITH CONTINUOUS ANGLE MOUNT TRACK. HOWEVER, IF DESIRED ON STEEL JAMBS OR CONCRETE OR BLOCK WALLS, APPROVED FASTENERS AS DETAILED BELOW SHOULD BE INCREASED IN LENGTH BY 1-1/2" AND INSTALLED DIRECTLY THROUGH THE ANGLE AND 2x6 WOOD JAMBS INTO THE STEEL JAMBS OR CONCRETE OR BLOCK WALLS. ANCHORS CAN BE (BUT ARE NOT REQUIRED TO BE) COUNTERSUNK TO PROVIDE A FLUSH MOUNTING SURFACE. CONTINUOUS ANGLE TRACK CAN BE ANCHORED DIRECTLY TO GROUT REINFORCED BLOCK WALL OR 3,000 PSI MIN. CONCRETE COLUMN OR STEEL JAMBS.

2x6 JAMB TO SUPPORTING STRUCTURE ATTACHMENT
(NOT TO BE USED FOR ATTACHMENT OF TRACK ANGLE TO 2x6 VERTICAL JAMBS)

BUILDING TYPE	FASTENER TYPE	MAXIMUM ON-CENTER DISTANCE BETWEEN FASTENERS*	STEEL WASHERS REQUIRED
HOLLOW CMU BLOCK WALL	1/4" x 1-1/4" MIN. EMBED ULTRACON CONCRETE ANCHOR	4 3/4"	1" O.D.
GROUT-FILLED CMU BLOCK	1/4" x 1-3/4" MIN. EMBED ULTRACON CONCRETE ANCHOR	8"	1" O.D.
2000 PSI MIN. CONCRETE	1/4" x 1-3/4" MIN. EMBED ULTRACON CONCRETE ANCHOR	16 1/2"	1" O.D.
2000 PSI MIN. CONCRETE	1/4" x 1-3/4" MIN. EMBED TAPCON CONCRETE ANCHOR	15 1/2"	1" O.D.
2000 PSI MIN. CONCRETE	3/8" x 1-3/4" MIN. EMBED WEJ-IT ANKR TITE SLEEVE ANCHOR	14 1/2"	INCLUDED
4000 PSI MIN. CONCRETE	3/8" x 1-3/4" MIN. EMBED WEJ-IT ANKR TITE SLEEVE ANCHOR	24"	INCLUDED
WOOD FRAME (SYP 0.55 SG)	1/2" x 3" LAG SCREW (ASTM A307, GRADE A) 1-5/8" EMBED INTO STRUCTURE	15 3/4"	1" O.D.
14GA STEEL (0.060" MIN.)	1/4"-14 x 1" ITW BUILDEX TEKS SELF-DRILLING FASTENER	7 1/2"	1" O.D.
12GA STEEL (0.105" MIN.)	1/4"-14 x 1" ITW BUILDEX TEKS SELF-DRILLING FASTENER	11 3/4"	1" O.D.
1/8" STEEL	1/4"-14 x 1" ITW BUILDEX TEKS SELF-DRILLING FASTENER	13 3/4"	1" O.D.

* FIRST (BOTTOM) ANCHOR STARTING AT NO MORE THAN HALF OF THE MAXIMUM ON-CENTER DISTANCE. HIGHEST ANCHOR INSTALLED AT LEAST AS HIGH AS THE DOOR OPENING.
CLOPAY DOES NOT SUPPLY JAMB ATTACHMENT FASTENERS.
MINIMUM DISTANCE BETWEEN CENTER OF ANCHOR AND EDGE OF CONCRETE: 2-1/2", EXCLUDING STUCCO THICKNESS. EXCEPTION FOR TAPCON --- MINIMUM EDGE DISTANCE FOR TAPCON FASTENER IS 1-1/4", EXCLUDING STUCCO THICKNESS.

0.016" (27 GA.) MIN. STEEL G-40 GALV. EXTERIOR SKIN (31.2 KSI MIN. YIELD STRENGTH) WITH BAKED-ON PRIMER AND A BAKED-ON POLYESTER PAINTED TOP COAT.

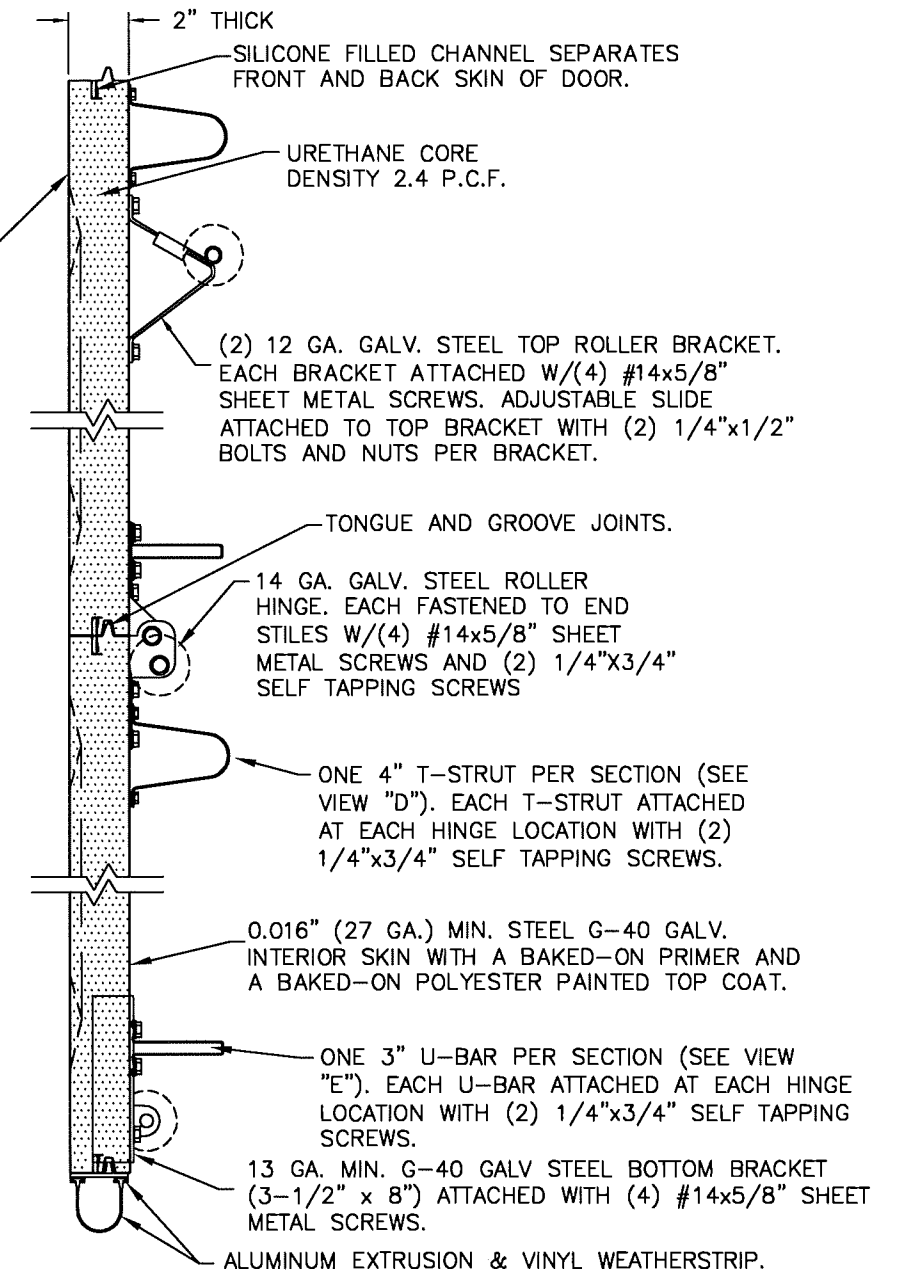
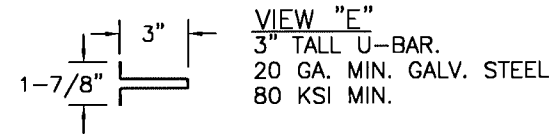
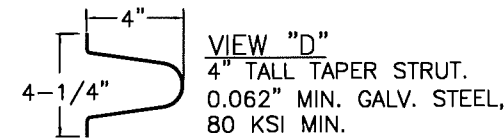

SECTION A-A (SIDE VIEW)

DESIGN LOADS: +38.0 P.S.F. & -42.0 P.S.F.

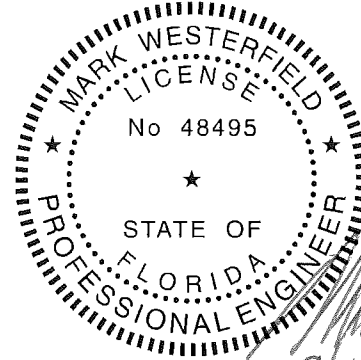

DESIGN ENGINEER:
MARK WESTERFIELD, P.E.
FLORIDA LICENSE No. 48495

PRODUCT REVISED
as complying with the Florida Building Code
NOA-No. 23-0928.63
Expiration Date 12/21/2027
By *[Signature]*
Miami-Dade Product Control

Unless Stated Otherwise TOLERANCES are
.0 = ±.031
.00 = ±.015
.000 = ±.005
.0000 = ±.001
Degrees = ±1/2"

Unless Stated Otherwise DIMENSIONS ARE IN INCHES.



8585 Duke Boulevard
Mason, OH 45040 USA
Tel. No. 513-770-4800
Fax No. 513-770-4853

MANUFACTURING PRODUCT CODE
DSIU-1F477

PART NO.: N/A

WINDLOAD RATING
W6 DP38T

DESCRIPTION: MODERN STEEL 2" INTELLICORE +38/-42 PSF TO 18' W

DRAWN BY: SH DATE: 01/2017 SCALE: NTS DWG. B

CHECKED BY: MW DATE: 6/20/17 SHEET 3 OF 4 SIZE B

DWG. NO.: 105188 VER: M-D

BRAND	MODERN STEEL		COMMERCIAL DOORS	
	FLUSH	GROOVED	FLUSH	GROOVED
CLOPAY	9208, HDPC2	9209, HDPCR2	3728	3729
HOLMES	7208	7209	--	C7R20

SEE SHEET 5 FOR "CANYON RIDGE MODERN SERIES" MODELS.

SHEET: 4 OF 4

REVISIONS					
REV. NO.	ZONE:	DATE:	ECN NO.	APPVD:	DESCRIPTION
03	-	-	-	-	SEE REVISION HISTORY ON SHEET ONE.

2" TRACK CONFIGURATION.

NOTE DOUBLE TRACK HEADROOM, HI-LIFT TRACK, FOLLOW-THE-ROOF TRACK, AND VERTICAL LIFT TRACK ARE AVAILABLE OPTIONS. TRACK CONFIGURATION ABOVE THE DOOR OPENING DOES NOT AFFECT THE WIND LOAD RATING.

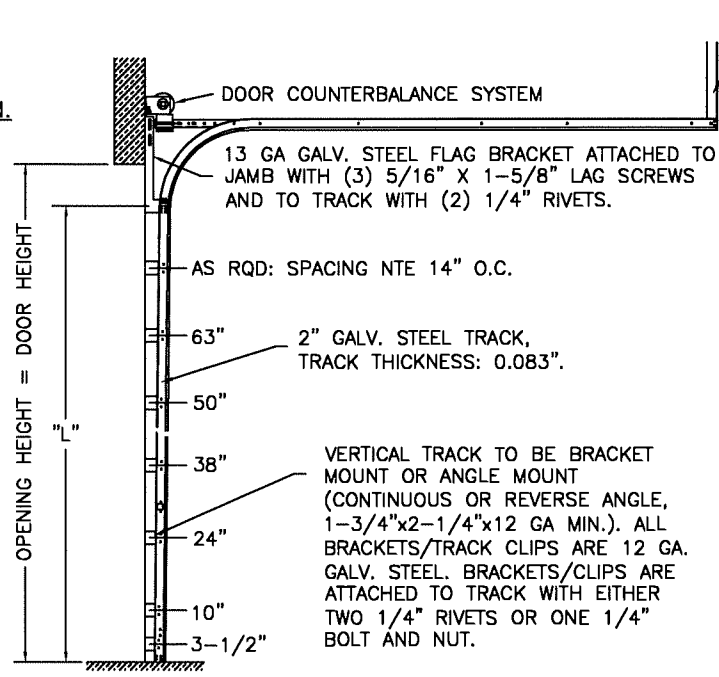

DOOR HEIGHT	"L"
6'-6"	70"
7'-0"	76"
7'-6"	82"
8'-0"	88"
8'-6"	94"
9'-0"	100"
9'-6"	106"
10'-0"	112"
10'-6"	118"
11'-0"	124"
11'-6"	130"
12'-0"	136"
12'-6"	142"
13'-0"	148"
13'-6"	154"
14'-0"	160"
14'-6"	166"
15'-0"	172"
15'-6"	178"
16'-0"	184"

HORIZONTAL TRACK SUPPORT BY DOOR INSTALLER (TO SUIT).

JAMB CONFIGURATION FOR 2" TRACK.

BRACKET MOUNT JAMB CONFIGURATION

1" DOOR OVERLAP (EACH SIDE)

2-1/2" x 12 GA. GALV. STEEL TRACK BRACKETS FASTENED TO WOOD JAMBS WITH 5/16" x 1-5/8" LAG SCREWS. NOT TO EXCEED 14" ON-CENTER.

OPTIONAL STOP MOULDING BY INSTALLER (TO SUIT).

16 GA GALV. 5-3/4" x 2-1/8" x 3/8" STEEL DOUBLE-END-STILE FASTENED WITH (1) #8 X 1/2" WAFER SCREW.

7/16" I.D. ROUND PUSH NUT FASTENER.

14 GA. GALV. STEEL CENTER HINGE FASTENED TO SECTION W/(4) EACH #14x5/8" SHEET METAL SCREWS.

14 GA. GALV. STEEL ROLLER HINGES FASTENED TO END STILES W/(4) EACH #14x5/8" SHEET METAL SCREWS AND (2) 1/4" SELF TAPPING SCREWS PER END HINGE.

2" DIA. 7-1/2" LONG STEM, 10 BALL STEEL ROLLER WITH STEEL OR NYLON TIRE.

2" GALV. STEEL TRACK FASTENED TO 12 GA. GALV. STEEL TRACK BRACKETS WITH EITHER (2) 1/4" DIA. RIVETS OR (1) 1/4" x 5/8" BOLT & NUT PER TRACK BRACKET.

SECTION C-C

PREPARATION OF JAMBS BY OTHERS.

ANGLE MOUNT JAMB CONFIGURATION

2x6 SYP JAMB (IF PRESENT; SEE JAMB NOTES ON SHEET 3).

VERTICAL TRACK TO BE CONTINUOUS OR REVERSE ANGLE. 12 GA. TRACK CLIPS ATTACHED TO WALL ANGLE WITH TWO 1/4" RIVETS PER CLIP. TRACK CLIPS ARE ATTACHED TO TRACK WITH ONE 1/4" BOLT AND NUT. FOR WOOD JAMBS: ONE 5/16" X 1-5/8" LAG SCREW AT EACH TRACK CLIP LOCATION. ALSO AT LEAST TWO LAG SCREWS LOCATED ABOVE VERTICAL/HORIZONTAL TRACK JUNCTION.

3" TRACK CONFIGURATION.

NOTE DOUBLE TRACK HEADROOM, HI-LIFT TRACK, FOLLOW-THE-ROOF TRACK, AND VERTICAL LIFT TRACK ARE AVAILABLE OPTIONS. TRACK CONFIGURATION ABOVE THE DOOR OPENING DOES NOT AFFECT THE WIND LOAD RATING.

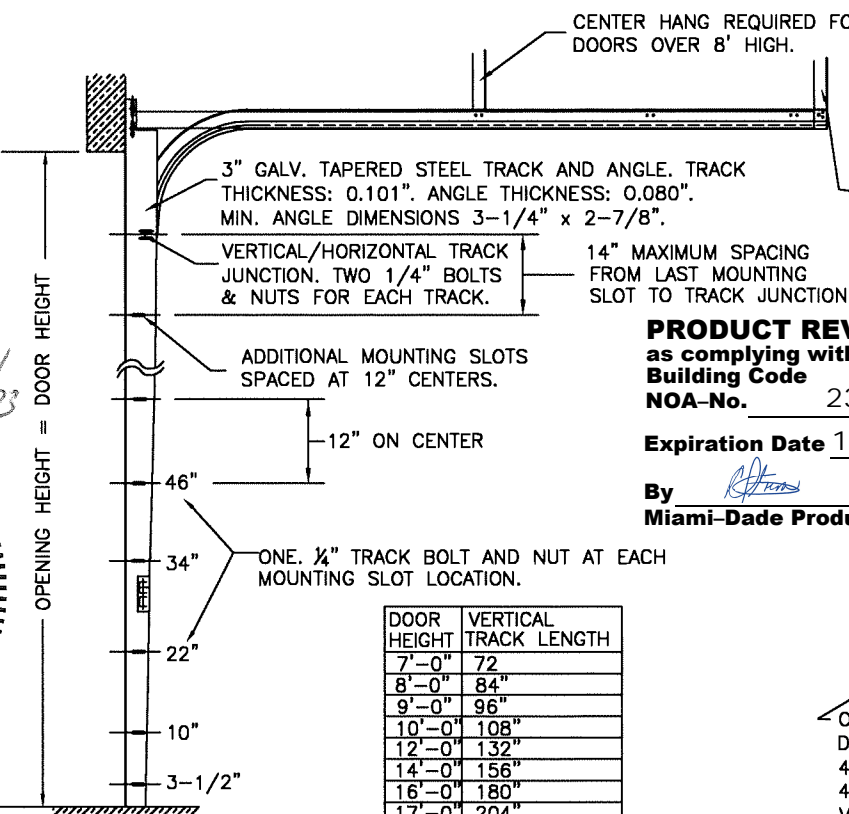

DOOR HEIGHT	VERTICAL TRACK LENGTH
7'-0"	72"
8'-0"	84"
9'-0"	96"
10'-0"	108"
12'-0"	132"
14'-0"	156"
16'-0"	180"
17'-0"	204"
18'-0"	228"

JAMB CONFIGURATION FOR 3" TRACK.

1" DOOR OVERLAP (EACH SIDE)

2x6 SYP JAMB (IF PRESENT; SEE JAMB NOTES ON SHEET 3).

3-1/4" x 2-7/8" MIN. x 0.080" TAPERED ANGLE. SEE LAG BOLT MOUNTING AT TRACK CONFIGURATION BELOW.

0.101" THICK 3" GALV. STEEL TRACK FASTENED TO TAPERED ANGLE. TRACK ATTACHED TO TAPERED ANGLE WITH ONE 1/4"x5/8" BOLT & NUT AT EACH MOUNTING SLOT.

OPTIONAL STOP MOULDING BY DOOR INSTALLER (TO SUIT).

16 GA GALV. 5-3/4" 2-1/8" x 3/8" STEEL DOUBLE-END-STILE FASTENED WITH (1) #8 X 1/2" WAFER SCREW.

7/16" I.D. ROUND PUSH NUT FASTENER.

14 GA. GALV. STEEL CENTER HINGE FASTENED TO SECTION W/(4) EACH #14x5/8" SHEET METAL SCREWS.

14 GA. GALV. STEEL ROLLER HINGES FASTENED TO END STILES W/(4) EACH #14x5/8" SHEET METAL SCREWS AND (2) 1/4" SELF TAPPING SCREWS PER END HINGE.

3" DIA. 8-1/2" LONG STEM BALL BEARING STEEL ROLLER.

SECTION C-C

PREPARATION OF JAMBS BY OTHERS.

DESIGN LOADS: +38.0 P.S.F. & -42.0 P.S.F.

Unless Stated Otherwise TOLERANCES are

.0 = ±.031

.00 = ±.015

.000 = ±.005

.0000 = ±.001

Degrees = ±1/2°

Unless Stated Otherwise DIMENSIONS ARE IN INCHES.

Glopay CORPORATION

8585 Duke Boulevard
Mason, OH 45040 USA
Tel. No. 513-770-4800
Fax No. 513-770-4853

MANUFACTURING PRODUCT CODE
DSIU-1F477

PART NO.: N/A

WINDLOAD RATING
W6 DP38T

DESCRIPTION: MODERN STEEL 2" INTELICORE +38/-42 PSF TO 18' W

DRAWN BY: SH DATE: 01/2017 SCALE: NTS DWG. B

CHECKED BY: MW DATE: 6/20/17 SHEET 4 OF 4

DWG. NO.: 105188 VER: M-D

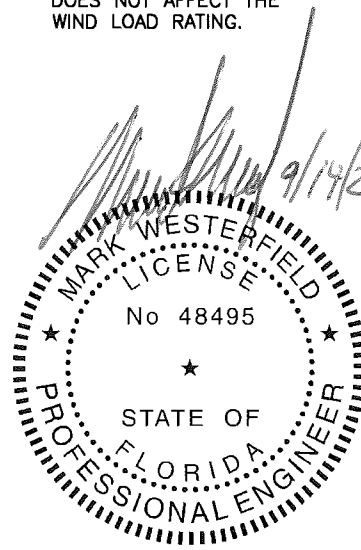

DESIGN ENGINEER:
MARK WESTERFIELD, P.E.
FLORIDA LICENSE No. 48495