



DEPARTMENT OF REGULATORY AND ECONOMIC RESOURCES (RER)
 BOARD AND CODE ADMINISTRATION DIVISION
NOTICE OF ACCEPTANCE (NOA)

MIAMI-DADE COUNTY
 PRODUCT CONTROL SECTION
 11805 SW 26 Street, Room 208
 Miami, Florida 33175-2474
 T (786) 315-2590 F (786) 315-2599
www.miamidade.gov/economy

Clopay Corporation
8585 Duke Boulevard
Mason, OH 45040

SCOPE:

This NOA is being issued under the applicable rules and regulations governing the use of construction materials. The documentation submitted has been reviewed and accepted by Miami-Dade County RER-Product Control Section to be used in Miami-Dade County and other areas where allowed by the Authority Having Jurisdiction (AHJ).

This NOA shall not be valid after the expiration date stated below. The Miami-Dade County Product Control Section (In Miami-Dade County) and/or the AHJ (in areas other than Miami-Dade County) reserve the right to have this product or material tested for quality assurance purposes. If this product or material fails to perform in the accepted manner, the manufacturer will incur the expense of such testing and the AHJ may immediately revoke, modify, or suspend the use of such product or material within their jurisdiction. RER reserves the right to revoke this acceptance, if it is determined by Miami-Dade County Product Control Section that this product or material fails to meet the requirements of the applicable building code.

This product is approved as described herein and has been designed to comply with the Florida Building Code, including the High Velocity Hurricane Zone.

DESCRIPTION: 2in Steel Pan W6 DP36 Sectional Garage Door up to 18ft-2in Wide w/ Optional Impact Resistant Lites

APPROVAL DOCUMENT: Drawing No. **104761**, titled “2” Steel Pan Doors 18’-2”, sheets 1 through 3 of 3, dated 11/08/2012, with revision **07** dated 09/07/2023, prepared by Clopay Corporation, signed, and sealed by Scott Hamilton, P.E., bearing the Miami-Dade County Product Control revision stamp with the Notice of Acceptance number and expiration date by the Miami-Dade County Product Control Section.

MISSILE IMPACT RATING: Large and Small Missile Impact Resistant

LABELING: A permanent label with the manufacturer’s name or logo, manufacturing address, model number, the positive and negative design pressure rating, indicate impact rated if applicable, installation instruction drawing reference number, approval number (NOA), the applicable test standards, and the statement reading ‘Miami-Dade County Product Control Approved’ is to be located on the door’s side track, bottom angle, or inner surface of a panel.

RENEWAL of this NOA shall be considered after a renewal application has been filed and there has been no change in the applicable building code negatively affecting the performance of this product.

TERMINATION of this NOA will occur after the expiration date or if there has been a revision or change in the materials, use, and/or manufacture of the product or process. Misuse of this NOA as an endorsement of any product, for sales, advertising or any other purposes shall automatically terminate this NOA. Failure to comply with any section of this NOA shall be cause for termination and removal of NOA.

ADVERTISEMENT: The NOA number preceded by the words Miami-Dade County, Florida, and followed by the expiration date may be displayed in advertising literature. If any portion of the NOA is displayed, then it shall be done in its entirety.

INSPECTION: A copy of this entire NOA shall be provided to the user by the manufacturer or its distributors and shall be available for inspection at the job site at the request of the Building Official.

This NOA **revises NOA # 23-0314.02** and consists of this page 1 and evidence pages E-1, E-2, E-3, E-4, and E-5, as well as approval document mentioned above.

The submitted documentation was reviewed by **Carlos M. Utrera, P.E.**



NOA-No 23-0928.80
Expiration Date: April 11, 2028
Approval Date: November 22, 2023
Page 1

Clopay Corporation

NOTICE OF ACCEPTANCE: EVIDENCE SUBMITTED

1. EVIDENCE SUBMITTED UNDER PREVIOUS NOA's

A. DRAWINGS “Submitted under NOA # 15-0225.11”

1. Drawing No. **104761**, titled “2” Steel Pan Doors 18’-2”, sheets 1 through 3 of 3, dated 11/08/2012, with revision **03** dated 2/2015, prepared by Clopay Building Products Company, signed and sealed by Scott Hamilton, P.E.

B. TESTS “Submitted under NOA # 12-1205.08”

1. Test reports on 1) Uniform Static Air Pressure Test, Loading per FBC TAS 202-94
2) Large Missile Impact Test per FBC, TAS 201-94
3) Cyclic Wind Pressure Loading per FBC, TAS 203-94
4) Forced Entry Test, per FBC, TAS 202-94
5) Tensile Test per ASTM E8
along with marked-up drawings and installation diagram of 18’-2”x 8’, 25ga steel garage door Model 73W6 with windows, prepared by American Test Lab, Inc., Test Report No. **ATLNC 1113.01-12R**, dated 02/18/2013, signed and sealed by David W. Johnson, P.E.
2. Test report on Salt Spray per ASTM B117 of painted G40 galvanized coated panels, prepared by Stork Materials Technology, Test Report No. **30160-04-63365**, dated 01/26/2005, signed by John D. Lee, P.E.

C. CALCULATIONS “Submitted under NOA # 12-1205.08”

1. Jamb anchor calculations prepared by Clopay Building Products Company, dated 11/30/2012, signed and sealed by Scott Hamilton, P.E.

D. QUALITY ASSURANCE

1. Miami-Dade Department of Regulatory and Economic Resources (RER).

E. MATERIAL CERTIFICATIONS

1. Notice of Acceptance No. **13-0717.01** issued to SABIC Innovative Plastics for their Lexan Polycarbonate Sheet Products, approved on 11/28/2013, expiring on 07/17/2018.

F. STATEMENTS “Submitted under NOA # 15-0225.11”

1. Statement letter of code conformance with the 2010 and the 5th edition (2014) FBC issued by Clopay Building Products Company, dated 02/18/2015, signed and sealed by Scott Hamilton, P.E.
2. Statement letters of code conformance to 2010 FBC and no financial interest, issued by Clopay Building Products Company, dated 11/30/2012, signed and sealed by Scott Hamilton, P.E. “Submitted under NOA # 12-1205.08”



Carlos M. Utrera, P.E.
Product Control Examiner
NOA-No 23-0928.80
Expiration Date: April 11, 2028
Approval Date: November 22, 2023

Clopay Corporation

NOTICE OF ACCEPTANCE: EVIDENCE SUBMITTED

2. EVIDENCE SUBMITTED UNDER PREVIOUS NOA # 15-0225.11

A. DRAWINGS

1. Drawing No. **104761**, titled "2" Steel Pan Doors 18'-2", sheets 1 through 3 of 3, dated 11/08/2012, with revision **04** dated 7/2017, prepared by Clopay Building Products Company, signed, and sealed by Scott Hamilton, P.E.

B. TESTS

1. None.

C. CALCULATIONS

1. None.

D. QUALITY ASSURANCE

1. Miami-Dade Department of Regulatory and Economic Resources (RER)

E. MATERIAL CERTIFICATIONS

1. Notice of Acceptance No. **15-0915.08** issued to SABIC Innovative Plastics, US LLC for their Lexan Polycarbonate Sheet Products, approved on 12/10/2015, expiring on 07/17/2018.

F. STATEMENTS

1. Statement letter of code conformance to **6th Edition (2017) FBC**, issued by Clopay Building Products Company, dated 10/04/2017, signed, and sealed by Scott Hamilton, P.E.
2. Statement letter of no financial interest, issued by Clopay Building Products Company, dated 10/04/2017, signed, and sealed by Scott Hamilton, P.E.



Carlos M. Utrera, P.E.
Product Control Examiner
NOA-No 23-0928.80
Expiration Date: April 11, 2028
Approval Date: November 22, 2023

Clopay Corporation

NOTICE OF ACCEPTANCE: EVIDENCE SUBMITTED

3. EVIDENCE SUBMITTED UNDER NOA # 17-1016.15

A. DRAWINGS

1. Drawing No. **104761**, titled "2" Steel Pan Doors 18'-2", sheets 1 through 3 of 3, dated 11/08/2012, with revision **05** dated 08/26/2020, prepared by Clopay Corporation, dated 09/16/2020, signed, and sealed by Scott Hamilton, P.E.

B. TESTS

1. None.

C. CALCULATIONS

1. None.

E. QUALITY ASSURANCE

1. Miami-Dade Department of Regulatory and Economic Resources (RER).

F. MATERIAL CERTIFICATIONS

1. None.

G. STATEMENTS

1. Statement letters of code conformance to **6th Edition (2017) and 7th Edition (2020) FBC**, issued by Clopay Corporation, dated 09/15/2020, signed, and sealed by Scott Hamilton, P.E.
2. Certificate of amendment changing the company name from Clopay Building Products Company, Inc. to Clopay Corporation, issued by the State of Delaware, dated 08/27/2019.



Carlos M. Utrera, P.E.
Product Control Examiner
NOA-No 23-0928.80
Expiration Date: April 11, 2028
Approval Date: November 22, 2023

Clopay Corporation

NOTICE OF ACCEPTANCE: EVIDENCE SUBMITTED

4. EVIDENCE SUBMITTED UNDER NOA # 20-0922.17

A. DRAWINGS

1. Drawing No. **104761**, titled "2" Steel Pan Doors 18'-2", sheets 1 through 3 of 3, dated 11/08/2012, with revision **06** dated 03/02/2023, prepared by Clopay Corporation, signed, and sealed by Scott Hamilton, P.E.

B. TESTS

- 1 Test reports on
 - 1) Uniform Static Air Pressure Test, Loading per FBC TAS 202-94
 - 2) Large Missile Impact Test per FBC, TAS 201-94
 - 3) Cyclic Wind Pressure Loading per FBC, TAS 203-94
 - 4) Forced Entry Test, per FBC, TAS 202-94
 - 5) Tensile Test per ASTM E8along with marked-up drawings and installation diagram of 18'-2"x 8', 24ga steel garage door Model 94W6 with windows, prepared by American Test Lab, Inc., Test Report No. ATLNC **0103.02-23**, dated 02/28/2023, signed, and sealed by David W. Johnson, P.E.

C. CALCULATIONS

1. Jamb anchor calculations prepared by Clopay Building Products Company, dated 03/02/2023, signed, and sealed by Scott Hamilton, P.E.

D. QUALITY ASSURANCE

1. Miami-Dade Department of Regulatory and Economic Resources (RER).

E. MATERIAL CERTIFICATIONS

1. Notice of Acceptance NOA # **21-1109.01**, issued to SABIC Innovative Plastic US LLC for its Lexan Polycarbonate Sheet Products, approved on 04/07/2022 and expiring on 04/01/2026.

F. STATEMENTS

1. Statement letter of code conformance to **7th Edition (2020) of the FBC**, issued by Clopay Corporation, dated 03/02/2023, signed, and sealed by Scott Hamilton, P.E.
2. Statement letter of no financial interest, issued by Clopay Corporation, dated 03/02/2023, signed, and sealed by Scott Hamilton, P.E.



Carlos M. Utrera, P.E.
Product Control Examiner
NOA-No 23-0928.80
Expiration Date: April 11, 2028
Approval Date: November 22, 2023

Clopay Corporation

NOTICE OF ACCEPTANCE: EVIDENCE SUBMITTED

5. EVIDENCE SUBMITTED UNDER NOA # 23-0314.02 AND NEW

A. DRAWINGS

1. Drawing No. **104761**, titled "2" Steel Pan Doors 18'-2", sheets 1 through 3 of 3, dated 11/08/2012, with revision **07** dated 09/07/2023, prepared by Clopay Corporation, signed, and sealed by Scott Hamilton, P.E.

B. TESTS

1. None.

C. CALCULATIONS

1. None.

D. QUALITY ASSURANCE

1. Miami-Dade Department of Regulatory and Economic Resources (RER).

E. MATERIAL CERTIFICATIONS

1. None.

F. STATEMENTS

1. Statement letters of code conformance to **7th Edition (2020) and 8th Edition (2023) FBC**, issued by Clopay Corporation, dated 09/15/2023, signed, and sealed by Scott Hamilton, P.E.



Carlos M. Utrera, P.E.
Product Control Examiner
NOA-No 23-0928.80
Expiration Date: April 11, 2028
Approval Date: November 22, 2023

MODELS	24 GA SHORT	24 GA FLUSH
CLOPAY	84A, 94	98
HOLMES	48, 48B	--
IDEAL	4RST	4F

ONE INTERMEDIATE STILE BETWEEN EACH EMBOSS LOCATION. ATTACHED W/ TOG-L-LOC (TOP & BTM) AND URETHANE ADHESIVE (ALONG CENTER).

SHEET:
1 OF 3

REVISIONS					
REV. NO.	ZONE:	DATE:	ECN NO.	APPVD:	DESCRIPTION
05	-	8/26/20	-	SH	UPDATED TITLE BLOCK AND CODE COMPLIANCE STATEMENT TO 7TH
06	-	3/2/23	-	SH	UPDATED FASTENERS AND STEEL CALL-OUT.
07	-	9/7/23	-	JDW	UPDATED CODE COMPLIANCE STATEMENT TO ADD 8TH EDITION FBC

IMPACT-RESISTANT CONSTRUCTION:
SOLID DOORS (NO GLAZING) OR DOORS WITH OPTIONAL IMPACT-RESISTANT GLAZING ARE IMPACT-RESISTANT. OPTIONAL INJECTION-MOLDED POLYCARBONATE FRONT FRAME AND GLAZING IS GE LEXAN SLX2432T, AN APPROVED CC2 PLASTIC IN ACCORDANCE WITH IBC/FBC 2606. THE ENTIRE DOOR ASSEMBLY INSTALLED IN COMPLIANCE WITH THIS SECTION MEETS THE WIND LOAD REQUIREMENTS OF THE FLORIDA BUILDING CODE AND INTERNATIONAL BUILDING CODE AND IS LARGE- AND SMALL-MISSILE IMPACT RESISTANT.

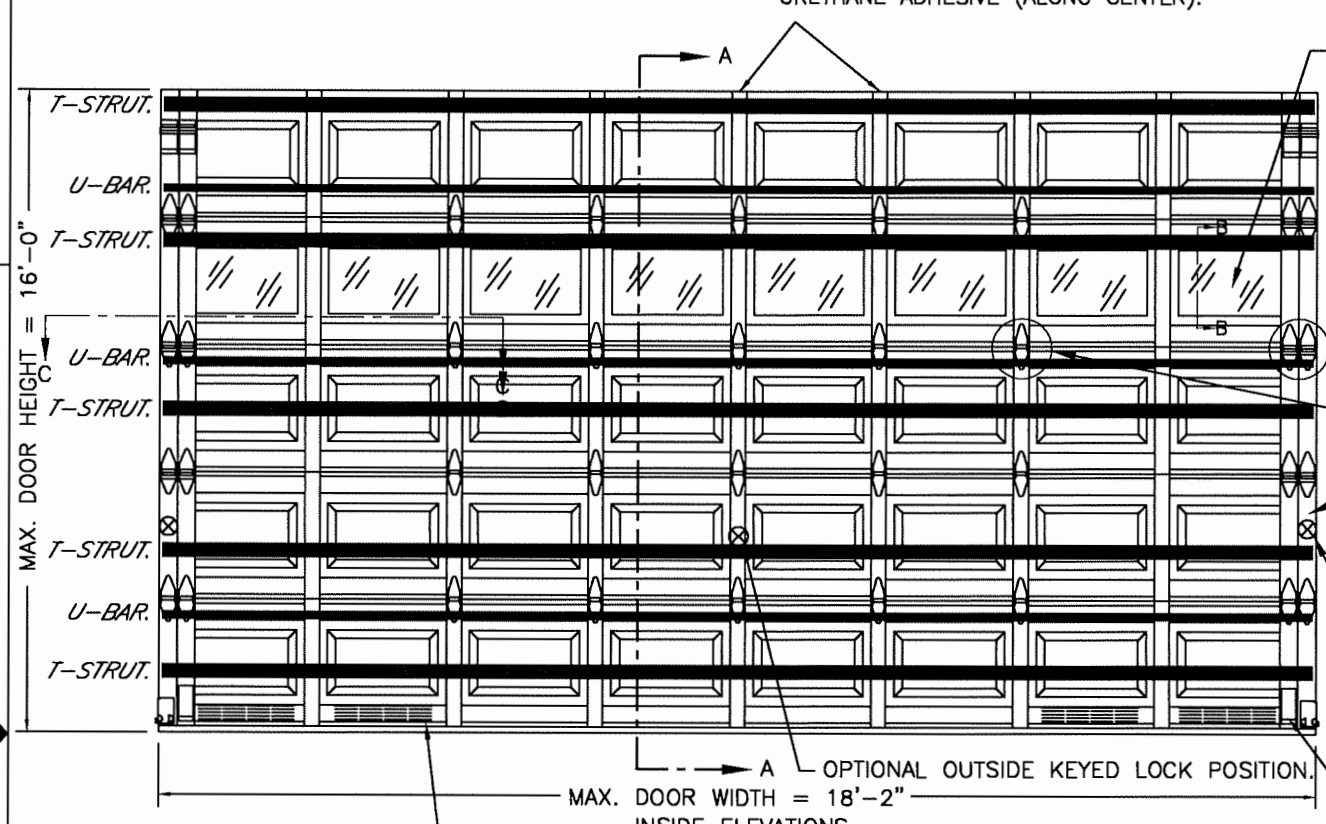

OPTIONAL ROW OF IMPACT-RESISTANT GLAZING. MAX. GLAZING SIZE IS 18-1/2" x 11". GLAZING IS INJECTION MOLDED GE LEXAN SLX2432T, AN APPROVED CC2 PLASTIC IN ACCORDANCE WITH IBC/FBC 2606. SEE SECTION B-B FOR ASSEMBLY DETAILS. (GLAZING SHOWN IN INTERMEDIATE SECTION.)

VIEW "B" (SEE SHEET TWO).
VIEW "C" (SEE SHEET TWO).
16 GA. END STILES ATTACHED TO DOOR SKIN WITH PATENTED TOG-L-LOC SYSTEM (TOP, BOTTOM & CENTER). ATTACHED TO TOP AND BOTTOM RAIL WITH PATENTED TOG-L-LOC SYSTEM.
TWO POINT LOCKING INTO TRACK.
(2) LHR TOP BRACKETS USED AS INNER BOTTOM BRACKET.
(1) 3-IN ROLLER CARRIER (P/N 0120394) USED WITH 3" TRACK.

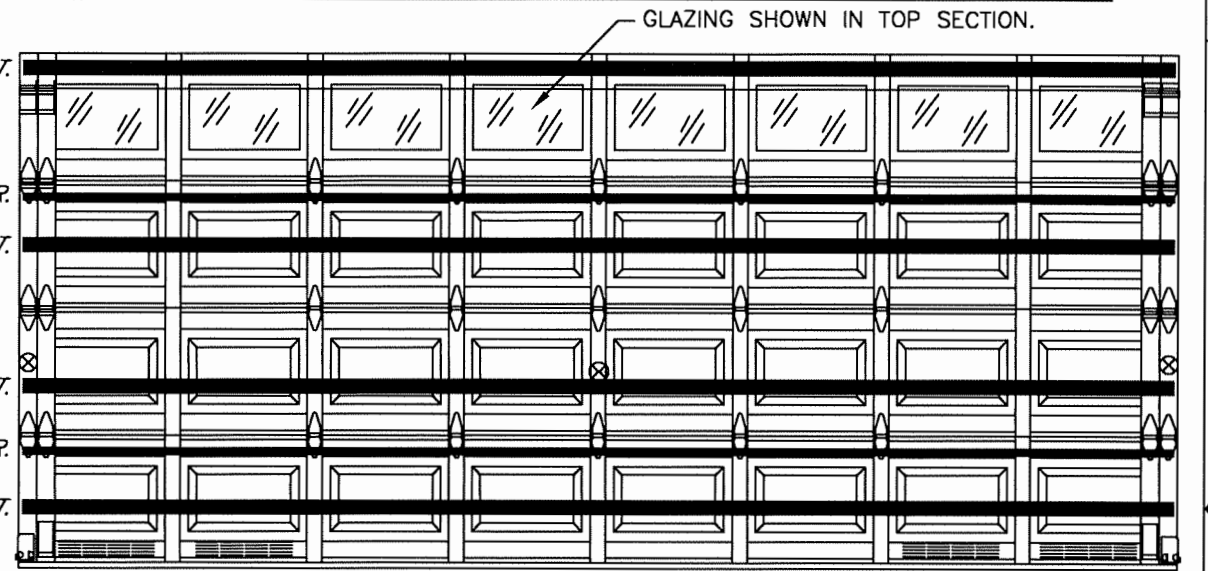

DOOR HEIGHT	# OF SECTIONS
UP TO 7'0"	4
7'3" TO 8'9"	5
9'0" TO 10'6"	6
10'9" TO 12'3"	7
12'6" TO 14'0"	8
14'3" TO 15'9"	9
16'0"	10

MAX SECTION HEIGHT: 21"

LOCATION OF OPTIONAL VENTS. TOTAL VENT OPENINGS: 60 IN² PER VEHICLE.

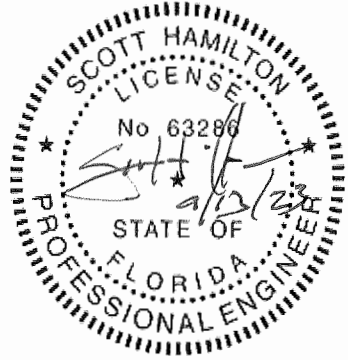
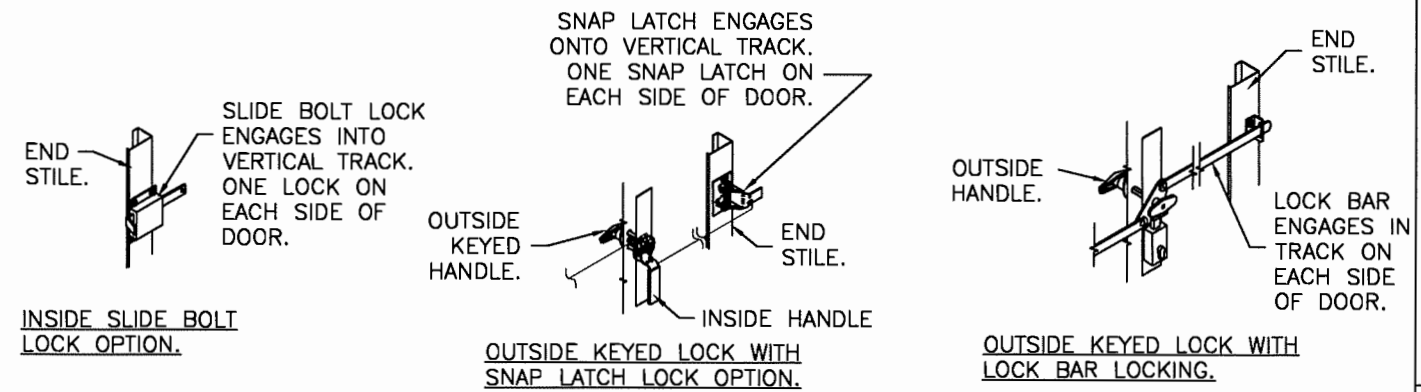
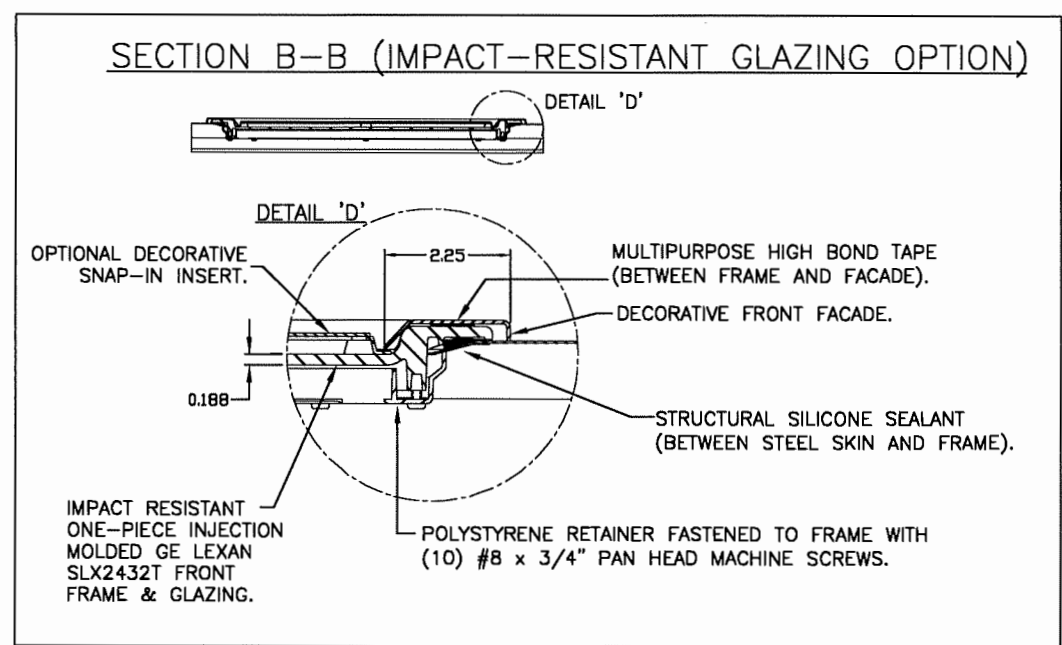

DESIGN ENGINEER:
SCOTT HAMILTON, P.E.
FLORIDA LICENSE No. 63286

PRODUCT REVISED
as complying with the Florida Building Code
NOA-No. 23-0928.80
Expiration Date 04/11/2028
By *[Signature]*
Miami-Dade Product Control

DESIGN LOADS: +36.0 P.S.F. & -42.0 P.S.F.
Unless Stated Otherwise
TOLERANCES are
.0 = ±.031
.00 = ±.015
.000 = ±.005
.0000 = ±.001
Degrees = ±1/2"
Unless Stated Otherwise
DIMENSIONS ARE IN INCHES.

8585 Duke Boulevard Mason, OH 45040 USA Tel. No. 513-770-4800 Fax No. 513-770-4853		PART NO.: N/A	
Glopay CORPORATION		WINDLOAD RATING W6 DP36	
DESCRIPTION: 2" STEEL PAN DOORS 18'2" (SEE TABLE FOR MODELS)			
DRAWN BY: SH	DATE: 11/6/12	SCALE: NTS	DWG. B
CHECKED BY: SH	DATE: 11/8/12	SHEET 1 OF 3	SIZE B
DWG. NO.: 104761		VER: MD	

MODELS	24 GA SHORT	24 GA FLUSH
CLOPAY	84A, 94	98
HOLMES	48, 48B	--
IDEAL	4RST	4F

SHEET:
2 OF 3

REVISIONS					
REV. NO.	ZONE:	DATE:	ECN NO.	APPVD:	DESCRIPTION
07	-	-	-	-	SEE REVISION HISTORY ON SHEET ONE.

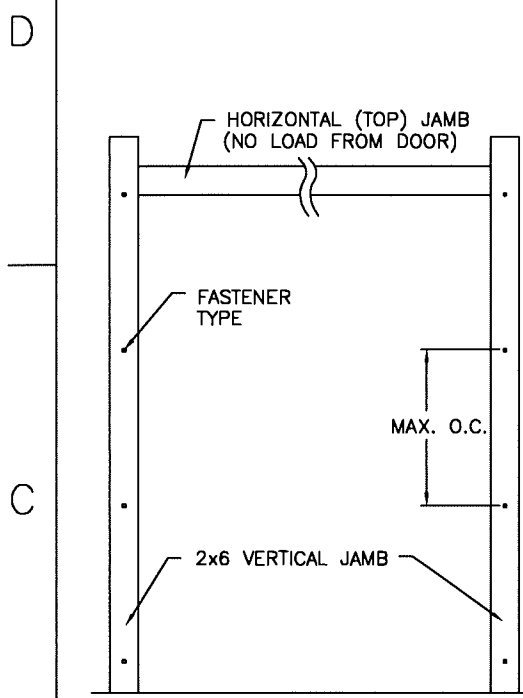

JAMB TO SUPPORTING STRUCTURE ATTACHMENT

NOTES:

1. ALL THE LOAD FROM THE DOOR IS TRANSFERRED TO THE TRACK AND THEN FROM THE TRACK TO THE 2x6 VERTICAL SYP (GRADE #2 OR BETTER) JAMBS. NO LOAD FROM THE DOOR IS TRANSFERRED TO THE HORIZONTAL (TOP) JAMB.
2. EACH VERTICAL JAMB SEES A MAXIMUM DESIGN LOAD OF +342 LB & -378 LB. PER LINEAR FOOT OF JAMB.
3. ALL JAMB FASTENERS MAY BE (BUT ARE NOT REQUIRED TO BE) COUNTERSUNK TO PROVIDE A FLUSH MOUNTING SURFACE.
4. A 1/3 STRESS INCREASE FOR WIND LOAD WAS NOT USED IN THE CALCULATION OF ALLOWABLE LOADS FOR ANCHORS AND FASTENERS FOR STEEL, CONCRETE AND MASONRY.

WOOD FRAME BUILDINGS

STUD WALLS OF DOOR OPENING SHALL BE FRAMED SOLID BY NOT LESS THAN (3) 2x6 PRESSURE TREATED SYP (GRADE #2 OR BETTER) WOOD STUDS OF A STRESS GRADE NOT LESS THAN 1200 PSI NOMINAL EXTREME FIBER STRESS IN BENDING (F_b) FOR DOORS UP TO 8'0" HIGH OR (4) 2x6 PRESSURE TREATED SYP (GRADE #2 OR BETTER) WOOD STUDS OF A STRESS GRADE NOT LESS THAN 1200 PSI NOMINAL EXTREME FIBER STRESS IN BENDING (F_b) FOR DOORS UP TO 16'0" HIGH. STUD WALLS TO BE CONTINUOUS FROM FOOTING TO TIE BEAMS.

BLOCK WALL OR CONCRETE

2x6 SYP (GRADE #2 OR BETTER) WOOD JAMB SHALL BE ANCHORED TO GROUT REINFORCED BLOCK WALL OR CONCRETE COLUMN. BLOCK WALL CELLS SHALL BE FILLED WITH CONCRETE AND REINFORCED WITH REINFORCING BARS EXTENDING INTO THE FOOTING AND INTO TIE BEAMS. ALL BARS SHALL BE CONTINUOUS FROM THE TIE BEAMS TO FOOTING PER BLOCK WALL OR CONCRETE COLUMN. BLOCK WALLS AND CONCRETE COLUMNS TO BE DESIGNED BY THE BUILDING ENGINEER OR ARCHITECT OF RECORD AND IN ACCORDANCE WITH THE FLORIDA BUILDING CODE.

2x6 JAMB TO SUPPORTING STRUCTURE ATTACHMENT
(NOT TO BE USED FOR ATTACHMENT OF TRACK ANGLE TO 2x6 VERTICAL JAMBS OR SUPPORTING STRUCTURE)

BUILDING TYPE	FASTENER TYPE	MAXIMUM ON-CENTER DISTANCE BETWEEN FASTENERS*	STEEL WASHERS REQUIRED?
BLOCK WALL	1/4" X 1-1/4" EMBED CRETE-FLEX CONCRETE ANCHOR	9"	1" O.D.
3350 PSI MIN. CONCRETE	1/4" X 1-3/4" EMBED CRETE-FLEX CONCRETE ANCHOR	23"	1" O.D.
2000 PSI MIN. CONCRETE	1/4" X 1-3/4" EMBED TAPCON CONCRETE ANCHOR	16-1/4"	1" O.D.
WOOD FRAME (SYP 0.55 SG)	1/2" X 1-1/2" EMBED LAG SCREW	19-1/4"	1" O.D.

* FIRST (BOTTOM) ANCHOR STARTING AT NO MORE THAN HALF OF THE MAXIMUM ON-CENTER DISTANCE. HIGHEST ANCHOR INSTALLED AT LEAST AS HIGH AS THE DOOR OPENING.
CLOPAY DOES NOT SUPPLY JAMB ATTACHMENT FASTENERS.
MINIMUM DISTANCE BETWEEN CENTER OF ANCHOR AND EDGE OF CONCRETE BLOCK: 2-1/2", EXCLUDING STUCCO THICKNESS.

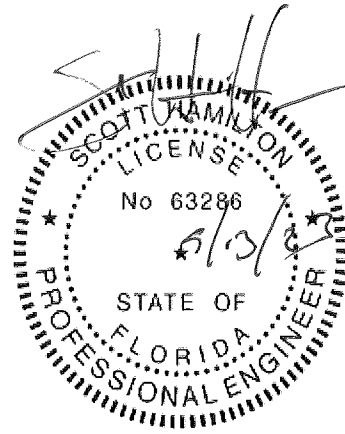

DESIGN ENGINEER:
SCOTT HAMILTON, P.E.
FLORIDA LICENSE No. 63286

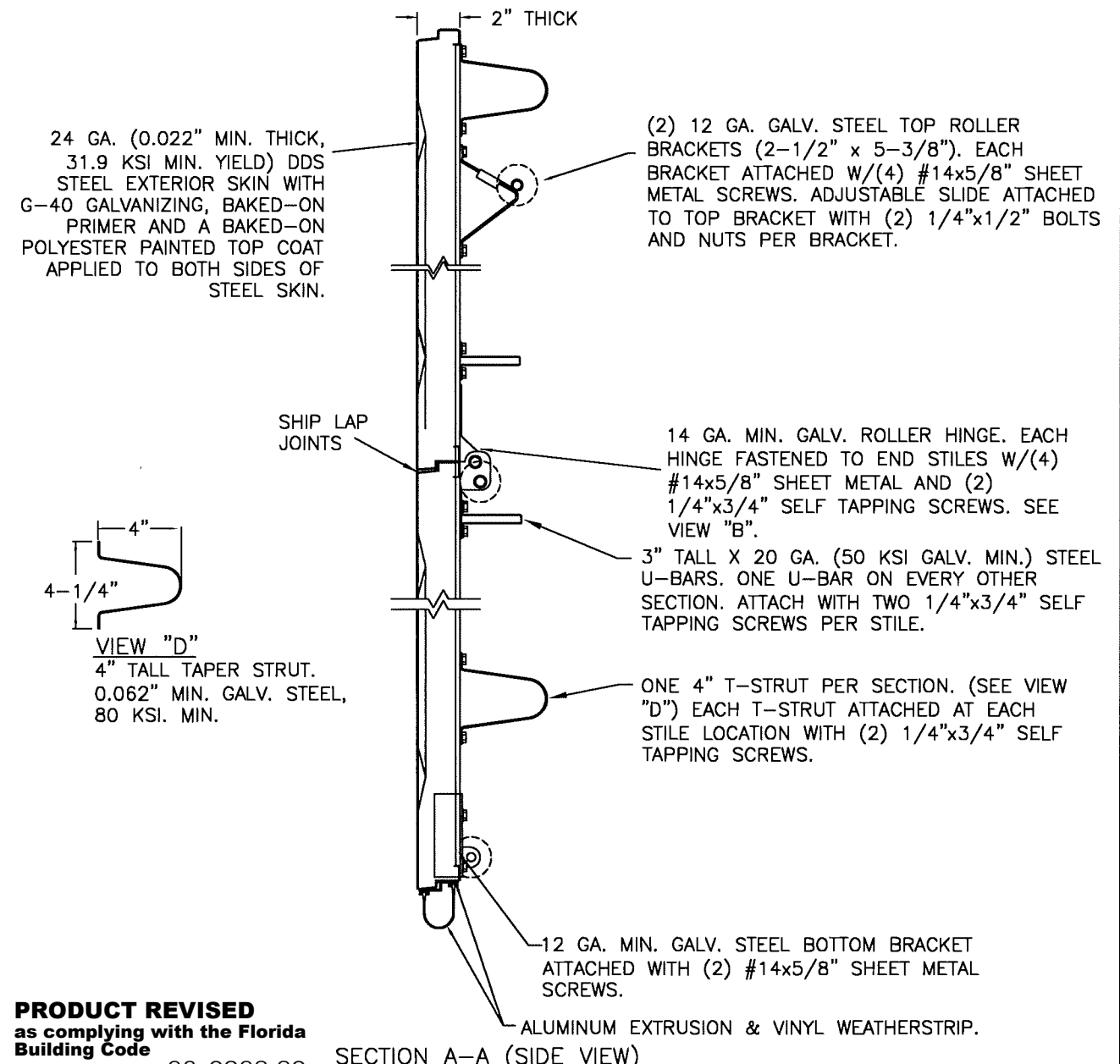
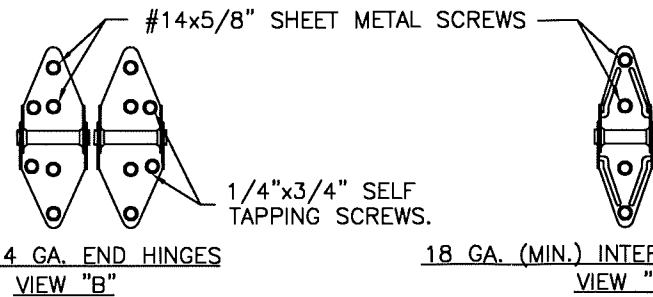

PRODUCT REVISED
as complying with the Florida Building Code
NOA-No. 23-0928.80
Expiration Date 04/11/2028
By *[Signature]*
Miami-Dade Product Control

DESIGN LOADS: +36.0 P.S.F. & -42.0 P.S.F.	PART NO.: N/A
Unless Stated Otherwise TOLERANCES are .0 = ±.031 .00 = ±.015 .000 = ±.005 .0000 = ±.001 Degrees = ±1/2°	WINDLOAD RATING W6 DP36
DESCRIPTION: 2" STEEL PAN DOORS 18'2" (SEE TABLE FOR MODELS)	8585 Duke Boulevard Mason, OH 45040 USA Tel. No. 513-770-4800 Fax No. 513-770-4853
DRAWN BY: SH	DATE: 11/6/12
CHECKED BY: SH	DATE: 11/8/12
DWG. NO.: 104761	VER: MD
SCALE: NTS	DWG. SIZE B
SHEET 2 OF 3	

MODELS	24 GA SHORT	24 GA FLUSH
CLOPAY	84A, 94	98
HOLMES	48, 48B	--
IDEAL	4RST	4F

SHEET:
3 OF 3

REVISIONS					DESCRIPTION
REV. NO.	ZONE:	DATE:	ECN NO.	APPVD:	
07	-	-	-	-	SEE REVISION HISTORY ON SHEET ONE.

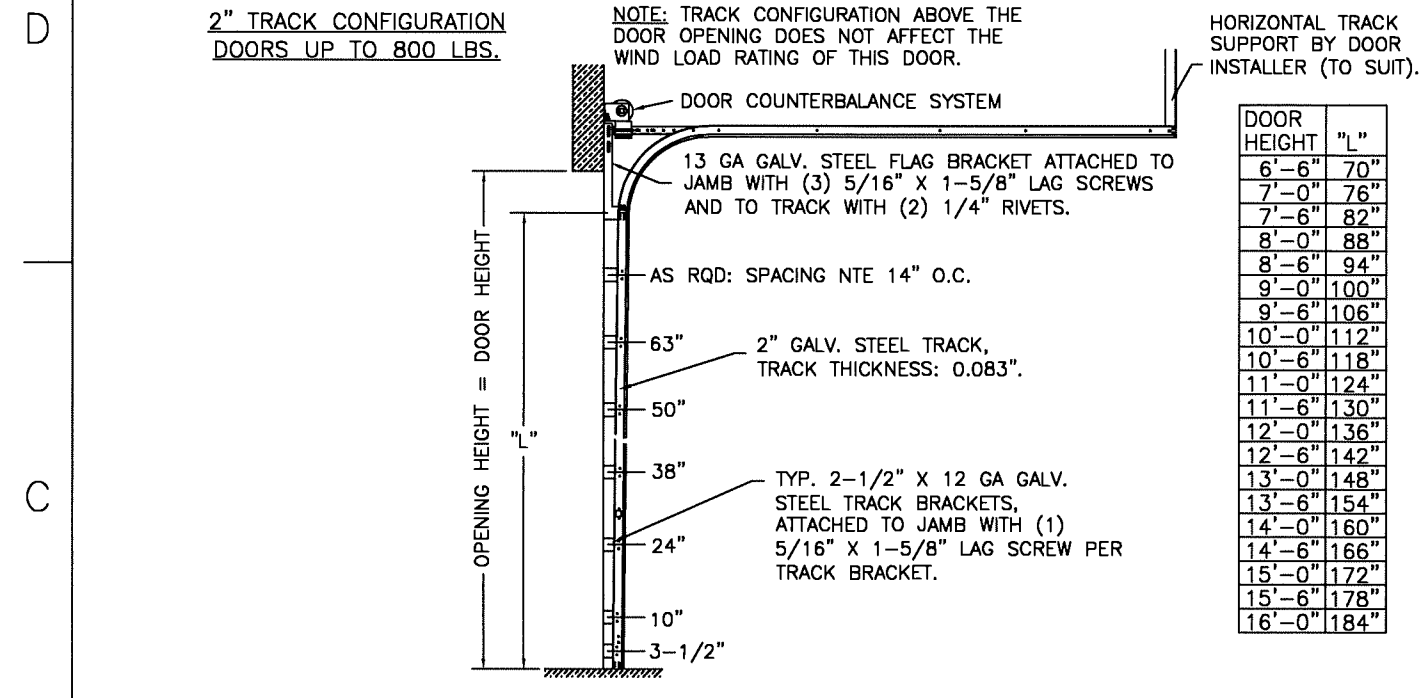

DOOR HEIGHT	"L"
6'-6"	70"
7'-0"	76"
7'-6"	82"
8'-0"	88"
8'-6"	94"
9'-0"	100"
9'-6"	106"
10'-0"	112"
10'-6"	118"
11'-0"	124"
11'-6"	130"
12'-0"	136"
12'-6"	142"
13'-0"	148"
13'-6"	154"
14'-0"	160"
14'-6"	166"
15'-0"	172"
15'-6"	178"
16'-0"	184"

JAMB CONFIGURATION
DOORS UP TO 800 LBS.

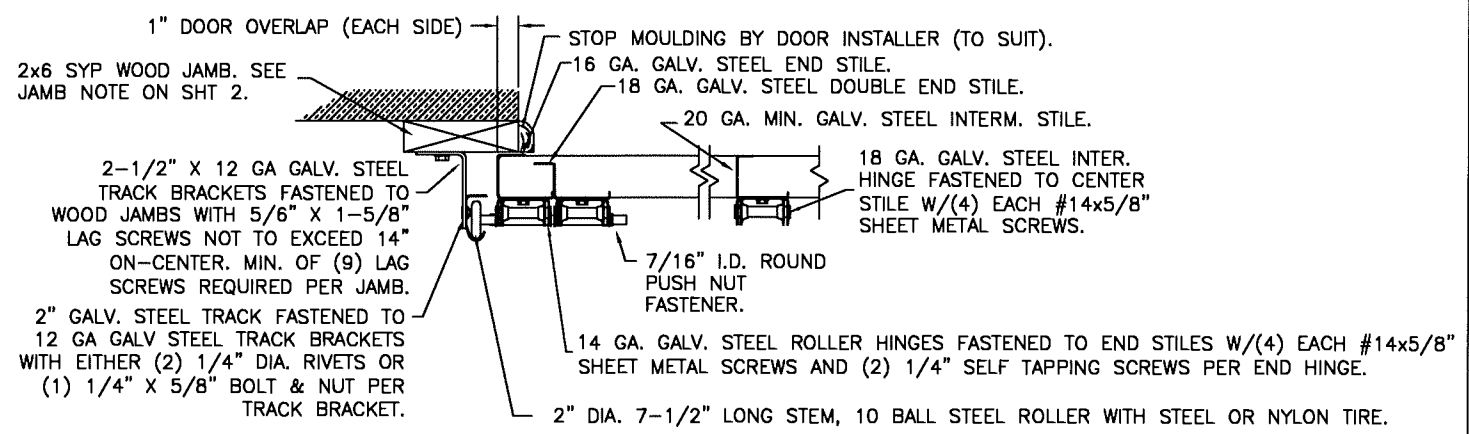

SECTION C-C

PREPARATION OF JAMBS BY OTHERS.

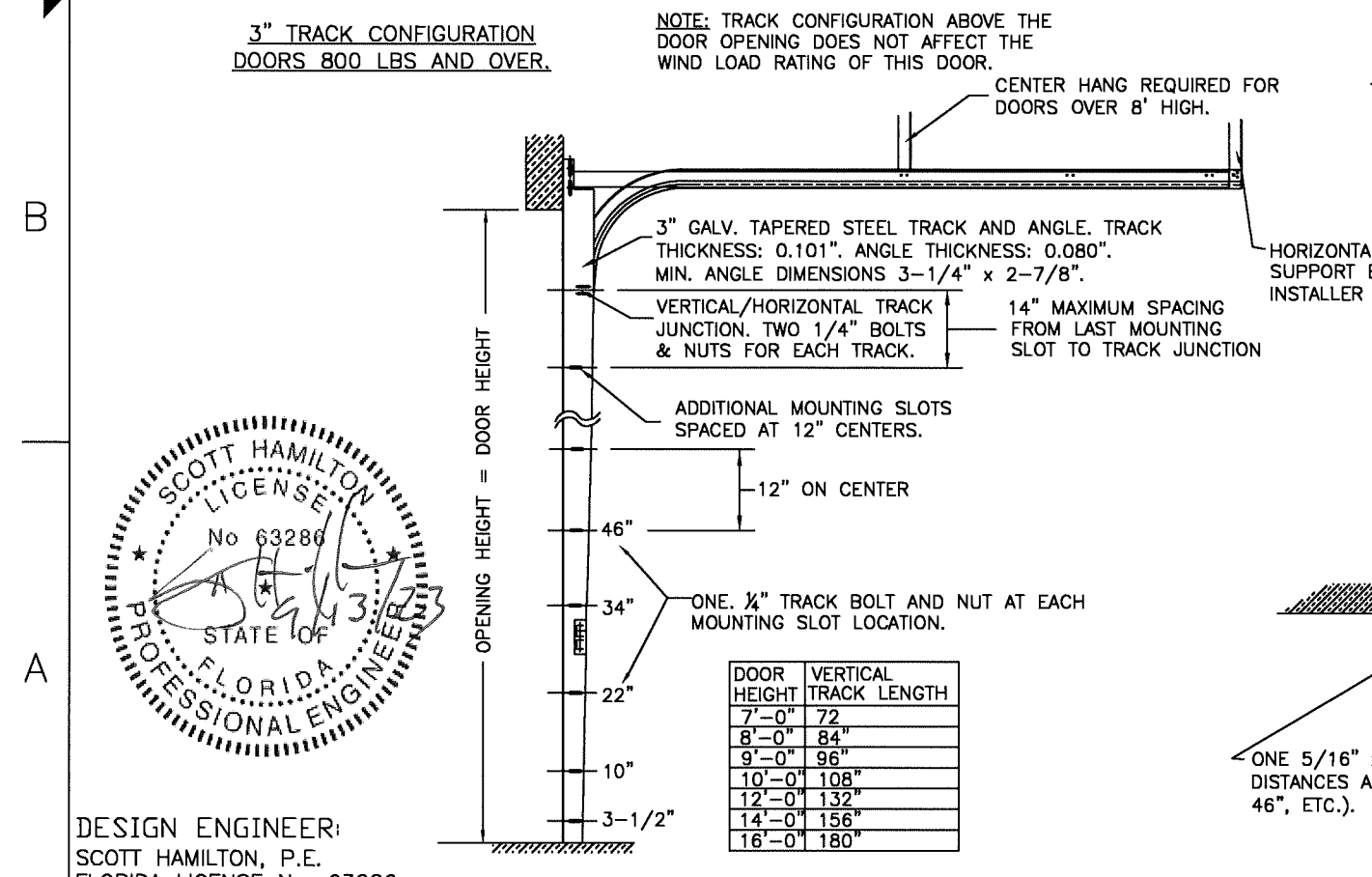
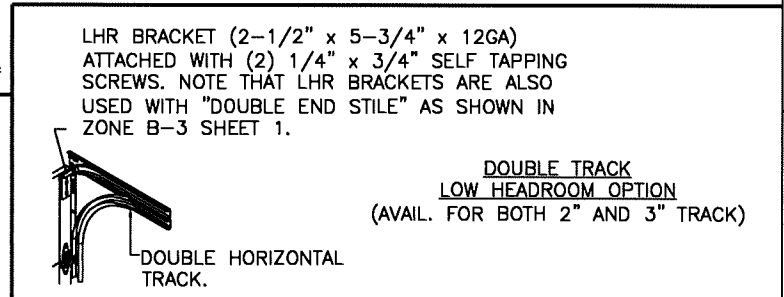

DOOR HEIGHT	VERTICAL TRACK LENGTH
7'-0"	72"
8'-0"	84"
9'-0"	96"
10'-0"	108"
12'-0"	132"
14'-0"	156"
16'-0"	180"

JAMB CONFIGURATION
DOORS 800 LBS AND OVER.

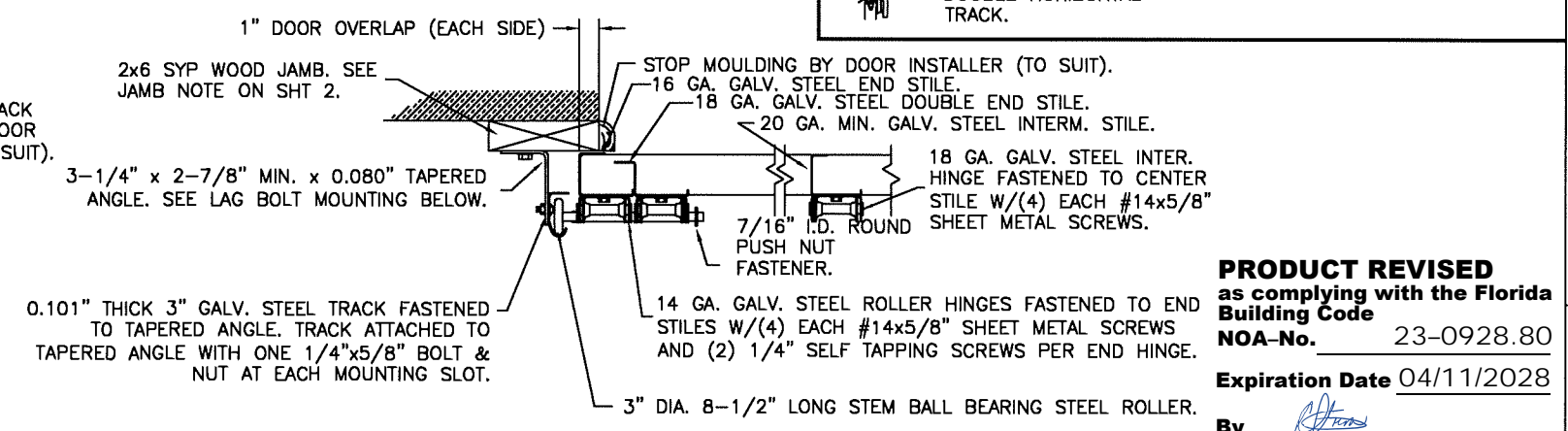

SECTION C-C

PREPARATION OF JAMBS BY OTHERS.

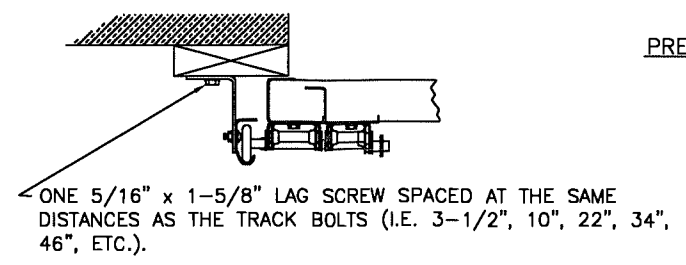

PRODUCT REVISED
as complying with the Florida Building Code
NOA-No. 23-0928.80
Expiration Date 04/11/2028
By *[Signature]*
Miami-Dade Product Control

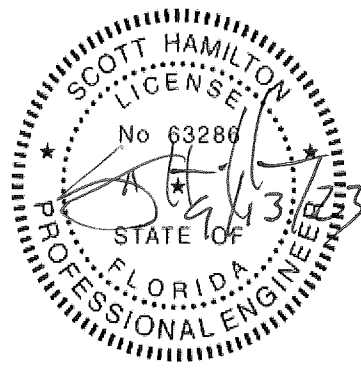

DESIGN ENGINEER:
SCOTT HAMILTON, P.E.
FLORIDA LICENSE No. 63286

DESIGN LOADS: +36.0 P.S.F. & -42.0 P.S.F.

Unless Stated Otherwise TOLERANCES are
.0 = ±.031
.00 = ±.015
.000 = ±.005
.0000 = ±.001
Degrees = ±1/2"
Unless Stated Otherwise DIMENSIONS ARE IN INCHES.

Glopay CORPORATION
8585 Duke Boulevard
Mason, OH 45040 USA
Tel. No. 513-770-4800
Fax No. 513-770-4853

PART NO.: N/A

WINDLOAD RATING
W6 DP36

DESCRIPTION: 2" STEEL PAN DOORS 18'2" (SEE TABLE FOR MODELS)

DRAWN BY: SH	DATE: 11/6/12	SCALE: NTS	DWG. SIZE B
CHECKED BY: SH	DATE: 11/8/12	SHEET 3 OF 3	
DWG. NO.: 104761		VER: MD	