



DEPARTMENT OF REGULATORY AND ECONOMIC RESOURCES (RER)
BOARD AND CODE ADMINISTRATION DIVISION

MIAMI-DADE COUNTY
PRODUCT CONTROL SECTION
11805 SW 26 Street, Room 208
Miami, Florida 33175-2474
T (786) 315-2590 F (786) 315-2599

www.miamidade.gov/economy

NOTICE OF ACCEPTANCE (NOA)

Plenums of Florida, Inc.
P O Box 1890
Pinellas Park, FL 33780

SCOPE:

This NOA is being issued under the applicable rules and regulations governing the use of construction materials. The documentation submitted has been reviewed and accepted by Miami-Dade County RER- Product Control Section to be used in Miami Dade County and other areas where allowed by the Authority Having Jurisdiction (AHJ).

This NOA shall not be valid after the expiration date stated below. The Miami-Dade County Product Control Section (In Miami Dade County) and/or the AHJ (in areas other than Miami Dade County) reserve the right to have this product or material tested for quality assurance purposes. If this product or material fails to perform in the accepted manner, the manufacturer will incur the expense of such testing and the AHJ may immediately revoke, modify, or suspend the use of such product or material within their jurisdiction. RER reserves the right to revoke this acceptance if it is determined by Miami-Dade County Product Control Section that this product or material fails to meet the requirements of the applicable building code.

This product is approved as described herein and has been designed to comply with the High Velocity Hurricane Zone of the Florida Building Code.

DESCRIPTION: TC42A, 43A, 44 Series Steel Roof-Curb for Trane Rooftop Units

APPROVAL DOCUMENT: Drawing No. 15-187-TC Series-ER-6th, titled " Steel Roof curbs for Trane Rooftop Units ", sheets 1 through 11 of 11, prepared by James L. Buckner, P.E., dated March 28, 2016, last revision dated November 13, 2023, signed and sealed by James L. Buckner, P.E., bearing the Miami-Dade County Product Control Revision stamp with the Notice of Acceptance number and the expiration date by the Miami-Dade County Product Control Section.

MISSILE IMPACT RATING: None

LABELING: Each roof-curb shall bear a permanent label with the manufacturer's name or logo, Pinellas Park, Florida and the following statement: "Miami-Dade County Product Control Approved", unless otherwise noted herein.

RENEWAL of this NOA shall be considered after a renewal application has been filed and there has been no change in the applicable building code negatively affecting the performance of this product.

TERMINATION of this NOA will occur after the expiration date or if there has been a revision or change in the materials, use, and/or manufacture of the product or process. Misuse of this NOA as an endorsement of any product, for sales, advertising or any other purposes shall automatically terminate this NOA. Failure to comply with any section of this NOA shall be cause for termination and removal of NOA.

ADVERTISEMENT: The NOA number preceded by the words Miami-Dade County, Florida, and followed by the expiration date may be displayed in advertising literature. If any portion of the NOA is displayed, then it shall be done in its entirety.

INSPECTION: A copy of this entire NOA shall be provided to the user by the manufacturer or its distributors and shall be available for inspection at the job site at the request of the Building Official.

This NOA revises NOA #22-0407.02 and consists of this page 1, evidence submitted pages E-1, E-2, and E-3 as well as approval document mentioned above.

The submitted documentation was reviewed by **Helmy A. Makar, P.E., M.S.**



Helmy A. Makar
02/22/24

NOA No. 23-1122.10
Expiration Date: 05/04/2027
Approval Date: 02/22/2024

Plenums of Florida, Inc.

NOTICE OF ACCEPTANCE: EVIDENCE SUBMITTED

1. EVIDENCE SUBMITTED UNDER PREVIOUS APPROVAL # 15-1221.02

A. DRAWINGS

1. *Drawing No. 15-187-TC Series-ER, titled " Steel Roof curbs for Trane Rooftop Units ", sheets 1 through 11 of 11, prepared by James L. Buckner, P.E., dated March 28, 2016, last revision #1 dated April 07, 2017, signed and sealed by James L. Buckner, P.E.*

B. TESTS

1. *None.*

C. CALCULATIONS

1. *Calculation titled "Test Analysis", dated March 28, 2016, 14 sheets, signed and sealed by James L. Buckner, P.E.*

D. QUALITY ASSURANCE

1. *By Miami-Dade County Department of Regulatory and Economic Resources.*

E. MATERIAL CERTIFICATIONS

1. *None.*

2. EVIDENCE SUBMITTED UNDER PREVIOUS APPROVAL # 18-0516.08

A. DRAWINGS

1. *Drawing No. 15-187-TC Series-ER, titled " Steel Roof curbs for Trane Rooftop Units ", sheets 1 through 11 of 11, prepared by James L. Buckner, P.E., dated March 28, 2016, last revision dated April 15, 2018, signed and sealed by James L. Buckner, P.E.*

B. TESTS

1. *None.*

C. CALCULATIONS

1. *None.*

D. QUALITY ASSURANCE

1. *By Miami-Dade County Department of Regulatory and Economic Resources.*

E. MATERIAL CERTIFICATIONS

1. *None.*

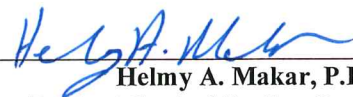

Helmy A. Makar, P.E., M.S.
Product Control Section Supervisor
NOA No. 23-1122.10
Expiration Date: 05/04/2027
Approval Date: 02/22/2024

Plenums of Florida, Inc.

NOTICE OF ACCEPTANCE: EVIDENCE SUBMITTED

3. EVIDENCE SUBMITTED UNDER PREVIOUS APPROVAL # 21-0312.15

A. DRAWINGS

1. *Drawing No. 15-187-TC Series-ER-6th, titled "Steel Roof curbs for Trane Roof top Units", sheets 1 through 11 of 11, prepared by James L. Buckner, P.E., dated 03/28/16, last revision dated 03/11/21, signed/sealed by James L. Buckner, P.E.*

B. TESTS

1. *None.*

C. CALCULATIONS

1. *None.*

D. QUALITY ASSURANCE

1. *By Miami-Dade County Department of Regulatory and Economic Resources.*

E. MATERIAL CERTIFICATIONS

1. *None.*

F. STATEMENTS

1. *FBC, 2020 Edition Compliance Letter prepared by James L. Buckner, P.E., dated March 11, 2021, signed and sealed by James L. Buckner, P.E.*

4. EVIDENCE SUBMITTED UNDER PREVIOUS APPROVAL # 22-0407.02

A. DRAWINGS

1. *None.*

B. TESTS

1. *None.*

C. CALCULATIONS

1. *None.*

D. QUALITY ASSURANCE

1. *By Miami-Dade County Department of Regulatory and Economic Resources.*

E. MATERIAL CERTIFICATIONS

1. *None.*

F. STATEMENTS

1. *FBC, 2020 Edition Compliance Letter prepared by James L. Buckner, P.E., dated March 11, 2021, signed and sealed by James L. Buckner, P.E.*

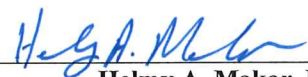

Helmy A. Makar, P.E., M.S.
Product Control Section Supervisor
NOA No. 23-1122.10
Expiration Date: 05/04/2027
Approval Date: 02/22/2024

Plenums of Florida, Inc.

NOTICE OF ACCEPTANCE: EVIDENCE SUBMITTED

5. NEW EVIDENCE SUBMITTED

A. DRAWINGS

1. *Drawing No. 15-187-TC Series-ER-6th, titled " Steel Roof curbs for Trane Rooftop Units ", sheets 1 through 11 of 11, prepared by James L. Buckner, P.E., dated March 28, 2016, last revision dated November 13, 2023.*

B. TESTS

1. *None.*

C. CALCULATIONS

1. *None.*

D. QUALITY ASSURANCE

1. *By Miami-Dade County Department of Regulatory and Economic Resources.*

E. MATERIAL CERTIFICATIONS

1. *None.*

F. STATEMENTS

1. *FBC, 2023 Edition Compliance Letter prepared by James L. Buckner, P.E., dated 11/09/2023, signed and sealed by James L. Buckner, P.E.*



Helmy A. Makar, P.E., M.S.
Product Control Section Supervisor
NOA No. 23-1122.10
Expiration Date: 05/04/2027
Approval Date: 02/22/2024

Engineering Report & Drawings
Of
Plenums of Florida, Inc.
“TC Series” Trane Roof Curbs
Steel Roof Curbs for Trane Rooftop Units
For
Miami-Dade Notice of Acceptance (N.O.A.)

Category: Roof
Sub - Category: Curb

Prepared by:
James L. Buckner, P.E.
Florida Professional Engineer # 31242

Report No.: 15-187-TC Series-ER-6th
 Rev Date: 4 / 15 / 18
 Report : 20-255-TC Series-ER-7th
 Rev Date 3 / 11 / 2021
 Report 23-589-TC_Series-ER-8th
 Rev 11/13/23

<u>Contents:</u>	
Cover Page	Page 1
Product & Evaluation Scope	Page 2 - 3
Installation Drawings	Page 4 - 5
Assembly Drawings	Page 6 - 7
Components	Page 8 - 11

PRODUCT REVISED
 as complying with the Florida
 Building Code
 Acceptance No 23-1122.10
 Expiration Date 05/04/2027
 By H. J. A. Miller
 Miami Dade Product Control

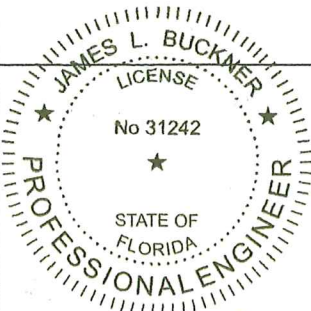

James L. Buckner
 11/9/23

**Plenums “TC Series” Trane Roof Curbs
 ENGINEERING REPORT**

CBUCK Engineering
 Speciality Structural Engineering
 CBUCK, Inc. COA #8064
 www.cbuckinc.net
 (561) 491-9927
 1374 Community Drive
 Jupiter, FL 33458

MANUFACTURER:
 Plenums of Florida, Inc.
 P.O. Box 1890
 Pinellas Park, FL 33780

DATE:	3 / 28 / 16
PAGE #:	1 OF 11
REPORT #:	15-187-TC Series-ER-6th
PROJECT #:	15-187
DRAWN BY:	YD
REVISION :	11/13/2023

1.0 Product:

- 1.1 **Manufacturer:** Plenums of Florida, Inc.
- 1.2 **Product Name:** "TC Series" Trane Roof Curbs
- 1.3 **Category:** Roof
- 1.4 **Subcategory:** Curb

2.0 Evaluation Scope:

2.1 Evaluation Criteria:

Florida Building Code (FBC) 8th Edition (2023)
 Code Section: High Velocity Hurricane Zone (HVHZ)
 Miami-Dade Department Of Regulatory And Economic Resources, Product Control Section Checklist and Criteria

2.2 Properties Evaluated:

Assembly Wind Resistance (Curb & Simulated Trane Unit)
 Uplift & Vertical Down
 Lateral
 Overturning
 Component Material Properties

2.3 Limits of Evaluation:

This product is limited to compliance with the criteria in section 2.1 and properties in section 2.2 of this report.

3.0 Evaluated Uses:

Roof Curbs attached to building structural to support Trane rooftop mechanical units.

4.0 Assembly Description:

4.1 General:

"TC Series" are steel roof curbs to support Trane rooftop mechanical units.
 Curb perimeter walls 16 gauge minimum.

4.2 Curb Dimensions:

4.3 Curb Assembly & Components:

See Pages 6 - 11

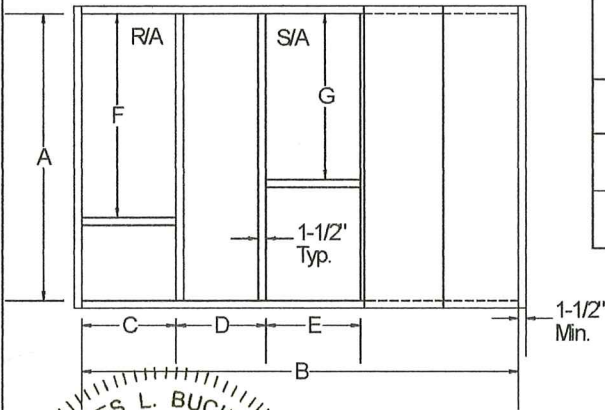

Plenums Curb Model #	A	B	C	D	E	F	G
TC42A	37-7/16"	61-13/16"	14-9/16"	8-3/8"	16-3/4"	25-3/16"	17-7/8"
TC43A	46-3/8"	80-1/2"	18-1/4"	8-5/8"	18-1/2"	34-3/8"	34-3/8"
TC44	56-3/8"	80-1/2"	18-1/2"	8-5/8"	18-1/2"	34-3/8"	34-3/8"

PRODUCT REVISED
 as complying with the Florida
 Building Code
 Acceptance No 23-1122.10
 Expiration Date 05/04/2027
 By *H. A. Miller*
 Miami Dade Product Control

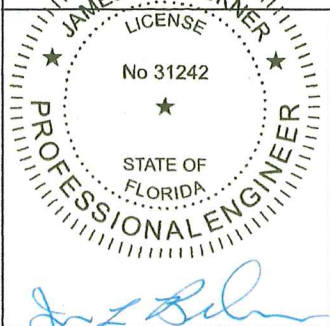

Plenums "TC Series" Trane Roof Curbs
 ENGINEERING REPORT

CBUCK Engineering
 Specialty Structural Engineering
 CBUCK, Inc. COA #8064
 www.cbuckinc.net
 (561) 491-9927
 1374 Community Drive
 Jupiter, FL 33458

MANUFACTURER:
 Plenums of Florida, Inc.
 P.O. Box 1890
 Pinellas Park, FL 33780

DATE:	3 / 28 / 16
PAGE #:	2 OF 11
REPORT #:	15-187-TC Series-ER-6th
PROJECT #:	15-187
DRAWN BY:	YD
REVISION :	11/13/2023

5.0 Curb Steel Supports:

The building support structural is designed by others and shall have the following minimum Characteristics:

- 5.1 Type: Structural Support (Beam, Purlin, Bar Joist)
- 5.2 Material: Steel
- 5.3 Top Flange Size: 3" Minimum Width
- 5.4 Top Flange Thickness: 1/4" Minimum
- 5.5 Yield Strength: 33 ksi Minimum
- 5.6 Support Location: Curb perimeter
Design of support by others

6.0 Performance:

6.1 Maximum Lateral Design Pressure:	87 PSF (ASD) Applied to Curb & Trane Unit Vertical Walls
6.2 Maximum Uplift Design Pressure:	102 PSF (ASD) Applied to Curb/Unit Assembly

7.0 Installation:

Each curb panel shall be fastened to horizontal supports with 3/8" bolts and nuts spaced 16" o.c. maximum. All screws, bolts, nuts and washers shall be corrosion resistant steel per FBC, HVHZ of 60 ksi minimum tensile strength.
The connection of the steel supports to the existing supporting structure is not part of this product control approval and it shall be submitted to permitting jurisdiction for review and approval.
Refer to Drawings on pages 4 through 8 of this report for supplemental installation and components guide.

8.0 Limitations of Use:

- 8.1 The curbs shall be supported by structural steel support complying with the Miami-Dade (Florida High velocity zone) code.
- 8.2 The engineer of record or architect shall verify that the building structure is capable of resisting the superimposed loads from the system and that the supporting structure is capable of providing lateral stability to carry the wind loads to the building foundation.

9.0 Code Compliance

- 9.1 The Roof Curbs in this report meet the High Velocity Hurricane Zone (HVHZ) Requirements of the Florida Building Code, 8th Edition (2023) for the properties evaluated.

10.0 Identification:

- 10.1 Each roof-curb shall bear a permanent label with the manufacturer's name or logo, manufacturing plant's city, state and the statement reading "Miami-Dade County Product Control Approved".

11.0 Reference Data:

- 11.1 ASTM E72 – Strength Test
Report No.: T292-15 Report Date: 10/30/15, Revision Date: 12/14/15
By: Farabaugh Engineering & Testing, Inc.
- 11.2 Test Analysis, Titled Test Analysis for NOA #15-1221.02, dated: 3/28/16
signed and sealed by James L. Buckner P.E.

PRODUCT REVISED
as complying with the Florida
Building Code
Acceptance No 23-1122.10
Expiration Date 05/04/2027
By Helga A. Miller
Miami Dade Product Control

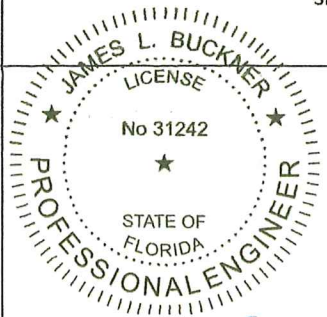

James L. Buckner
11/9/23

Plenums "TC Series" Trane Roof Curbs ENGINEERING REPORT		DATE: 3 / 28 / 16
 CBUCK, Inc. COA #8064 www.cbuckinc.net (561) 491-9927 1374 Community Drive Jupiter, FL 33458	MANUFACTURER:	PAGE #: 3 OF 11
	Plenums of Florida, Inc.	REPORT #: 15-187-TC Series-ER-6th
	P.O. Box 1890	PROJECT #: 15-187
	Pinellas Park, FL 33780	DRAWN BY: YD
		REVISION : 11/13/2023

PLENUMS OF FLORIDA, INC.
"TC Series" Trane Roof Curb & Unit
INSTALLATION DRAWINGS
Curb to Support

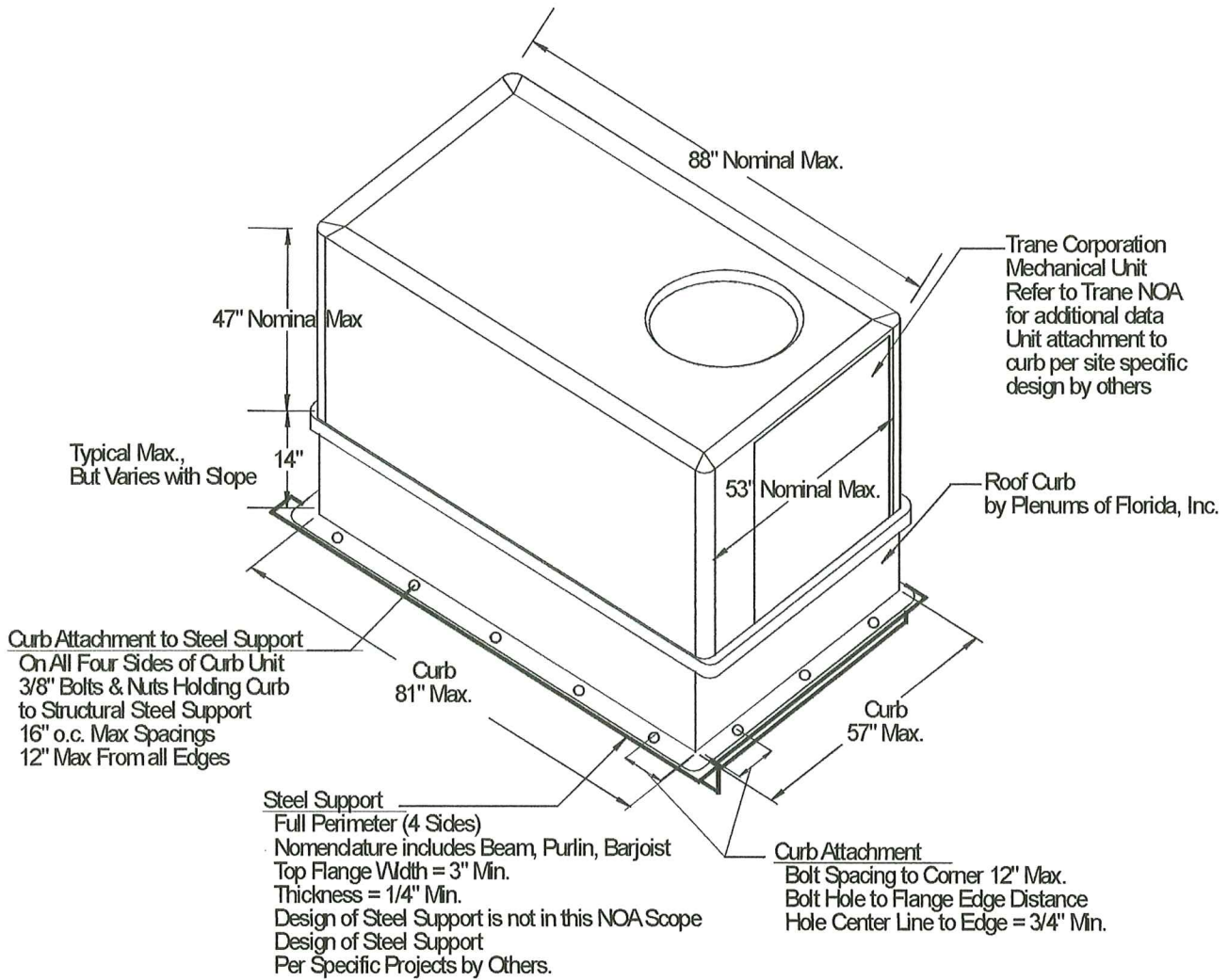

Typical A/C Unit & Curb Assembly
Isometric View

PRODUCT REVISED
as complying with the Florida
Building Code
Acceptance No 23-1122.10
Expiration Date 05/04/2027
By Holly A. Miller
Miami Trade Product Control

- NOTES:
- REFER TO TRANE NOA REPORT FOR SPECIFICATIONS AND DESIGN DATA.
 - REFER TO MANUFACTURER INSTALLATION INSTRUCTIONS FOR CURB SUPPLEMENTAL DETAILS

NOT TO SCALE

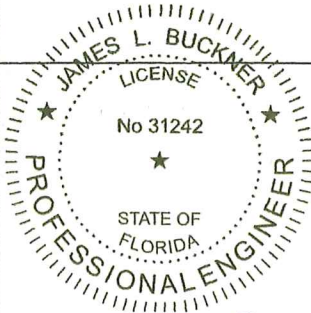

Plenums "TC Series" Trane Roof Curbs
ENGINEERING REPORT

CBUCK Engineering
Specialty Structural Engineering
CBUCK, Inc. COA #8064
www.cbuckinc.net
(561) 491-9927
1374 Community Drive
Jupiter, FL 33458

MANUFACTURER:
Plenums of Florida, Inc.
P.O. Box 1890
Pinellas Park, FL 33780

DATE: 3 / 28 / 16
PAGE #: 4 OF 11
REPORT #: 15-187-TC Series-ER-6th
PROJECT #: 15-187
DRAWN BY: YD
REVISION : 11/13/2023

J. L. Buckner
11/9/23

PLENUMS OF FLORIDA, INC.

**"TC Series" Trane Roof Curb
INSTALLATION DRAWINGS
Curb to Support**

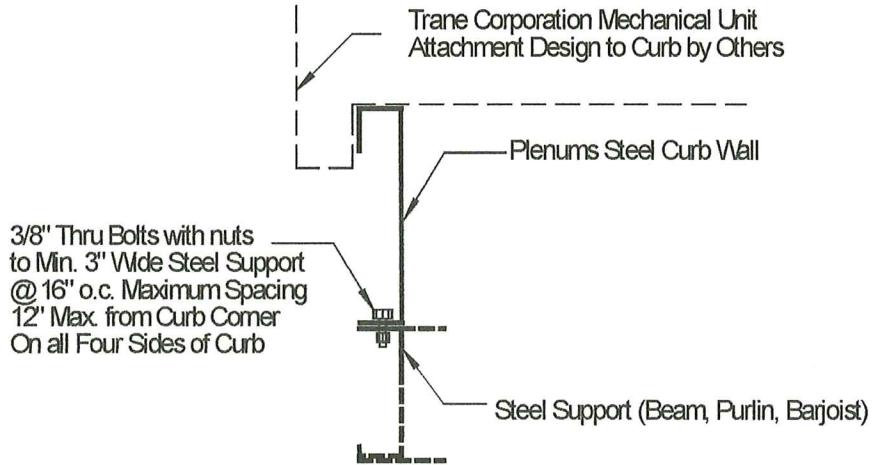

Typical Curb Perimeter Section

NOTES:
1. REFER TO MANUFACTURER INSTALLTION INSTRUCTIONS FOR SUPPLEMENTAL DETAILS

PRODUCT REVISED
as complying with the Florida
Building Code
Acceptance No 23-422.00
Expiration Date 05/09/2027
By Hedy A. Miller
Miami Data Product Control

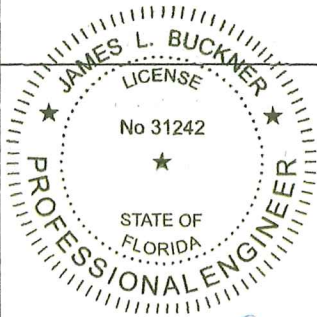

**Plenums "TC Series" Trane Roof Curbs
ENGINEERING REPORT**

CBUCK Engineering
Specialty Structural Engineering
CBUCK, Inc. COA #8064
www.cbuckinc.net
(561) 491-9927
1374 Community Drive
Jupiter, FL 33458

MANUFACTURER:
Plenums of Florida, Inc.
P.O. Box 1890
Pinellas Park, FL 33780

DATE:	3 / 28 / 16
PAGE #:	5 OF 11
REPORT #:	15-187-TC Series-ER-6th
PROJECT #:	15-187
DRAWN BY:	YD
REVISION :	11/13/2023

11/9/23

PLENUMS OF FLORIDA, INC.

**"TC Series" Trane Roof Curb
ASSEMBLY DRAWINGS
Curb Assembly**

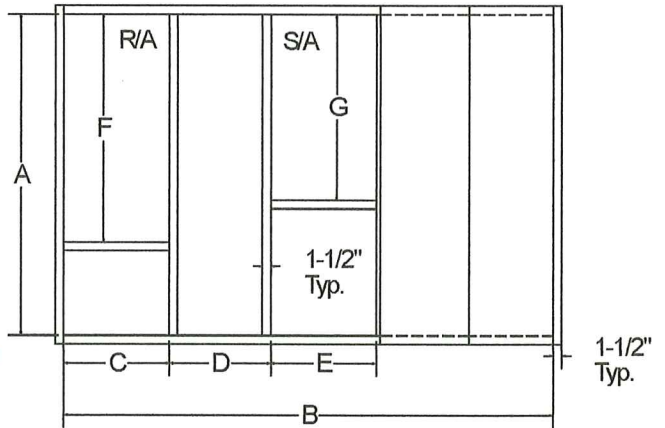
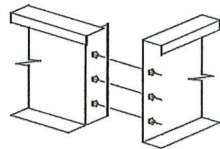
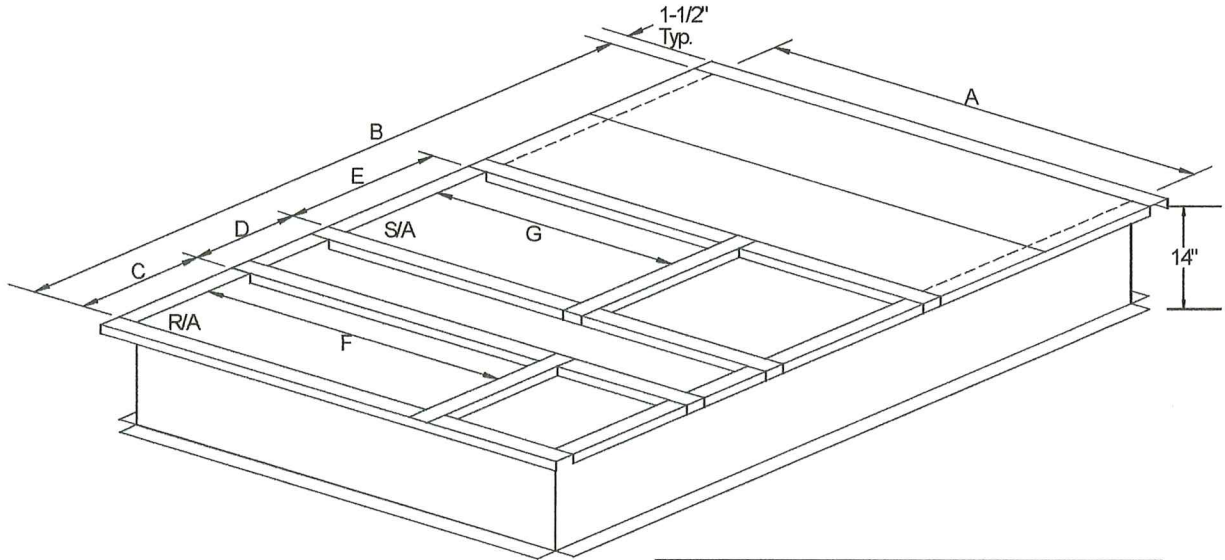

PRODUCT REVISED
as complying with the Florida
Building Code
Acceptance No. 23-1/22.10
Expiration Date 05/04/2027
By [Signature]
Miami Date Product Control

NOT TO SCALE

DIMENSIONAL DATA

TRANE UNIT MODEL	TRANE UNIT WEIGHT	PLENUMS INC. CURB MODEL #	A	B	C	D	E	F	G
TSC/YSC036-060E/F THC/YHC036E/F & WSC036/048E	561 lbs (Max.)	TC42A	37-7/16"	61-13/16"	14-9/16"	8-3/8"	16-3/4"	25-3/16"	17-7/8"
TSC/YSC/072-120E/F & THC/YHC048-072E/F WSC060-092E & THC/YHC092F	1026 lbs (Max.)	TC43A	46-3/8"	80-1/2"	18-1/4"	8-5/8"	18-1/2"	34-3/8"	34-3/8"
THC/YHC090-120E/F & WSC120E	1372 lbs (Max.)	TC44	56-3/8"	80-1/2"	18-1/2"	8-5/8"	18-1/2"	34-3/8"	34-3/8"

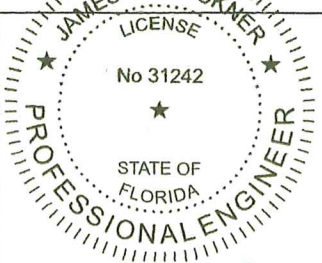

**Plenums "TC Series" Trane Roof Curbs
ENGINEERING REPORT**

CBUCK Engineering
Specialty Structural Engineering
CBUCK, Inc. COA #8064
www.cbuckinc.net
(561) 491-9927
1374 Community Drive
Jupiter, FL 33458

MANUFACTURER:
Plenums of Florida, Inc.
P.O. Box 1890
Pinellas Park, FL 33780

DATE: 3 / 28 / 16
PAGE #: 6 OF 11
REPORT #: 15-187-TC Series-ER-6th
PROJECT #: 15-187
DRAWN BY: YD
REVISION : 11/13/2023

[Signature]
11/9/23

PLENUMS OF FLORIDA, IN

"TC Series" Trane Roof Curb ASSEMBLY DRAWINGS For Curb Field Assembly

(Note: Optional for curbs to be shop welded by Plenums)

STEP 1

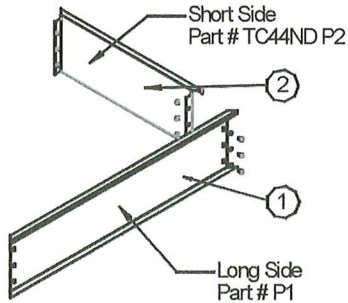

Assemble
ONE Part # P1 and
ONE Part # P2
Using 1/4" Hex Head Bolts
w/ Washers & Keps Nuts
as shown in detail drawing.

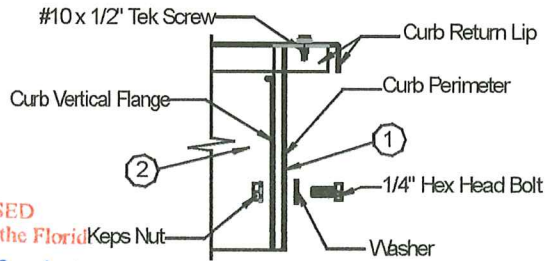

Section at Corner

PRODUCT REVISED
as complying with the Florida
Building Code
Acceptance No 23-1/22.10
Expiration Date 05/04/2027

By *Handwritten Signature*
Miami Dept Product Control

STEP 2

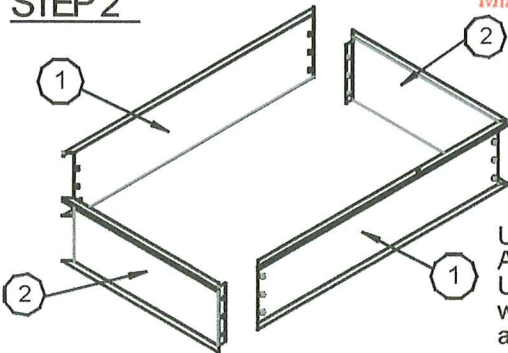

Using Assembly from Step 1
Add the rest of the perimeter
Using 1/4" Hex Head Bolts
w/ Washers & Keps Nuts
as shown in detail drawing.

DIMENSIONAL DATA

PLENUMS INC. CURB MODEL #	G	E	D	C	F
TC42A	17-7/8"	16-3/4"	8-3/8"	14-9/16"	25-3/16"
TC43A	34-3/8"	18-1/2"	8-5/8"	18-1/4"	34-3/8"
TC44	34-3/8"	18-1/2"	8-5/8"	18-1/4"	34-3/8"

STEP 3

Add interior Duct Rails
Part #s P3, P4 & P5.
Space Rails per Diagram
shown herein.
Then add Panels
Part # P6.
Install gasket on top of
flanges and
around supply and return
openings as shown.
Fasten Duct Rail with
Tek Screws per Side.

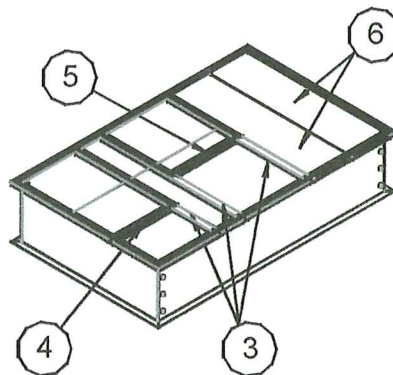
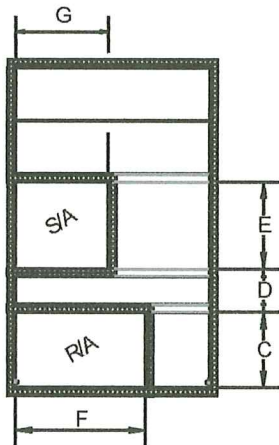

ITEM NO.	PART NUMBER	QTY.
1	P1	2
2	P2	2
3	P3	3
4	P4	1
5	P5	1
6	P6	2 Min.
7	.25-20 Flat Washer	12
8	.25-20 Fully Welded Bolt	12
9	.25-20 Keps Nuts	12
10	Gasket	30
11	Tek Screw	10

* DIMENSIONS SHOWN ARE FOR REFERENCE ONLY AND SHOULD BE COORDINATED WITH DIMENSIONS ON YOUR SPECIFIC CURB MODEL NUMBER SUBMITTAL*

NOT TO SCALE

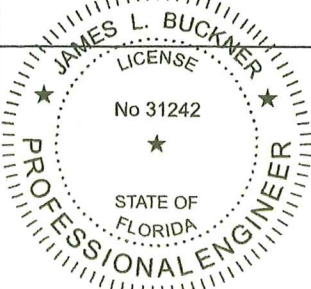

Plenums "TC Series" Trane Roof Curbs ENGINEERING REPORT



CBUCK, Inc. COA #8064
www.cbuckinc.net
(561) 491-9927
1374 Community Drive
Jupiter, FL 33458

MANUFACTURER:

Plenums of Florida, Inc.
P.O. Box 1890
Pinellas Park, FL 33780

DATE: 3 / 28 / 16

PAGE #: 7 OF 11

REPORT #: 15-187-TC Series-ER-6th

PROJECT #: 15-187

DRAWN BY: YD

REVISION : 11/13/2023

Handwritten Signature
11/9/23

COMMON COMPONENTS



CURB TO STEEL SUPPORT BOLT

Purpose: Used to secure Curb to Structural Support
Type: Hex Head Thru Bolts w/ Washers & Nuts
Diameter: 3/8" Minimum
Tensile Strength: 60 ksi Minimum
Corrosion Resistance: Zinc Plated Steel per ANSI/ASME B18.2.1 & SAE J429 Specifications or Per FBC HVHZ



CURB ASSEMBLY BOLT

Purpose: Used to assemble Curb
Type: Hex Head Thru Bolts w/ Washers & Nuts
Size: 1/4"-20 x 5/8" Minimum
Tensile Strength: 60 ksi Minimum
Corrosion Resistance: Zinc Plated Steel per ANSI/ASME B18.2.1 & SAE J429 Specifications or Per FBC HVHZ



TEK SCREW

Purpose: Used to assemble Curb
Type: Hex Washer Head, Self-Drilling Tek Screws
Size: #10 x 1/2" Minimum
Corrosion Resistance: Zinc Plated Steel per ANSI/ASME B18.6.3 & SAE J78 Specifications or per FBC HVHZ

PRODUCT REVISED
 as complying with the Florida
 Building Code
 Acceptance No 23-1122.10
 Expiration Date 05/04/2027
 By Heidi A. Miller
 Miami Data Product Control

NOT TO SCALE

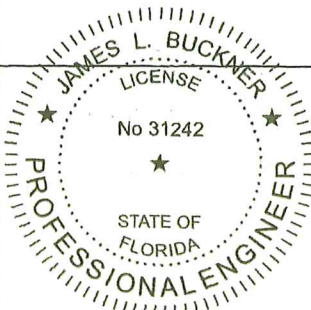

James L. Buckner
 11/9/23

Plenums "TC Series" Trane Roof Curbs ENGINEERING REPORT

CBUCK Engineering
 Specialty Structural Engineering
CBUCK, Inc. COA #8064
 www.cbuckinc.net
 (561) 491-9927
 1374 Community Drive
 Jupiter, FL 33458

MANUFACTURER:
 Plenums of Florida, Inc.
 P.O. Box 1890
 Pinellas Park, FL 33780

DATE:	3 / 28 / 16
PAGE #:	8 OF 11
REPORT #:	15-187-TC Series-ER-6th
PROJECT #:	15-187
DRAWN BY:	YD
REVISION :	11/13/2023

PLENUMS OF FLORIDA, INC.

"TC Series" Trane Roof Curb
TC42A COMPONENTS

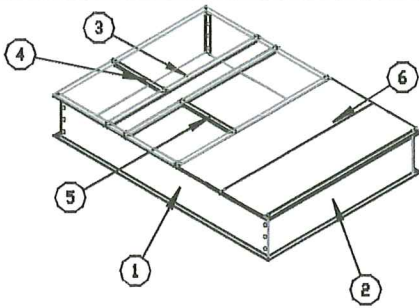

ITEM No.	PART No.	QUANTITY
1	TC42AND P1	2
2	TC42AND P2	2
3	TC42AND P3	3
4	TC42AND P4	1
5	TC42AND P5	1
6	TC42AND P6	2

PRODUCT REVISED
as complying with the Florida
Building Code
Acceptance No 23-1122.10
Expiration Date 05/09/2027
By *H. G. A. Miller*
Miami Dade Product Control

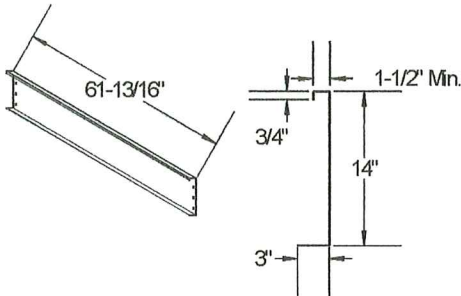

TC42AND P1
QTY. (2)

16 Ga. Steel, 33 ksi Min.
G-90 Galvanized per ASTM A653
or Corrosion resistant per FBC, HVHZ

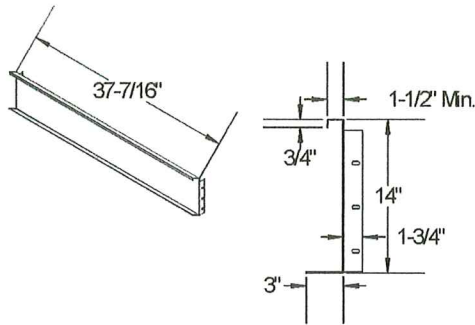

TC42AND P2
QTY. (2)

16 Ga. Steel, 33 ksi Min.
G-90 Galvanized per ASTM A653
or Corrosion resistant per FBC, HVHZ

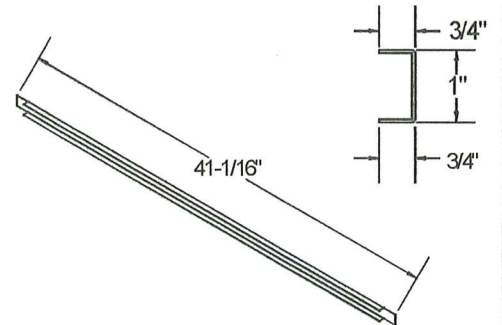

DUCT RAIL TC42AND P3
QTY. (3)

18 Ga. Steel, 33 ksi Min.
G-90 Galvanized per ASTM A653
or Corrosion resistant per FBC, HVHZ

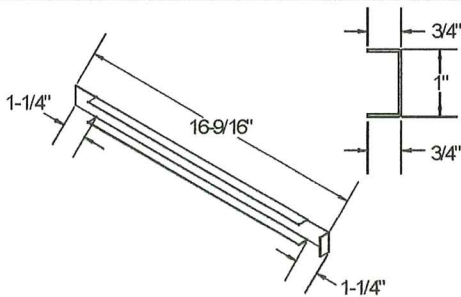

DUCT RAIL TC42AND P4
QTY. (1)

18 Ga. Steel, 33 ksi Min.
G-90 Galvanized per ASTM A653
or Corrosion resistant per FBC, HVHZ

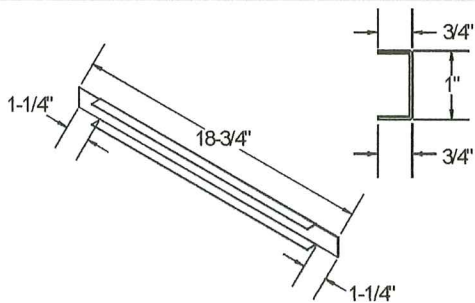

DUCT RAIL TC42AND P5
QTY. (1)

18 Ga. Steel, 33 ksi Min.
G-90 Galvanized per ASTM A653
or Corrosion resistant per FBC, HVHZ

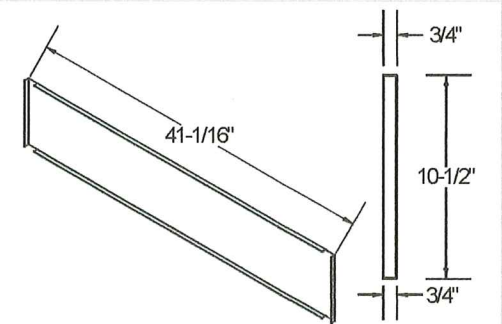

TC42AND P6
QTY. (2)

18 Ga. Steel, 33 ksi Min.
G-90 Galvanized per ASTM A653
or Corrosion resistant per FBC, HVHZ

NOT TO SCALE

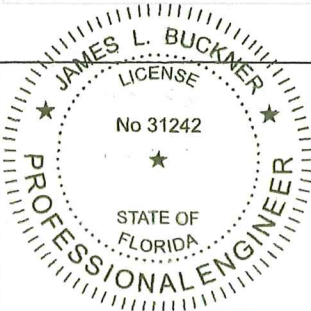

J. L. Buckner
11/9/23

Plenums "TC Series" Trane Roof Curbs
ENGINEERING REPORT

CBUCK Engineering
Specialty Structural Engineering
CBUCK, Inc. COA #8064
www.cbuckinc.net
(561) 491-9927
1374 Community Drive
Jupiter, FL 33458

MANUFACTURER:
Plenums of Florida, Inc.
P.O. Box 1890
Pinellas Park, FL 33780

DATE:	3 / 28 / 16
PAGE #:	9 OF 11
REPORT #:	15-187-TC Series-ER-6th
PROJECT #:	15-187
DRAWN BY:	YD
REVISION :	11/13/2023

PLENUMS OF FLORIDA, INC.

"TC Series" Trane Roof Curb
TC43A COMPONENTS

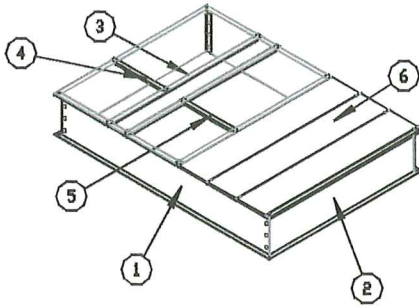

ITEM No.	PART No.	QUANTITY
1	TC43AND P1	2
2	TC43AND P2	2
3	TC43AND P3	3
4	TC43AND P4	1
5	TC43AND P5	1
6	TC43AND P6	3

PRODUCT REVISED
as complying with the Florida
Building Code
Acceptance No 23-1122-10
Expiration Date 05/04/2027
By H. G. Allen
Miami Dade Product Control

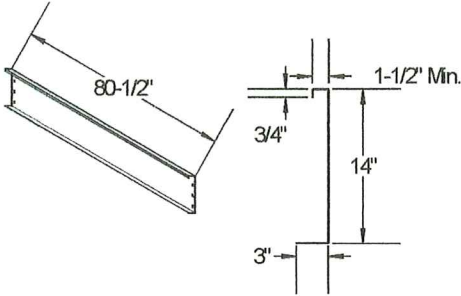

TC43AND P1
QTY. (2)

16 Ga. Steel, 33 ksi Min.
G-90 Galvanized per ASTM A653
or Corrosion resistant per FBC, HVHZ

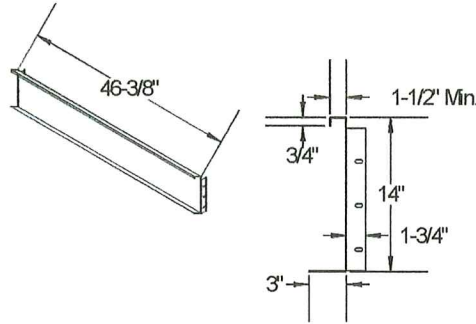

TC43AND P2
QTY. (2)

16 Ga. Steel, 33 ksi Min.
G-90 Galvanized per ASTM A653
or Corrosion resistant per FBC, HVHZ

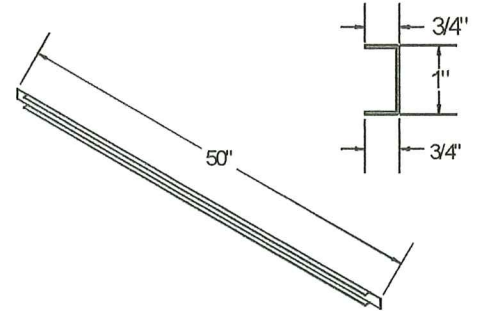

DUCT RAIL TC43AND P3
QTY. (3)

18 Ga. Steel, 33 ksi Min.
G-90 Galvanized per ASTM A653
or Corrosion resistant per FBC, HVHZ

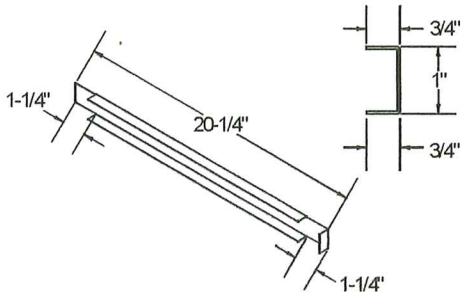

DUCT RAIL TC43AND P4
QTY. (1)

18 Ga. Steel, 33 ksi Min.
G-90 Galvanized per ASTM A653
or Corrosion resistant per FBC, HVHZ

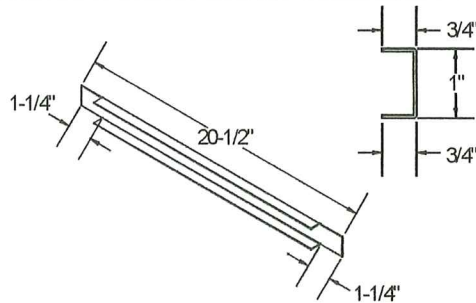

DUCT RAIL TC43AND P5
QTY. (1)

18 Ga. Steel, 33 ksi Min.
G-90 Galvanized per ASTM A653
or Corrosion resistant per FBC, HVHZ

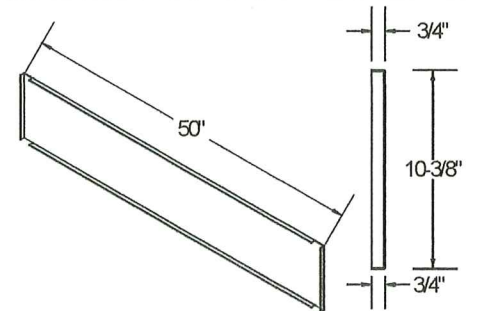

TC43AND P6
QTY. (3)

18 Ga. Steel, 33 ksi Min.
G-90 Galvanized per ASTM A653
or Corrosion resistant per FBC, HVHZ

NOT TO SCALE

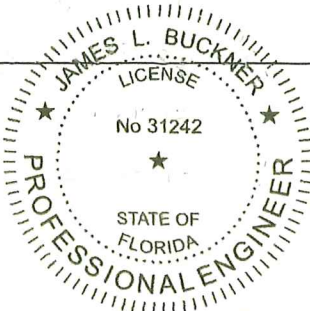

James L. Buckner
11/9/23

Plenums "TC Series" Trane Roof Curbs
ENGINEERING REPORT

CBUCK Engineering
Specialty Structural Engineering
CBUCK, Inc. COA #8064
www.cbuckinc.net
(561) 491-9927
1374 Community Drive
Jupiter, FL 33458

MANUFACTURER:
Plenums of Florida, Inc.
P.O. Box 1890
Pinellas Park, FL 33780

DATE:	3 / 28 / 16
PAGE #:	10 OF 11
REPORT #:	15-187-TC Series-ER-6th
PROJECT #:	15-187
DRAWN BY:	YD
REVISION :	11/13/2023

PLENUMS OF FLORIDA, INC.

"TC Series" Trane Roof Curb
TC44 COMPONENTS

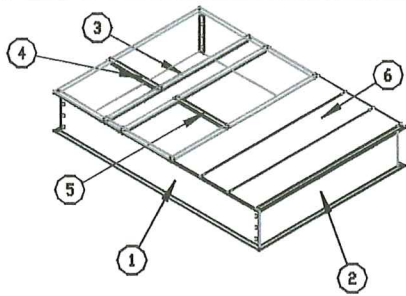

ITEM No.	PART No.	QUANTITY
1	TC44ND P1	2
2	TC44ND P2	2
3	TC44ND P3	3
4	TC44ND P4	1
5	TC44ND P5	1
6	TC44ND P6	3

PRODUCT REVISED
as complying with the Florida
Building Code
Acceptance No. 23-1122.10
Expiration Date 05/04/2027
By *Hedy A. Miller*
Miami Date Product Control

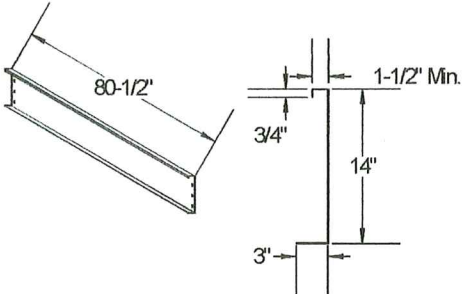

TC44ND P1

QTY. (2)

16 Ga. Steel, 33 ksi Min.
G-90 Galvanized per ASTM A653
or Corrosion resistant per FBC, HVHZ

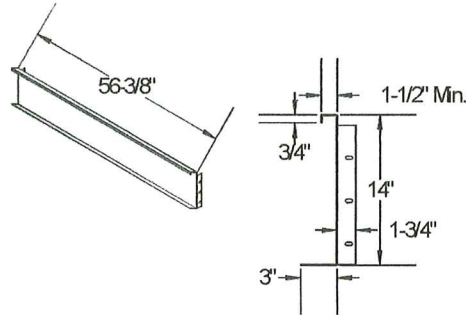

TC44ND P2

QTY. (2)

16 Ga. Steel, 33 ksi Min.
G-90 Galvanized per ASTM A653
or Corrosion resistant per FBC, HVHZ

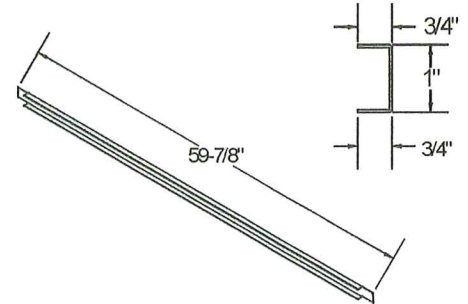

DUCT RAIL TC44ND P3

QTY. (3)

18 Ga. Steel, 33 ksi Min.
G-90 Galvanized per ASTM A653
or Corrosion resistant per FBC, HVHZ

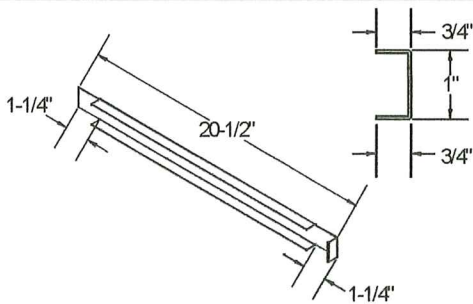

DUCT RAIL TC44ND P4

QTY. (1)

18 Ga. Steel, 33 ksi Min.
G-90 Galvanized per ASTM A653
or Corrosion resistant per FBC, HVHZ

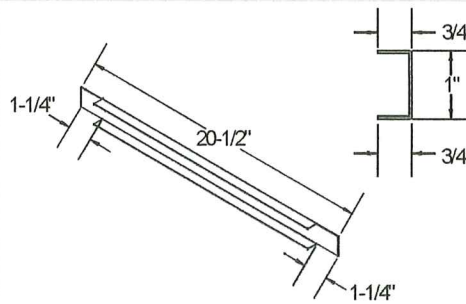

DUCT RAIL TC44ND P5

QTY. (1)

18 Ga. Steel, 33 ksi Min.
G-90 Galvanized per ASTM A653
or Corrosion resistant per FBC, HVHZ

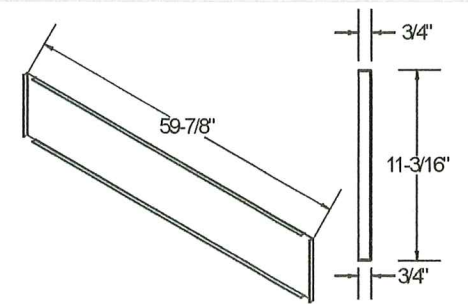

TC44ND P6

QTY. (3)

18 Ga. Steel, 33 ksi Min.
G-90 Galvanized per ASTM A653
or Corrosion resistant per FBC, HVHZ

NOT TO SCALE

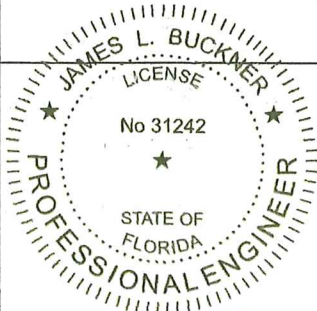

Plenums "TC Series" Trane Roof Curbs
ENGINEERING REPORT

CBUCK Engineering
Specialty Structural Engineering
CBUCK, Inc. COA #8064
www.cbuckinc.net
(561) 491-9927
1374 Community Drive
Jupiter, FL 33458

MANUFACTURER:
Plenums of Florida, Inc.
P.O. Box 1890
Pinellas Park, FL 33780

DATE:	3 / 28 / 16
PAGE #:	11 OF 11
REPORT #:	15-187-TC Series-ER-6th
PROJECT #:	15-187
DRAWN BY:	YD
REVISION :	11/13/2023

J. L. Buckner
11/9/23