



DEPARTMENT OF REGULATORY AND ECONOMIC RESOURCES (RER)  
BOARD AND CODE ADMINISTRATION DIVISION  
**NOTICE OF ACCEPTANCE (NOA)**

MIAMI-DADE COUNTY  
PRODUCT CONTROL SECTION  
11805 SW 26 Street, Room 208  
Miami, Florida 33175-2474  
T (786) 315-2590 F (786) 315-2599  
[www.miamidade.gov/economy](http://www.miamidade.gov/economy)

**Trespa North America, Ltd.**  
**350 Fifth Ave, Ste 4610**  
**New York, NY 10012**

**SCOPE:**

This NOA is being issued under the applicable rules and regulations governing the use of construction materials. The documentation submitted has been reviewed and accepted by Miami-Dade County RER-Product Control Section to be used in Miami Dade County and other areas where allowed by the Authority Having Jurisdiction (AHJ).

This NOA shall not be valid after the expiration date stated below. The Miami-Dade County Product Control Section (In Miami Dade County) and/or the AHJ (in areas other than Miami Dade County) reserve the right to have this product or material tested for quality assurance purposes. If this product or material fails to perform in the accepted manner, the manufacturer will incur the expense of such testing and the AHJ may immediately revoke, modify, or suspend the use of such product or material within their jurisdiction. RER reserves the right to revoke this acceptance if it is determined by Miami-Dade County Product Control Section that this product or material fails to meet the requirements of the applicable building code.

This product is approved as described herein and has been designed to comply with the Florida Building Code, including the High Velocity Hurricane Zone.

**DESCRIPTION: TS 110 Trespa Meteon FR Composite Siding System**

**APPROVAL DOCUMENT:** Drawing No. **08-00605 Rev D**, titled "TS110 Trespa Meteon Decorative Panel System 10 mm and 13 mm", sheets 1 through 6 of 6, prepared by Trespa North America, Ltd, dated 09/15/2008 and last revised on 12/15/23, signed and sealed by Luis R. Lomas, P.E., bearing the Miami-Dade County Product Control renewal stamp with the Notice of Acceptance number and expiration date by the Miami-Dade County Product Control Section.

**MISSILE IMPACT RATING: Large and Small Missile Impact Resistant**

**LABELING:** A permanent label with the manufacturer's name or logo, city, state, model/series, and following statement: "Miami-Dade County Product Control Approved", is to be located on each panel.

**RENEWAL** of this NOA shall be considered after a renewal application has been filed and there has been no change in the applicable building code negatively affecting the performance of this product.

**TERMINATION** of this NOA will occur after the expiration date or if there has been a revision or change in the materials, use, and/or manufacture of the product or process. Misuse of this NOA as an endorsement of any product, for sales, advertising or any other purposes shall automatically terminate this NOA. Failure to comply with any section of this NOA shall be cause for termination and removal of NOA.

**ADVERTISEMENT:** The NOA number preceded by the words Miami-Dade County, Florida, and followed by the expiration date may be displayed in advertising literature. If any portion of the NOA is displayed, then it shall be done in its entirety.

**INSPECTION:** A copy of this entire NOA shall be provided to the user by the manufacturer or its distributors and shall be available for inspection at the job site at the request of the Building Official.

This NOA **revises & renews NOA # 22-0202.07** and consists of this page 1 and evidence pages E-1, E-2, E-3 and E-4, as well as approval document mentioned above.

The submitted documentation was reviewed by **Ishaq I. Chanda, P.E.**



NOA No. 24-0102.02  
Expiration Date: January 8, 2029  
Approval Date: March 21, 2024  
Page 1

**NOTICE OF ACCEPTANCE: EVIDENCE SUBMITTED**

**1. Evidence submitted under previous NOA's**

**A. DRAWINGS “Submitted under NOA # 13-1211.12”**

1. Drawing No. **08-00605**, titled “TS 110 Trespa Meteor Decorative Panel System 10 mm and 13 mm”, sheets 1 through 4 of 4, dated 09/15/08, with revision B dated 12/04/2013, prepared by Trespa North America, Ltd, signed and sealed by Luis R. Lomas, P.E.

**B. TESTS “Submitted under NOA # 08-0922.07”**

1. Test reports on 1) Uniform Static Air Pressure Test, Loading per FBC TAS 202-94  
2) Cyclic Wind Pressure Loading per FBC, TAS 203-94  
along with marked-up drawings and installation diagram of 106”x 52” (10mm thick), 143-1/2”x 73” and 200-3/8”x 80-3/8” (13mm thick) Trespa Meteor Wall Panels, prepared by Hurricane Test Laboratory, LLC, Test Report No. **0358-0411-04**, dated 02/25/2005, signed and sealed by Vinu J. Abraham, P.E.

**C. CALCULATIONS “Submitted under NOA # 14-1022.05”**

1. Anchor verification calculations dated 10/06/2014, prepared, signed and sealed by Luis R. Lomas, P.E.  
  
**“Submitted under NOA # 08-0922.07”**
2. Anchor verification calculations and structural analysis complying with F.B.C 2004, dated 09/15/2008, prepared, signed and sealed by Luis R. Lomas, P.E.

**D. QUALITY ASSURANCE**

1. Miami-Dade Department of Regulatory and Economic Resources (RER)

**E. MATERIAL CERTIFICATIONS “Submitted under NOA # 08-0922.07”**

1. Test report on Exposure per ASTM G7-05 and ASTM G147-02 and on Evaluation per ASTM D714-02, ASTM D2244-05, ASTM E284-02, ASTM D1729-96 (2003), ASTM D661-93 (2005) and ASTM D523-89 (1999) on panel specimens, prepared by South Florida Test Service a division of Atlas Material Testing Technology LLC, Test Report No. **5**, dated 06/09/2007, signed and sealed by Mark Mosbat, P.E.
2. Test report on Maintaining Constant Relative Humidity by Means of Aqueous Solutions per ASTM E 104-02 and Flexural Properties of Unreinforced and Reinforced Plastics and Electrical Insulating Materials per ASTM D 790-07 of 8mm Meteor Panels with Fire Retardant Kraft Paper Core, prepared by Architectural Testing, Inc, Test Report No. **77711.01-106-18**, dated 04/24/2008, signed and sealed by Joseph A. Reed, P.E.
3. Test report on Tensile Properties of Plastics per ASTM D638-02 on controlled and 5-year weathered 8mm Meteor A03.0.0 Fire Retardant Kraft Core Panels, prepared by Architectural Testing, Test Report No. **59371.01-106-31**, dated 11/11/2005, signed by Todd D. Burroughs.

Ishaq I. Chanda

**Ishaq I. Chanda, P.E.**  
**Product Control Unit Supervisor**  
**NOA No. 24-0102.02**  
**Expiration Date: January 8, 2029**  
**Approval Date: March 21, 2024**

**NOTICE OF ACCEPTANCE: EVIDENCE SUBMITTED**

**F. STATEMENTS “Submitted under NOA # 14-1022.05”**

1. Statement letter of code conformance to the 5<sup>th</sup> edition (2014) FBC and no financial interest, dated 10/06/2014, issued, signed and sealed by Luis R. Lomas, P.E.
2. Statement letter of code conformance to 2010 FBC and no financial interest, dated 12/03/2013, issued, signed and sealed by Luis R. Lomas, P.E.  
**“Submitted under NOA # 13-1211.12”**

**2. Evidence submitted under NOA # 19-0417.02**

**A. DRAWINGS**

1. Drawing No. **08-00605**, titled “TS 110 Trespa Meteon Decorative Panel System 10 mm and 13 mm”, sheets 1 through 6 of 6, dated 09/15/2008, with revision C dated 5/30/2019, prepared by Trespa North America, Ltd, signed and sealed by Luis R. Lomas, P.E. on 07/25/2019.

**B. TESTS**

1. None.

**C. CALCULATIONS**

1. Anchor verification calculations prepared by L. Roberto Lomas, P.E., dated 07/26/2019, signed and sealed by Luis R. Lomas, P.E.

**D. QUALITY ASSURANCE**

1. Miami-Dade Department of Regulatory and Economic Resources (RER)

**E. MATERIAL CERTIFICATIONS**

1. None.

**F. STATEMENTS**

1. Statement letter of code conformance to the 6<sup>th</sup> edition (2017) FBC and of no financial interest, dated 05/14/2019, issued by L. Roberto Lomas, P.E., signed and sealed by Luis R. Lomas, P.E.

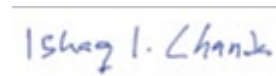

---

**Ishaq I. Chanda, P.E.**  
**Product Control Unit Supervisor**  
**NOA No. 24-0102.02**  
**Expiration Date: January 8, 2029**  
**Approval Date: March 21, 2024**

**NOTICE OF ACCEPTANCE: EVIDENCE SUBMITTED**

**3. Evidence submitted under previous approval**

**A. DRAWINGS**

1. Drawing No. **08-00605**, titled “TS110 Trespa Meteon Decorative Panel System 10 mm and 13 mm”, sheets 1 through 6 of 6, dated 09/15/2008, with revision D dated 12/08/2021, prepared by Trespa North America, Ltd, signed and sealed by Luis R. Lomas, P.E. on 01/12/2022.

**B. TESTS**

1. None.

**C. CALCULATIONS**

1. Anchor verification calculations prepared by L. Roberto Lomas, P.E., dated 12/08/2021, signed and sealed by Luis R. Lomas, P.E.

**D. QUALITY ASSURANCE**

1. Miami-Dade Department of Regulatory and Economic Resources (RER).

**E. MATERIAL CERTIFICATIONS**

1. None.

**F. STATEMENTS**

1. Statement letter of code conformance to the 7<sup>th</sup> edition (2020) of the FBC and of no financial interest, dated 12/08/2021, issued, signed and sealed by Luis R. Lomas, P.E.

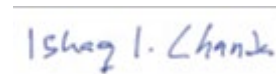

---

**Ishaq I. Chanda, P.E.**  
**Product Control Unit Supervisor**  
**NOA No. 24-0102.02**  
**Expiration Date: January 8, 2029**  
**Approval Date: March 21, 2024**

**NOTICE OF ACCEPTANCE: EVIDENCE SUBMITTED**

**3. New evidence submitted**

**A. DRAWINGS**

1. Drawing No. **08-00605 Rev D**, titled “TS110 Trespa Meteon Decorative Panel System 10 mm and 13 mm”, sheets 1 through 6 of 6, prepared by Trespa North America, Ltd, dated 09/15/2008 and last revised on 12/15/23, signed and sealed by Luis R. Lomas, P.E.

**B. TESTS**

1. None.

**C. CALCULATIONS**

1. None.

**D. QUALITY ASSURANCE**

1. Miami-Dade Department of Regulatory and Economic Resources (RER).

**E. MATERIAL CERTIFICATIONS**

1. None.

**F. STATEMENTS**

1. Statement letter of code conformance to the 8<sup>th</sup> edition (2023) of the FBC and of no financial interest, dated 12/15/2023, issued, signed and sealed by Luis R. Lomas, P.E.
2. Email dated 03/07/24 from Luis R. Lomas, P.E., stating that only FBC notes have been updated.

**G. OTHER**

1. This NOA revises & renews NOA # **22-0202.07**, updates to FBC 2023, expiring 01/08/2029.

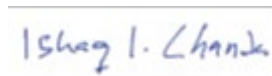

---

**Ishaq I. Chanda, P.E.**  
**Product Control Unit Supervisor**  
**NOA No. 24-0102.02**  
**Expiration Date: January 8, 2029**  
**Approval Date: March 21, 2024**

REVISIONS			
REV	DESCRIPTION	DATE	APPROVED
D	REVISED TO COMPLY WITH NEW CODE	12/15/23	R.L.

NOTES:

- THE PRODUCT SHOWN HEREIN IS DESIGNED AND MANUFACTURED TO COMPLY WITH REQUIREMENTS OF THE 2023 FLORIDA BUILDING CODE 8TH EDITION.
- METAL FRAMING AND MASONRY OPENING TO BE DESIGNED AND ANCHORED TO PROPERLY TRANSFER ALL LOADS TO STRUCTURE. FRAMING AND MASONRY OPENING IS THE RESPONSIBILITY OF THE ARCHITECT OR ENGINEER OF RECORD.
- CONTRACTOR IS RESPONSIBLE FOR MAINTAINING STRUCTURAL INTEGRITY OF WINDOW OPENING AND ALL WOOD FRAMING AROUND WINDOW.
- FOR INSTALLATION INTO PLYWOOD SHEATHING USE 1/4" LAG BOLT WITH SUFFICIENT LENGTH TO ACHIEVE A 5/8" MINIMUM EMBEDMENT INTO SUBSTRATE. LOCATE ANCHORS AS SHOWN IN ELEVATIONS AND INSTALLATION DETAILS.
- FOR INSTALLATION INTO MASONRY/CONCRETE WALL USE 1/4" ITW TAPCON WITH SUFFICIENT LENGTH TO ACHIEVE A 1 1/4" MINIMUM EMBEDMENT INTO SUBSTRATE. LOCATE ANCHORS AS SHOWN IN ELEVATIONS AND INSTALLATION DETAILS.
- ALL FASTENERS TO BE CORROSION RESISTANT.
- INSTALLATION ANCHORS SHALL BE INSTALLED IN ACCORDANCE WITH ANCHOR MANUFACTURER'S INSTALLATION INSTRUCTIONS, AND ANCHORS SHALL NOT BE USED IN SUBSTRATES WITH STRENGTHS LESS THAN THE MINIMUM STRENGTH SPECIFIED BELOW:
  - STEEL STUDS 16GA Fy=33KSI, Fu=52KSI
  - CONCRETE - MINIMUM COMPRESSIVE STRENGTH OF 3,200 PSI.
  - MASONRY - STRENGTH CONFORMANCE TO ASTM C-90, GRADE N, TYPE 1 (OR GREATER)
- ALLOWABLE STRESS INCREASE OF 1/3 WAS NOT USED IN THE DESIGN OF THE PRODUCT SHOWN HEREIN. WIND LOAD DURATION FACTOR Cd=1.6 WAS USED FOR WOOD ANCHOR CALCULATIONS.
- PANEL MATERIAL: TRESPA METEON KRAFT FR CORE PANEL 10MM AND 13MM THICK. MATERIAL IS BASED ON THERMOSETTING RESINS HOMOGENOUSLY REINFORCED WITH WOOD FIBERS AND MANUFACTURED UNDER PRESSURE AND TEMPERATURE. PANEL CONSISTS OF 70% SOFTWOOD FIBERS AND 30% THERMOSETTING RESINS. THERMOSETTING RESINS ARE CURED USING ELECTRON RAYS (ELECTRON BEAM CURING) PROCESS DEVELOPED BY TRESPA NORTH AMERICA, LTD.

- EXTRUSION MATERIAL: ALUMINUM 6063-T6.
- THIS PRODUCT SHALL BE INSTALLED ONTO EXISTING APPROVED WALLS CONSISTING OF CONCRETE, C-90 CONCRETE BLOCK OR 5/8" MIN. PLYWOOD SHEATHING. ATTACHED TO 2X STEEL STUD AT 16" MAX. O.C.
- WATER RESISTIVE BARRIER PER FLORIDA BUILDING CODE SECTION 1404.2

**PRODUCT RENEWED**  
 as complying with the Florida  
 Building Code  
 NOA-No. 24-0102.02  
 Expiration Date 01/08/2029  
 By Ishaq I. Chande  
 Miami-Dade Product Control

SIGNED: 12/15/2023

TABLE OF CONTENTS	
SHEET NO.	DESCRIPTION
1	NOTES
2 - 3	ELEVATIONS
4 - 5	INSTALLATION DETAILS
6	COMPONENTS

<b>TRESPA NORTH AMERICA</b> 10155 READING RD CINCINNATI, OH 45241		
<b>TS110 TRESPA METEON DECORATIVE PANEL SYSTEM</b> 10MM AND 13MM NOTES		
DRAWN: R.L.	DWG NO. 08-00605	REV D
SCALE NTS	DATE 09/15/08	SHEET 1 OF 6
<small>L. ROBERTO LOMAS P.E.          208 7th AVENUE, INDIAN LANTIC, FL 32903          434-688-0609 rllomas@rlomaspe.com</small>		

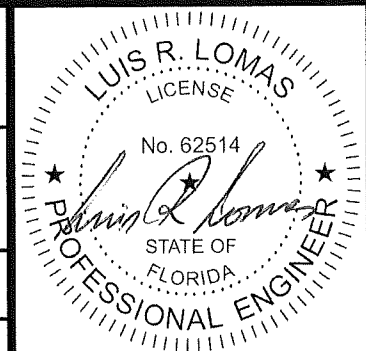

Luis R. Lomas P.E.  
 FL No.: 62514

REVISIONS			
REV	DESCRIPTION	DATE	APPROVED
D	REVISED TO COMPLY WITH NEW CODE	12/15/23	R.L.

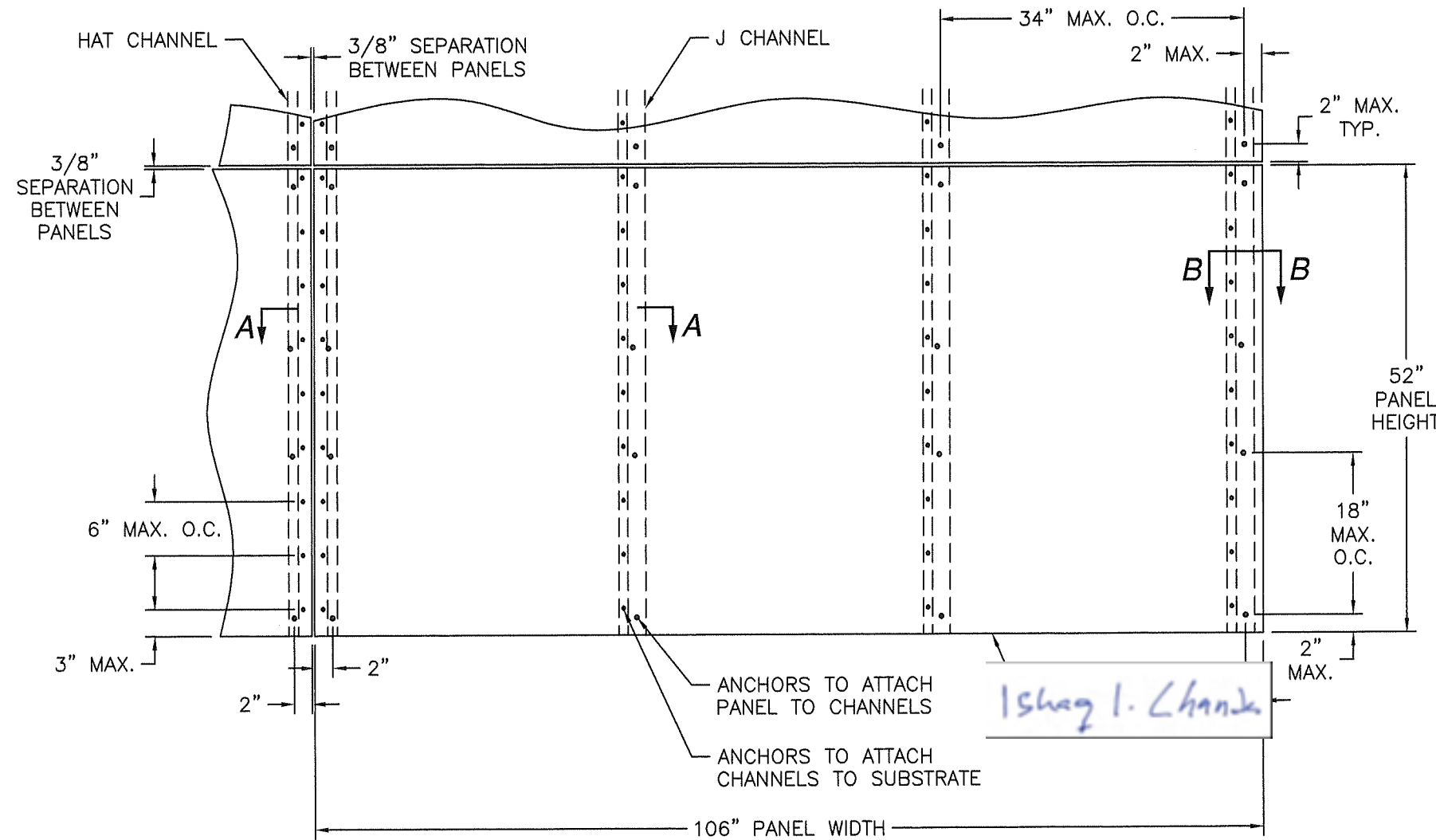

**PRODUCT RENEWED**  
 as complying with the Florida  
 Building Code  
 NOA-No. 24-0102.02  
 Expiration Date 01/08/2029  
 By Ishag I. Chank  
 Miami-Dade Product Control

**TS110 10MM PANEL**  
 INSTALLATION ELEVATION

DESIGN PRESSURE RATING	IMPACT RATING
±75.0PSF	LARGE MISSILE IMPACT

106" x 52" PANEL SHOWN. OTHER PANEL SIZES ARE QUALIFIED AS LONG AS PANEL AREA DOES NOT EXCEED 72.5 FT<sup>2</sup>

SIGNED: 12/15/2023

TRESPA NORTH AMERICA  
 10155 READING RD  
 CINCINNATI, OH 45241

TS110 TRESPA METEON DECORATIVE PANEL SYSTEM  
 10MM AND 13MM  
 10MM ELEVATION

DRAWN: R.L. DWG NO. 08-00605 REV D

SCALE NTS DATE 09/15/08 SHEET 2 OF 6

L. ROBERTO LOMAS P.E.  
 208 7th AVENUE, INDIANLANTIC, FL 32903  
 434-688-0609 rllomas@rlomaspe.com

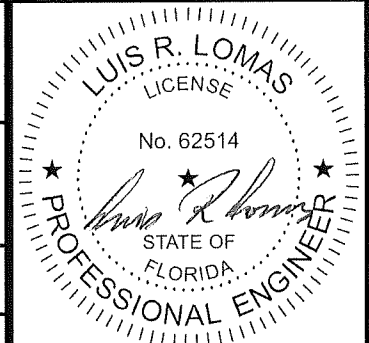

Luis R. Lomas P.E.  
 FL No.: 62514

REVISIONS			
REV	DESCRIPTION	DATE	APPROVED
D	REVISED TO COMPLY WITH NEW CODE	12/15/23	R.L.

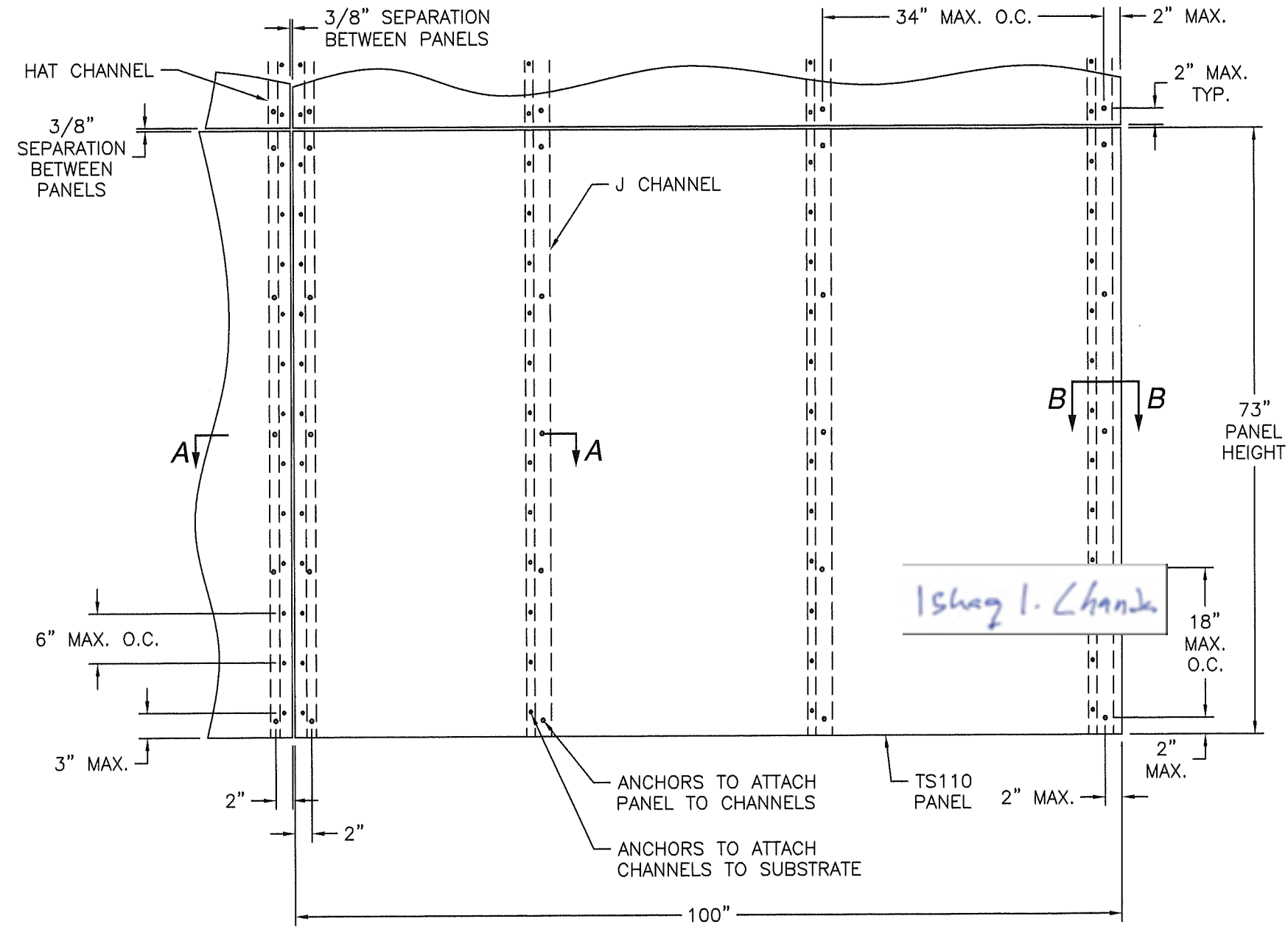

**PRODUCT RENEWED**  
 as complying with the Florida  
 Building Code  
 NOA-No. 24-0102.02  
 Expiration Date 01/08/2029  
 By Ishag I. Chank  
 Miami-Dade Product Control

*Ishag I. Chank*

**TS110 13MM PANEL**  
 INSTALLATION ELEVATION

DESIGN PRESSURE RATING	IMPACT RATING
±75.0PSF	LARGE MISSILE IMPACT

106" x 52" PANEL SHOWN. OTHER PANEL SIZES ARE QUALIFIED AS LONG AS PANEL AREA DOES NOT EXCEED 72.5 FT<sup>2</sup>

SIGNED: 12/15/2023

**TRESPA NORTH AMERICA**

10155 READING RD  
 CINCINNATI, OH 45241

TS110 TRESPA METEON DECORATIVE PANEL SYSTEM  
 10MM AND 13MM  
 13MM ELEVATION

DRAWN: R.L. DWG NO. 08-00605 REV D

SCALE NTS DATE 09/15/08 SHEET 3 OF 6

L. ROBERTO LOMAS P.E.  
 208 7th AVENUE, INDIANLANTIC, FL 32903  
 434-688-0609 rllomas@lrlomaspe.com

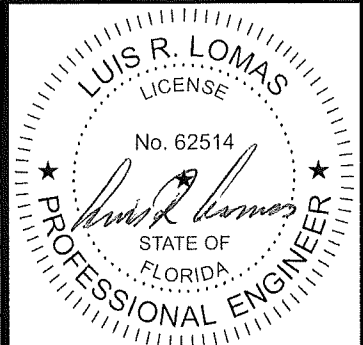

Luis R. Lomas P.E.  
 FL No.: 62514



REVISIONS			
REV	DESCRIPTION	DATE	APPROVED
D	REVISED TO COMPLY WITH NEW CODE	12/15/23	R.L.

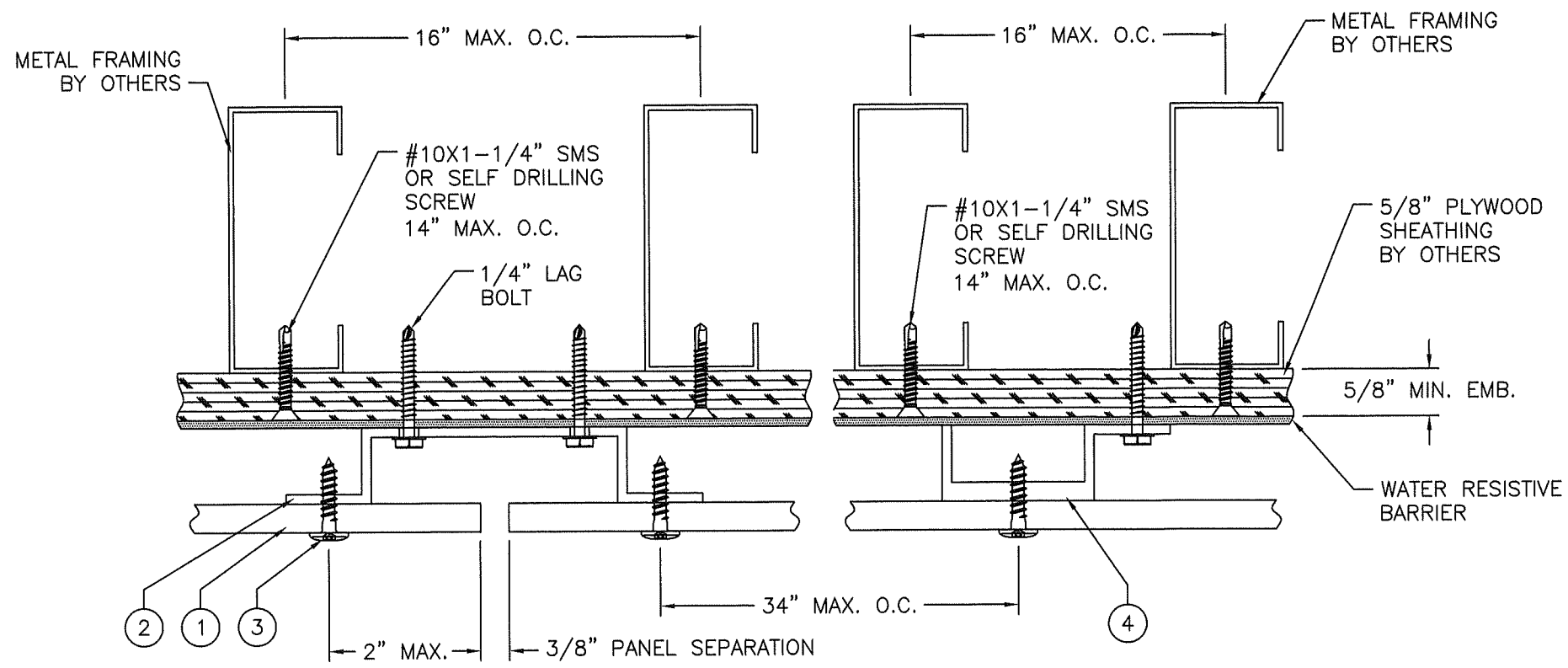

**SECTION A-A INSTALLATION DETAIL**  
5/8" PLYWOOD SHEATHING INSTALLATION (METAL FRAMING)

**PRODUCT RENEWED**  
as complying with the Florida  
Building Code  
NOA-No. 24-0102.02  
Expiration Date 01/08/2029  
By Isaac I. Chank  
Miami-Dade Product Control

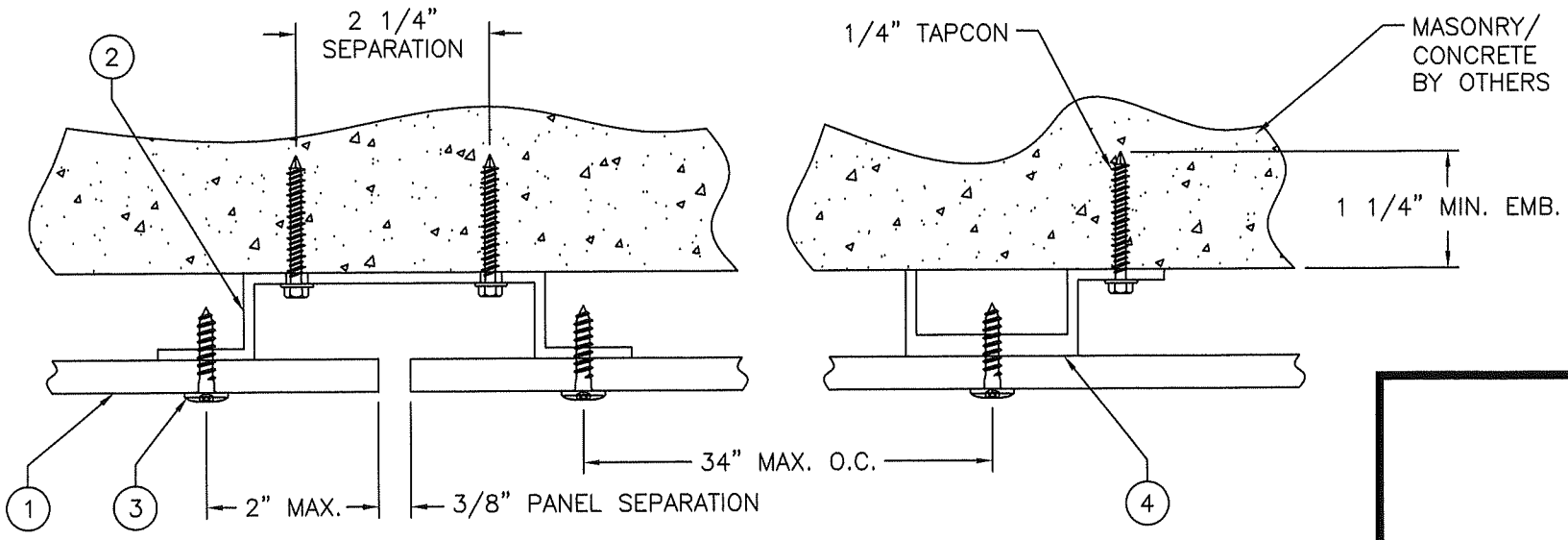

**SECTION A-A INSTALLATION DETAIL**  
MASONRY/CONCRETE

SIGNED: 12/15/2023

**TRESPA NORTH AMERICA**  
10155 READING RD  
CINCINNATI, OH 45241

**TS110 TRESPA METEON DECORATIVE PANEL SYSTEM**  
10MM AND 13MM  
INSTALLATION DETAILS

DRAWN: R.L.	DWG NO. 08-00605	REV D
SCALE NTS	DATE 09/15/08	SHEET 4 OF 6

L. ROBERTO LOMAS P.E.  
208 7th AVENUE, INDIALANTIC, FL 32903  
434-688-0609 rllomas@lrlomaspe.com

**LUIS R. LOMAS**  
LICENSE  
No. 62514  
STATE OF  
FLORIDA  
PROFESSIONAL ENGINEER

**Luis R. Lomas P.E.**  
FL No.: 62514

REVISIONS			
REV	DESCRIPTION	DATE	APPROVED
D	REVISED TO COMPLY WITH NEW CODE	12/15/23	R.L.

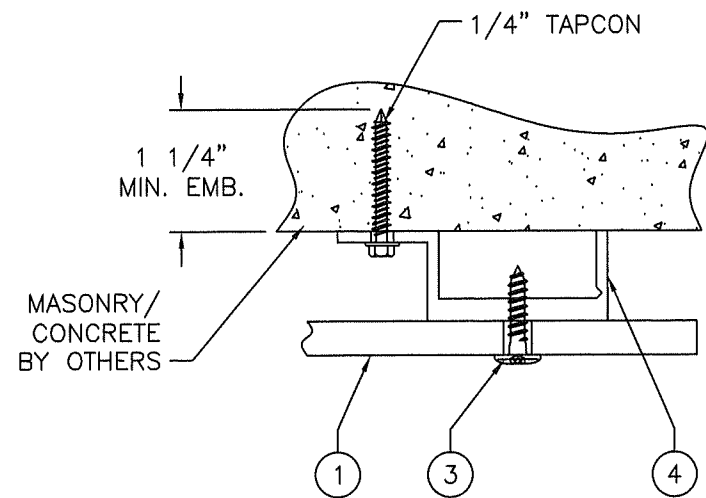

**SECTION B-B INSTALLATION DETAIL**  
MASONRY/CONCRETE

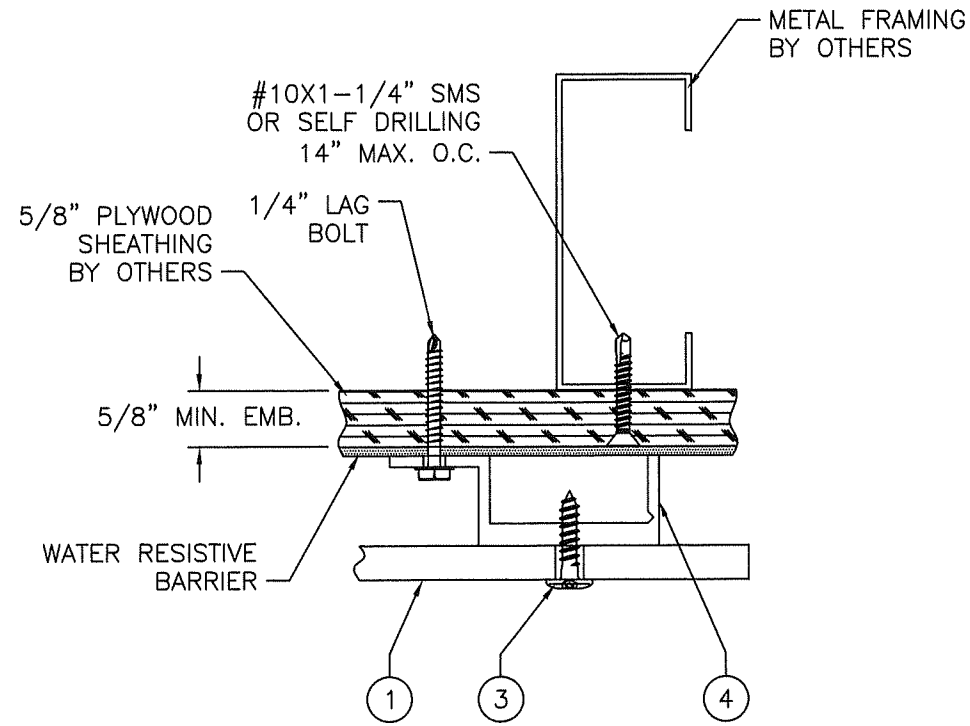

**SECTION B-B INSTALLATION DETAIL**  
5/8" PLYWOOD SHEATHING INSTALLATION (METAL FRAMING)

**PRODUCT RENEWED**  
as complying with the Florida  
Building Code  
NOA-No. 24-0102.02  
Expiration Date 01/08/2029  
By *Ishaq I. Chande*  
Miami-Dade Product Control

SIGNED: 12/15/2023

<b>TRESPA NORTH AMERICA</b> 10155 READING RD CINCINNATI, OH 45241			
<b>TS110 TRESPA METEON DECORATIVE PANEL SYSTEM</b> 10MM AND 13MM INSTALLATION DETAILS			
DRAWN: R.L.	DWG NO. 08-00605	REV D	
SCALE NTS	DATE 09/15/08	SHEET 5 OF 6	
L. ROBERTO LOMAS P.E. 208 7th AVENUE, INDIANLANTIC, FL 32903 434-688-0609 rllomas@rlomaspe.com			Luis R. Lomas P.E. FL No.: 62514

REVISIONS			
REV	DESCRIPTION	DATE	APPROVED
D	REVISED TO COMPLY WITH NEW CODE	12/15/23	R.L.

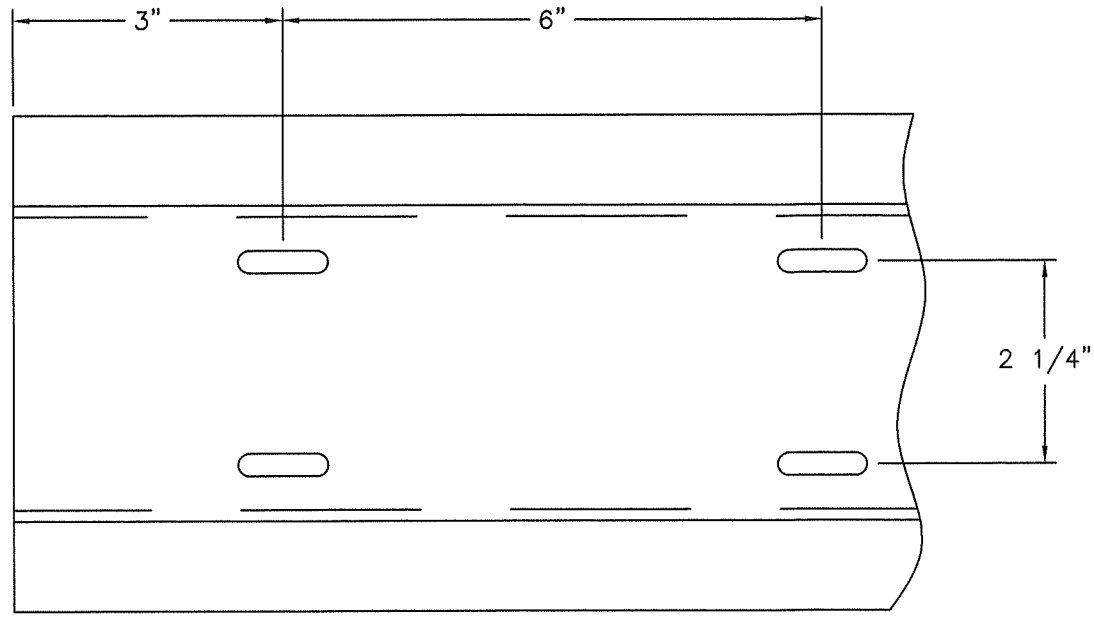
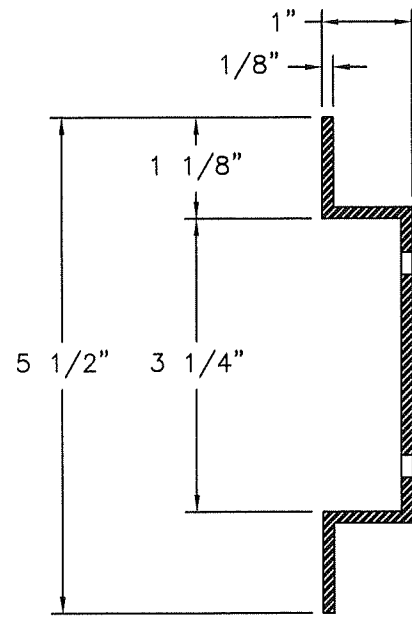

② **HAT CHANNEL**  
ALUMINUM 6063-T6 .125" THICK  
10' MAX. LENGTH

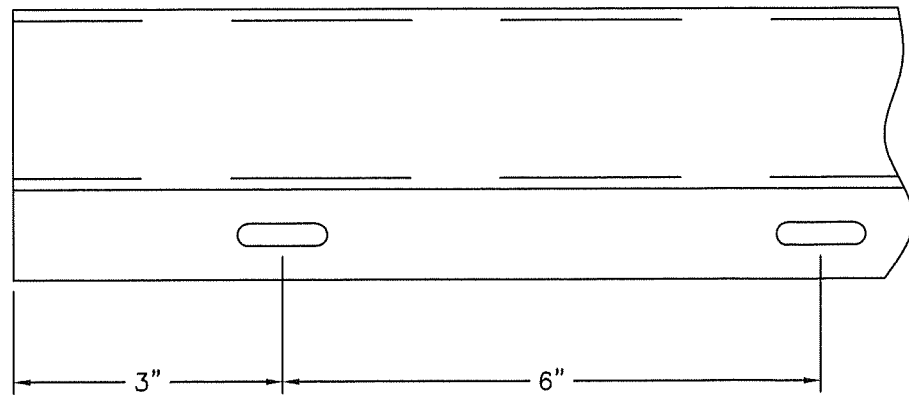
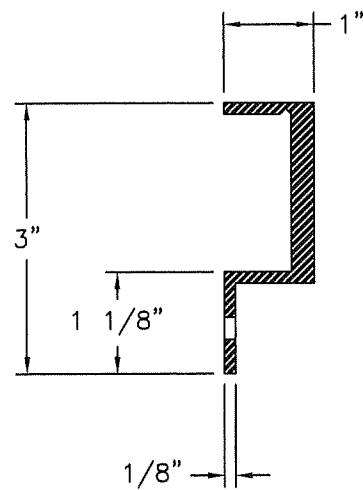

④ **J CHANNEL**  
ALUMINUM 6063-T6 .125" THICK  
10' MAX. LENGTH

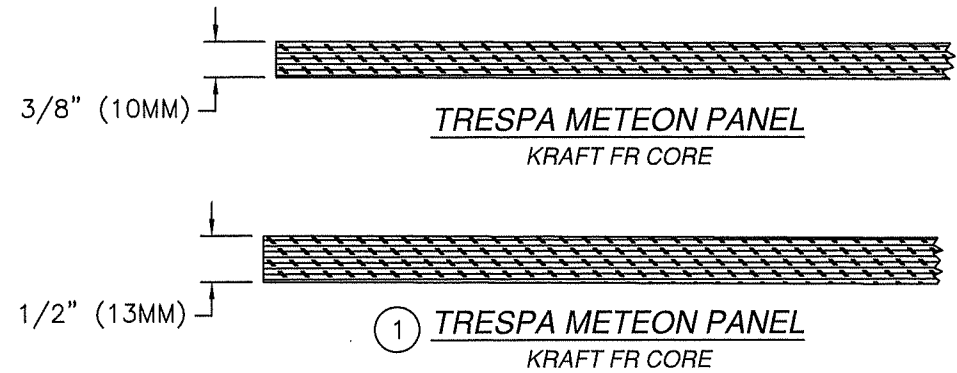

**PRODUCT RENEWED**  
as complying with the Florida  
Building Code  
NOA-No. 24-0102.02  
Expiration Date 01/08/2029  
By *Ishaq I. Chande*  
Miami-Dade Product Control

SIGNED: 12/15/2023

PARTS LIST				
NO.	PART NUMBER	DESCRIPTION	MANUFACTURER	MATERIAL
1	TS110	METEON PANEL 10MM & 13MM	TRESPA NA	
2	110-001	HAT CHANNEL	SIERRA ALUMINUM	6063-T6
3	100-000	#12-11X1.15" PANEL FASTENER	SFS INTEC	SST
4	110-000	J CHANNEL	SIERRA ALUMINUM	6063-T6

<b>TRESPA NORTH AMERICA</b> 10155 READING RD CINCINNATI, OH 45241		
<b>TS110 TRESPA METEON DECORATIVE PANEL SYSTEM</b> 10MM AND 13MM COMPONENTS		
DRAWN: R.L.	DWG NO. 08-00605	REV D
SCALE NTS	DATE 09/15/08	SHEET 6 OF 6
L. ROBERTO LOMAS P.E. 208 7th AVENUE, INDIANLANTIC, FL 32903 434-688-0609 rllomas@lrlomaspe.com		

LUIS R. LOMAS  
 LICENSE  
 No. 62514  
*Luis R. Lomas*  
 STATE OF  
 FLORIDA  
 PROFESSIONAL ENGINEER

Luis R. Lomas P.E.  
 FL No.: 62514