



DEPARTMENT OF REGULATORY AND ECONOMIC RESOURCES (RER)
 BOARD AND CODE ADMINISTRATION DIVISION
NOTICE OF ACCEPTANCE (NOA)

MIAMI-DADE COUNTY
 PRODUCT CONTROL SECTION
 11805 SW 26 Street, Room 208
 Miami, Florida 33175-2474
 T (786) 315-2590 F (786) 315-2599
www.miamidade.gov/economy

C & C North America, Inc.
dba Cosentino, North America
355 Alhambra Circle, suite 1000
Coral Gables, Florida 33134

SCOPE: This NOA is being issued under the applicable rules and regulations governing the use of construction materials. The documentation submitted has been reviewed and accepted by Miami-Dade County RER-Product Control Section to be used in Miami Dade County and other areas where allowed by the Authority Having Jurisdiction (AHJ).

This NOA shall not be valid after the expiration date stated below. The Miami-Dade County Product Control Section (In Miami Dade County) and/or the AHJ (in areas other than Miami Dade County) reserve the right to have this product or material tested for quality assurance purposes. If this product or material fails to perform in the accepted manner, the manufacturer will incur the expense of such testing and the AHJ may immediately revoke, modify, or suspend the use of such product or material within their jurisdiction. RER reserves the right to revoke this acceptance, if it is determined by Miami-Dade County Product Control Section that this product or material fails to meet the requirements of the applicable building code.

This product is approved as described herein and has been designed to comply with the Florida Building Code, including the High Velocity Hurricane Zone.

DESCRIPTION: Series “Dekton” Ultra Compact Composite Panel-NI

APPROVAL DOCUMENT: Drawing No. **18-122 Rev C**, titled “Dekton Ultra Compact Panel Façade System (NI)”, sheets 1 through 11 of 11, prepared by Al-Farooq Corporation dated 09-19-19 and last revised on JAN 22, 2024, signed and sealed by Jalal Farooq, P.E., bearing the Miami-Dade County Product Control Renewal stamp with the Notice of Acceptance number and Approval date by the Miami-Dade County Product Control Section.

MISSILE IMPACT RATING: Large and Small Missile Resistant

Limitations:

1. Panel-1 type can be installed in wood, masonry/concrete or metal structures.
2. Panel -1A can only be installed on masonry/concrete substrates, using ARDX X-77 mortar chemical adhesive.
3. Applicable Fire distance required to be reviewed by AHJ.

LABELING: Each unit shall bear a permanent label with the manufacturer's name or logo, city, state, Model/series, and following statement: "Miami-Dade County Product Control Approved", unless otherwise noted herein.

RENEWAL of this NOA shall be considered after a renewal application has been filed and there has been no change in the applicable building code negatively affecting the performance of this product.

TERMINATION of this NOA will occur after the expiration date or if there has been a revision or change in the materials, use, and/or manufacture of the product or process. Misuse of this NOA as an endorsement of any product, for sales, advertising or any other purposes shall automatically terminate this NOA. Failure to comply with any section of this NOA shall be cause for termination and removal of NOA.

ADVERTISEMENT: The NOA number preceded by the words Miami-Dade County, Florida, and followed by the expiration date may be displayed in advertising literature. If any portion of the NOA is displayed, then it shall be done in its entirety.

INSPECTION: A copy of this entire NOA shall be provided to the user by the manufacturer or its distributors and shall be available for inspection at the job site at the request of the Building Official.

This NOA **revises & renews # 21-107.02** consists of this page 1 and evidence pages E-1, E-2 and E-3, as well as

approval document mentioned above. Ishag I. Chande



NOA No. 24-0123.03
Expiration Date: May 30, 2029
Approval Date: March 28, 2024
 Page 1

NOTICE OF ACCEPTANCE: EVIDENCE SUBMITTED

1. EVIDENCE SUBMITTED

A. DRAWINGS

1. Drawing No. **18-122 Rev, A**, titled “Dekton Ultra Compact Panel Façade System (NI)”, sheets 1 through 11 of 11, prepared by Al-Farooq Corporation dated 09-19-19 and last revised on May 14, 2019, signed and sealed by Javad Ahmad, P.E.

B. TESTS

1. Test reports on 1) Uniform Static Air Pressure Test, Loading per FBC TAS 202-94
2) Cyclic Wind Pressure Loading per FBC, TAS 203-94
along with marked-up drawings of ultra compact composite panels façade system, prepared by Fenestration Testing Lab, Test Report No. **FTL 1019**, dated 07/16/2018, signed and sealed by Idalmis Ortega, P.E.

	<u>Test Report</u>	<u>Test Standard</u>	<u>Date</u>	<u>Signature</u>
2.	RJ4293-1	ASTE-84-15b	02/22/18	V. Andrew Tan, P.E.
3.	RJ3649	ASTM C-1026-13	09/12/18	V. Andrew Tan, P.E.
4.	RJ4293PT-4	ASTM C373	07/11/16	Chris Taylor

C. CALCULATIONS

1. Anchor verification calculations prepared by Al-Farooq Corporation, dated 12//11/2018 and last revised on 04/11/19, signed and sealed by Javad Ahmad, P.E.

D. QUALITY ASSURANCE

1. Miami-Dade Department of Regulatory and Economic Resources (RER).

E. MATERIAL CERTIFICATIONS

1. None.

F. STATEMENTS

1. Statement letter of code conformance to the 6th edition (2017) FBC, issued by Al-Farooq Corporation, dated 04/24/2019, signed and sealed by Javad Ahmad, P.E.

G. OTHER

1. Test proposal #**17-0366** dated May 05, 2017, approved by Carlos Utrera, P.E.
2. State of Delaware listing of C & C North America, Inc, incorporated under the law of State of Delaware and C& C North America, Inc., doing business as Cosentino North America Corp having full ownership in Cosentino S.A.U. (incorporated under the law of Spain), signed by Jeffery W. Bullock, Secretary of State.
3. Florida State, Division of Corporation active status listing of Cosentino North America, as active fictitious name listing, Under C & C North America, Inc.
4. Ardex Adhesive and mortars brochures.

Ishaq I. Chanda

Ishaq I. Chanda, P.E.
Product Control Unit Supervisor
NOA No. 24-0123.03
Expiration Date: May 30, 2029
Approval Date: March 28, 2024

C & C North America, Inc.
dba Cosentino, North America

NOTICE OF ACCEPTANCE: EVIDENCE SUBMITTED

2. EVIDENCE SUBMITTED

A. DRAWINGS

1. Drawing No. **18-122 Rev B**, titled “Dekton Ultra Compact Panel Façade System (NI)”, sheets 1 through 11 of 11, prepared by Al-Farooq Corporation dated 09-19-19 and last revised on OCT 05, 2021, signed and sealed by Jalal Farooq, P.E.

B. TESTS

1. None

C. CALCULATIONS

1. Anchor verification calculations, complying w/ FBC 2020, prepared by Al-Farooq Corporation, dated 12//11/2018 and last revised on 10/06/21, signed and sealed by Jalal Farooq, P.E.

D. QUALITY ASSURANCE

1. Miami-Dade Department of Regulatory and Economic Resources (RER).

E. MATERIAL CERTIFICATIONS

1. None.

F. STATEMENTS

1. Statement letter of code conformance to the FBC 7th edition (2020), issued by Al-Farooq Corporation, dated 10/06/21, signed and sealed by Jalal Farooq, P.E.

G. OTHER

1. This NOA **revises # 19-0227.01**, expiring 05/30/2024.
2. State of Delaware listing of C & C North America, Inc, incorporated under the law of State of Delaware and C& C North America, Inc., doing business as Cosentino North America Corp having full ownership in Cosentino S.A.U. (incorporated under the law of Spain), signed by Jeffery W. Bullock, Secretary of State (submitted under **19-0227.01**)
3. Florida State, Division of Corporation active status listing of Cosentino North America, as active fictitious name listing, Under C & C North America, Inc.
4. Ardex Adhesive and mortars brochures.

Ishaq I. Chanda

Ishaq I. Chanda, P.E.
Product Control Unit Supervisor
NOA No. 24-0123.03
Expiration Date: May 30, 2029
Approval Date: March 28, 2024

NOTICE OF ACCEPTANCE: EVIDENCE SUBMITTED

3. New EVIDENCE SUBMITTED

A. DRAWINGS

1. Drawing No. **18-122 Rev C**, titled “Dekton Ultra Compact Panel Façade System (NI)”, sheets 1 through 11 of 11, prepared by Al-Farooq Corporation dated 09-19-19 and last revised on JAN 22, 2024, signed and sealed by Jalal Farooq, P.E.

B. TESTS

1. None

C. CALCULATIONS

1. None.

D. QUALITY ASSURANCE

1. Miami-Dade Department of Regulatory and Economic Resources (RER).

E. MATERIAL CERTIFICATIONS

1. None.

F. STATEMENTS

1. Statement letter of code conformance to the FBC 8th edition (2023) and request renewal with no change, issued by Al-Farooq Corporation, dated 01/19/24, signed and sealed by Jalal Farooq, P.E.

G. OTHER (Note: items 2- 4 were submitted under previous approval)

1. This NOA **revises & renews # 21-1007.02**, expiring 05/30/2029.
2. State of Delaware listing of C & C North America, Inc, incorporated under the law of State of Delaware and C& C North America, Inc., doing business as Cosentino North America Corp having full ownership in Cosentino S.A.U. (incorporated under the law of Spain), signed by Jeffery W. Bullock, Secretary of State (submitted under **19-0227.01**)
3. Florida State, Division of Corporation active status listing of Cosentino North America, as active fictitious name listing, Under C & C North America, Inc.
4. Ardex Adhesive and mortars brochures.

Ishaq I. Chanda

Ishaq I. Chanda, P.E.
Product Control Unit Supervisor
NOA No. 24-0123.03
Expiration Date: May 30, 2029
Approval Date: March 28, 2024

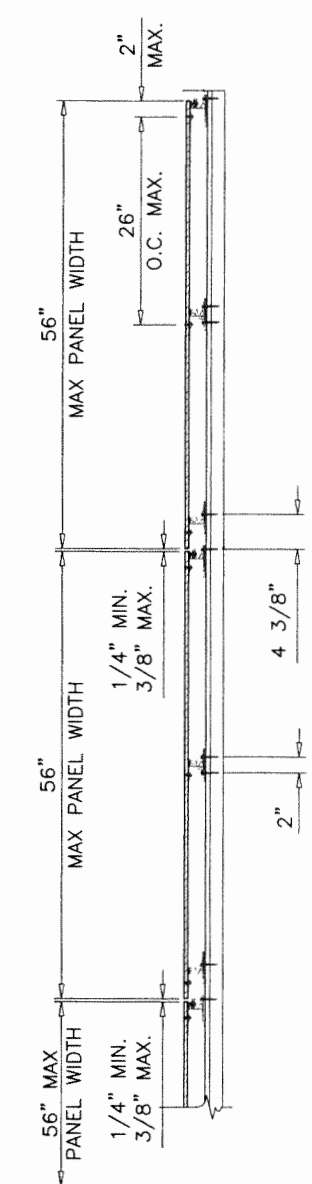
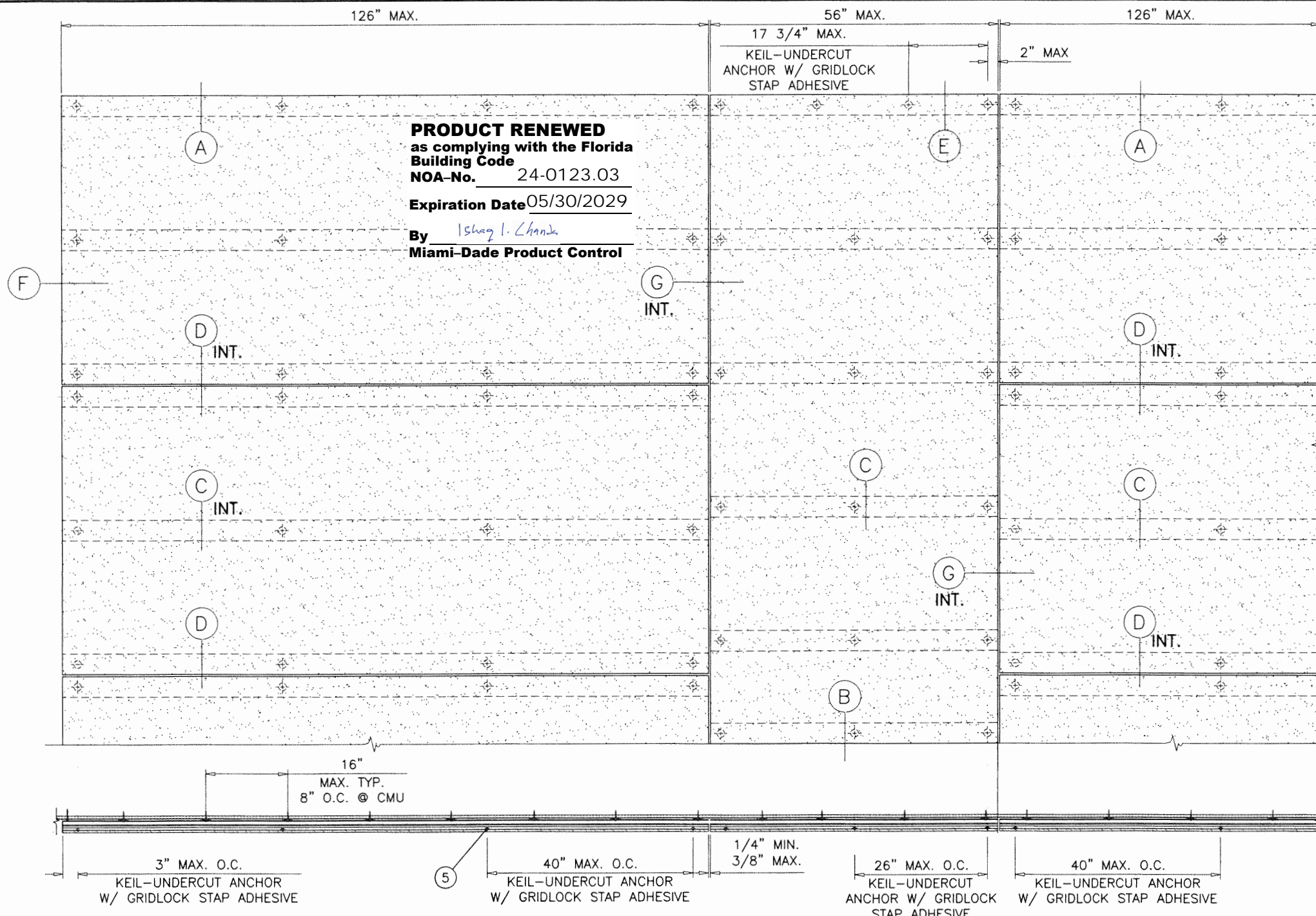

PANEL-1 TYPICAL ELEVATION
 INSTALLATIONS AT WOOD STRUCTURES
 SEE SHEETS 3 AND 4 FOR INSTALLATION DETAILS
 INSTALLATIONS AT METAL STRUCTURES
 SEE SHEETS 5 AND 6 FOR INSTALLATION DETAILS
 INSTALLATIONS AT MASONRY/CONCRETE STRUCTURES
 SEE SHEETS 7 AND 8 FOR INSTALLATION DETAILS

NOTE:
 WIDTH AND LENGTH DIMENSIONS CAN BE ORIENTED
 VERTICALLY OR HORIZONTALLY AS SHOWN ABOVE.

NON IMPACT

SYSTEM IS SECURED TO SHEAR WALLS
 (BY OTHERS) AS EXTERIOR CLADDING

COSENTINO®
1.2cm (.471") & 8mm (.315") DEKTON
ULTRA COMPACT PANEL FACADE SYSTEM

APPROVAL APPLIES TO MULTIPLE UNIT INSTALLATIONS
 MAX. DESIGN LOAD = +125.0 PSF
 -125.0 PSF

MAX. PANEL SIZE = 126" LONG X 56" WIDE
 HORIZONTAL TRACK SPACING = 26" O.C.

THIS PRODUCT HAS BEEN DESIGNED AND TESTED TO COMPLY WITH THE REQUIREMENTS OF THE 2023 (8TH EDITION) FLORIDA BUILDING CODE INCLUDING HIGH VELOCITY HURRICANE ZONE (HVHZ).

COMPOSITE PANEL-1 FACADE SHALL BE INSTALLED IN FRONT OF CBS CONSTRUCTION (ASTM-90) OR CONCRETE STRUCTURE OR 5/8" DENSGLASS BOARD SUPPORTED BY 2X6 STUD OR 2X6- 14 GA METAL STUD AT 16" O.C. DENSGLASS BOARD SHALL BE ATTACHED TO FRAMING STUD IN ACCORDANCE WITH F.B.C. (HVHZ)

ALTERNATE COMPOSITE PANEL-1A FACADE SHALL ONLY BE INSTALLED IN FRONT OF CBS CONSTRUCTION (ASTM-90) OR CONCRETE STRUCTURE, FULLY COVERED WITH ARDEX X-77 MORTAR. USE SHEET 9 AND 10.

APPLICABLE FIRE SEPARATION DISTANCE TO BE REVIEWED BY AHJ.

ANCHORS SHALL BE CORROSION RESISTANT, SPACED AS SHOWN ON DETAILS AND INSTALLED PER MANUF'S INSTRUCTIONS. SPECIFIED EMBEDMENT TO BASE MATERIAL SHALL BE BEYOND WALL DRESSING OR STUCCO.

ALL SHIMS TO BE HIGH IMPACT, NON-METALLIC AND NON-COMPRESSIBLE.

MATERIALS INCLUDING BUT NOT LIMITED TO STEEL/METAL SCREWS, THAT COME INTO CONTACT WITH OTHER DISSIMILAR MATERIALS SHALL MEET THE REQUIREMENTS OF THE 2023 FLORIDA BUILDING CODE & ADOPTED STANDARDS.

THIS PRODUCT APPROVAL IS GENERIC AND DOES NOT PROVIDE INFORMATION FOR A SITE SPECIFIC PROJECT, I.E. LIFE SAFETY OF THIS PRODUCT, ADEQUACY OF STRUCTURE RECEIVING THIS PRODUCT AND SEALING AROUND OPENING FOR WATER INFILTRATION RESISTANCE ETC. CONDITIONS NOT SHOWN IN THIS DRAWING ARE TO BE ANALYZED SEPARATELY, AND TO BE REVIEWED BY BUILDING OFFICIAL.

DESIGN LOADS SHOWN ARE BASED ON 'ALLOWABLE STRESS DESIGN (ASD)'.

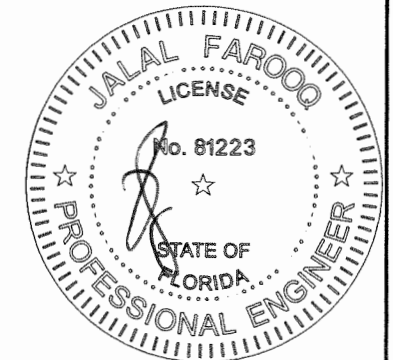

JAN 2 2 2024

AL-FAROOQ CORPORATION
 ENGINEERS & PRODUCT DEVELOPMENT
 9360 SUNSET DRIVE, SUITE 220
 MIAMI, FLORIDA 33173 (C.A.N. 3538)
 TEL. (305) 264-8100 FAX. (305) 262-6978

DEKTON ULTRA COMPACT PANEL FACADE SYSTEM (N.I.)
C&C NORTH AMERICA, INC. dba
COSENTINO NORTH AMERICA.
 355 ALHAMBRA CIRCLE, SUITE 1000
 CORAL GABLES, FL 33134
 PHONE: (786) 686-5060

no	date	description	by
A	05.14.19	REV. PER RER COMMENTS	
B	10.05.21	2020 FBC UPDATE	
C	01.19.24	UPDATED TO 2023 FBC	

date: 09-19-18
 scale: 1/2"=1'-0"
 dr. by: MLS
 chk. by:

drawing no.
18-122
 sheet 1 of 11

126" MA **PRODUCT RENEWED**
 as complying with the Florida
 Building Code
 NOA-No. 24-0123.03
 Expiration Date 05/30/2029
 By Ishaq I. Chande
 Miami-Dade Product Control

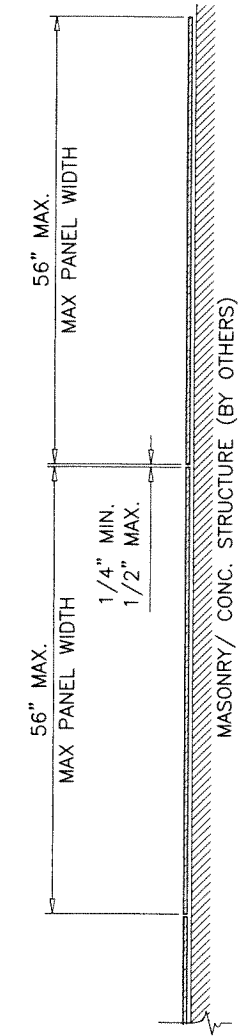
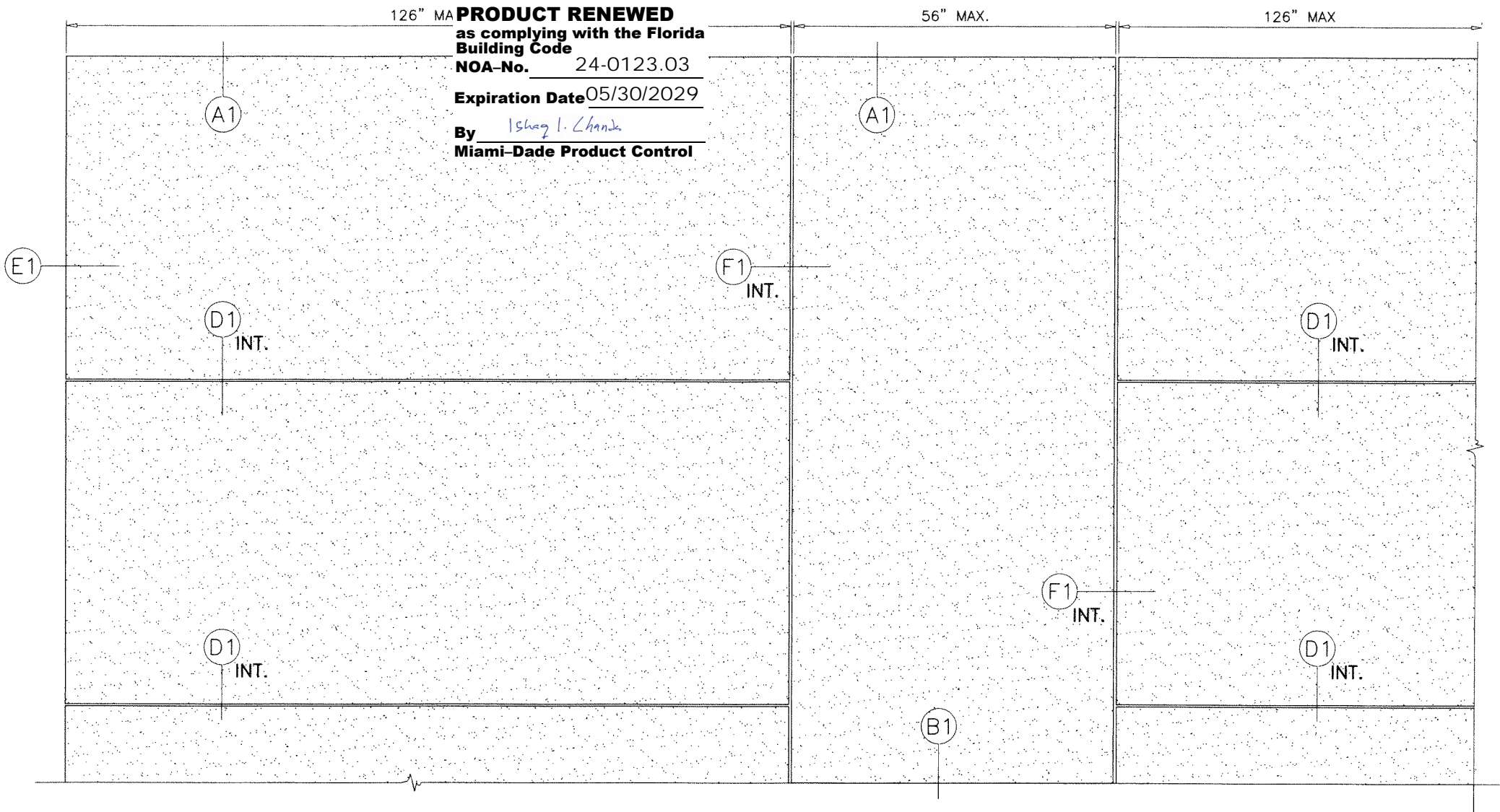

PANEL-1A TYPICAL ELEVATION

CHEMICAL ATTACHMENT AT MASONRY/CONCRETE STRUCTURES
 SEE SHEETS 9 AND 10 FOR INSTALLATION DETAILS

MASONRY/ CONC. STRUCTURE (BY OTHERS)



ARDEX X-77 MORTAR ATTACHED SYSTEM

ALTERNATE COMPOSITE PANEL-1A FACADE SHALL ONLY BE INSTALLED IN FRONT OF CBS CONSTRUCTION (ASTM-90) OR CONCRETE STRUCTURE, FULL COVERED ARDES X-77 MORTAR. USE SHEET 9 AND 10.
 APPLICABLE FIRE SEPARATION DISTANCE TO BE REVIEWED BY AHJ.

JAN 22 2024

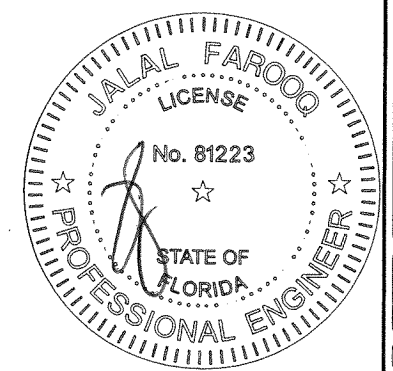

af c
AL-FAROOQ CORPORATION
 ENGINEERS & PRODUCT DEVELOPMENT
 9360 SUNSET DRIVE, SUITE 220
 MIAMI, FLORIDA 33173 (C.A.N. 3538)
 TEL. (305) 264-8100 FAX. (305) 262-6978
 DEKTON/COSENTINO

DEKTON ULTRA COMPACT PANEL FACADE SYSTEM (N.I.)
C&C NORTH AMERICA, INC. dba
COSENTINO NORTH AMERICA,
 355 ALHAMBRA CIRCLE, SUITE 1000
 CORAL GABLES, FL. 33134
 PHONE: (786) 686-5060

no.	date	description
A	05.14.19	REV. PER RER COMMENTS
B	10.05.21	2020 FCC UPDATE
C	01.19.24	NO CHANGE THIS SHEET

date: 09-19-18
 scale: 1/2"=1'-0"
 dr. by: MLS
 chk. by:

drawing no.
18-122
 sheet 2 of 11

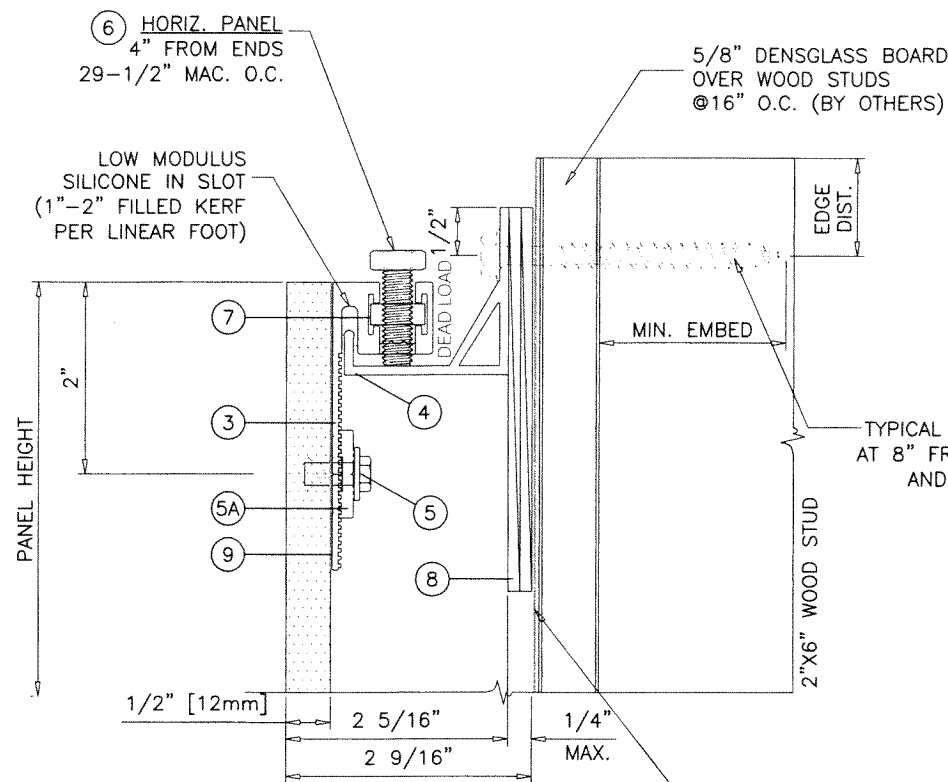

A STARTER ANCHOR

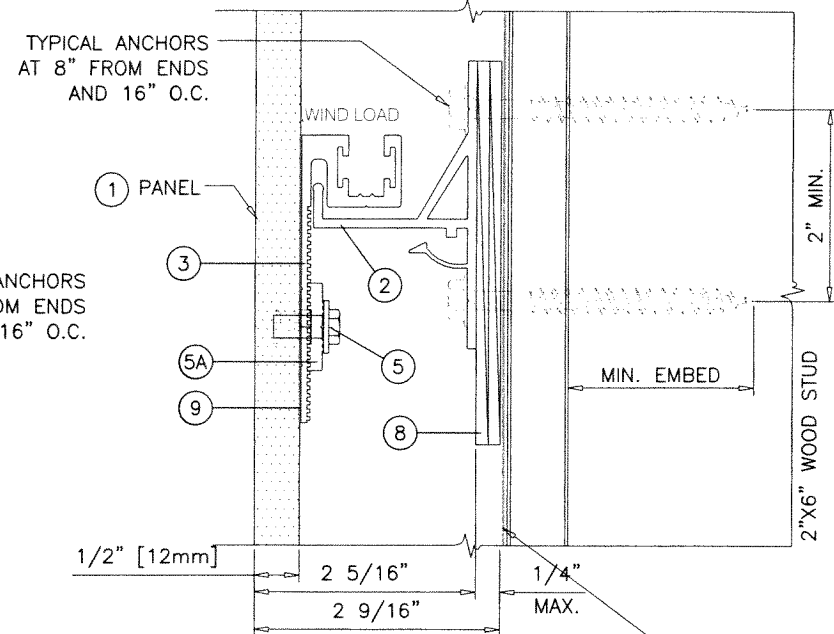

C INTERMEDIATE ANCHOR

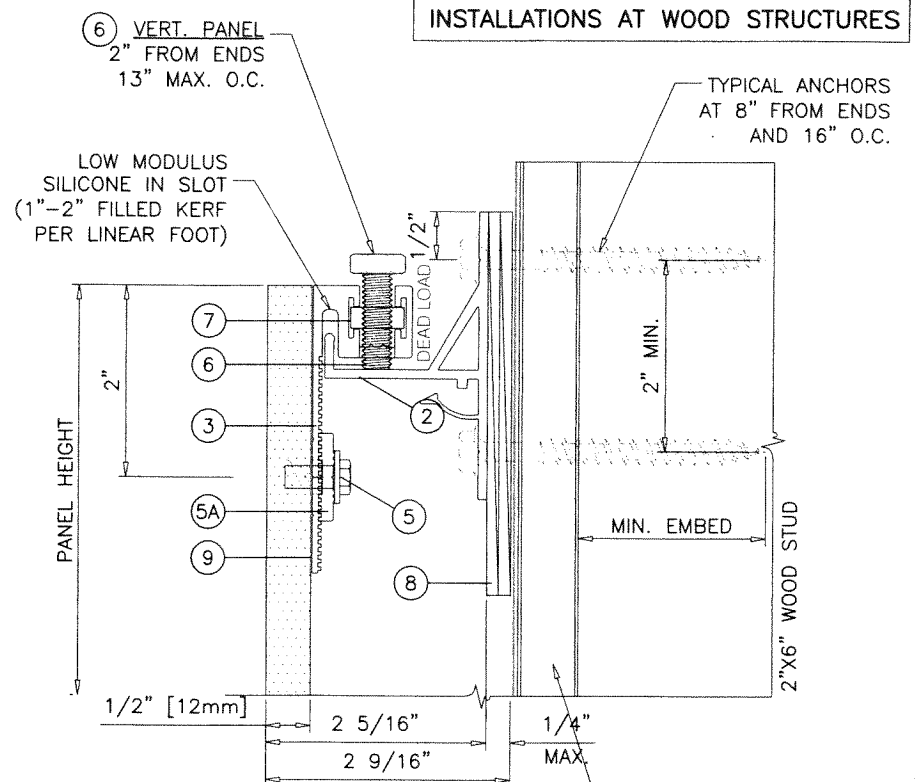

E ALT. STARTER ANCHOR

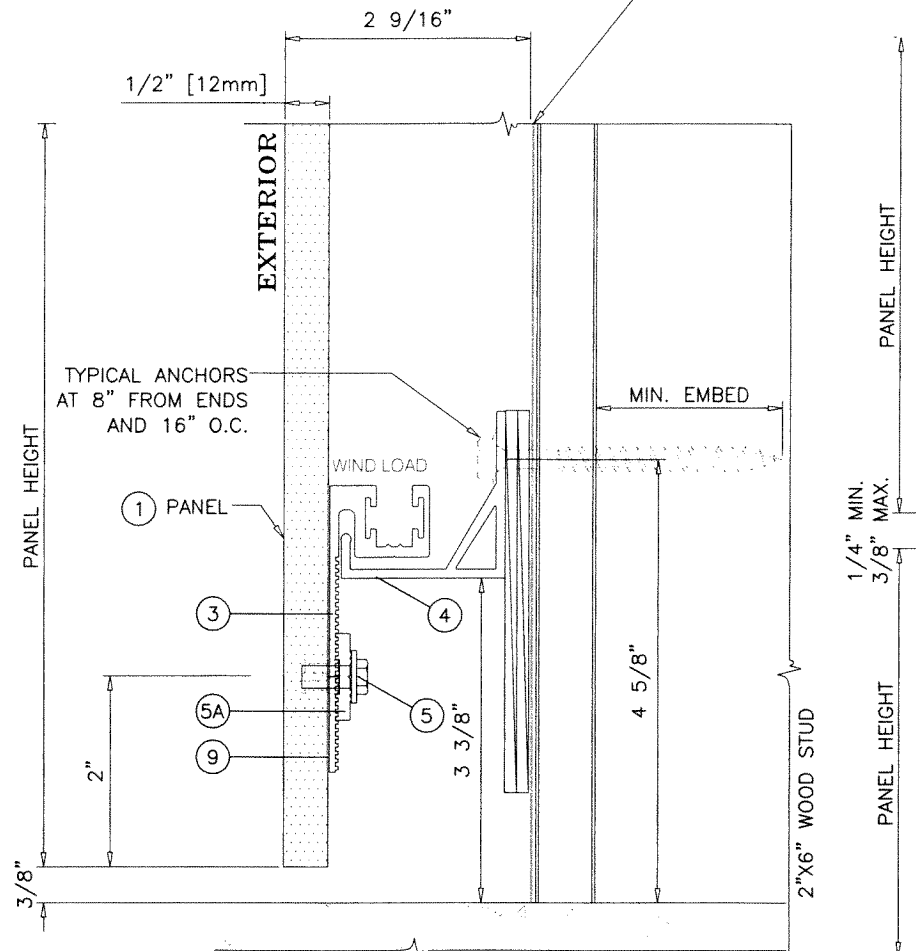

B STARTER ANCHOR

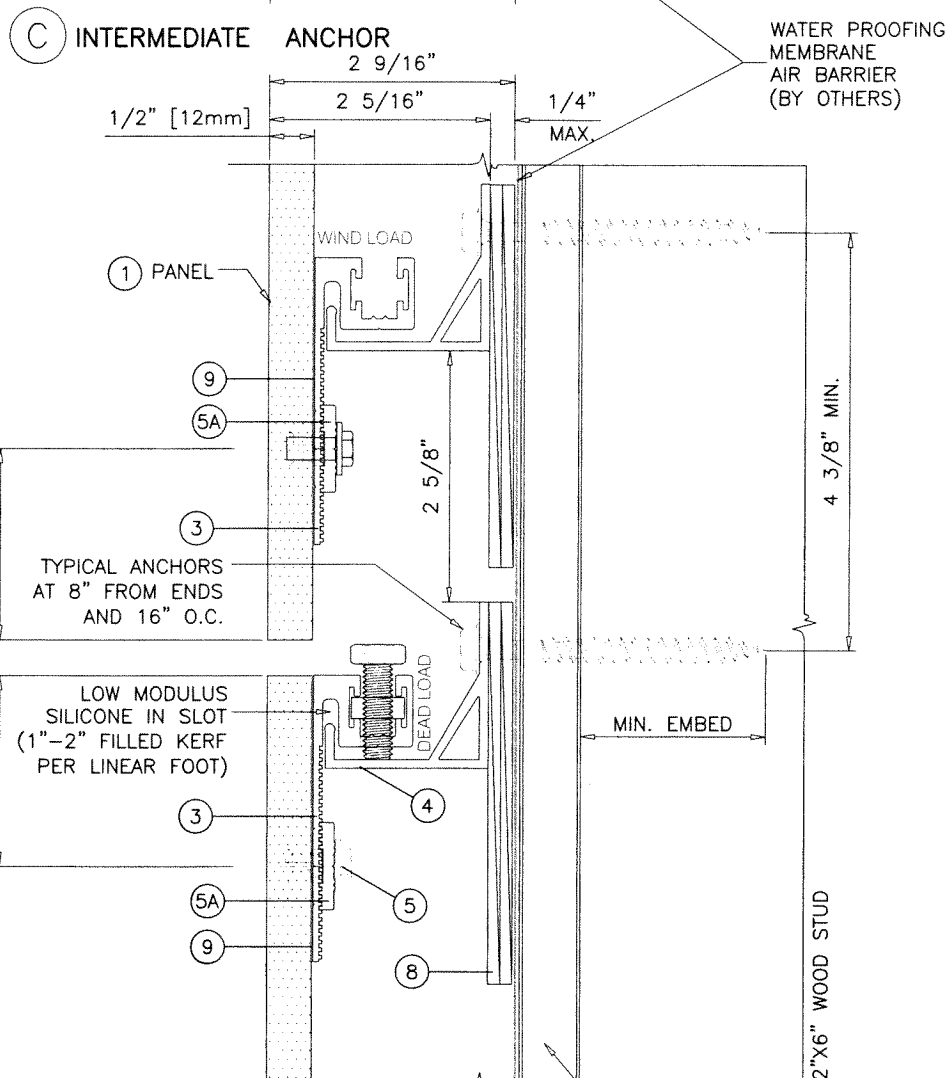

D INTERMEDIATE ANCHOR

TYPICAL ANCHORS:

1/4" x 3" HH POWERLAG BOLT BY 'SPAX'
(Fu=177 KSI, Fy=155 KSI)

DIRECTLY INTO 2 X 6 WOOD STUD
2" MIN. EMBED INTO WOOD

TYPICAL EDGE DISTANCE

INTO WOOD = 3/4" MIN.

PRODUCT RENEWED
as complying with the Florida
Building Code
NOA-No. 24-0123.03
Expiration Date 05/30/2029

By *Ishaq I. Chank*
Miami-Dade Product Control

JAN 22 2024

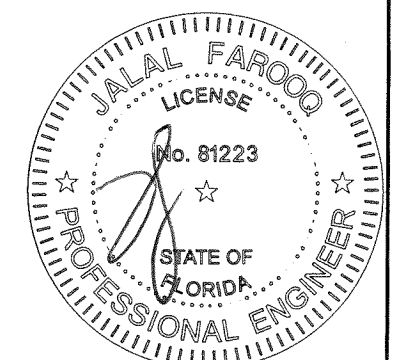

INSTALLATIONS AT WOOD STRUCTURES

a f c
AL-FAROOQ CORPORATION
ENGINEERS & PRODUCT DEVELOPMENT
9360 SUNSET DRIVE, SUITE 220
MIAMI, FLORIDA 33173
TEL. (305) 264-8100 FAX. (305) 262-6978
C.A.N. 3538
DEKTON/COSENTINO

DEKTON ULTRA COMPACT PANEL FACADE SYSTEM (N.I.)
C&C NORTH AMERICA, INC. dba
COSENTINO NORTH AMERICA
355 ALHAMBRA CIRCLE, SUITE 1000
CORAL GABLES, FL. 33134
PHONE: (786) 686-5060

no.	date	description
A	05.14.19	REV. PER RER COMMENTS
B	10.05.21	2020 FBC UPDATE
C	01.19.24	NO CHANGE THIS SHEET

date:	09-19-18
scale:	1/2" = 1"
dr. by:	MLS
chk. by:	

drawing no.
18-122
sheet 3 of 11

PRODUCT RENEWED
 as complying with the Florida
 Building Code
 NOA-No. 24-0123.03
 Expiration Date 05/30/2029
 By Ishaq I. Chande
 Miami-Dade Product Control

af c
AL-FAROOQ CORPORATION
 ENGINEERS & PRODUCT DEVELOPMENT
 9360 SUNSET DRIVE, SUITE 220
 MIAMI, FLORIDA 33173 (C.A.N. 3538)
 TEL. (305) 264-8100 FAX. (305) 262-6978
 DEKTON\COSENTINO

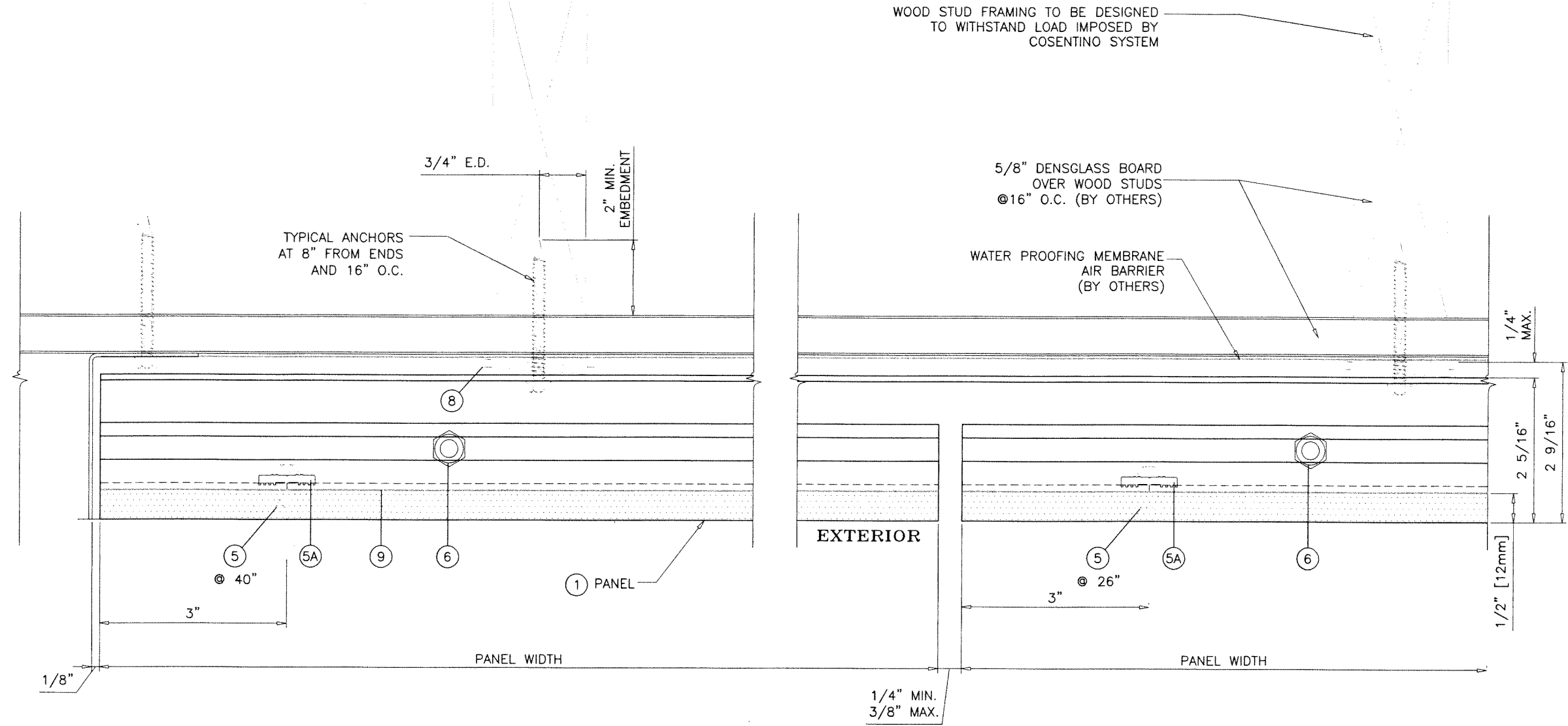

DEKTON ULTRA COMPACT PANEL FACADE SYSTEM (N.I.)
C&C NORTH AMERICA, INC. dba
COSENTINO NORTH AMERICA
 355 ALHAMBRA CIRCLE, SUITE 1000
 CORAL GABLES, FL. 33134
 PHONE: (786) 686-5060

revisions:

no	date	description
A	05.14.19	REV. PER RER COMMENTS
B	10.05.21	2020 FBC UPDATE
C	01.19.24	NO CHANGE THIS SHEET

date: 09-19-18
 scale: 1/2" = 1"
 dr. by: MLS
 chk. by:

drawing no.
18-122
 sheet 4 of 11

JAN 22 2024

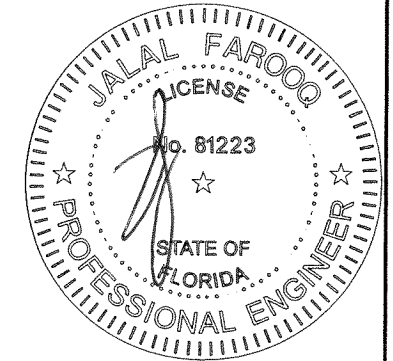

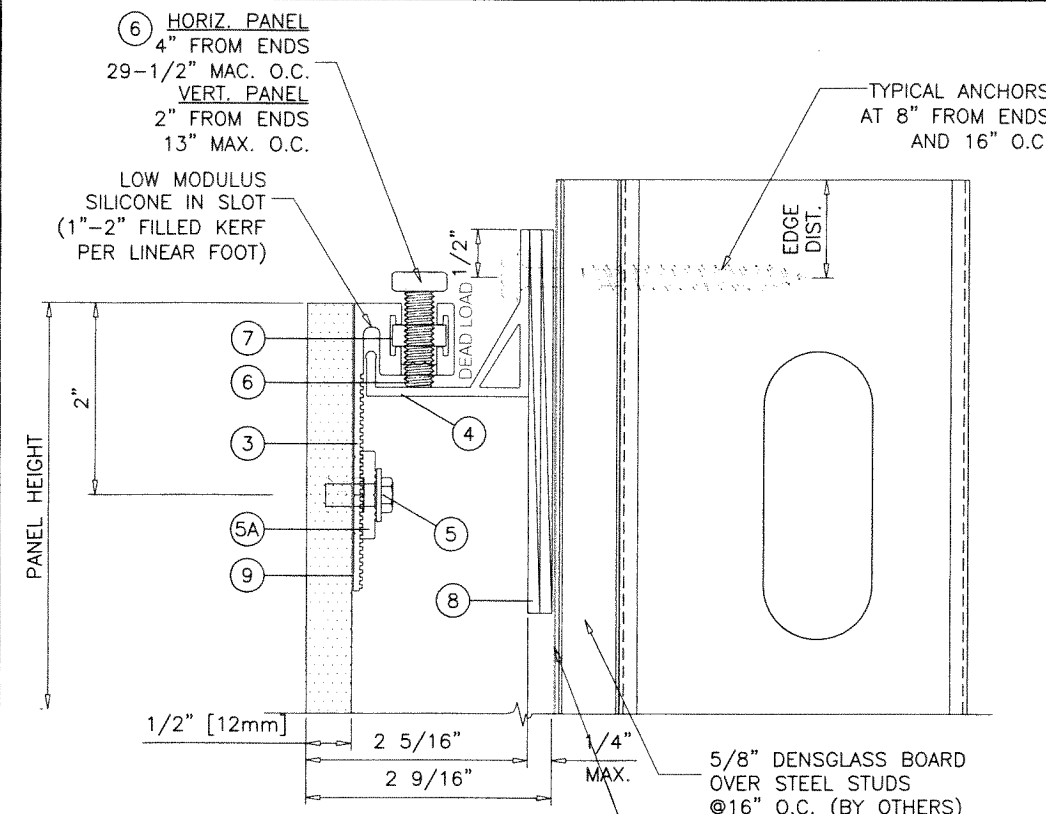

A STARTER ANCHOR

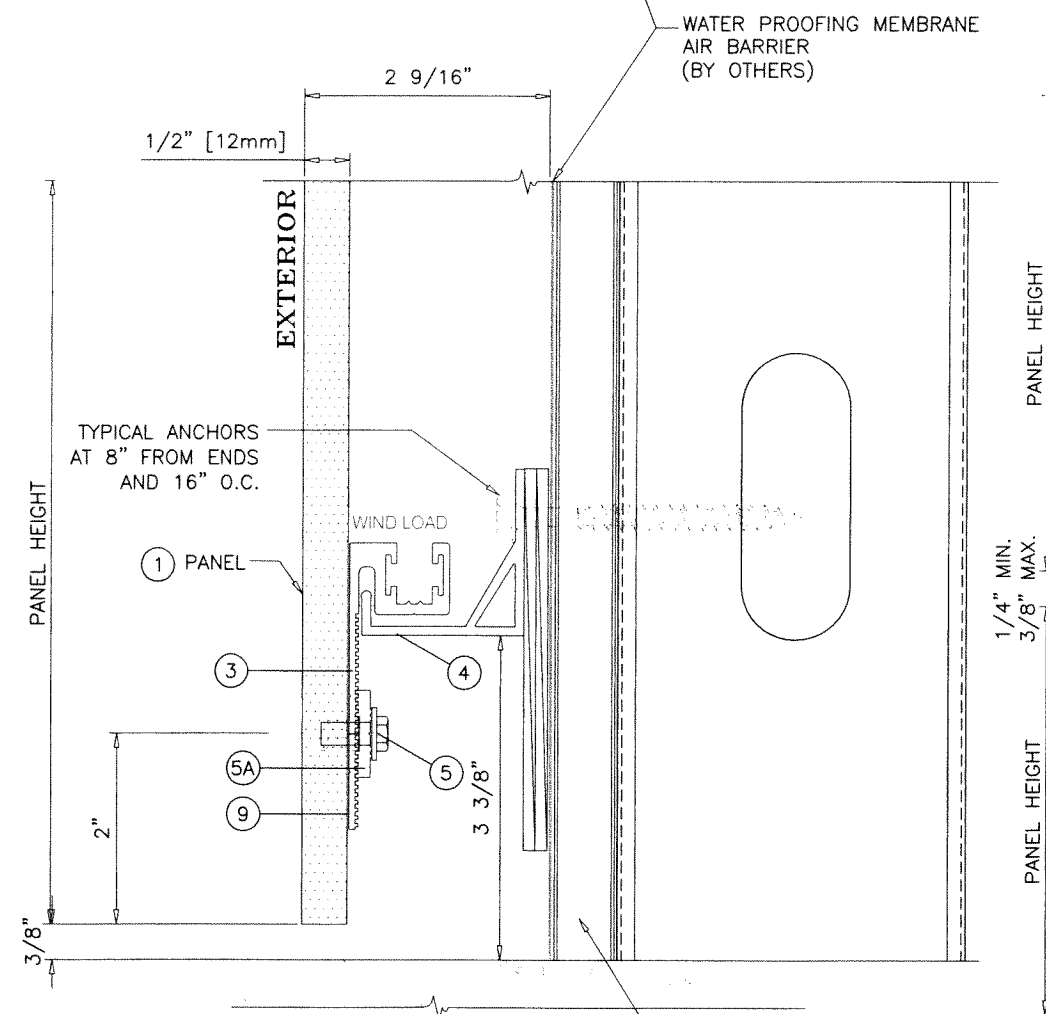

B STARTER ANCHOR

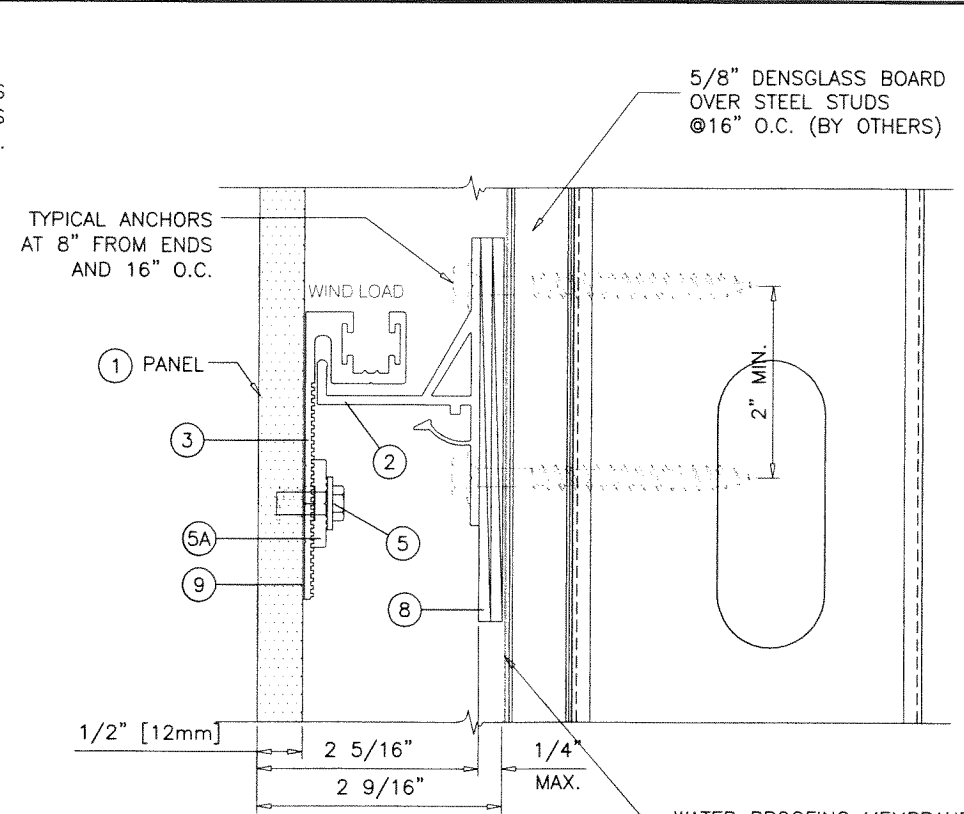

C INTERMEDIATE ANCHOR

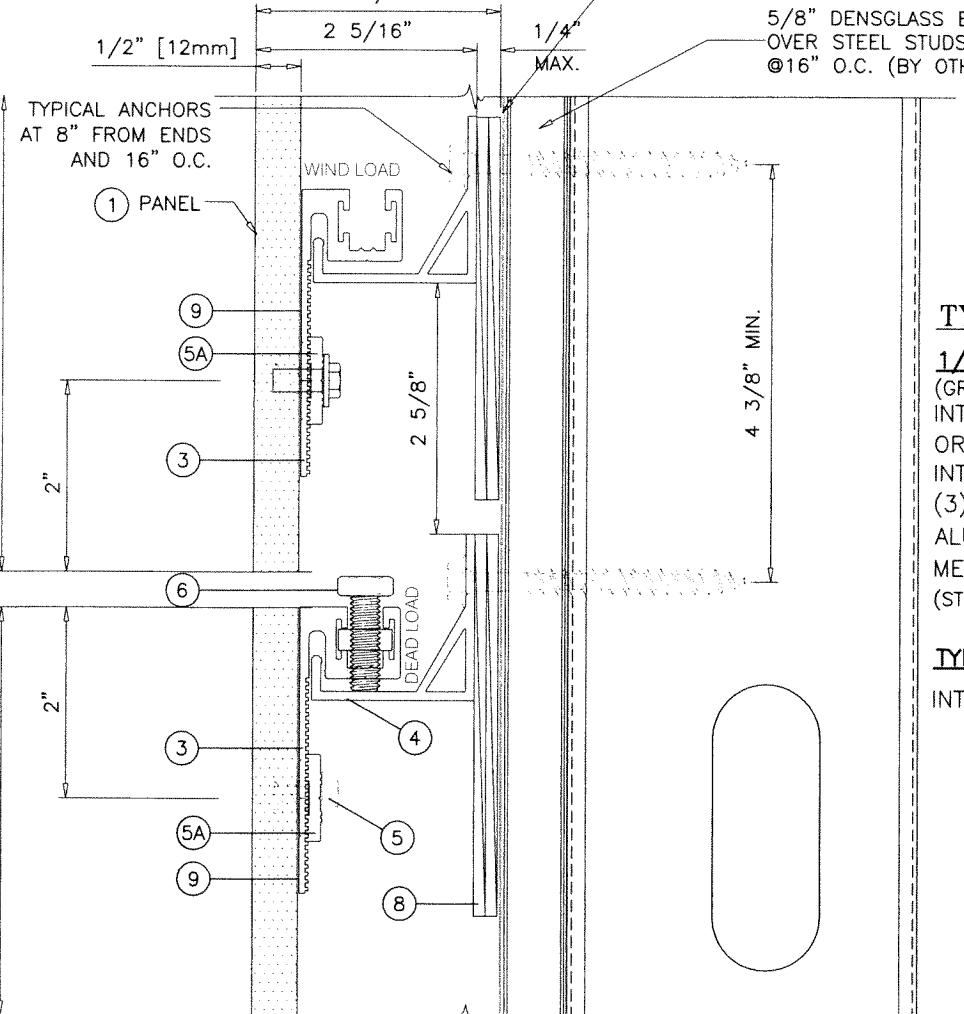

D INTERMEDIATE ANCHOR

PRODUCT RENEWED
 as complying with the Florida
 Building Code
 NOA-No. 24-0123.03
 Expiration Date 05/30/2029
 By Ishag I. Chank
 Miami-Dade Product Control

TYPICAL ANCHORS:
1/4" X 3" DRILL-FLEX SELF DRILLING FASTENERS BY 'DEWALT'
 (GRADE 5 CRS)
 INTO METAL STUDS (14 GA. MIN.) (Fy = 36 KSI MIN.)
 OR
 INTO METAL STRUCTURES
 (3) THREADS MIN. PENETRATION BEYOND SUBSTRATE
 ALUMINUM: 1/8" THK. MIN. (6063-T5 MIN.)
 METAL STRUCT.: 1/8" THK. MIN. (Fy = 36 KSI MIN.)
 (STEEL IN CONTACT WITH ALUMINUM TO BE PLATED OR PAINTED)

TYPICAL EDGE DISTANCE
 INTO METAL STRUCTURES = 3/4" MIN.

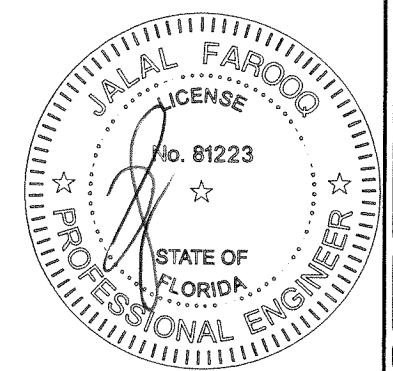

JAN 22 2024

DEKTON ULTRA COMPACT PANEL FACADE SYSTEM (N.I.)
C&C NORTH AMERICA, INC. dba
COSENTINO NORTH AMERICA
 355 ALHAMBRA CIRCLE, SUITE 1000
 CORAL GABLES, FL. 33134
 PHONE: (786) 686-5060

no	date	description	by
A	05.14.19	REV. PER RER COMMENTS	
B	10.05.21	2020 FBC UPDATE	
C	01.19.24	NO CHANGE THIS SHEET	

revisions:

date: 09-19-18
 scale: 1/2" = 1"
 dr. by: MLS
 ch. by:

drawing no. 18-122
 sheet 5 of 11



PRODUCT RENEWED
as complying with the Florida
Building Code

NOA-No. 24-0123.03

Expiration Date 05/30/2029

By Ishag I. Chande
Miami-Dade Product Control

2" X 6" 14 GA. STEEL STUD FRAMING
AT 16" O.C. (BY OTHERS)
MUST BE DESIGNED TO WITHSTAND LOADS
IMPOSED BY COSENTINO SYSTEM

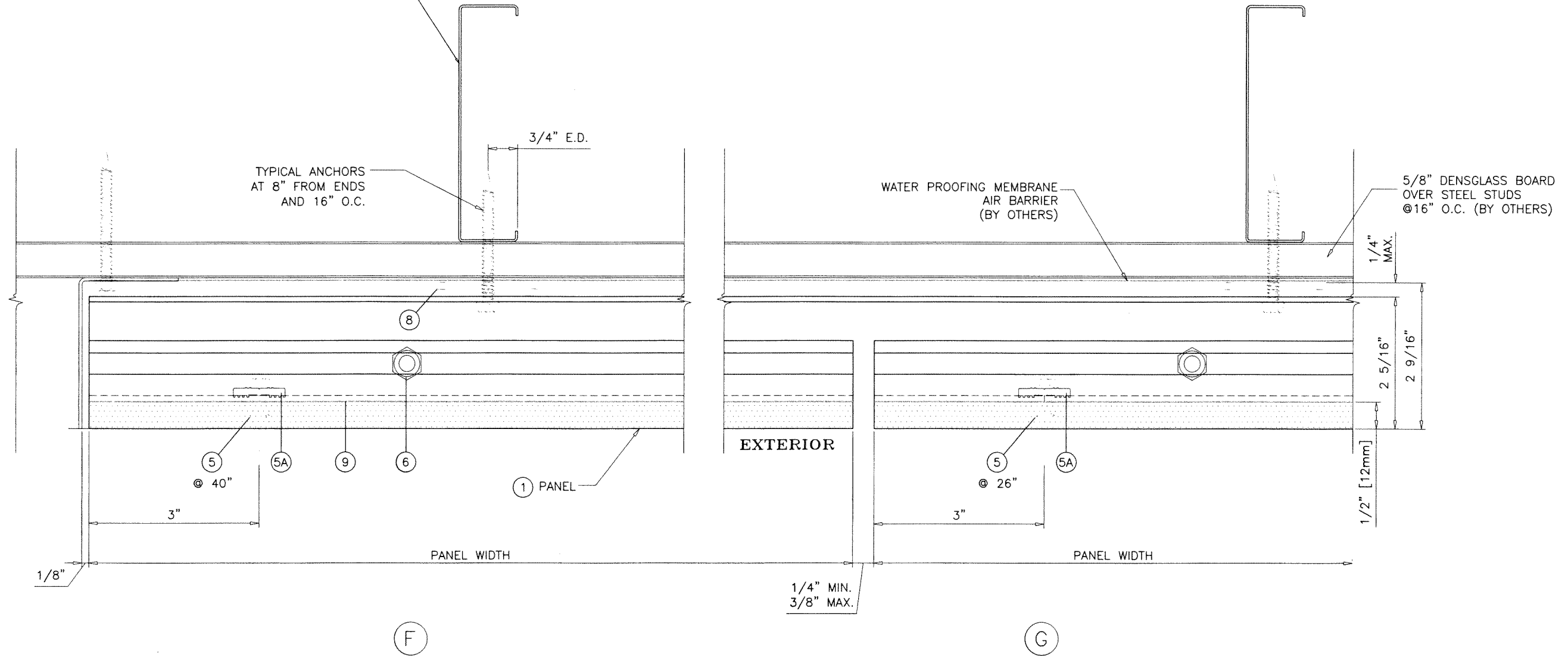

DEKTON ULTRA COMPACT PANEL FACADE SYSTEM (N.I.)

C&C NORTH AMERICA, INC. dba
COSENTINO NORTH AMERICA.
355 ALHAMBRA CIRCLE, SUITE 1000
CORAL GABLES, FL. 33134
PHONE: (786) 686-5060

no	date	description	by
A	05.14.19	REV. PER RER COMMENTS	
B	10.05.21	2020 FCC UPDATE	
C	01.19.24	NO CHANGE THIS SHEET	

date: 09-19-18
scale: 1/2" = 1"
dr. by: MLS
chk. by:

drawing no.
18-122

sheet 6 of 11

JAN 22 2024

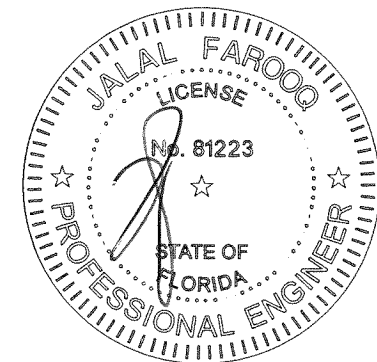

AL-FAROOQ CORPORATION
ENGINEERS & PRODUCT DEVELOPMENT
9360 SUNSET DRIVE, SUITE 220
MIAMI, FLORIDA 33173 (C.A.N. 3538)
TEL. (305) 264-8100 FAX. (305) 262-6978

DEKTON/COSENTINO

INSTALLATIONS AT MASONRY/CONC STRUCTURES

af c
AL-FAROOQ CORPORATION
 ENGINEERS & PRODUCT DEVELOPMENT
 9360 SUNSET DRIVE, SUITE 220
 MIAMI, FLORIDA 33173 (C.A.N. 3538)
 TEL. (305) 264-8100 FAX. (305) 262-6978
 DEKTON/COSENTINO

DEKTON ULTRA COMPACT PANEL FACADE SYSTEM (N.I.)
C&C NORTH AMERICA, INC. dba
COSENTINO NORTH AMERICA.
 355 ALHAMBRA CIRCLE, SUITE 1000
 CORAL GABLES, FL. 33134
 PHONE: (786) 686-5060

TYPICAL ANCHORS:
 1/4" DIA. AGGRE-GATOR BY 'DEWALT'
 (Fu=96 KSI, Fy=57 KSI)

DIRECTLY INTO CONCRETE OR BLOCK
 1-1/2" MIN. EMBED INTO CONCRETE
 1-1/4" MIN. EMBED INTO BLOCK

TYPICAL EDGE DISTANCE
 INTO CONCRETE = 3" MIN.
 INTO BLOCK = 4" MIN.

CONCRETE f'c = 3000 PSI MIN.
 C-90 HOLLOW/FILLED BLOCK f'm = 2000 PSI MIN.

PRODUCT RENEWED
 as complying with the Florida
 Building Code
NOA-No. 24-0123.03
Expiration Date 05/30/2029
 By *Ishag I. Chande*
Miami-Dade Product Control

JAN 2 2 2024

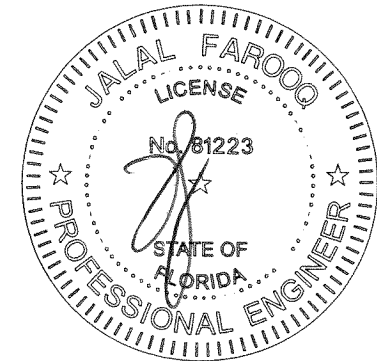

no.	date	description
A	05.14.19	REV. PER RER COMMENTS
B	10.05.21	2020 FBC UPDATE
C	01.19.24	NO CHANGE THIS SHEET

date: 09-19-18
 scale: 1/2" = 1"
 dr. by: MLS
 chk. by:

drawing no. 18-122
 sheet 7 of 11

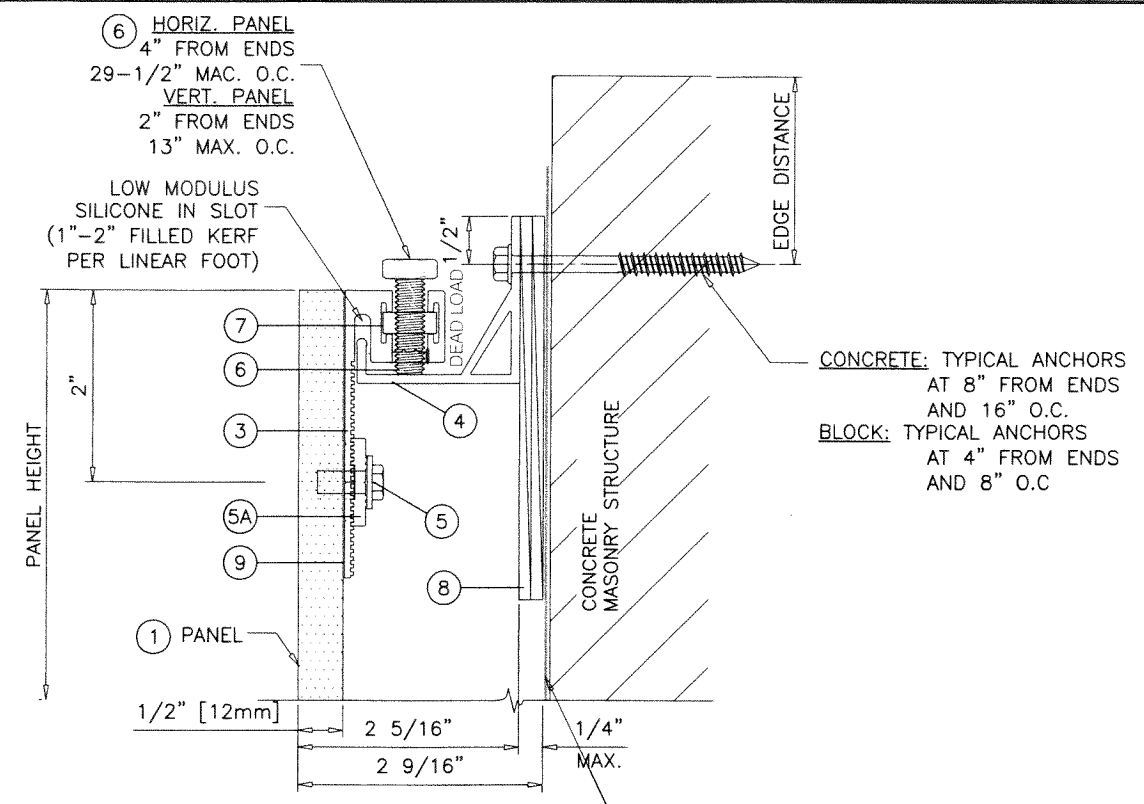

A STARTER ANCHOR

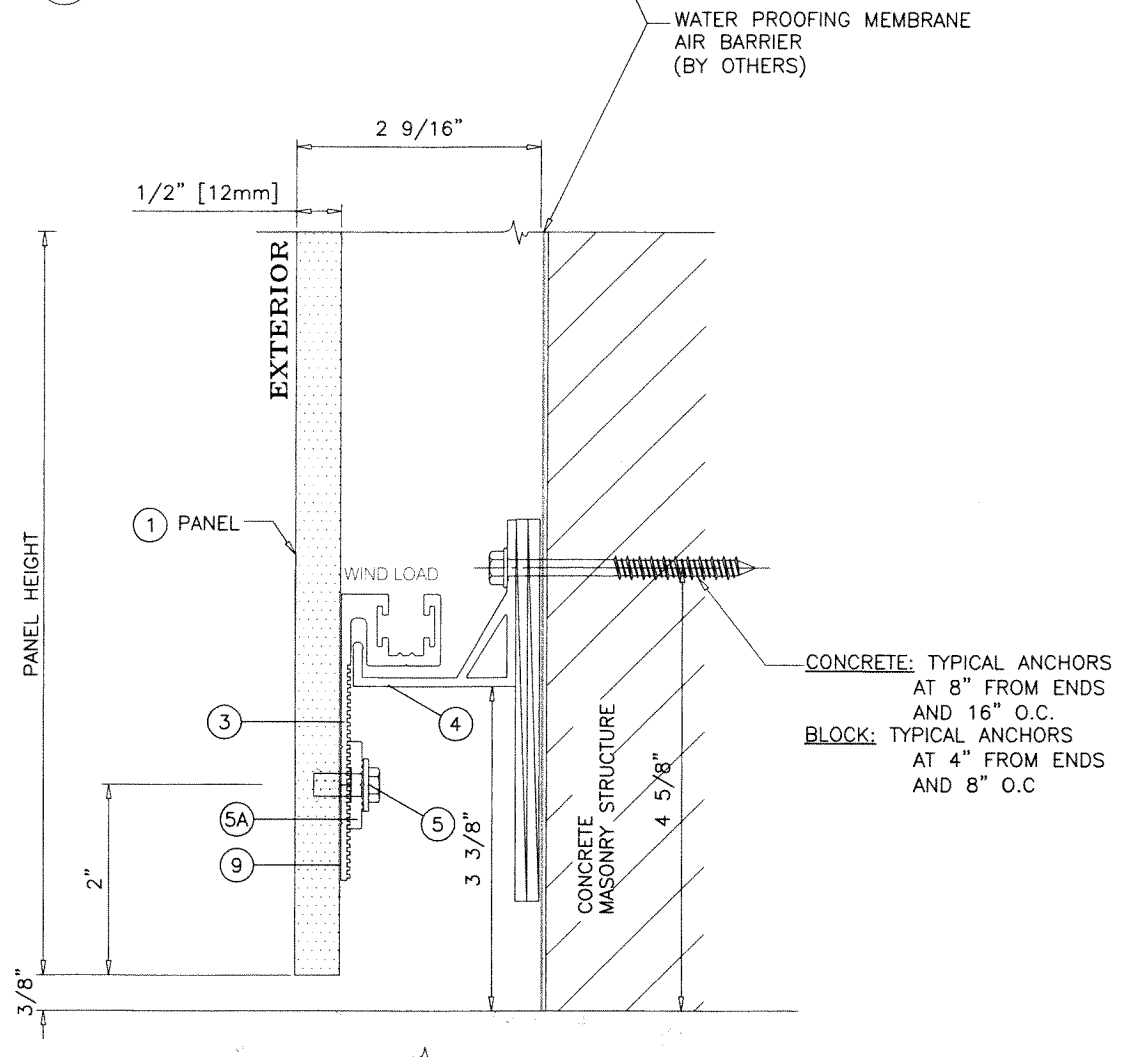

B STARTER ANCHOR

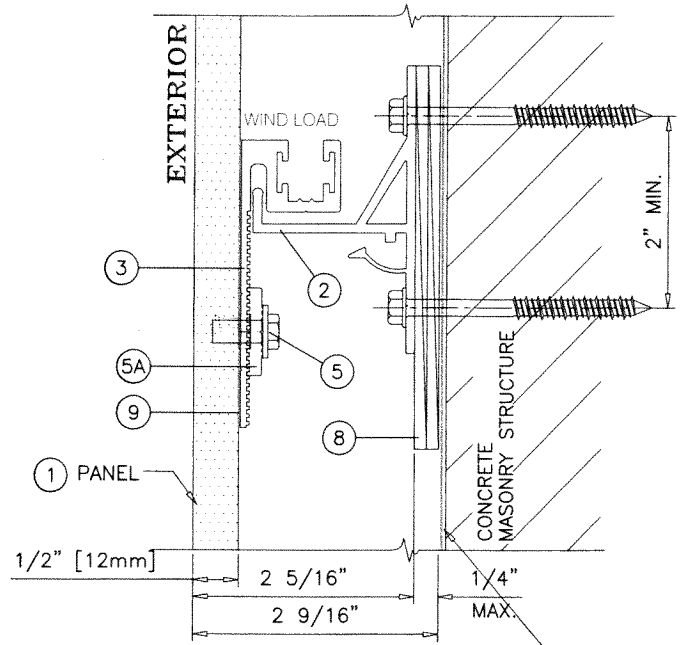

C INTERMEDIATE ANCHOR

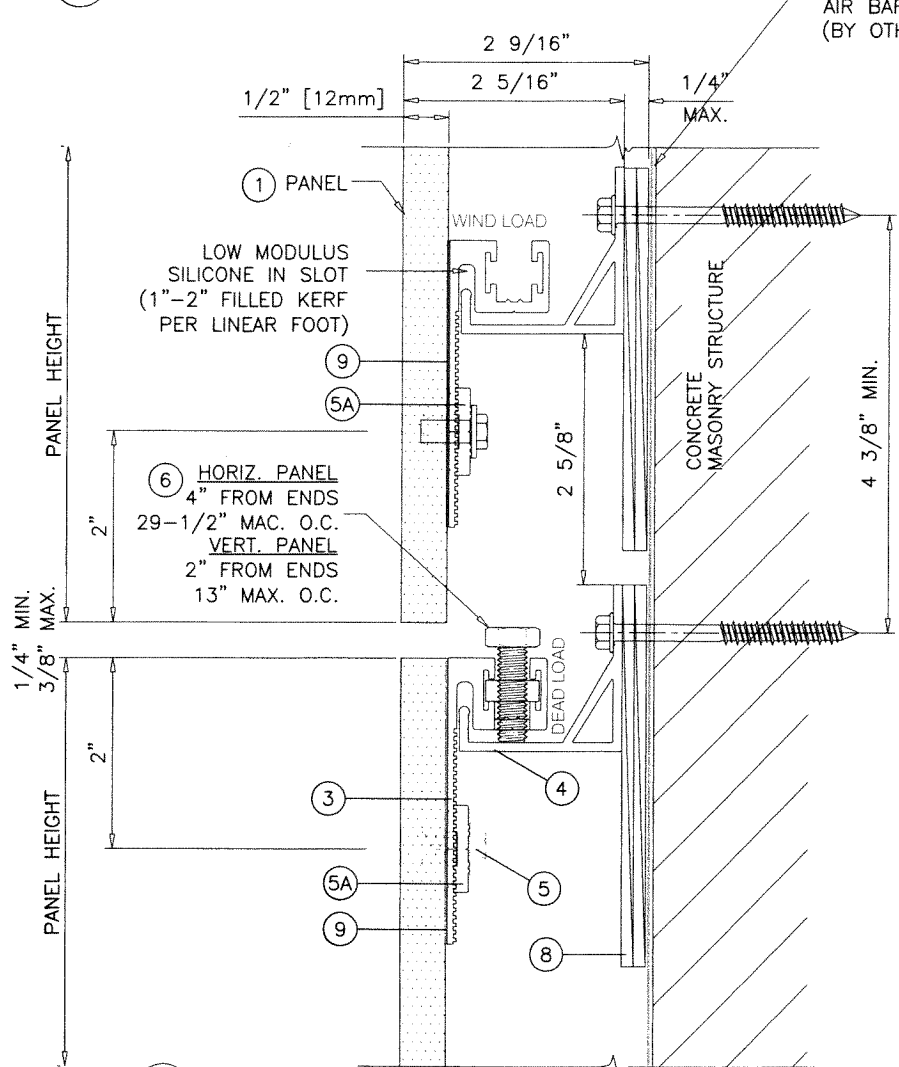

D INTERMEDIATE ANCHOR

CONCRETE: TYPICAL ANCHORS
 AT 8" FROM ENDS
 AND 16" O.C.
 BLOCK: TYPICAL ANCHORS
 AT 4" FROM ENDS
 AND 8" O.C.

CONCRETE: TYPICAL ANCHORS
 AT 8" FROM ENDS
 AND 16" O.C.
 BLOCK: TYPICAL ANCHORS
 AT 4" FROM ENDS
 AND 8" O.C.

WATER PROOFING MEMBRANE
 AIR BARRIER
 (BY OTHERS)

PRODUCT RENEWED
 as complying with the Florida
 Building Code
 NOA-No. 24-0123.03
 Expiration Date 05/30/2029
 By Ishaq I. Chande
 Miami-Dade Product Control

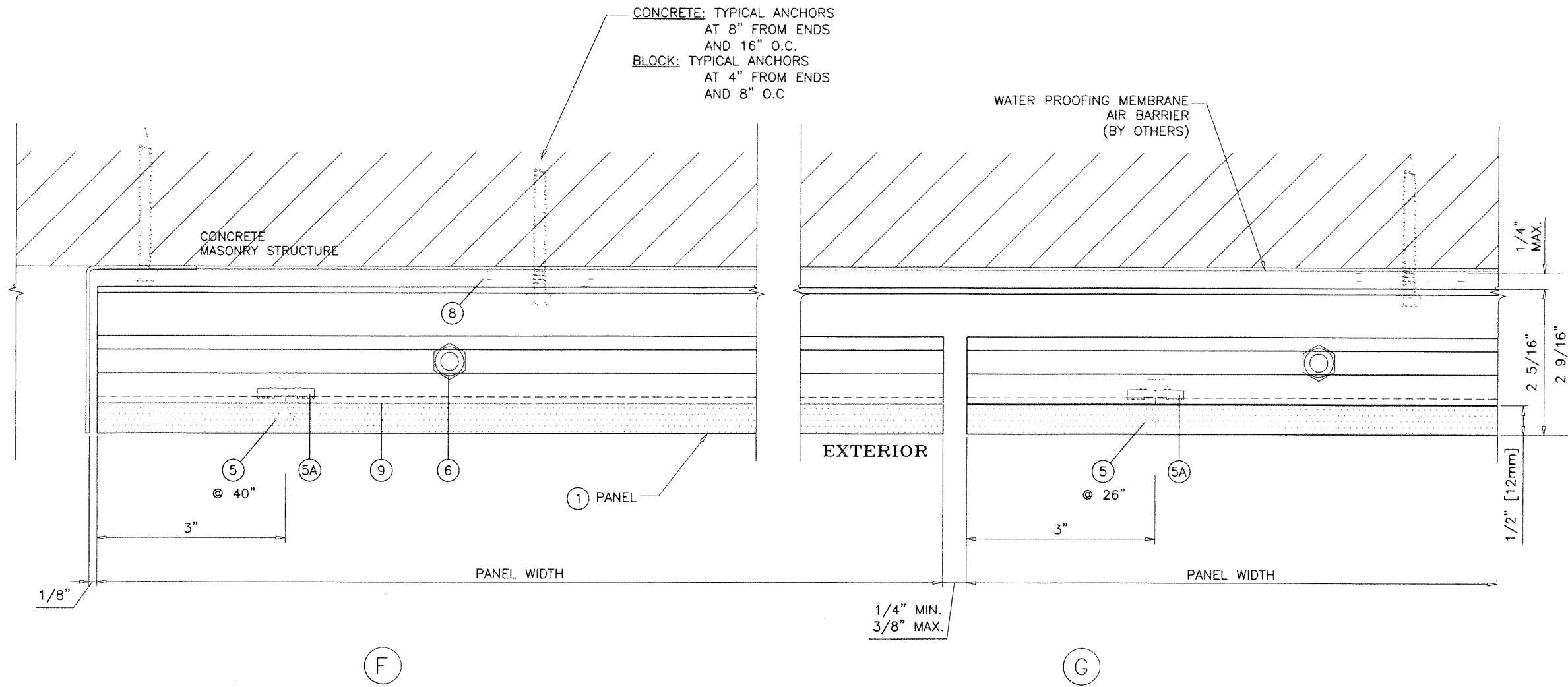

af c
AL-FAROOQ CORPORATION
 ENGINEERS & PRODUCT DEVELOPMENT
 9360 SUNSET DRIVE, SUITE 220
 MIAMI, FLORIDA 33173 (C.A.N. 3538)
 TEL. (305) 264-8100 FAX. (305) 262-6978
 DEKTON\COSENTINO

DEKTON ULTRA COMPACT PANEL FACADE SYSTEM (N.I.)
C&C NORTH AMERICA, INC. dba
COSENTINO NORTH AMERICA.
 355 ALHAMBRA CIRCLE, SUITE 1000
 CORAL GABLES, FL. 33134
 PHONE: (786) 686-5060

no	date	description
A	05.14.19	REV. PER PER COMMENTS
B	10.05.21	2020 FBC UPDATE
C	01.19.24	NO CHANGE THIS SHEET

revisions:
 date: 09-19-18
 scale: 1/2" = 1"
 dr. by: M.L.S.
 chk. by:

JAN 22 2024

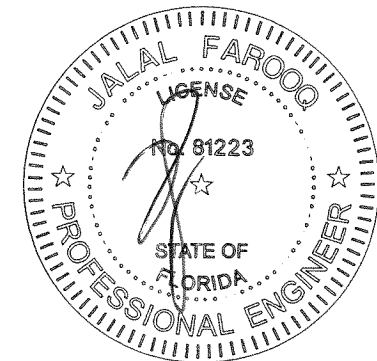

drawing no.
18-122
 sheet **8** of 11

INSTALLATIONS AT MASONRY/CONC STRUCTURES ONLY

A1

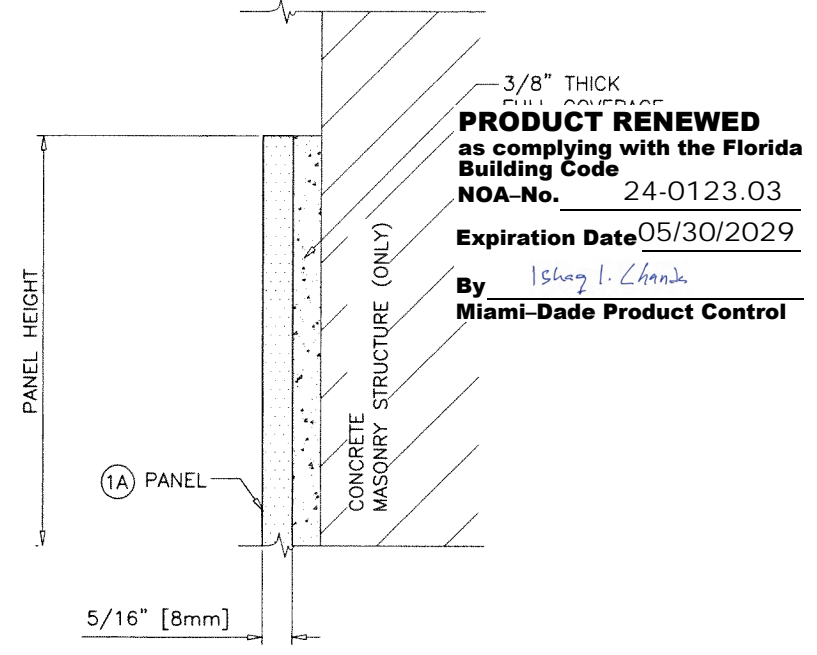

B1

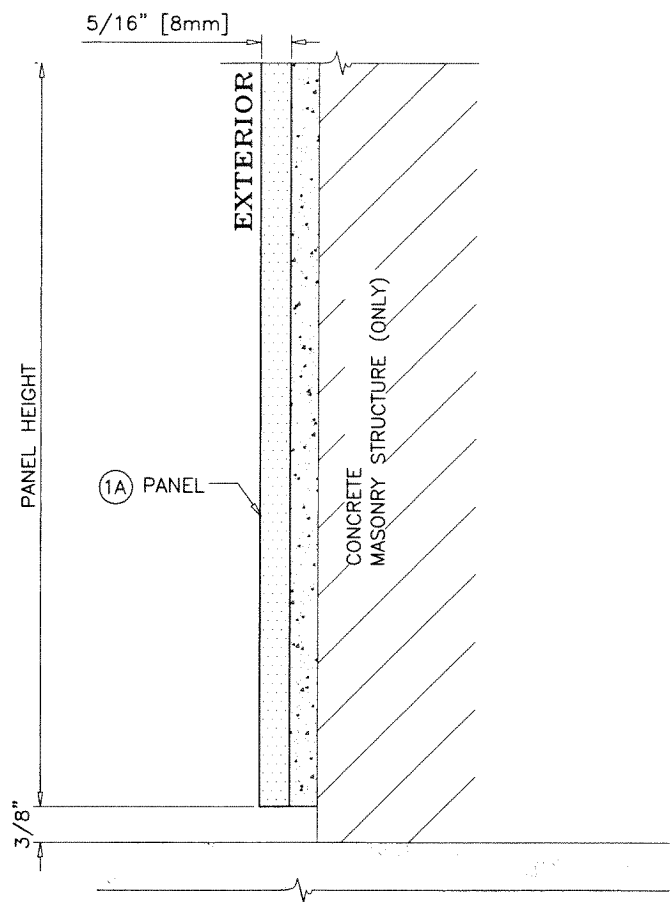

D1

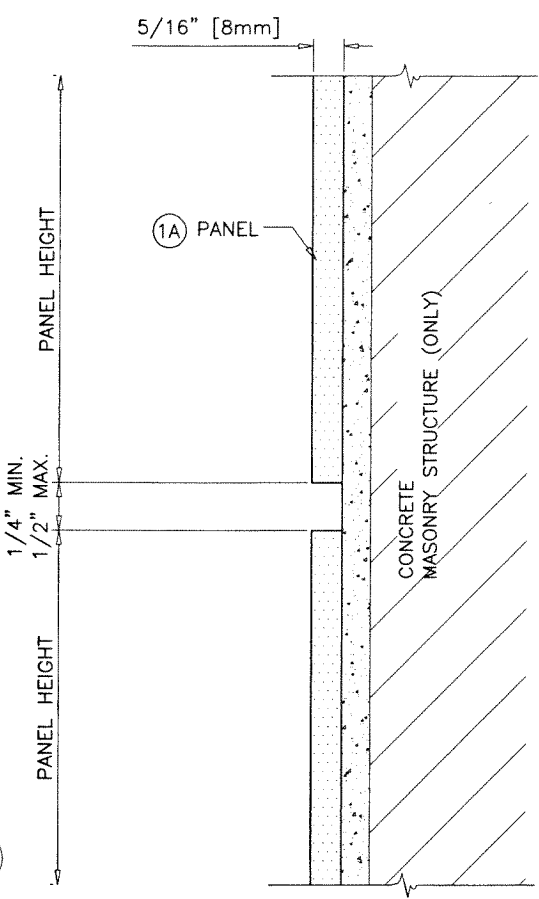

ARDEX X-77 MORTAR ATTACHED SYSTEM
 SEE SHEET 2 FOR ELEVATION

JAN 2 2 2024

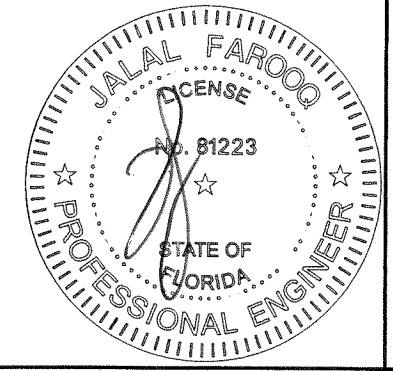

af c

AL-FAROOQ CORPORATION
 ENGINEERS & PRODUCT DEVELOPMENT
 9360 SUNSET DRIVE, SUITE 220
 MIAMI, FLORIDA 33173 (C.A.N. 3538)
 TEL. (305) 264-8100 FAX. (305) 262-6978
 DEKTON\COSENTINO

DEKTON ULTRA COMPACT PANEL FACADE SYSTEM (N.I.)

C&C NORTH AMERICA, INC. dba
COSENTINO NORTH AMERICA
 355 ALHAMBRA CIRCLE, SUITE 1000
 CORAL GABLES, FL. 33134
 PHONE: (786) 686-5060

no	date	by	description
A	05.14.19		REV. PER PER COMMENTS
B	10.05.21		2020 FBC UPDATE
C	01.19.24		NO CHANGE THIS SHEET

date: 09-19-18
 scale: 1/2" = 1"
 dr. by: M.L.S.
 chk. by:

drawing no.
18-122

sheet 9 of 11

INSTALLATIONS AT MASONRY/CONC STRUCTURES ONLY

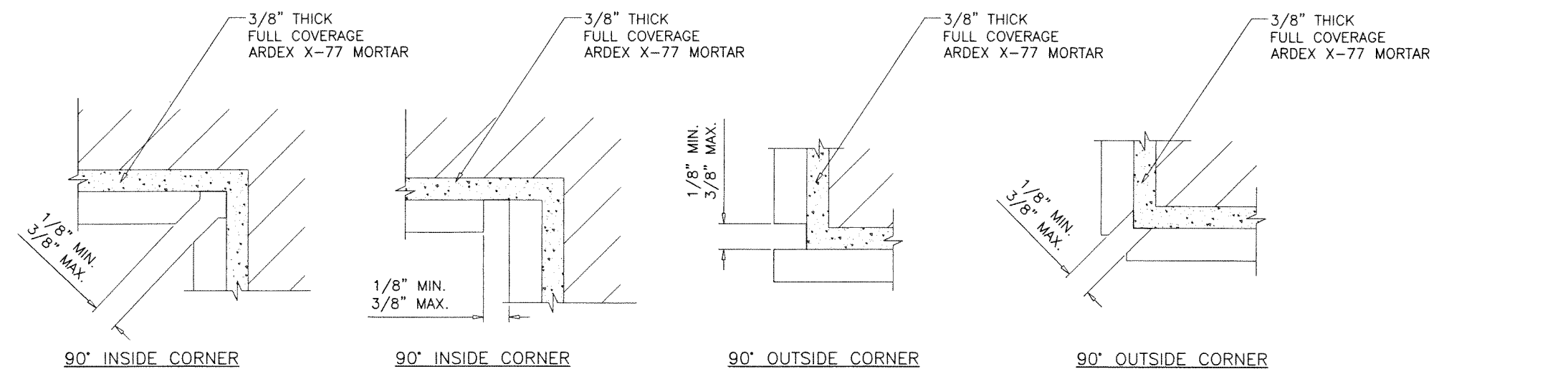

ILLUSTRATIVE SAMPLES SHOWN ABOVE, ANGLES MAY VARY

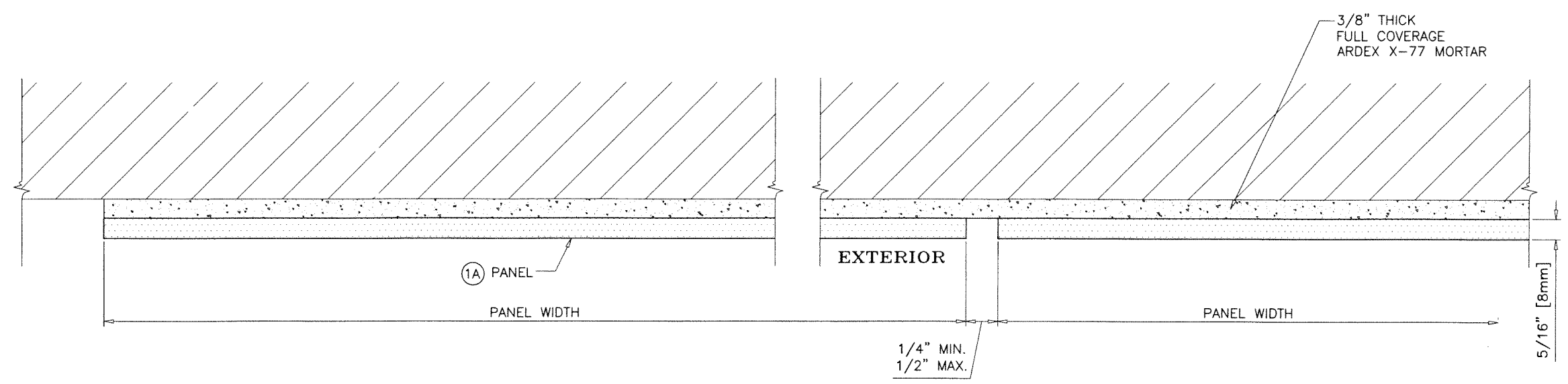

E1

PRODUCT RENEWED
 as complying with the Florida
 Building Code
 NOA-No. 24-0123.03
 Expiration Date 05/30/2029
 By *Ishag I. Chande*
 Miami-Dade Product Control

F1

ARDEX X-77 MORTAR ATTACHED SYSTEM
 SEE SHEET 2 FOR ELEVATION

JAN 22 2024

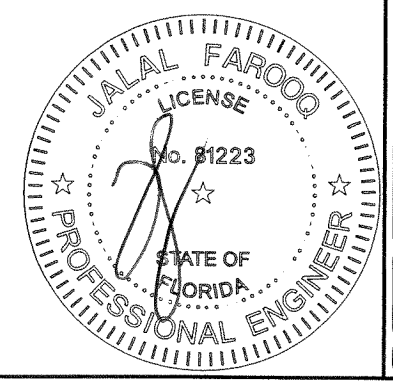

af c
AL-FAROOQ CORPORATION
 ENGINEERS & PRODUCT DEVELOPMENT
 9360 SUNSET DRIVE, SUITE 220
 MIAMI, FLORIDA 33173 (C.A.N. 3538)
 TEL. (305) 264-8100 FAX. (305) 262-6978
 DEKTON/COSENTINO

DEKTON ULTRA COMPACT PANEL FACADE SYSTEM (N.I.)
C&C NORTH AMERICA, INC. dba
COSENTINO NORTH AMERICA
 355 ALHAMBRA CIRCLE, SUITE 1000
 CORAL GABLES, FL. 33134
 PHONE: (786) 686-5060

no	date	description
A	05.14.19	REV. PER RER COMMENTS
B	10.05.21	2020 FBC UPDATE
C	01.19.24	NO CHANGE THIS SHEET

date: 09-19-18
 scale: 1/2" = 1"
 dr. by: M.L.S.
 chk. by:

drawing no.
18-122
 sheet 10 of 11

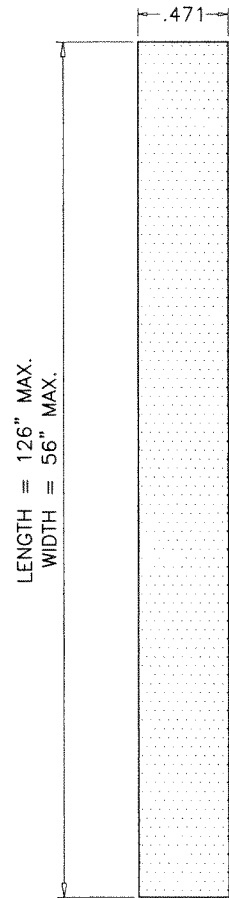

COSENTINO®

DEKTON ULTRACOMPACT PANEL
COMPOSED OF SILICOALUMINATES,
AMORPHOUS SILICA,
CRYSTALLINE SILICA (<11%)
ZIRCON AND INORGANIC PIGMENTS

1 COMPOSITE PANEL (1.2 CM)
SCALE 1:1

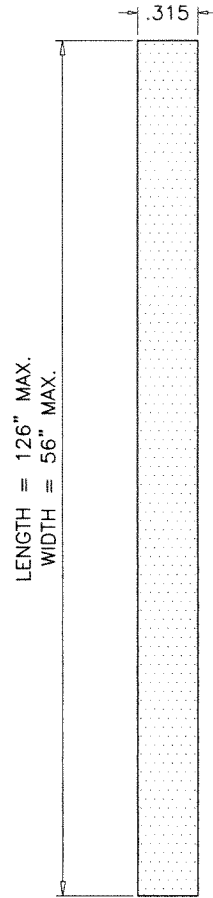

COSENTINO®

DEKTON ULTRACOMPACT PANEL
COMPOSED OF SILICOALUMINATES,
AMORPHOUS SILICA,
CRYSTALLINE SILICA (<11%)
ZIRCON AND INORGANIC PIGMENTS

1A COMPOSITE PANEL (8 MM)
SCALE 1:1

ITEM NO.	PART NO.	QUANTITY	DESCRIPTION	MATERIAL	MANF./SUPPLIER/REMARKS
1	-	AS REQD.	1.2 cm DEKTON ULTRACOMPACT PANEL	COMPOSITE	WEIGHT = APPROXIMATELY 6.6 Lbs/Sq. Ft.
1A	-	AS REQD.	8 mm DEKTON ULTRACOMPACT PANEL	COMPOSITE	WEIGHT = APPROXIMATELY 4.4 Lbs/Sq. Ft.
2	002	AS REQD.	GRIDWORX INTERMEDIATE ANCHOR	6005-T5	CLEAR ANODIZED
3	F301	AS REQD.	GRIDWORX ULTRA ANCHOR (CONTINUOUS)	6005-T5	CLEAR ANODIZED
4	001	AS REQD.	GRIDWORX STARTER J ANCHOR (CONTINUOUS)	6005-T5	CLEAR ANODIZED
5	555 020 830	AS REQD.	UNDERCUT ANCHOR	ST. STEEL	
5A	-	AS REQD.	GRIDWORX ULTRA LOCKING PLATE	6005-T5	CLEAR ANODIZED
6	-	AS REQD.	GRIDWORX 5/16" 18-8 PITCH ADJUSTMENT BOLT	ST. STEEL	BLACK FINISH
7	-	AS REQD.	GRIDWORX 5/16"-18 THREAD PITCH ADJUSTMENT NUT	ST. STEEL	-
8	C100, C101, C102	AS REQD.	FULL BEARING PLASTIC SHIM	HI-IMPACT PLASTIC	-
9	-	AS REQD.	HIGH STRENGTH, FAST CURE STP ADHESIVE/SEALANT	STP	80%-100% COVERAGE ON ULTRA ANCHOR

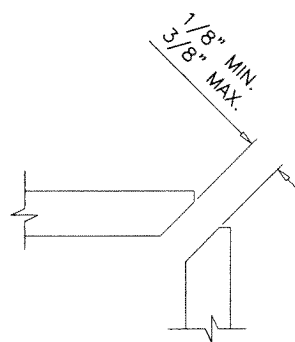

90° INSIDE CORNER

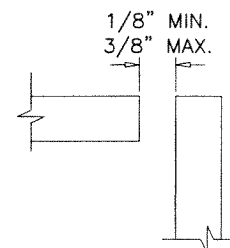

90° INSIDE CORNER

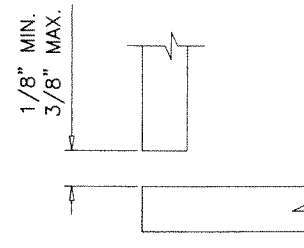

90° OUTSIDE CORNER

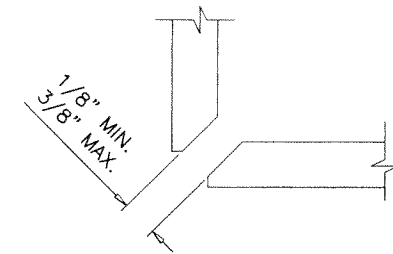

90° OUTSIDE CORNER

ILLUSTRATIVE SAMPLES SHOWN ABOVE, ANGLES MAY VARY

ALL ANCHOR CONDITIONS EXCEPT MORTAR ATTACHED SYSTEM

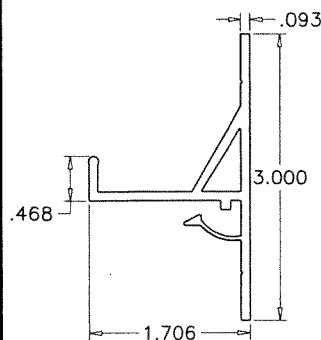

2 INTERMEDIATE ANCHOR

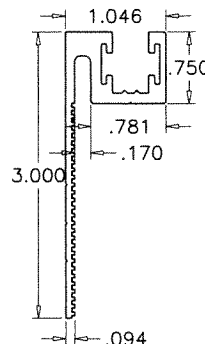

3 ULTRA ANCHOR

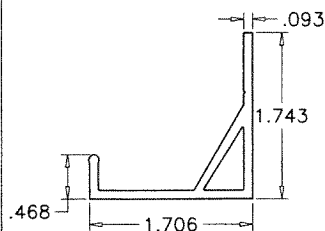

4 STARTER J ANCHOR

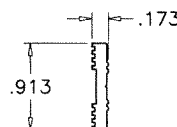

5A ULTRA LOCKING PLATE

PRODUCT RENEWED
as complying with the Florida
Building Code
NOA-No. 24-0123.03
Expiration Date 05/30/2029
By Ishtaq I. Chank
Miami-Dade Product Control

JAN 2 2 2024

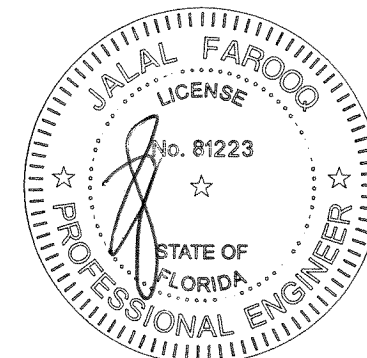

afc

AL-FAROOQ CORPORATION
ENGINEERS & PRODUCT DEVELOPMENT
9360 SUNSET DRIVE, SUITE 220
MIAMI, FLORIDA 33173 (C.A.N. 3538)
TEL. (305) 264-8100 FAX. (305) 262-6978

DEKTON ULTRA COMPACT PANEL FAÇADE SYSTEM (N.I.)

C&C NORTH AMERICA, INC. dba
COSENTINO NORTH AMERICA.
355 ALHAMBRA CIRCLE, SUITE 1000
CORAL GABLES, FL. 33134
PHONE: (786) 686-5060

no.	date	description
A	05.14.19	REV. PER RER COMMENTS
B	10.05.21	2020 FBC UPDATE
C	01.19.24	NO CHANGE THIS SHEET

revisions:
date: 09-19-18
scale: 1/2" = 1"
dr. by: M.L.S.
chk. by:

drawing no.
18-122
sheet 11 of 11