



DEPARTMENT OF REGULATORY AND ECONOMIC RESOURCES (RER)  
BOARD AND CODE ADMINISTRATION DIVISION

**NOTICE OF ACCEPTANCE (NOA)**

MIAMI-DADE COUNTY  
PRODUCT CONTROL SECTION  
11805 SW 26 Street, Room 208  
Miami, Florida 33175-2474  
T (786) 315-2590 F (786) 315-2599  
[www.miamidade.gov/economy](http://www.miamidade.gov/economy)

**Nu-Vue Industries, Inc.**  
**1055 East 29 Street**  
**Hialeah, Florida 33013**

**SCOPE:** This NOA is being issued under the applicable rules and regulations governing the use of construction materials. The documentation submitted has been reviewed and accepted by Miami-Dade County RER-Product Control Section to be used in Miami Dade County and other areas where allowed by the Authority Having Jurisdiction (AHJ).

This NOA shall not be valid after the expiration date stated below. The Miami-Dade County Product Control Section (In Miami Dade County) and/or the AHJ (in areas other than Miami Dade County) reserve the right to have this product or material tested for quality assurance purposes. If this product or material fails to perform in the accepted manner, the manufacturer will incur the expense of such testing and the AHJ may immediately revoke, modify, or suspend the use of such product or material within their jurisdiction. RER reserves the right to revoke this acceptance if it is determined by Miami-Dade County Product Control Section that this product or material fails to meet the requirements of the applicable building code.

This product is approved as described herein and has been designed to comply with the Florida Building Code, including the High Velocity Hurricane Zone.

**DESCRIPTION: Series NVTA, NVTAS, NVBH, NVUH, NVRT and NVTH Steel Wood Connectors**

**APPROVAL DOCUMENT:** Drawing No. **JA-2029-23**, titled “SERIES NVTA, NVTAS, NVBH, NVUH, NVRT AND NVTH STEEL WOOD CONNECTORS”, sheets 1 through 5 of 5, dated 01/11/2024, prepared by Javad Ahmad PE, Inc., signed and sealed by Javad Ahmad, P.E. on 02/06/2024, bearing the Miami-Dade County Product Control revision stamp with the Notice of Acceptance (NOA) number and expiration date by the Miami-Dade County Product Control Section.

**MISSILE IMPACT RATING: None**

**LABELING:** A permanent mark with the manufacturer’s name, acronym or logo is to be located on each unit. A permanent label with the manufacturer’s name or logo, city, state, model/series, and the statement reading ‘Miami-Dade County Product Control Approved’ is to be located on each packaging carton.

**RENEWAL** of this NOA shall be considered after a renewal application has been filed and there has been no change in the applicable building code negatively affecting the performance of this product.

**TERMINATION** of this NOA will occur after the expiration date or if there has been a revision or change in the materials, use, and/or manufacture of the product or process. Misuse of this NOA as an endorsement of any product, for sales, advertising or any other purposes shall automatically terminate this NOA. Failure to comply with any section of this NOA shall be cause for termination and removal of NOA.

**ADVERTISEMENT:** The NOA number preceded by the words Miami-Dade County, Florida, and followed by the expiration date may be displayed in advertising literature. If any portion of the NOA is displayed, then it shall be done in its entirety.

**INSPECTION:** A copy of this entire NOA shall be provided to the user by the manufacturer or its distributors and shall be available for inspection at the job site at the request of the Building Official.

This NOA **revises and renews NOA # 23-0210.02** and consists of this page 1 and evidence pages E-1, E-2 and E-3, as well as approval document mentioned above.

The submitted documentation was reviewed by **Sifang Zhao, P.E.**



*S. Z.*

04/11/2024

NOA No: 24-0213.06  
Expiration Date: July 30, 2030  
Approval Date: April 11, 2024  
Page 1

**NOTICE OF ACCEPTANCE: EVIDENCE SUBMITTED**

**1. EVIDENCE SUBMITTED UNDER PREVIOUS NOAs**

**A. DRAWINGS**

1. Drawing No. **NU-2**, titled “NVTA and NVTAS, NVBH 24 and NVUH 26, NVRT and NVTH”, sheets 1 through 4 of 4, dated 06/25/2020, prepared by Nu-Vue Industries, Inc., signed and sealed by Vipin N. Tolat, P.E. *“Submitted under NOA No. 20-0519.03”*

**B. TEST “Submitted under NOA No. 05-0701.04”**

Test reports on wood connectors per ASTM D1761 by Product Testing, Inc., signed and sealed by C. R. Caudel, P.E. and S. E. Black, P.E.

	<b><u>Report No.</u></b>	<b><u>Wood Connector</u></b>	<b><u>Direction</u></b>	<b><u>Date</u></b>
1.	PT 02-4073	NVTA	Upward	11/06/02
2.	PT 02-4075	NVTA	Upward	11/07/02
3.	PT 02-4074	NVTA	Upward	11/06/02
4.	PT 02-3938	NVTA	Upward	08/06/02
5.	PT 03-4177	NVRT36	Upward	02/03/03
6.	PT 03-4202	NVRT36-T	Upward	02/19/03
7.	PT 03-4271	NVRT36-T	Upward	03/27/03
8.	PT 03-4270	NVRT24-T	Upward	03/27/03
9.	PT 02-4095	NVUH26	Up & Downward	01/17/03
10.	PT 02-4096	NVBH24	Up & Downward	12/03/02
11.	31-22456.0002	NVTA & NVTAS	Lateral	07/06/02
12.	PT 04-4698	NVTH24	Upward Parallel/Perpendicular	04/15/04
13.	PT 04-5036	NVTH24	Upward Load	12/10/04

**C. CALCULATIONS “Submitted under NOA No. 04-1202.01”**

Report of Design Capacities prepared by Vipin N. Tolat, P.E.

	<b><u>Product Model</u></b>	<b><u>No. of Pages</u></b>	<b><u>Date</u></b>	<b><u>Signature</u></b>
1.	NVBM24	7 through 8	05/05/03	V. N. Tolat, P.E.
2.	NVRT	9 through 14	05/05/03	V. N. Tolat, P.E.
3.	NVTA & NVTAS	1 through 6	05/05/03	V. N. Tolat, P.E.
4.	NVTA & NVTAS	1 through 14	02/06/03	V. N. Tolat, P.E.
5.	NVRT	15 through 15	07/07/03	V. N. Tolat, P.E.

6. Verification calculations for compliance with the ASTM D7147-05 and ASTM D7147-11 prepared by Vipin N. Tolat, P.E. dated 04/28/2020, signed and sealed by Vipin N. Tolat, P.E. *“Submitted under NOA No. 20-0519.03”*

**D. QUALITY ASSURANCE**

1. Miami-Dade Department of Regulatory and Economic Resources (RER)

**E. MATERIAL CERTIFICATIONS**

1. None.



---

**Sifang Zhao, P.E.**  
**Product Control Examiner**  
**NOA No: 24-0213.06**  
**Expiration Date: July 30, 2030**  
**Approval Date: April 11, 2024**

**NOTICE OF ACCEPTANCE: EVIDENCE SUBMITTED**

**F. STATEMENTS**

1. Statement letter of code conformance to 2010 and 5<sup>th</sup> (2014) edition of the FBC, issued by Vipin N. Tolat, P.E., dated 04/29/2015, signed and sealed by Vipin N. Tolat, P.E.
2. No Financial Interest and code compliance letter issued by Vipin N. Tolat, P.E., on 03/26/2003 signed and sealed by Vipin N. Tolat, P.E.  
*“Submitted under NOA No. 04-1202.01”*
3. Statement letter of code conformance to the 5<sup>th</sup> Edition (2014) and 6<sup>th</sup> Edition (2017) FBC and of no financial interest, issued by Vipin N. Tolat, P.E., dated 07/25/2017, signed and sealed by Vipin N. Tolat, P.E. *“Submitted under NOA No. 17-0802.09”*
4. Statement letter of code conformance to the 6<sup>th</sup> Edition (2017) and the 7<sup>th</sup> Edition (2020) FBC and of no financial interest, issued by Vipin N. Tolat, P.E., dated 06/25/2020, signed and sealed by Vipin N. Tolat, P.E.  
*“Submitted under NOA No. 20-0519.03”*



---

Sifang Zhao, P.E.  
Product Control Examiner  
NOA No: 24-0213.06  
Expiration Date: July 30, 2030  
Approval Date: April 11, 2024

**NOTICE OF ACCEPTANCE: EVIDENCE SUBMITTED**

**2. EVIDENCE SUBMITTED under NOA#23-0210.02 and newer**

**A. DRAWINGS**

1. Drawing No. **JA-1958.-22**, titled “NOA No. 20-0519.03 Revision”, sheets 1 through 5 of 5, dated 01/03/2023, prepared by Javad Ahmad PE, Inc., signed and sealed by Javad Ahmad, P.E. on 04/11/2023. *“Submitted under NOA No. 23-0210.02”*
2. Drawing No. **JA-2029-23**, titled “SERIES NVTA, NVTAS, NVBH, NVUH, NVRT AND NVTH STEEL WOOD CONNECTORS”, sheets 1 through 5 of 5, dated 01/11/2024, prepared by Javad Ahmad PE, Inc., signed and sealed by Javad Ahmad, P.E. on 02/06/24. *“Submitted under NOA No. 24-0213.06”*

**B. TESTS**

1. None.

**C. CALCULATIONS**

1. Allowable loads calculations, prepared by Javad Ahmad PE, Inc., dated 04/11/2023, signed and sealed by Javad Ahmad, P.E. *“Submitted under NOA No. 23-0210.02”*
2. Allowable loads calculations, prepared by Javad Ahmad PE, Inc., dated 01/23/2024, signed and sealed by Javad Ahmad, P.E. *“Submitted under NOA No. 24-0213.06”*

**D. QUALITY ASSURANCE**

1. Miami-Dade Department of Regulatory and Economic Resources (RER).

**E. MATERIAL CERTIFICATIONS**

1. None.

**F. STATEMENT**

1. Statement letter of code conformance to the 7<sup>th</sup> Edition (2020) of the FBC and of no financial interest, issued by Javad Ahmad PE, Inc., dated 02/03/2023, signed and sealed by Javad Ahmad, P.E. *“Submitted under NOA No. 23-0210.02”*
2. Statement letter of code conformance to the 8<sup>th</sup> Edition (2023) of the FBC and of no financial interest, issued by Javad Ahmad PE, Inc., dated 01/23/2024, signed and sealed by Javad Ahmad, P.E. *“Submitted under NOA #24-0213.06”*



---

Sifang Zhao, P.E.  
Product Control Examiner  
NOA No: 24-0213.06  
Expiration Date: July 30, 2030  
Approval Date: April 11, 2024

# NU-VUE INDUSTRIES, INC.

1055 EAST 29TH HIALEAH, FL 33013, TEL. 305-694-0397

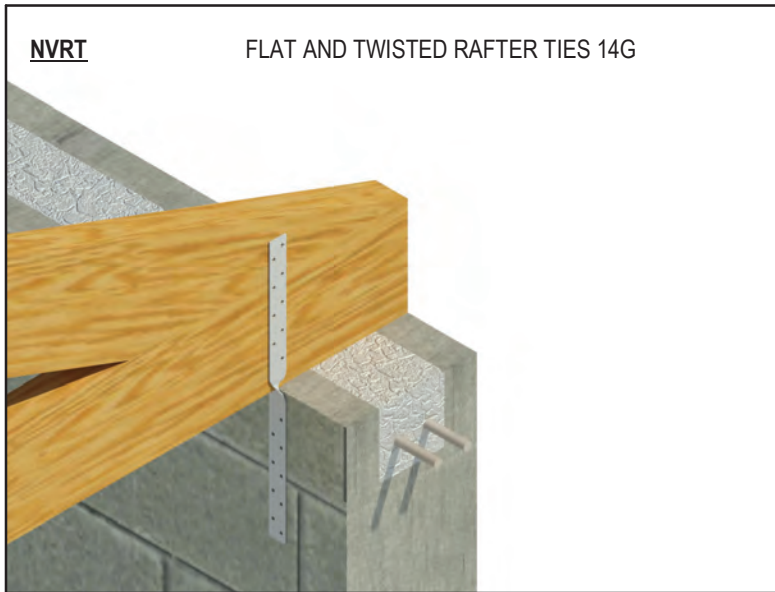

**NVRT** FLAT AND TWISTED RAFTER TIES 14G

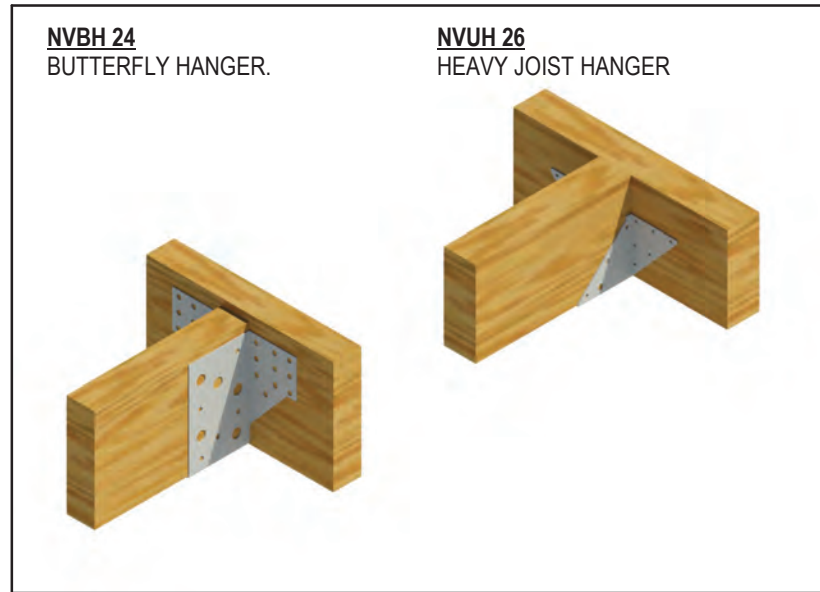

**NVBH 24** BUTTERFLY HANGER. **NVUH 26** HEAVY JOIST HANGER

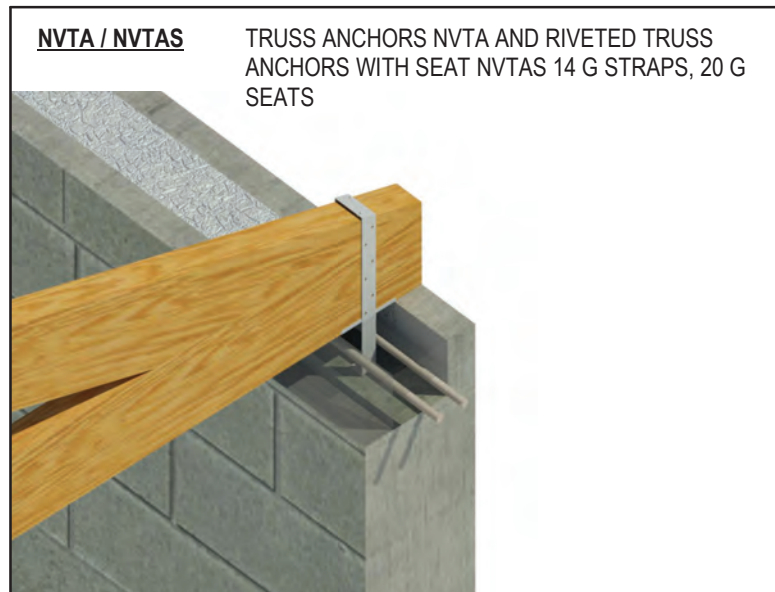

**NVTA / NVTAS** TRUSS ANCHORS NVTA AND RIVETED TRUSS ANCHORS WITH SEAT NVTAS 14 G STRAPS, 20 G SEATS

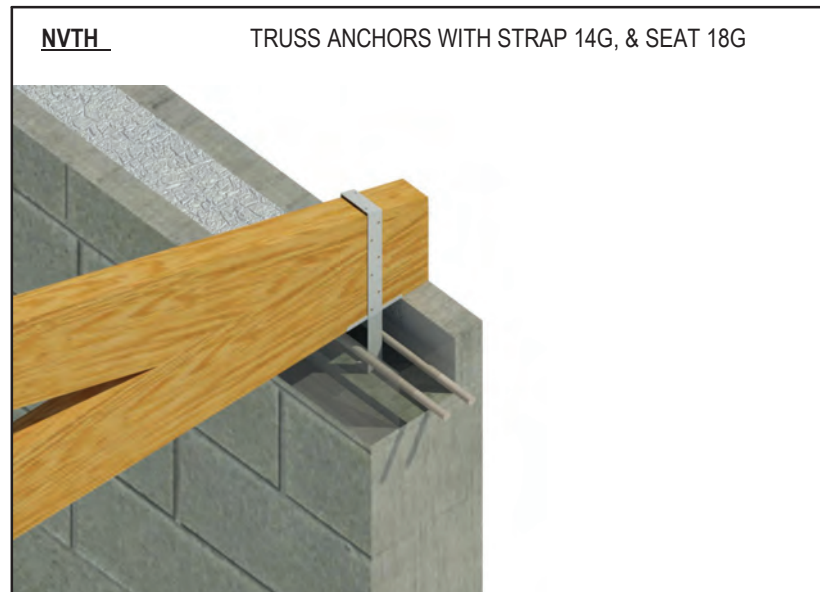

**NVTH** TRUSS ANCHORS WITH STRAP 14G, & SEAT 18G

## MATERIAL

- WOOD**  
WOOD MEMBERS MUST BE S.P. NO. 1, SPECIFIC GRAVITY 0.55 OR AN APPROVED MEMBER WITH AN EQUIVALENT GRADE. DESIGN LOADS FOR OTHER SPECIES SHALL BE ADJUSTED PER NDS 2018. WOOD MEMBERS SHALL HAVE A MOISTURE CONTENT NOT EXCEEDING 19 PERCENT (16 PERCENT FOR STRUCTURAL ENGINEERED LUMBER). WOOD MEMBERS MUST BE USED UNDER CONTINUOUSLY DRY CONDITIONS AND WHERE SUSTAINED TEMPERATURES ARE LIMITED TO 100° F.
- PRESERVATIVE AND FIRE RETARDANT WOOD**  
CONNECTORS OR FASTENERS USED IN CONTACT WITH PRESERVATIVE-TREATED AND FIRE-RETARDANT-TREATED WOOD SHALL BE IN ACCORDANCE WITH SECTION 2304.10.5.
- NAIL**  
NAILS SHALL MEET THE REQUIREMENTS IN TABLE AND THE REQUIREMENTS SPECIFIED IN ASTM F 1667.
- GFCMU MASONRY**  
MATERIAL AND QUALITY OF MASONRY CONSTRUCTION MUST COMPLY WITH THE APPLICABLE SECTIONS OF FBC 2023. MINIMUM CONCRETE OR GROUT COMPRESSIVE STRENGTH SHALL BE 1500 PSI. CONCRETE MASONRY SHALL COMPLY WITH ASTM C90
- CONCRETE**  
MINIMUM CONCRETE COMPRESSIVE STRENGTH SHALL BE 2500 PSI.
- STEEL**  
CONNECTOR STEEL SHALL CONFORM TO ASTM A653 SS GRADE 33, MIN. YIELD 33 KSI, MIN. TENSILE STRENGTH 45 KSI AND MIN. GALVANIZED COATING OF G 60 PER ASTM A653.

## GENERAL NOTES:

- ALLOWABLE LOADS AND ALL FASTENERS ARE BASED ON NATIONAL DESIGN SPECIFICATIONS (NDS) FOR WOOD CONSTRUCTION 2018.
- DESIGN LOADS ARE BASED ON SOUTHERN YELLOW PINE WOOD SPECIES WITH A SPECIFIC GRAVITY OF 0.55. ALLOWABLE LOADS FOR OTHER SPECIES OR CONDITIONS MUST BE ADJUSTED ACCORDING TO NDS 2018.
- THIS CATALOG REFLECTS DESIGN CHANGES AND DESIGN ADJUSTMENTS TO SOME NU-VUE PRODUCTS. THE TABLES AND NOTES IN THIS CATALOG SUPERCEDE ALL PREVIOUS DOCUMENTS. NU-VUE RESERVES THE RIGHT TO CHANGE DESIGN SPECIFICATIONS WITHOUT NOTICE AND IS NOT LIABLE FOR SUCH CHANGES.
- DESIGN LOADS DO NOT INCLUDE 33% INCREASE FOR STEEL AND CONCRETE.
- ALLOWABLE UPLIFT LOADS HAVE BEEN ADJUSTED FOR LOAD DURATION FACTOR CD OF 1.6. APPLICABLE TO WIND AND EARTHQUAKE LOAD PER NDS 2018.
- DESIGN CONFORMS TO 2023 EDITION OF FLORIDA BUILDING CODE AND NDS 2018.
- COMBINED LOAD OF UPLIFT, LI AND L2 SHALL SATISFY THE FOLLOWING EQUATION.  
$$\frac{\text{ACTUAL UPLIFT}}{\text{ALLOWABLE UPLIFT}} + \frac{\text{ACTUAL L1}}{\text{ALLOWABLE L1}} + \frac{\text{ACTUAL L2}}{\text{ALLOWABLE L2}} \leq 1.0$$
- ALL TESTS HAVE BEEN CONDUCTED IN ACCORDANCE WITH ASTM D-1761.
- THE DESIGN LOADS LISTED ARE BASED ON THE LEAST VALUE OF THE FOLLOWING:
  - THE LOWEST ULTIMATE LOAD DIVIDED BY THREE.
  - THE LOWEST LOAD PRODUCING 1/8" DEFLECTION.
  - CALCULATIONS BASED ON NDS, AISI AND OTHER APPLICABLE CODES.

## REFERENCES:

- AISC 360-16
- AISI S100-16 COLD FORMED STEEL
- FBC 2023
- ACI 318-19



**JAVAD AHMAD PE, inc**  
8800 NW 23rd St, Miami FL 33172  
Ph: (305) 424-8001  
support@ja-pe.com

CONSULTING • STRUCTURAL DESIGN • FACADES • BUILDING ENVELOPE • SYSTEM DESIGN • PRODUCT APPROVALS

SERIES NVTA, NVTAS, NVBH, NVUH, NVTH, NVRT AND NVTH STEEL WOOD CONNECTORS

**NU-VUE INDUSTRIES INC.**

1055 East 29th Street  
Hialeah, FL. 33013

drawing no.	date:	REVISION	
		DATE	DESCRIPTION
JA-2029-23	01/11/2024		

**PRODUCT REVISED**  
as complying with the Florida Building Code  
NOA-No. 24-0213.06  
Expiration Date 07/30/2030  
By   
Miami-Dade Product Control

Digitally Signed  
Javad Ahmad  
#70592  
Date 2024.02.06 11:41:34 -05'00'

# NVTA & NVTAS

**TABLE 1**

NVTA STRAP				
H LENGTH (in)	PRODUCT CODE		GAUGE SEAT	GAUGE STRAP
16	NVTA-16	NVTAS-212	20	14
18	NVTA-18	NVTAS-214	20	14
20	NVTA-20	NVTAS-216	20	14
22	NVTA-22	NVTAS-218	20	14
24	NVTA-24	NVTAS-220	20	14
26	NVTA-26	NVTAS-222	20	14
28	NVTA-28	NVTAS-224	20	14
30	NVTA-30	NVTAS-226	20	14
36	NVTA-36	NVTAS-232	20	14
48	NVTA-48	NVTAS-244	20	14

**TABLE 2**

NO. OF FASTENERS EACH STRAP	MAXIMUM ALLOWABLE LOAD (lbs.)			
	UPLIFT SINGLE STRAP	UPLIFT DOUBLE STRAPS	L1 SINGLE & DOUBLE STRAP	L2 SINGLE & DOUBLE STRAP
5	757	1514	250	500
6	805	1610	250	500
7	854	1708	250	500
8	902	**1804	250	500
9	851	**1902	250	500
10	999	**1998	250	500
11	1048	**2096	250	500
12	1096	**2192	250	500
13	1145	**2290	250	500
14	1193	**2290	250	500

**TABLE 3**

NO. OF FASTENERS EACH STRAP 10d X 1.5"	MAXIMUM ALLOWABLE LOAD (lbs.)			
	UPLIFT SINGLE STRAP	UPLIFT DOUBLE STRAPS	L1 SINGLE & DOUBLE STRAPS	L2 SINGLE & DOUBLE STRAPS
5	1032	2236	256	500
6	1127	2254	385	565
7	1136	2272	520	630
8	1144	**2288	520	630
9	1153	**2306	520	630
10	1161	**2322	520	630
11	1170	**2340	520	630
12	1178	**2356	520	630
13	1187	**2374	520	630

**NOTES:**

- SEE GENERAL NOTES, SHEET 1.
- \*\* FOR 8 OR MORE NAILS PER STRAP, USE DOUBLE TRUSS FOR DOUBLE STRAPS

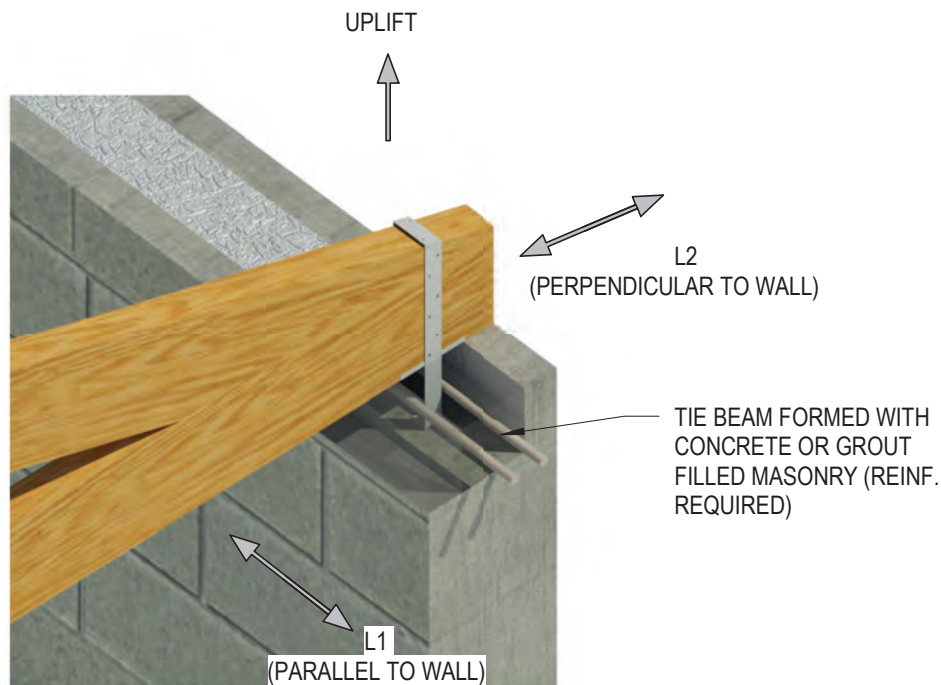

**INSTALLATION**

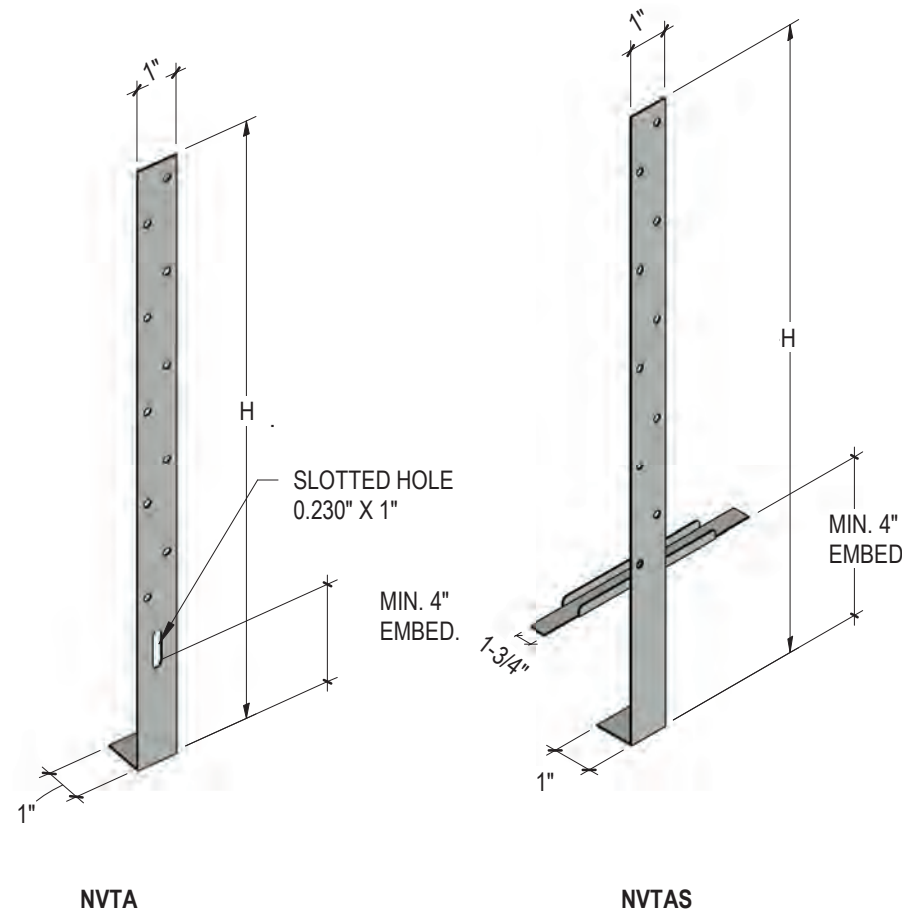

**NVTA**

**NVTAS**

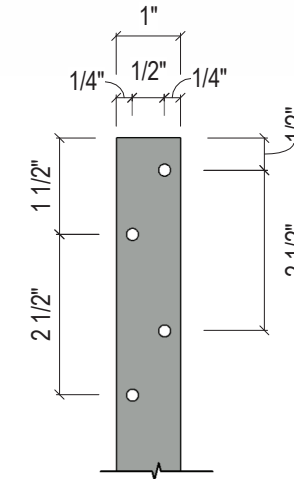

**NVTA / NVTAS HOLE DIA. 3/16"**

**PRODUCT REVISED**  
 as complying with the Florida Building Code  
 NOA-No. 24-0213.06  
 Expiration Date 07/30/2030  
 By *[Signature]*  
 Miami-Dade Product Control



**JAVAD AHMAD PE, inc**  
 8800 NW 23rd St, Miami FL 33172  
 Ph: (305) 424-8001  
 support@ja-pe.com

SERIES NVTA, NVTAS, NVBH, NVUH, NVRT AND NVTH STEEL WOOD CONNECTORS

**NU-VUE INDUSTRIES INC.**  
 1055 East 29th Street  
 Hialeah, FL. 33013

AG	BS	REVISION	DESCRIPTION
drawn by:	check by:		BY
JA-2029-23	01/11/2024	No.	

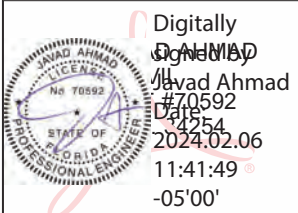

CONSULTING • STRUCTURAL DESIGN • BUILDING ENVELOPE • FACADES • SYSTEM DESIGN • PRODUCT APPROVALS

# NVBH & NVUH

**TABLE 4**

NVBH 24 BUTTERFLY HANGER						
SIZE	PRODUCT CODE	STEEL GAUGE	FASTENERS (8d)		ALLOWABLE LOADS (lbs.)	
			HEADER	JOIST	DOWNWARD GRAVITY LOADS	WIND UPLIFT LOADS
2X4	NVBH 24	18	12	6	1113	364*

**NOTES:**

- USE ALL SPECIFIED FASTENERS IN SCHEDULE TO ACHIEVE VALUES INDICATED.
- VALUES ARE BASED ON 1-1/2" HEADER & JOIST THICKNESS.
- \* CAN BE USED ONLY IN NON-HVHZ
- SEE GENERAL NOTES, SHEET 1

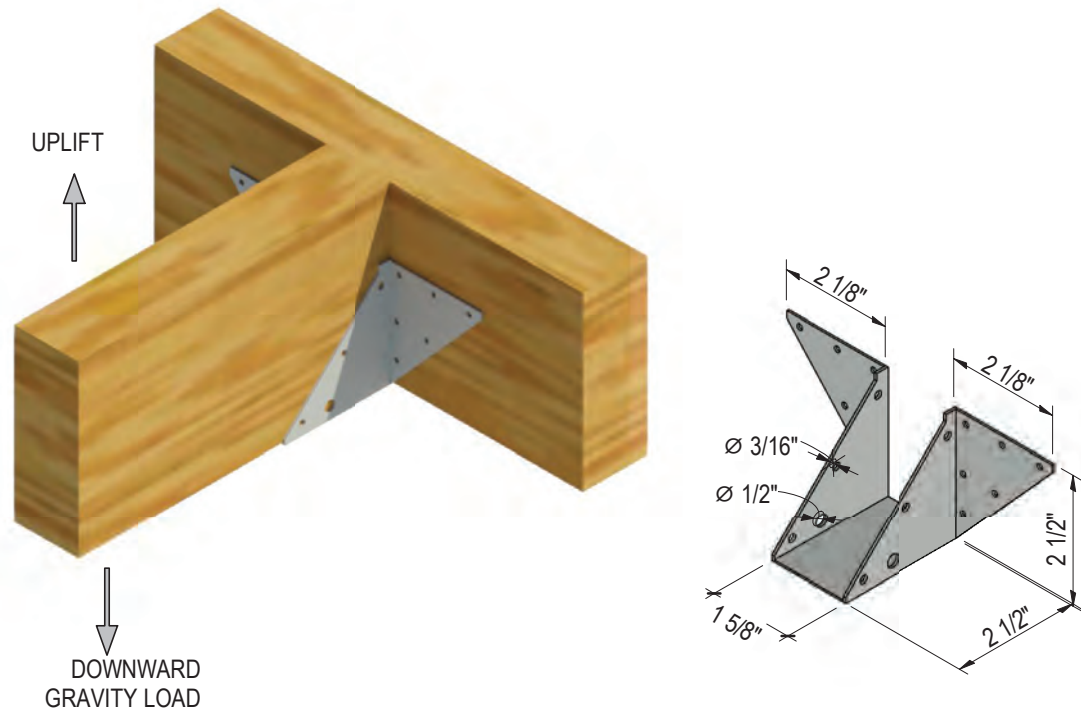
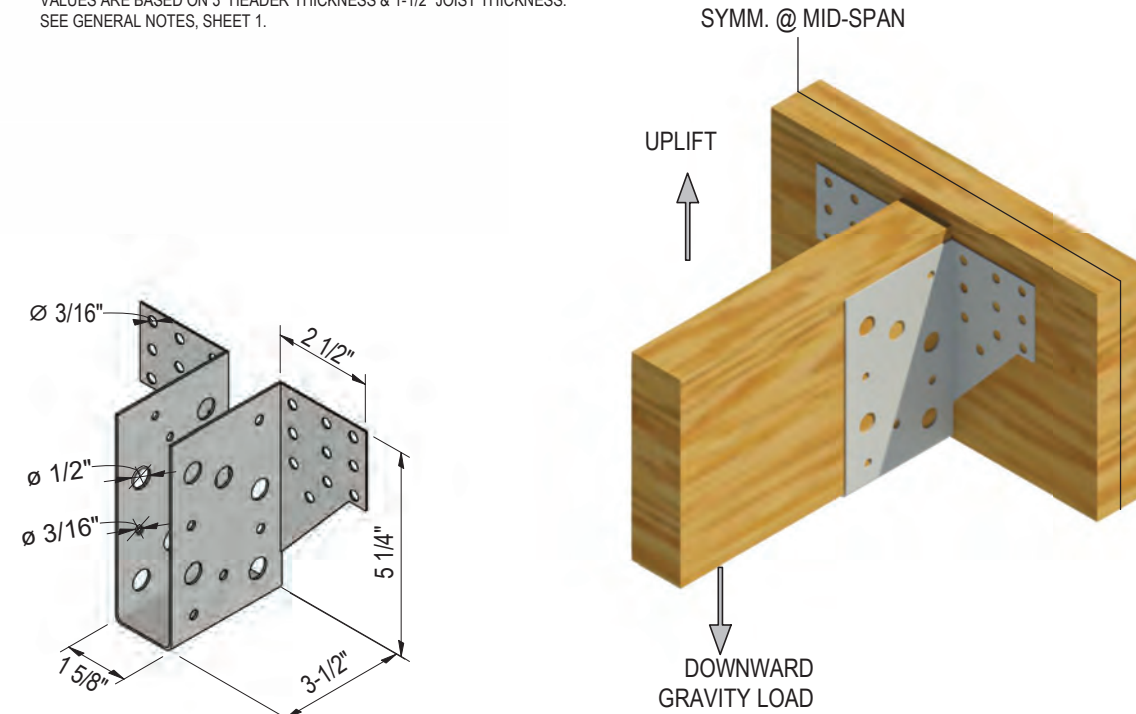

**TABLE 5**

NVUH 26 JOIST HANGER						
SIZE	PRODUCT CODE	STEEL GAUGE	FASTENER SCHEDULE		ALLOWABLE LOADS (lbs)	
			HEADER 16d	JOIST 10d x 1-1/2"	DOWNWARD GRAVITY LOADS	WIND UPLIFT LOAD
2X6	NVUH 26	14	20	10	2233	1213

**NOTES:**

- USE ALL SPECIFIED FASTENERS IN SCHEDULE TO ACHIEVE VALUES INDICATED.
- VALUES ARE BASED ON 3" HEADER THICKNESS & 1-1/2" JOIST THICKNESS.
- SEE GENERAL NOTES, SHEET 1.



**PRODUCT REVISED**  
 as complying with the Florida  
 Building Code  
 NOA-No. 24-0213.06  
 Expiration Date 07/30/2030  
 By *[Signature]*  
 Miami-Dade Product Control



**JAVAD AHMAD PE, inc**  
 8800 NW 23rd St, Miami FL  
 33172  
 Ph: (305) 424-8001  
 support@ja-pe.com

CONSULTING • STRUCTURAL DESIGN • FACADES • BUILDING ENVELOPE • SYSTEM DESIGN • PRODUCT APPROVALS

SERIES NVTA, NVTAS, NVBH, NVUH, NVUH, NVRT  
 AND NVTH STEEL WOOD CONNECTORS

**NU-VUE INDUSTRIES INC.**  
 1055 East 29th Street  
 Hialeah, FL. 33013

AG	BS	REVISION	DESCRIPTION
drawn by:	check by:		
JA-2029-23	01/11/2024	BY	
drawing no.	date:	DATE	
		No.	

Digitally  
 Signed  
 Javad Ahmad  
 #70592  
 Date  
 2024.02.06  
 11:41:59  
 -05'00'

AG	BS
drawn by:	check by:
JA-2029-23	01/11/2024
drawing no.	date:
No.	No.

REVISION	DESCRIPTION
	BY DATE
No.	No.

Digitally  
 Drawn by  
 Javad Ahmad  
 No. 70592  
 Date  
 2024.02.06  
 11:42:11  
 -05'00'

**TABLE 6**

PRODUCT CODE	LENGTH	GAUGE	FASTENERS (16d or 10d 1 1/2" NAILS)		MAXIMUM UPLIFT (lbs)	
			IN EACH MEMBER*	TOTAL	FLAT TIES	TWISTED TIES
NVRT-12	12	14	3	6	**588	**588
NVRT-16	16	14	4	8	725	724
NVRT-18	18	14	5	10	861	860
NVRT-20	20	14	6	12	998	996
NVRT-22	22	14	7	14	1135	1132
NVRT-24	24	14				
NVRT-30	30	14				
NVRT-36	36	14				
NVRT-48	48	14				

**NOTES:**

- SPECIFY "F" FOR FLAT AND "T" FOR TWISTED WHEN ORDERING
- \* INDICATES NO. OF NAILS IN EACH CONNECTED WOOD MEMBERS.
- \*\* USE ONLY IN NON-HVHZ
- FASTNER VALUES ARE BASED ON A MINIMUM OF 1-1/2" THICK WOOD MEMBERS.
- ALL TAPCONS MUST BE IN THE SAME ROW SPACED AT 1-1/2" ON CENTERS. DO NOT USE HOLES IN OPPOSITE ROW. STRAP MUST BE LONG ENOUGH TO ACCOMMODATE REQUIRED TAPCONS.
- ITW TAPCONS SHALL BE EMBEDDED A MINIMUM OF 1-1/4" INTO CONCRETE TIE BEAM OR GROUT FILLED MASONRY TIE BEAM, ITW TAPCONS HAVE A MINIMUM EDGE DISTANCE OF 2-1/2" AND MINIMUM STAGGERED SPACING OF 1-1/2" AS SHOWN.
- SEE GENERAL NOTES, SHEET 01

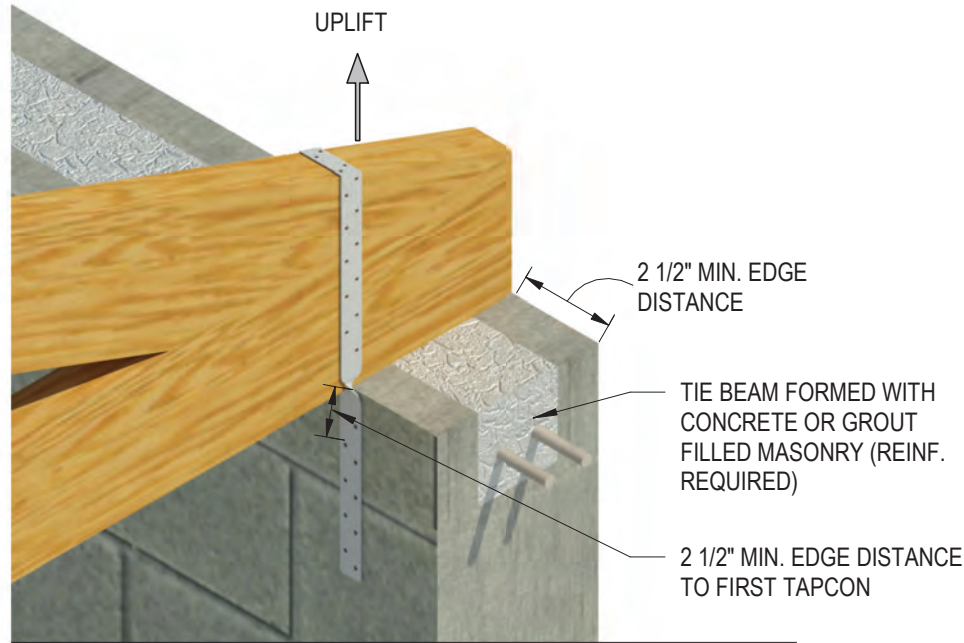

**INSTALLATION - WOOD TO CONCRETE / MASONRY**

**TABLE 7**

PRODUCT CODE	DIMENSIONS		16d NAILS TO WOOD FRAMING	1/4" DIA. TAPCONS TO CONCRETE	MAXIMUM UPLIFT LOAD
	LENGTH	GAUGE			
NVRT-12	12	14	3	3	**588
NVRT-16	16	14	4	6	723
NVRT-18	18	14	5	7	857
NVRT-20	20	14	6	8	991
NVRT-22	22	14	7	9	1125
NVRT-24	24	14			
NVRT-30	30	14			
NVRT-36	36	14			
NVRT-48	48	14			

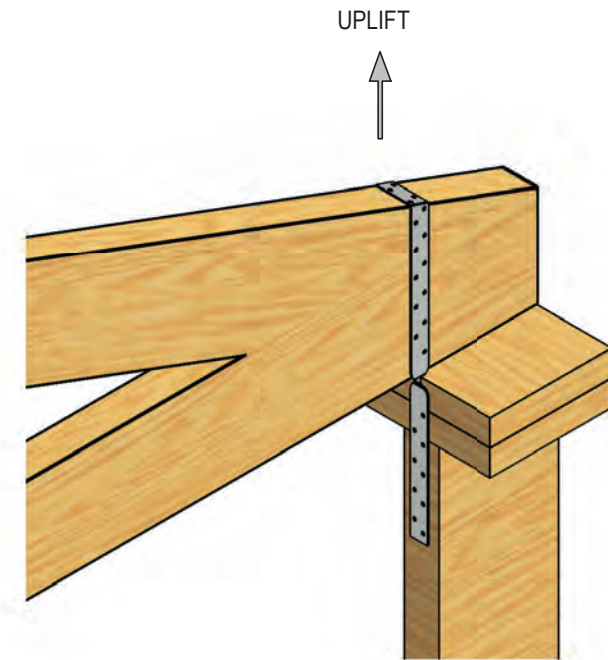

**INSTALLATION - WOOD TO WOOD**

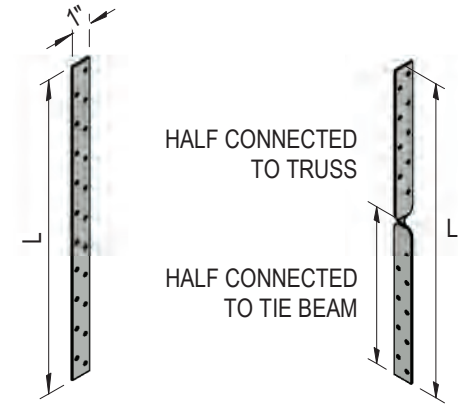

**PERSPECTIVE VIEW**

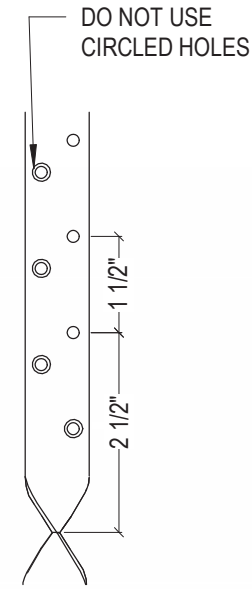

**SEE NOTE #3**

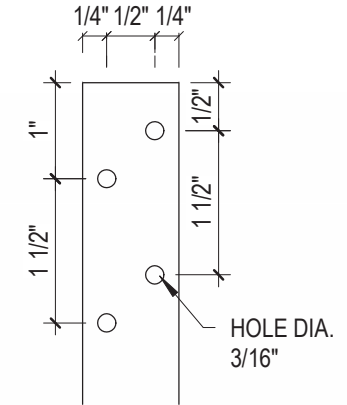

**FRONT VIEW**

**PRODUCT REVISED**  
 as complying with the Florida  
 Building Code  
 NOA-No. 24-0213.06  
 Expiration Date 07/30/2030

By  
 Miami-Dade Product Control



# NVTH - TRUSS ANCHOR

**NOTES:**

1. SEE GENERAL NOTES, SHEET 1

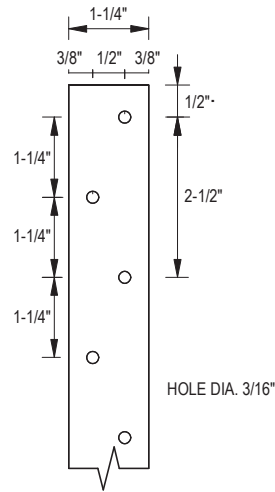

FRONT VIEW

**TABLE 8**

PRODUCT CODE	H	GAUGE	
	LENGTH(IN)	SEAT	STRAP
NVTH-16	12	18	14
NVTH-18	14	18	14
NVTH-20	16	18	14
NVTH-22	18	18	14
NVTH-24	20	18	14
NVTH-26	22	18	14
NVTH-28	24	18	14
NVTH-30	26	18	14
NVTH-36	32	18	14
NVTH-48	44	18	14

**TABLE 9**

NO. OF FASTNERS IN EACH STRAP 10d x1-1/2"	MAXIMUM UPLIFT LOADS (lbs)		MAXIMUM LATERAL LOADS (lbs)			
	SINGLE STRAP ON SINGLE TRUSS	DOUBLE STRAP ON DOUBLE TRUSS	SINGLE STRAP		DOUBLE STRAP	
			L1	L2	L1	L2
5	1032	2064	560	525	1120	1050
6	1222	2444	671	630	1342	1260
7	1275	2550	783	735	1566	1470
8	1329	2658	783	735	1566	1470
9	1383	2766	783	735	1566	1470
10	1437	2874	783	735	1566	1470
11	1490	2980	783	735	1566	1470
12	1544	3088	783	735	1566	1470
13	1598	3196	783	735	1566	1470

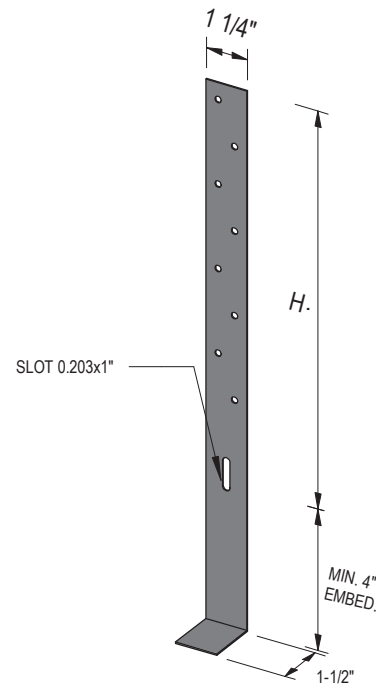

PERSPECTIVE VIEW

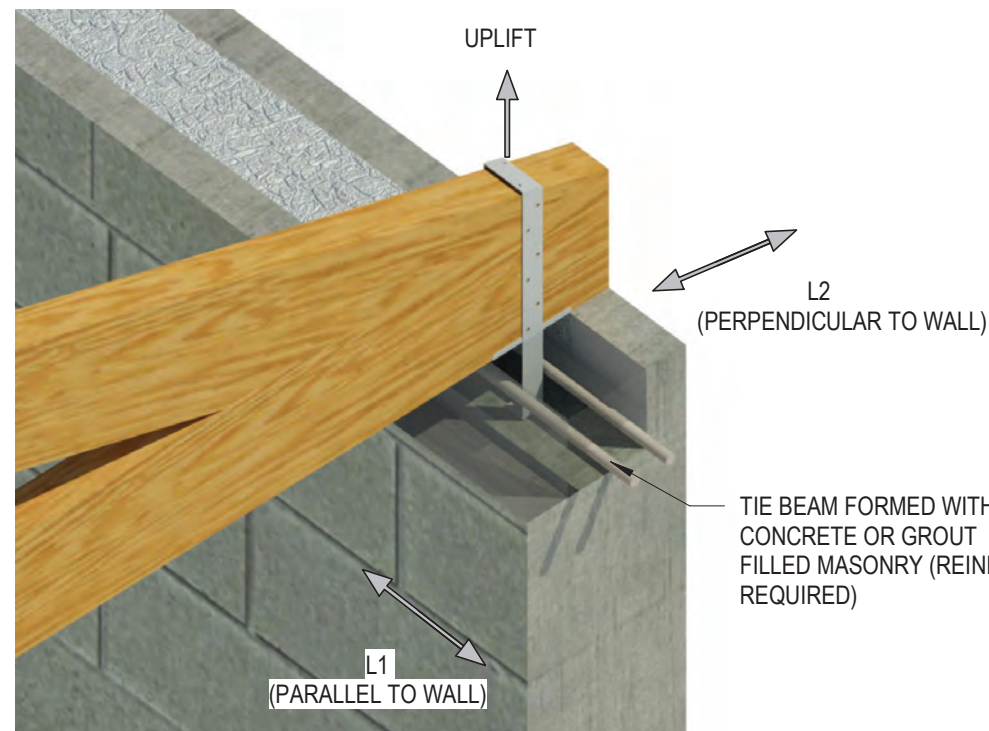

INSTALLATION

5 NAILS IN FRONT (MIN.), NAILS 10d x 1.5"

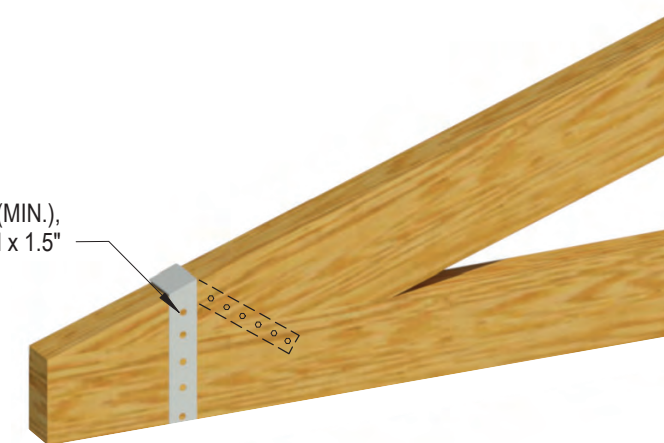

NAILS ON FRONT AND BACK TO BE OFF-CENTRED

**PRODUCT REVISED**  
as complying with the Florida Building Code  
NOA-No. 24-0213.06  
Expiration Date 07/30/2030  
By *[Signature]*  
Miami-Dade Product Control



**JAVAD AHMAD PE, inc**  
8800 NW 23rd St, Miami FL 33172  
Ph: (305) 424-8001  
support@ja-pe.com

SERIES NVTA, NVTAS, NVBH, NVUH, NVRT AND NVTH STEEL WOOD CONNECTORS

**NU-VUE INDUSTRIES INC.**  
1055 East 29th Street  
Hialeah, FL. 33013

AG	BS	REVISION	DESCRIPTION
drawn by:	check by:		
JA-2029-23	01/11/2024	BY	
drawing no.	date:	DATE	
		No.	

Digitally signed by Javad Ahmad #70592 Date: 2024.02.06 11:42:21 -05'00'

CONSULTING • STRUCTURAL DESIGN • FACADES • BUILDING ENVELOPE • SYSTEM DESIGN • PRODUCT APPROVALS