



DEPARTMENT OF REGULATORY AND ECONOMIC RESOURCES (RER)  
BOARD AND CODE ADMINISTRATION DIVISION

MIAMI-DADE COUNTY  
PRODUCT CONTROL SECTION  
11805 SW 26 Street, Room 208  
Miami, Florida 33175-2474  
T (786) 315-2590 F (786) 315-2599

[www.miamidade.gov/economy](http://www.miamidade.gov/economy)

## NOTICE OF ACCEPTANCE (NOA)

**Tremco CPG, Inc.**  
3735 Green Road  
Beachwood, OH 44122

### SCOPE:

This NOA is being issued under the applicable rules and regulations governing the use of construction materials. The documentation submitted has been reviewed and accepted by Miami-Dade County RER- Product Control Section to be used in Miami Dade County and other areas where allowed by the Authority Having Jurisdiction (AHJ).

This NOA shall not be valid after the expiration date stated below. The Miami-Dade County Product Control Section (In Miami Dade County) and/or the AHJ (in areas other than Miami Dade County) reserve the right to have this product or material tested for quality assurance purposes. If this product or material fails to perform in the accepted manner, the manufacturer will incur the expense of such testing and the AHJ may immediately revoke, modify, or suspend the use of such product or material within their jurisdiction. RER reserves the right to revoke this acceptance if it is determined by Miami-Dade County Product Control Section that this product or material fails to meet the requirements of the applicable building code.

This product is approved as described herein and has been designed to comply with the High Velocity Hurricane Zone of the Florida Building Code.

### DESCRIPTION: "TremLock R Steel " .023"(min) Steel Wall Panel

**APPROVAL DOCUMENT:** Drawing No. E, titled " TremLock R Steel Wall Panel 24ga. Details ", sheets 1 through 5 of 5, prepared by Johnathan Green, P.E., dated August 16, 2022, signed and sealed by Johnathan Green, P.E. on August 18, 2022, bearing the Miami-Dade County Product Control Renewal stamp with the Notice of Acceptance number and the expiration date by the Miami-Dade County Product Control Section.

### MISSILE IMPACT RATING: Large and Small Missile Impact Resistant

**LABELING:** Each panel shall bear a permanent label with the manufacturer's name or logo:

1500 Hamilton Road                      9700 Interstate 20                      253 One Georgia Dr.  
Bossier City, LA 71111                      Merkel, TX 79536                      Ashburn, GA 31714

and the following statement: "Miami-Dade County Product Control Approved", unless otherwise noted herein.

**RENEWAL** of this NOA shall be considered after a renewal application has been filed and there has been no change in the applicable building code negatively affecting the performance of this product.

**TERMINATION** of this NOA will occur after the expiration date or if there has been a revision or change in the materials, use, and/or manufacture of the product or process. Misuse of this NOA as an endorsement of any product, for sales, advertising or any other purposes shall automatically terminate this NOA. Failure to comply with any section of this NOA shall be cause for termination and removal of NOA.

**ADVERTISEMENT:** The NOA number preceded by the words Miami-Dade County, Florida, and followed by the expiration date may be displayed in advertising literature. If any portion of the NOA is displayed, then it shall be done in its entirety.

**INSPECTION:** A copy of this entire NOA shall be provided to the user by the manufacturer or its distributors and shall be available for inspection at the job site at the request of the Building Official.

This NOA **renews NOA #22-1024.03** and consists of this page 1, evidence submitted pages E-1, E-2 and E-3 as well as approval document mentioned above.

The submitted documentation was reviewed by **Helmy A. Makar, P.E., M.S.**



*Helmy A. Makar*  
04/04/24

NOA No. 24-0221.01  
Expiration Date: 03/18/2029  
Approval Date: 04/04/2024

**Tremco CPG, Inc.**

**NOTICE OF ACCEPTANCE: EVIDENCE SUBMITTED**

**1. EVIDENCE SUBMITTED UNDER PREVIOUS APPROVAL #13-0716.11**

**A. DRAWINGS**

1. *Drawing No. E, titled " TremLock R Plus 24ga. Details ", sheets 1 through 5 of 5, prepared by Terrence E. Wolfe, P.E., dated November 12, 2013, signed and sealed by Terrence E. Wolfe, P.E. on November 12, 2013.*

**B. TESTS**

1. *See NOA # 14-0102.07.*

**C. CALCULATIONS**

1. *See NOA # 14-0102.07.*

**D. QUALITY ASSURANCE**

1. *By Miami-Dade County Department of Regulatory and Economic Resources.*

**E. MATERIAL CERTIFICATIONS**

1. *See NOA # 14-0102.07.*

**F. STATEMENTS**

1. *Private Labeling Agreement, dated March 26, 2012, signed by Ken Gieseke and Thomas Biller.*

**2. EVIDENCE SUBMITTED UNDER PREVIOUS APPROVAL #18-0928.09**

**A. DRAWINGS**

1. *None.*

**B. TESTS**

1. *See NOA # 18-1015.08.*

**C. CALCULATIONS**

1. *See NOA # 18-1015.08.*

**D. QUALITY ASSURANCE**

1. *By Miami-Dade County Department of Regulatory and Economic Resources.*

**E. MATERIAL CERTIFICATIONS**

1. *See NOA # 18-1015.08.*

**F. STATEMENTS**

1. *Private Labeling Agreement, dated 06/04/2018, signed by Ken Gieseke and Thomas Biller.*
2. *FBC, 2017 Edition compliance letter issued by Force Engineering & Testing, Inc. dated 10/03/18, signed & sealed by T. E. Wolfe, P.E.*



Helmy A. Makar, P.E., M.S.  
Product Control Section Supervisor  
NOA No. 24-0221.01  
Expiration Date: 03/18/2029  
Approval Date: 04/04/2024

**Tremco CPG, Inc.**

**NOTICE OF ACCEPTANCE: EVIDENCE SUBMITTED**

**3. EVIDENCE SUBMITTED UNDER PREVIOUS APPROVAL #22-0228.19**

**A. DRAWINGS**

1. *None.*

**B. TESTS**

1. *See NOA # 20-1215.12*

**C. CALCULATIONS**

1. *See NOA # 20-1215.12*

**D. QUALITY ASSURANCE**

1. *By Miami-Dade County Department of Regulatory and Economic Resources.*

**E. MATERIAL CERTIFICATIONS**

1. *See NOA # 20-1215.12*

**F. STATEMENTS**

1. *Private Labeling Agreement, dated 06/04/18, signed by Ken Gieseke and Thomas Biller.*
2. *FBC, 2020 Edition compliance letter issued by Force Engineering & Testing, Inc. dated 10/03/21, signed & sealed by T. E. Wolfe, P.E.*

**4. EVIDENCE SUBMITTED UNDER PREVIOUS APPROVAL #22-1024.03**

**A. DRAWINGS**

1. *Drawing No. E, titled " TremLock R Steel Wall Panel 24ga. Details ", sheets 1 through 5 of 5, prepared by Johnathan Green, P.E., dated August 16, 2022, signed and sealed by Johnathan Green, P.E. on August 18, 2022.*

**B. TESTS**

1. *See NOA # 20-1215.12*

**C. CALCULATIONS**

1. *See NOA # 20-1215.12*

**D. QUALITY ASSURANCE**

1. *By Miami-Dade County Department of Regulatory and Economic Resources.*

**E. MATERIAL CERTIFICATIONS**

1. *See NOA # 20-1215.12*

**F. STATEMENTS**

1. *Private Labeling Agreement, dated 06/04/2018, signed by Ken Gieseke and Thomas Biller.*
2. *FBC, 2020 Edition compliance letter issued by Force Engineering & Testing, Inc. dated 10/03/21, signed & sealed by Johnathan Green, P.E.*

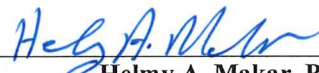
  
\_\_\_\_\_  
Helmy A. Makar, P.E., M.S.  
Product Control Section Supervisor  
NOA No. 24-0221.01  
Expiration Date: 03/18/2029  
Approval Date: 04/04/2024

**Tremco CPG, Inc.**

**NOTICE OF ACCEPTANCE: EVIDENCE SUBMITTED**

**4. NEW EVIDENCE SUBMITTED**

**A. DRAWINGS**

1. *None.*

**B. TESTS**

1. *See NOA # 23-1117.02*

**C. CALCULATIONS**

1. *See NOA # 23-1117.02*

**D. QUALITY ASSURANCE**

1. *By Miami-Dade County Department of Regulatory and Economic Resources.*

**E. MATERIAL CERTIFICATIONS**

1. *See NOA # 23-1117.02*

**F. STATEMENTS**

1. *Private Labeling Agreement, dated 06/04/2018, signed by Ken Gieseke and Thomas Biller.*
2. *FBC, 2023 Edition compliance letter issued by Force Engineering & Testing, Inc. dated 10/03/21, signed & sealed by Johnathan Green, P.E.*

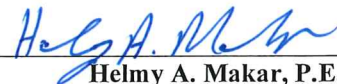

---

**Helmy A. Makar, P.E., M.S.**  
**Product Control Section Supervisor**

**NOA No. 24-0221.01**

**Expiration Date: 03/18/2029**

**Approval Date: 04/04/2024**

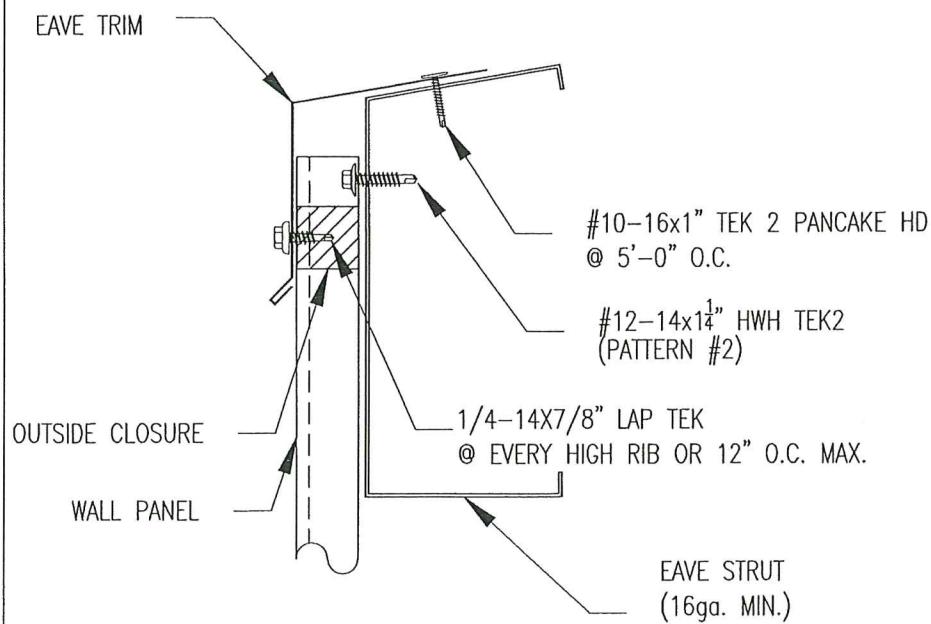

WALL DETAIL @ EAVE

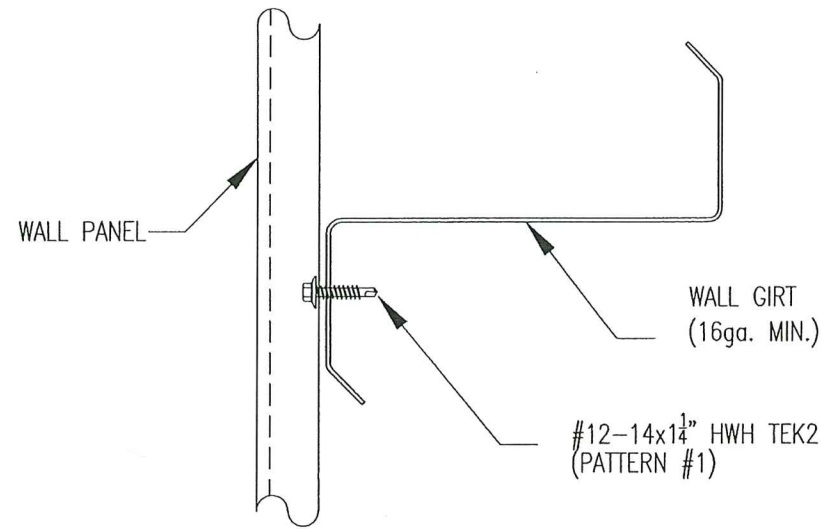

WALL DETAIL @ INTERMEDIATE GIRT

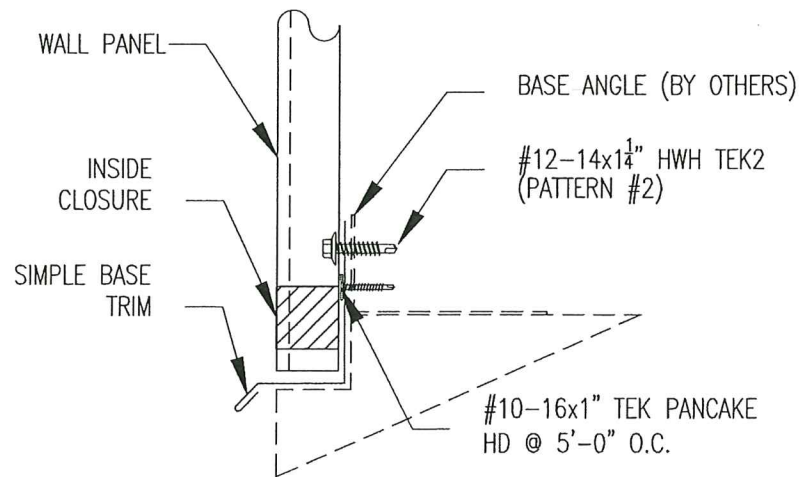

WALL DETAIL @ BASE

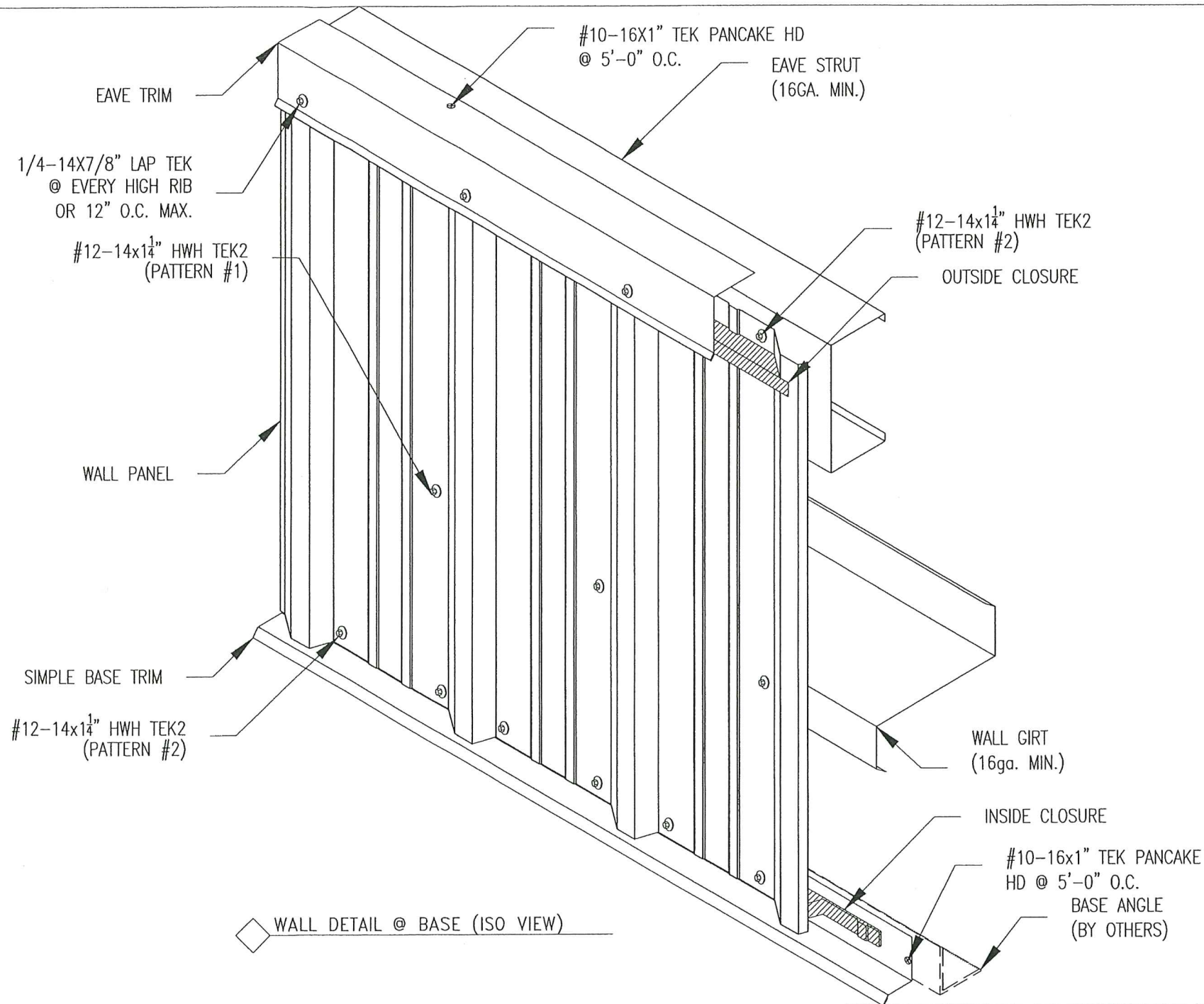

WALL DETAIL @ BASE (ISO VIEW)

THIS ITEM HAS BEEN DIGITALLY SIGNED AND SEALED BY JOHNATHAN GREEN ON THE DATE ADJACENT TO THE SEAL. PRINTED COPIES OF THIS DOCUMENT ARE NOT CONSIDERED SIGNED AND SEALED AND THE SIGNATURE MUST BE VERIFIED ON ANY ELECTRONIC COPIES.

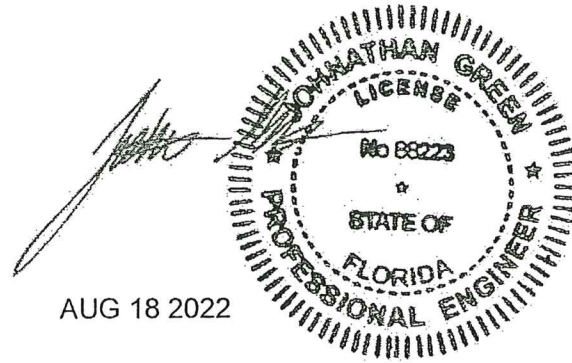

PRODUCT RENEWED as complying with the Florida Building Code  
 Building Code 24-0221.01  
 Acceptance No. 24-0221.01  
 Expiration Date 03/18/2029  
 By Helga A. Miller  
 Miami Code Product Control

PRODUCT REVISED as complying with the Florida Building Code  
 Building Code 22-1024.03  
 Acceptance No. 22-1024.03  
 Expiration Date 03/18/2024  
 By Helga A. Miller  
 Miami Code Product Control

MANUFACTURING ENGINEER JOHNATHAN GREEN, P.E.  
 FLORIDA REGISTRATION NO. 88223

REL.	BY	DESCRIPTION	DATE
	JG	FOR APPROVAL	08-17-22

PROJECT: DADE COUNTY TESTING

SHEET TITLE: TREMLOCK R STEEL WALL PANEL 24ga. DETAILS

LOCATION: DADE COUNTY, FLORIDA

DATE: 08-16-22

SCALE: N.T.S.

PROJECT NUMBER: 13-0716.11

SHEET NUMBER: E1 of 5

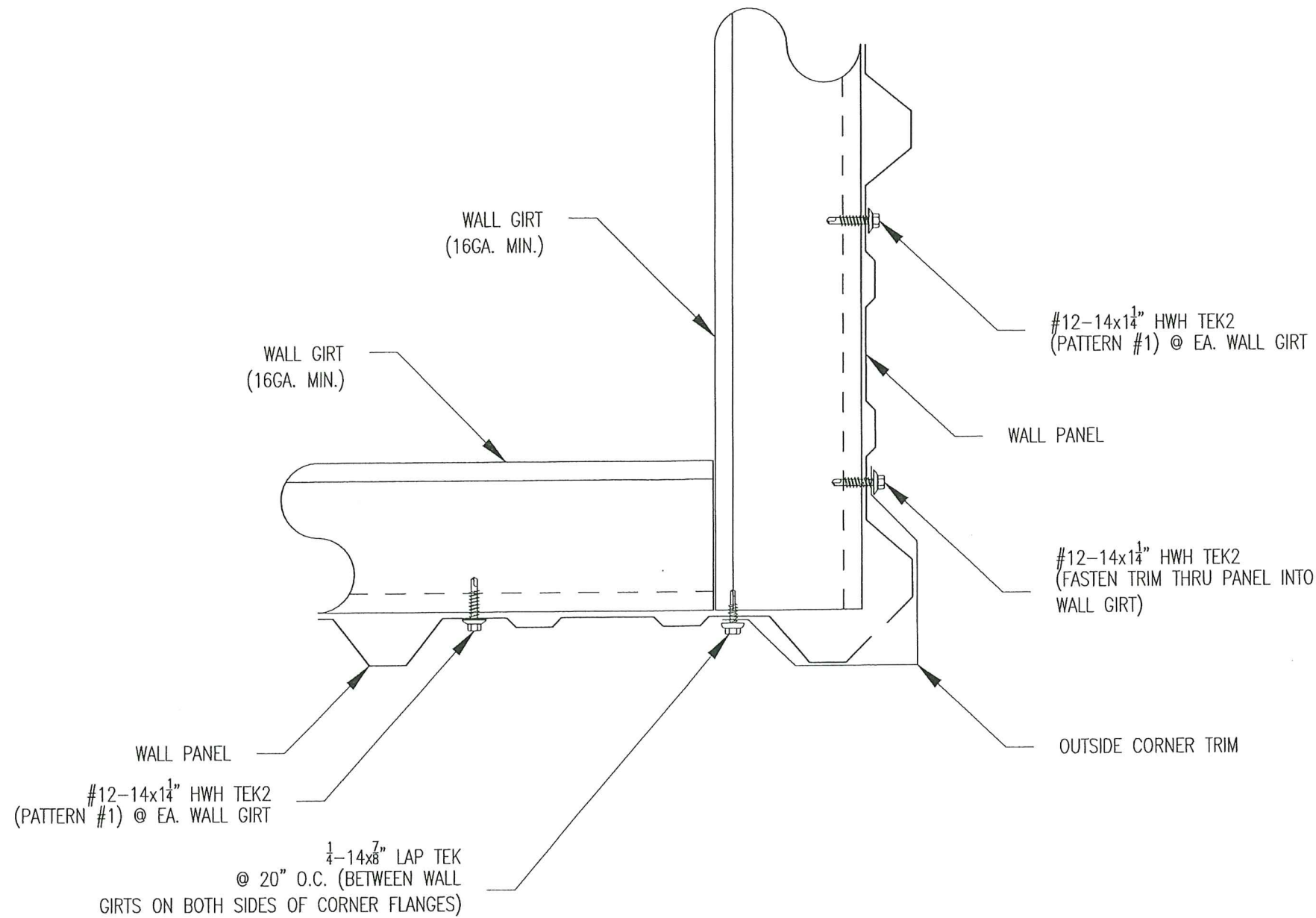

THIS ITEM HAS BEEN DIGITALLY SIGNED AND SEALED BY JOHNATHAN GREEN ON THE DATE ADJACENT TO THE SEAL. PRINTED COPIES OF THIS DOCUMENT ARE NOT CONSIDERED SIGNED AND SEALED AND THE SIGNATURE MUST BE VERIFIED ON ANY ELECTRONIC COPIES.

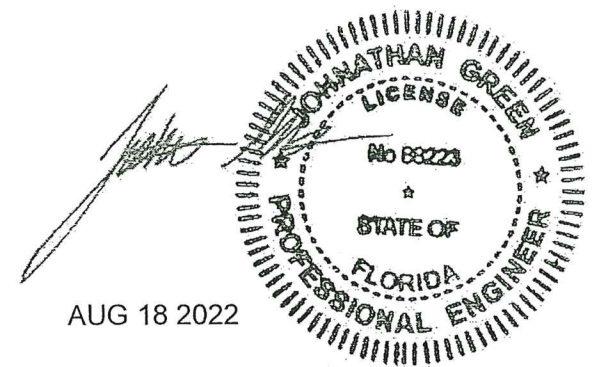

1 OUTSIDE CORNER

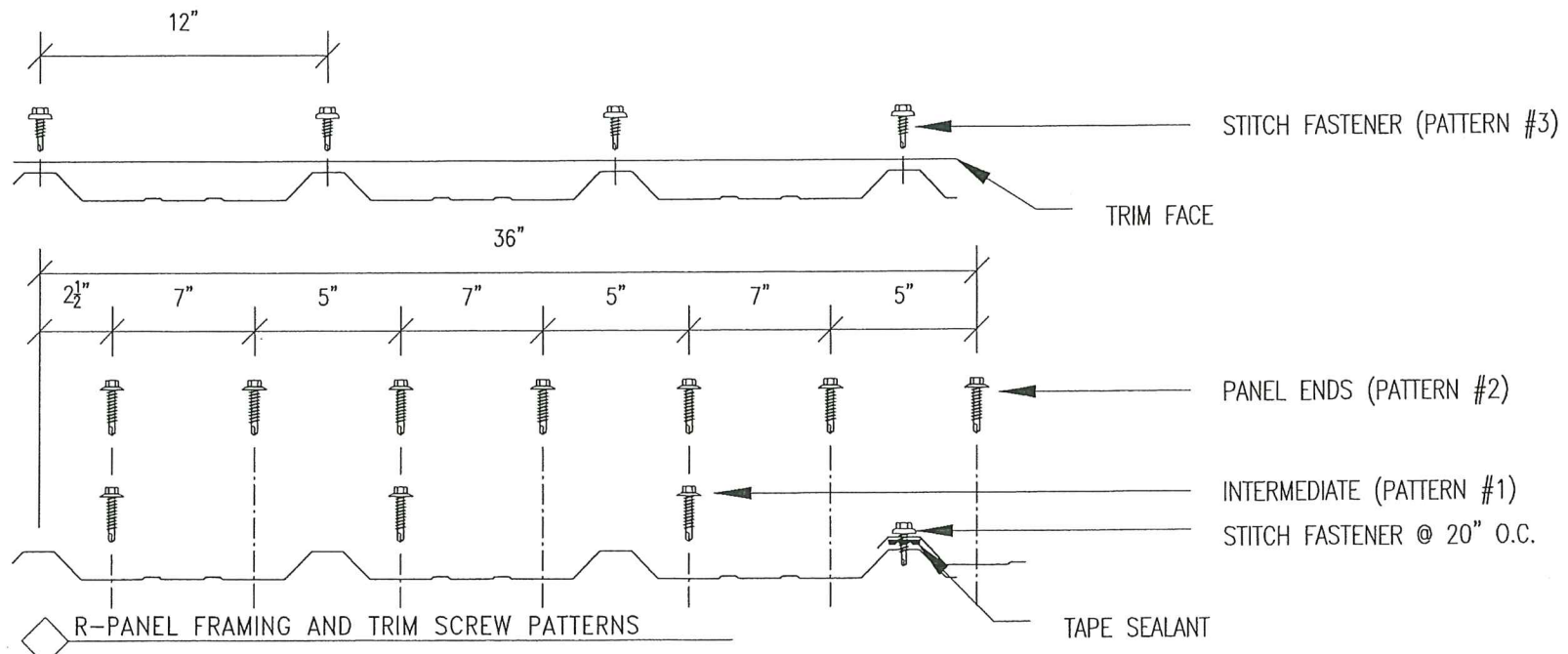

PRODUCT RENEWED as complying with the Florida Building Code  
 Acceptance No. 24-0221.01  
 Expiration Date 03/18/2029  
 By *Hely A. Malin*  
 Miami Dade Product Control

PRODUCT REVISED as complying with the Florida Building Code  
 Acceptance No. 22-1024.03  
 Expiration Date 03/18/2024  
 By *Hely A. Malin*  
 Miami Dade Product Control

MANUFACTURING ENGINEER		JOHNATHAN GREEN, P.E.	
FLORIDA REGISTRATION NO.		88223	
PROJECT		DADE COUNTY TESTING	
SHEET TITLE		TREMLOCK R STEEL WALL PANEL 24ga. DETAILS	
DATE		08-16-22	
SCALE		N.T.S.	
LOCATION		DADE COUNTY, FLORIDA	
PROJECT NUMBER		13-0716.11	
SHEET NUMBER		E2 of 5	

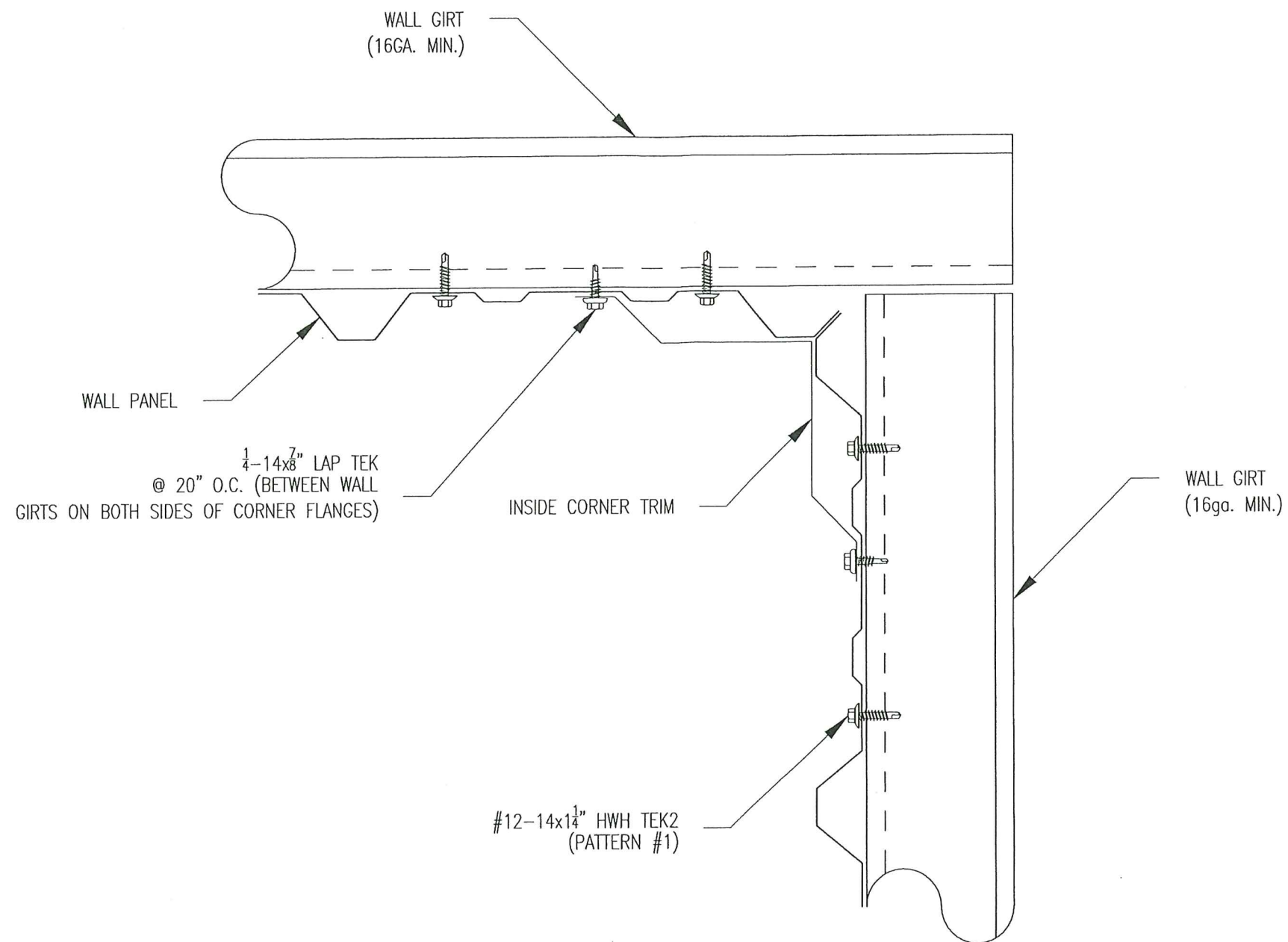

THIS ITEM HAS BEEN DIGITALLY SIGNED AND SEALED BY JOHNATHAN GREEN ON THE DATE ADJACENT TO THE SEAL.  
 PRINTED COPIES OF THIS DOCUMENT ARE NOT CONSIDERED SIGNED AND SEALED AND THE SIGNATURE MUST BE VERIFIED ON ANY ELECTRONIC COPIES.

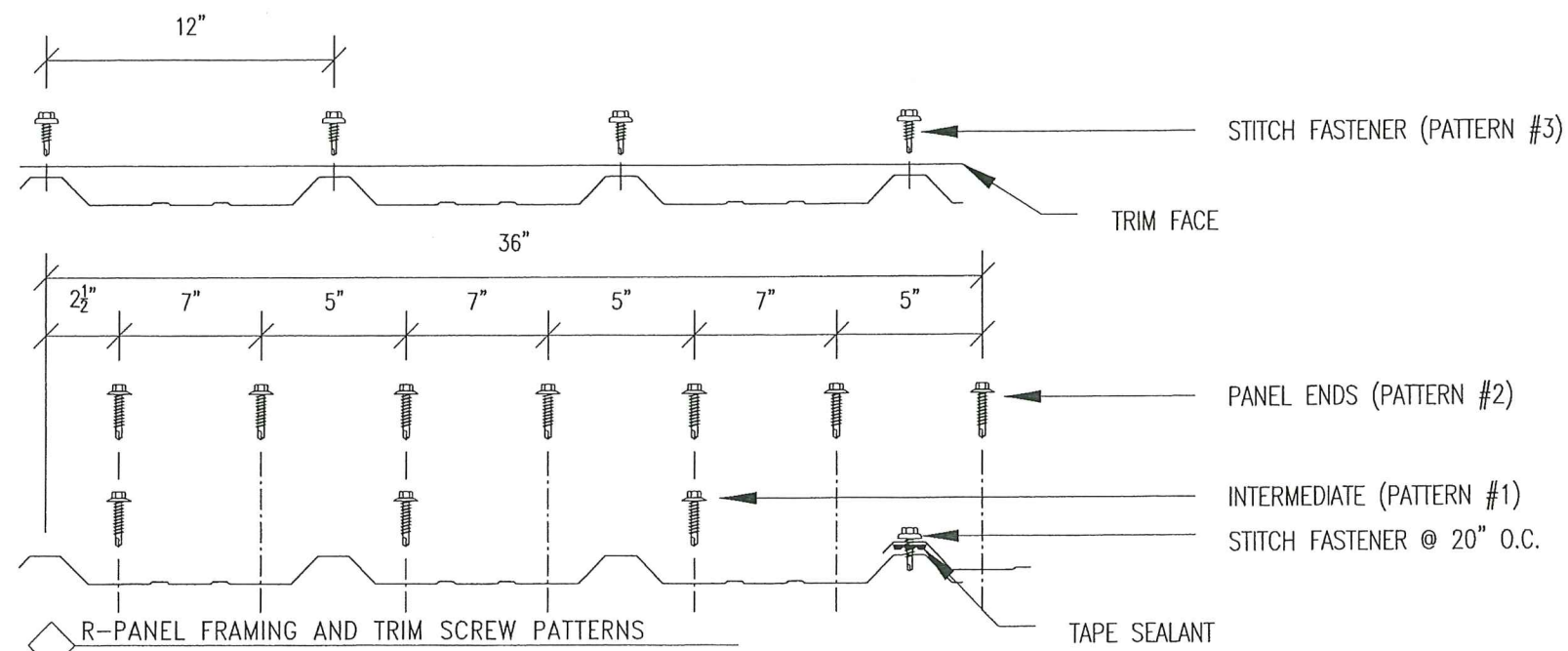
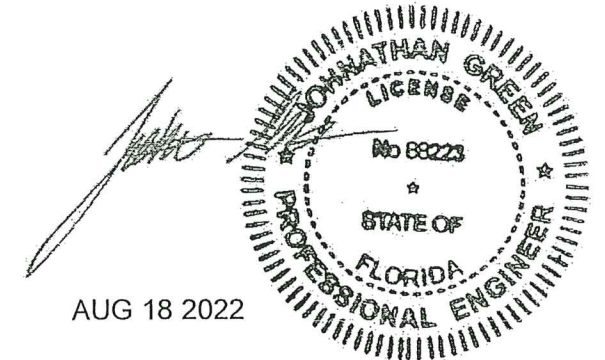

1 INSIDE CORNER

**PRODUCT RENEWED**  
 as complying with the Florida Building Code  
 Acceptance No 24-0221.01  
 Expiration Date 03/18/2029  
 By Helga A. Nelson  
 Miami Dade Product Control

**PRODUCT REVISED**  
 as complying with the Florida Building Code  
 Acceptance No 22-1024.03  
 Expiration Date 03/18/2024  
 By Helga A. Nelson  
 Miami Dade Product Control

MANUFACTURING ENGINEER		JOHNATHAN GREEN, P.E.	
FLORIDA REGISTRATION NO.		88223	
REL.	BY	DESCRIPTION	DATE
	JC	FOR APPROVAL	08-17-22
PROJECT		DADE COUNTY TESTING	
SHEET TITLE		TREMLOCK R STEEL WALL PANEL 24ga. DETAILS	
DRAWN BY:		DATE: 08-16-22	
CHECKED BY:		SCALE: N.T.S.	
LOCATION		DADE COUNTY, FLORIDA	
PROJECT NUMBER		13-0716.11 E3 of 5	

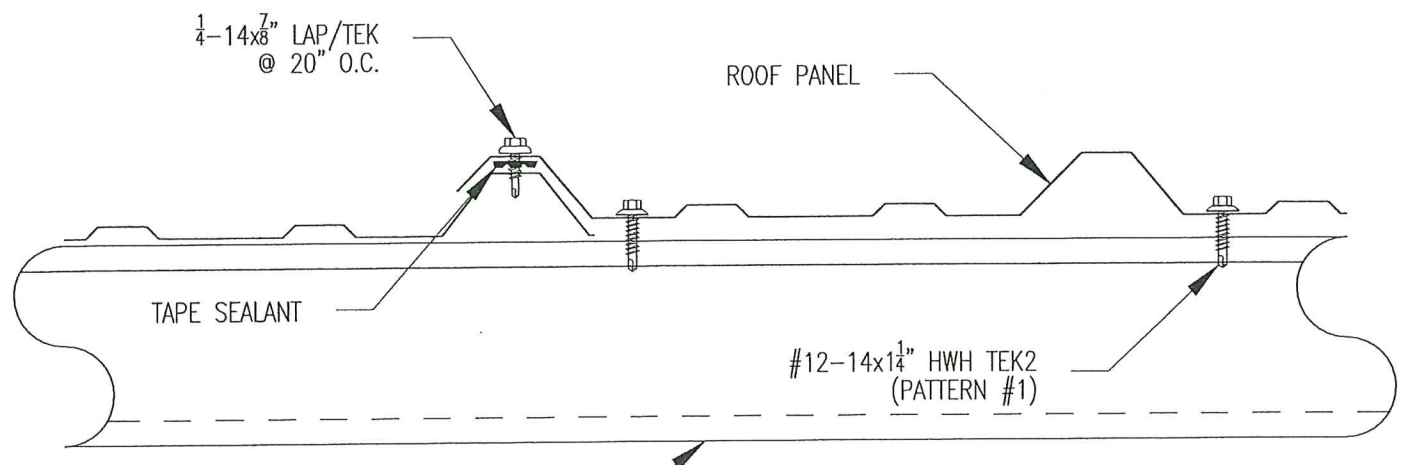
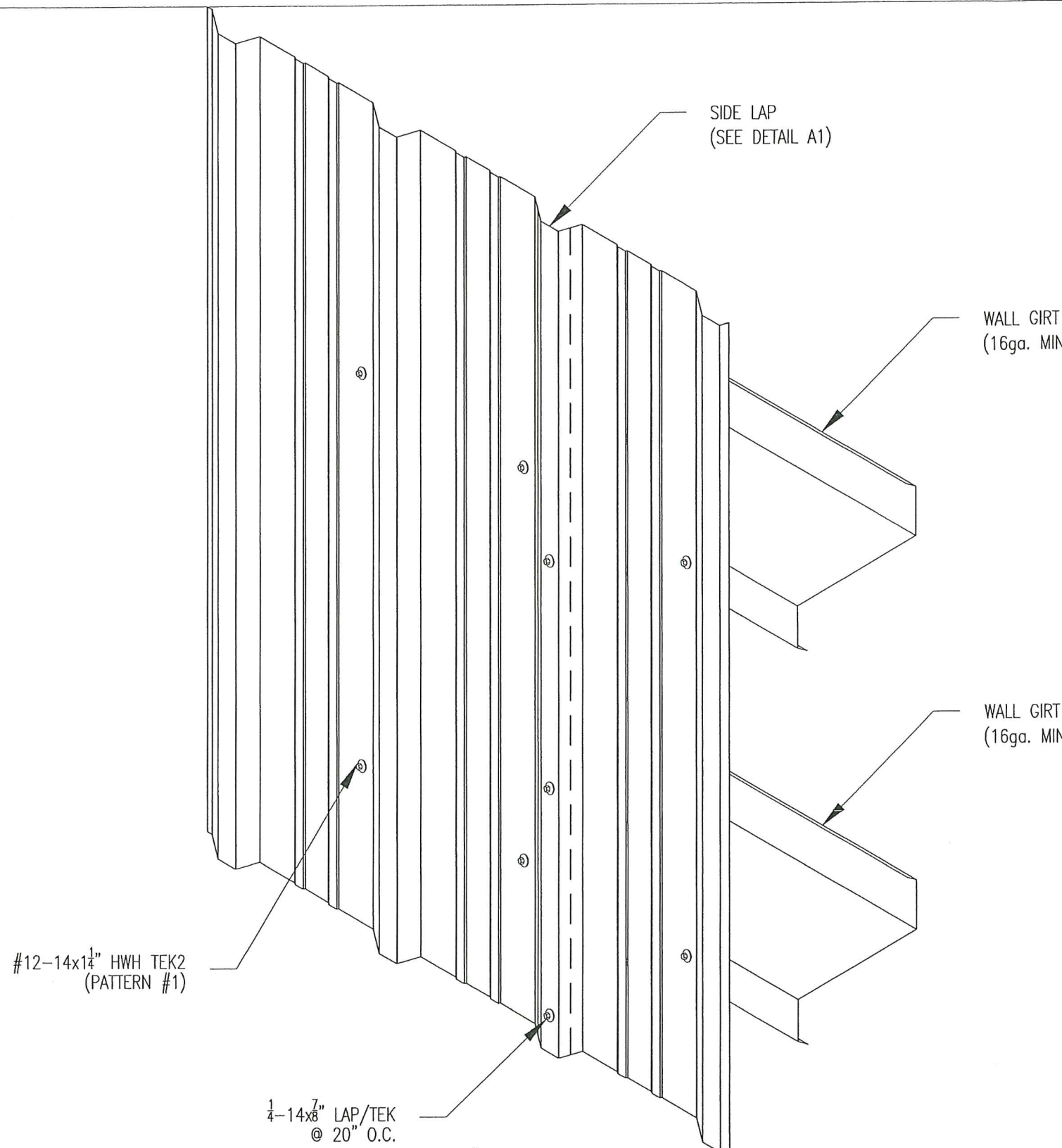

◇ DETAIL A1

THIS ITEM HAS BEEN DIGITALLY SIGNED AND SEALED BY JOHNATHAN GREEN ON THE DATE ADJACENT TO THE SEAL.  
 PRINTED COPIES OF THIS DOCUMENT ARE NOT CONSIDERED SIGNED AND SEALED AND THE SIGNATURE MUST BE VERIFIED ON ANY ELECTRONIC COPIES.

*Jonathan Green*  
 AUG 18 2022

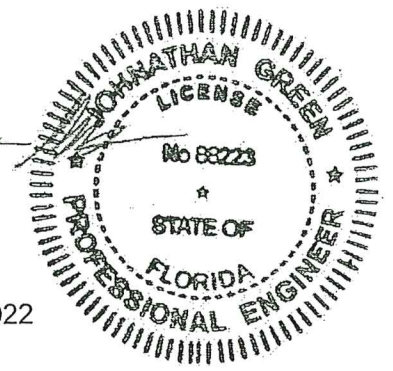

◇ 1 PANEL LAP

<b>PRODUCT RENEWED</b> as complying with the Florida Building Code Acceptance No. <u>24-0221.01</u> Expiration Date <u>03/18/2029</u> By <i>Healy A. Mohr</i> Miami Data Product Control	<b>PRODUCT REVISED</b> as complying with the Florida Building Code Acceptance No. <u>22-1024.03</u> Expiration Date <u>03/18/2024</u> By <i>Healy A. Mohr</i> Miami Data Product Control
---	---

MANUFACTURING ENGINEER	JOHNATHAN GREEN, P.E.
FLORIDA REGISTRATION NO.	88223

REL	BY	DESCRIPTION	DATE
	JG	FOR APPROVAL	08-17-22

PROJECT	DADE COUNTY TESTING	DATE	08-16-22
SHEET TITLE	TREMLOCK R STEEL WALL PANEL 24ga. DETAILS	CHECKED BY	N.T.S.
LOCATION		PROJECT NUMBER	

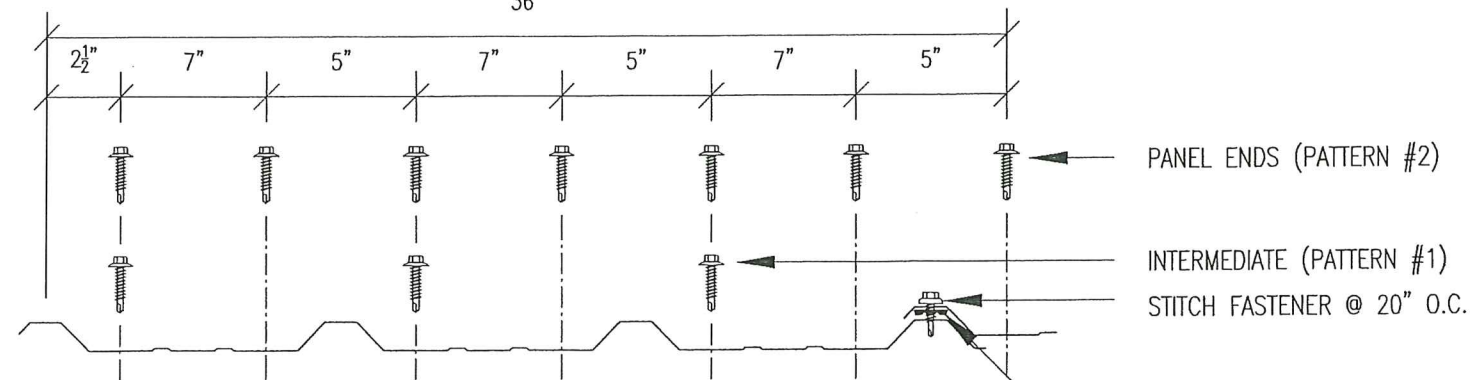



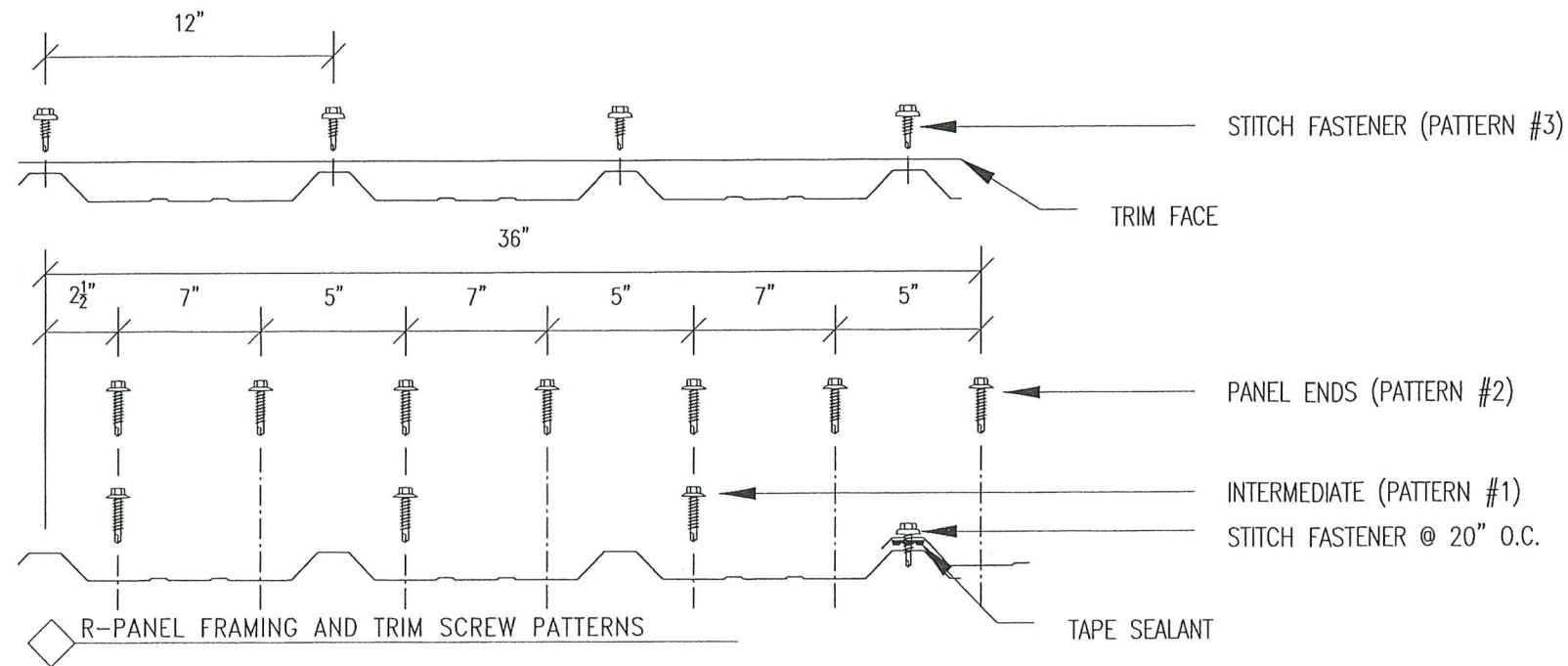

NOTES:

- THE MAXIMUM PRESSURE SHALL BE CALCULATED USING THE FOLLOWING ALLOWANCES.
  - MAXIMUM ALLOWABLE BENDING MOMENT OF THE PANEL AT SUPPORTS = 156.25 FT. LB.
  - MAXIMUM ALLOWABLE BENDING MOMENT OF THE PANEL BETWEEN SUPPORTS = 87.89 FT. LB.
  - MAXIMUM ALLOWABLE DEFLECTION OF ROOF PANEL = L/240
  - MAXIMUM ALLOWABLE REACTION = 93.75 LBS EXT.  
= 156.25 LBS. INT.
  - $EI = 1.2213 \times 10^6 \text{ LB-IN}^2$
- THE MAXIMUM ALLOWABLE SPANS & PRESSURES ARE AS FOLLOWS:
 

SPAN	PRESSURE
5'-0"	50.0 PSF

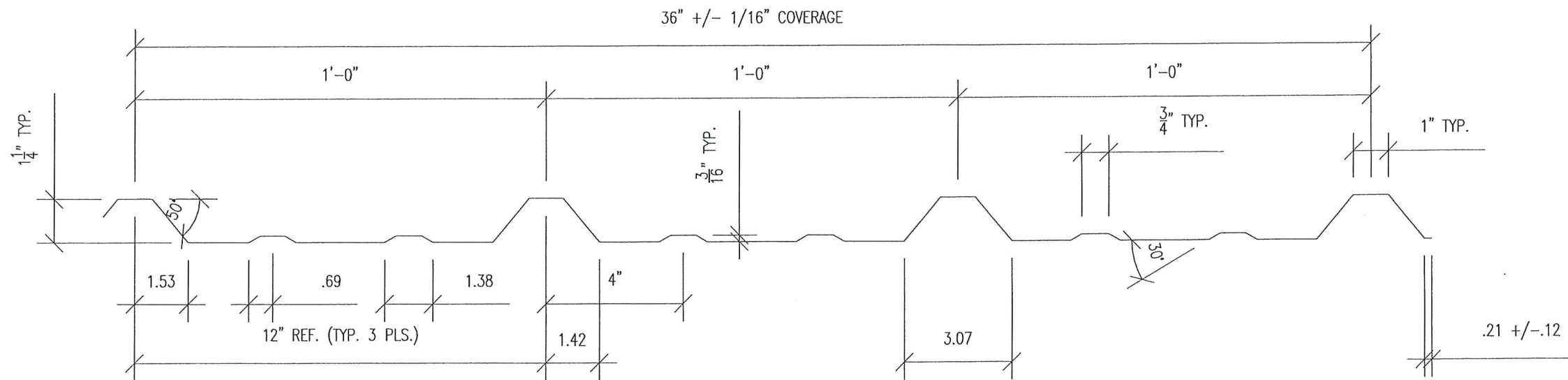

TREMLOCK R STEEL WALL PANEL PROFILE

**STITCH FASTENER:**  
1/4-14x7/8" LAP/TEK ZAC  
BY: SFS INTEC  
\*\* SEE NOTE BELOW

SIKALASTOMER 511 TUBE SEALANT  
BY: SIKA

**FRAMING FASTENER:**  
#12-14x1 1/4" TEK2 ZAC  
BY: SFS INTEC  
\*\* SEE NOTE BELOW  
\*\* NOTE  
ZAC IS A ZINC-ALUMINUM CAP  
WITH A 5/8" DIA. NEPRENE  
SEALING WASHER

SIKAFLEX 201 URETHANE TUBE SEALANT  
BY: SIKA  
  
 1/8"x1" BUTYL ROLL TAPE SEALANT  
BY: SCHNEE-MOREHEAD

THIS ITEM HAS BEEN DIGITALLY SIGNED AND SEALED BY JOHNATHAN GREEN ON THE DATE ADJACENT TO THE SEAL. PRINTED COPIES OF THIS DOCUMENT ARE NOT CONSIDERED SIGNED AND SEALED AND THE SIGNATURE MUST BE VERIFIED ON ANY ELECTRONIC COPIES.

AUG 18 2022

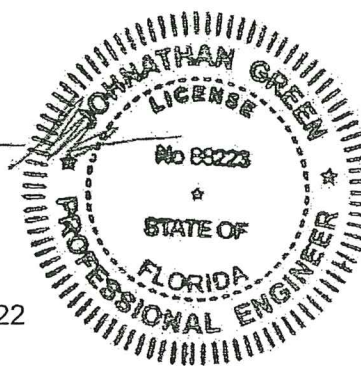

PRODUCT RENEWED  
as complying with the Florida  
Building Code  
Acceptance No. 24-0221.01  
Expiration Date 03/18/2029  
By *Helga A. Malin*  
Miami Dade Product Control

PRODUCT REVISED  
as complying with the Florida  
Building Code  
Acceptance No. 22-1024.03  
Expiration Date 03/18/2024  
By *Helga A. Malin*  
Miami Dade Product Control

MANUFACTURING ENGINEER		JOHNATHAN GREEN, P.E.									
FLORIDA REGISTRATION NO.		88223									
<table border="1"> <thead> <tr> <th>REL.</th> <th>BY</th> <th>DESCRIPTION</th> <th>DATE</th> </tr> </thead> <tbody> <tr> <td></td> <td>JO</td> <td>FOR APPROVAL</td> <td>08-17-22</td> </tr> </tbody> </table>				REL.	BY	DESCRIPTION	DATE		JO	FOR APPROVAL	08-17-22
REL.	BY	DESCRIPTION	DATE								
	JO	FOR APPROVAL	08-17-22								
PROJECT		DADE COUNTY TESTING									
SHEET TITLE		TREMLOCK R STEEL WALL PANEL 24ga. DETAILS									
DRAWN BY		DATE: 08-16-22									
CHECKED BY		SCALE: N.T.S.									
LOCATION		DADE COUNTY, FLORIDA									
PROJECT NUMBER		DRAWING NUMBER: 13-0716.11 SHEET NUMBER: F5 of 5									

PANEL PROPERTIES						
ASTM	PANEL GAUGE	PANEL THICKNESS	YIELD STRENGTH	TENSILE STRENGTH	STEEL COATING	PAINT COATINGS
A792	24	.023 (MIN.)	50 KSI (MIN.)	65 KSI (MIN.)	AZ 55 (BARE)	KYNAR 500