



DEPARTMENT OF REGULATORY AND ECONOMIC RESOURCES (RER)
BOARD AND CODE ADMINISTRATION DIVISION

NOTICE OF ACCEPTANCE (NOA)

MIAMI-DADE COUNTY
PRODUCT CONTROL SECTION
11805 SW 26 Street, Room 208
Miami, Florida 33175-2474
T (786) 315-2590 F (786) 315-2599
www.miamidade.gov/economy

Quickscrews Int'l Corp.
5830 Las Positas Rd.
Livermore, CA 94551

SCOPE:

This NOA is being issued under the applicable rules and regulations governing the use of construction materials. The documentation submitted has been reviewed and accepted by Miami-Dade County RER-Product Control Section to be used in Miami-Dade County and other areas where allowed by the Authority Having Jurisdiction (AHJ).

This NOA shall not be valid after the expiration date stated below. The Miami-Dade County Product Control Section (In Miami-Dade County) and/ or the AHJ (in areas other than Miami-Dade County) reserve the right to have this product or material tested for quality assurance purposes. If this product or material fails to perform in the accepted manner, the manufacturer will incur the expense of such testing and the AHJ may immediately revoke, modify, or suspend the use of such product or material within their jurisdiction. RER reserves the right to revoke this acceptance if it is determined by Miami-Dade County Product Control Section that this product or material fails to meet the requirements of the applicable building code.

This product is approved as described herein and has been designed to comply with the Florida Building Code, including the High Velocity Hurricane Zone.

DESCRIPTION: Quick Bolt QB2 Stainless Steel L-Foot and 3” Microflashing Solar Mount

APPROVAL DOCUMENT: Drawing No. **QB2HVHZ**, titled “QB2 Kit with SS L-Foot and 3” Microflashing”, sheets 1 through 2 of 2, prepared by QuikBolt a div of Quickscrews Int’l Corp., dated on 02/24/2024, signed and sealed by Scott Wolters, P.E., bearing the Miami-Dade County Product Control revision stamp with the Notice of Acceptance number and approval date by the Miami-Dade County Product Control Section.

MISSILE IMPACT RATING: None

LABELING: Each box shall bear a permanent label with the manufacturer's name or logo, city, state and following statement: "Miami-Dade County Product Control Approved or MDCPCA", unless otherwise noted herein.

RENEWAL of this NOA shall be considered after a renewal application has been filed and there has been no change in the applicable building code negatively affecting the performance of this product.

TERMINATION of this NOA will occur after the expiration date or if there has been a revision or change in the materials, use, and/or manufacture of the product or process. Misuse of this NOA as an endorsement of any product, for sales, advertising or any other purposes shall automatically terminate this NOA. Failure to comply with any section of this NOA shall be cause for termination and removal of NOA.

ADVERTISEMENT: The NOA number preceded by the words Miami-Dade County, Florida, and followed by the expiration date may be displayed in advertising literature. If any portion of the NOA is displayed, then it shall be done in its entirety.

INSPECTION: A copy of this entire NOA shall be provided to the user by the manufacturer or its distributors and shall be available for inspection at the job site at the request of the Building Official.

This NOA revises NOA # **22-0214.03** and consists of this page 1, evidence page E-1, as well as approval document mentioned above.

The submitted documentation was reviewed by **Carlos M. Utrera, P.E.**



04/09/24

NOA No: 24-0306.05
Expiration Date: June 23, 2027
Approval Date: April 18, 2024
Page 1

NOTICE OF ACCEPTANCE: EVIDENCE SUBMITTED

1. Evidence submitted under NOA # 22-0214.03 and new

A. DRAWINGS

1. Drawing No. **QB2HVHZ**, titled “QB2 Kit with SS L-Foot and 3” Microflashing”, sheets 1 through 2 of 2, prepared by QuikBolt a div of Quickscrews Int’l Corp., dated on 02/24/2024, signed and sealed by Scott Wolters, P.E.

B. TESTS “Submitted under NOA # 22-0214.03”

1. Test report on Uplift and Shear Allowable Loads of the 4” SS QB2 Kit w/ 3” Microflashing Solar Mount per ASTM D7147-11, prepared by Intertek, Test Report No. **K8370.01-301-18 R1**, dated 06/04/2020, with revision 1 dated 05/10/2022, signed and sealed by Tyler Westerling, P.E.
2. Test report on Wind Driven Rain Resistance of the 4” SS QB2 Kit w/ 3” Microflashing Solar Mount per TAS 100(A)-95, prepared by Intertek, Test Report No. **K8370.02-301-18 R0**, dated 06/04/2020, signed and sealed by Tyler Westerling, P.E.

C. CALCULATIONS “Submitted under NOA # 22-0214.03”

1. Anchor calculations prepared by Scott Wolters, dated 01/28/2022, signed and sealed by Scott Wolters, P.E.

D. MATERIAL CERTIFICATIONS

1. None.

E. QUALITY ASSURANCE

1. Miami-Dade Department of Regulatory and Economic Resources (RER).

F. STATEMENTS

1. Statement letter of code conformance to the 8th edition (2023) of the FBC, issued by Wolters Engineering, dated 02/24/2024, signed and sealed by Scott Wolters, P.E.

“Submitted under NOA # 22-0214.03”

2. Drawing statement of code conformance to the 7th edition (2020) of the FBC issued by QuikBolt a div of Quickscrews Int’l Corp., dated 01/28/2022, signed and sealed by Scott Wolters, P.E. on 05/26/2022
3. Statement letter of no financial interest issued by Wolters Engineering, dated 01/31/2022, signed and sealed by Scott Wolters, P.E.



Carlos M. Utrera, P.E.
Product Control Examiner
NOA No: 24-0306.05
Expiration Date: June 23, 2027
Approval Date: April 18, 2024

QB2 ANCHOR BRACKET SYSTEM WITH 3" MICROFLASHING.

GENERAL NOTES:

1. THIS SYSTEM HAS BEEN DESIGNED AND TESTED TO MEET ALL OF THE REQUIREMENTS OF THE 8TH EDITION (2023) FLORIDA BUILDING CODE, INCLUDING THE HVHZ PROVISIONS.
2. THIS SYSTEM HAS BEEN TESTED PER TAS 100(A) AND ASTM D7147.
3. THE DESIGN OF THE SUBSTRATE IS THE RESPONSIBILITY OF THE ENGINEER OF RECORD OR OTHER SPECIALTY ENGINEER, AND IS NOT A PART OF THIS APPROVAL. THE SUBSTRATE MUST SAFELY TRANSMIT THE LOADS APPLIED TO THIS SYSTEM TO THE BUILDING STRUCTURE.
4. FIRE RATINGS OR FIRE RESISTANCE IS NOT A PART OF THIS REVIEW.
5. ALL ANCHORS SECURING THE SYSTEM TO PRESSURE TREATED WOOD SHALL BE CAPABLE OF RESISTING CORROSION CAUSED BY THE CHEMICALS IN THE WOOD.
6. MATERIALS INCLUDING BUT NOT LIMITED TO STEEL/METAL SCREWS THAT COME INTO CONTACT WITH OTHER DISSIMILAR MATERIALS SHALL BE PROTECTED PER FBC REQUIREMENTS.
7. NO INCREASE IN ALLOWABLE STRESS HAS BEEN USED IN THE DESIGN OF THIS PRODUCT. Cd=1.6 WAS USED FOR WOOD SCREWS ONLY.
8. VALUES SHOWN FOR THE ALLOWABLE LOADS ARE BASED ON THE QB2 MOUNTING SCREW INSTALLED WITH 3" MIN EMBEDMENT, 5/8" MIN EDGE DISTANCE, AND 2 1/2" MIN. END DISTANCE.

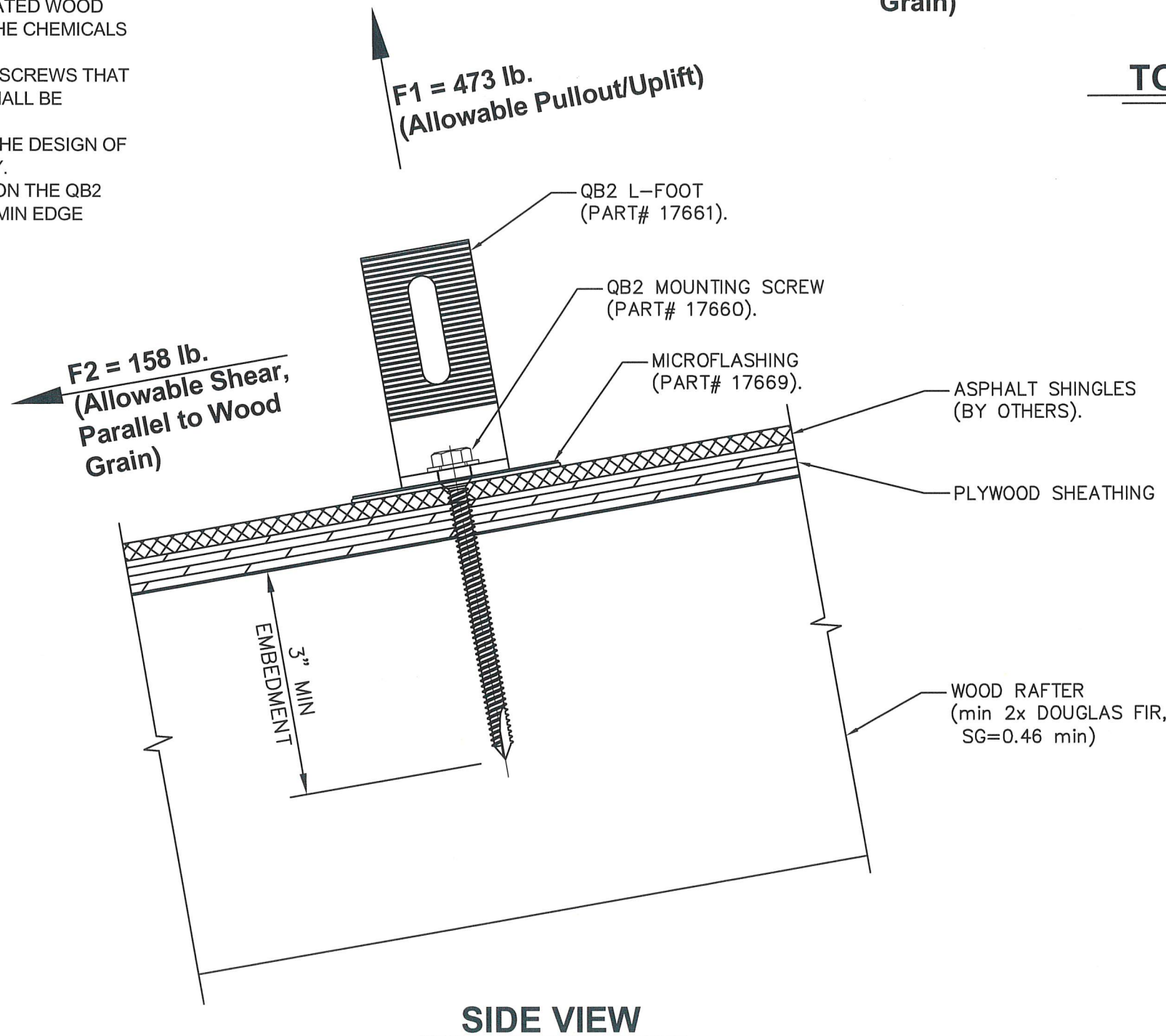

F3 = 19.3 lb.
(Allowable Shear,
Perpendicular to
Wood Grain)

F2 = 158 lb.
(Allowable Shear,
Parallel to Wood
Grain)

F1 = 473 lb.
(Allowable Pullout/Uplift)

TOP VIEW

SIDE VIEW

PRODUCT REVISED
as complying with the Florida
Building Code
NOA-No. 24-0306.05
Expiration Date 06/23/2027
By *[Signature]*
Miami-Dade Product Control

REV.#	DATE	DESCRIPTION
1	2/24/24	2023 CODE UPDATE
2	1/28/22	1ST SUBMITTAL
		PRINTS ISSUED FOR

QuickBOLT
World's First UL Certified Microflashing®
PH: (844) 671-6045
WWW.QUICKBOLT.COM
5830 LAS POSITAS RD
LIVERMORE, CA 94551

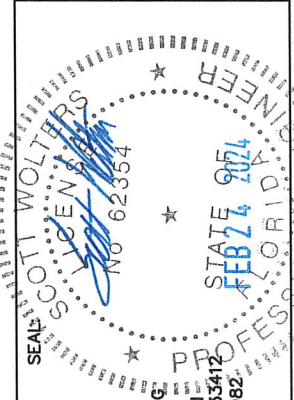

SCOTT WOLTERS
FL PE# 62354
WOLTERS ENGINEERING
(COA# 27194)
15211 97TH ROAD N
WEST PALM BEACH, FL 33412
PH/FAX: (561) 225-1982

PRODUCT:
QB2 KIT WITH
SS L-FOOT AND
3" MICROFLASHING
DWG: QB2HVHZ
SHEET: 1/2

**QB2 ANCHOR BRACKET SYSTEM
WITH 3" MICROFLASHING.**

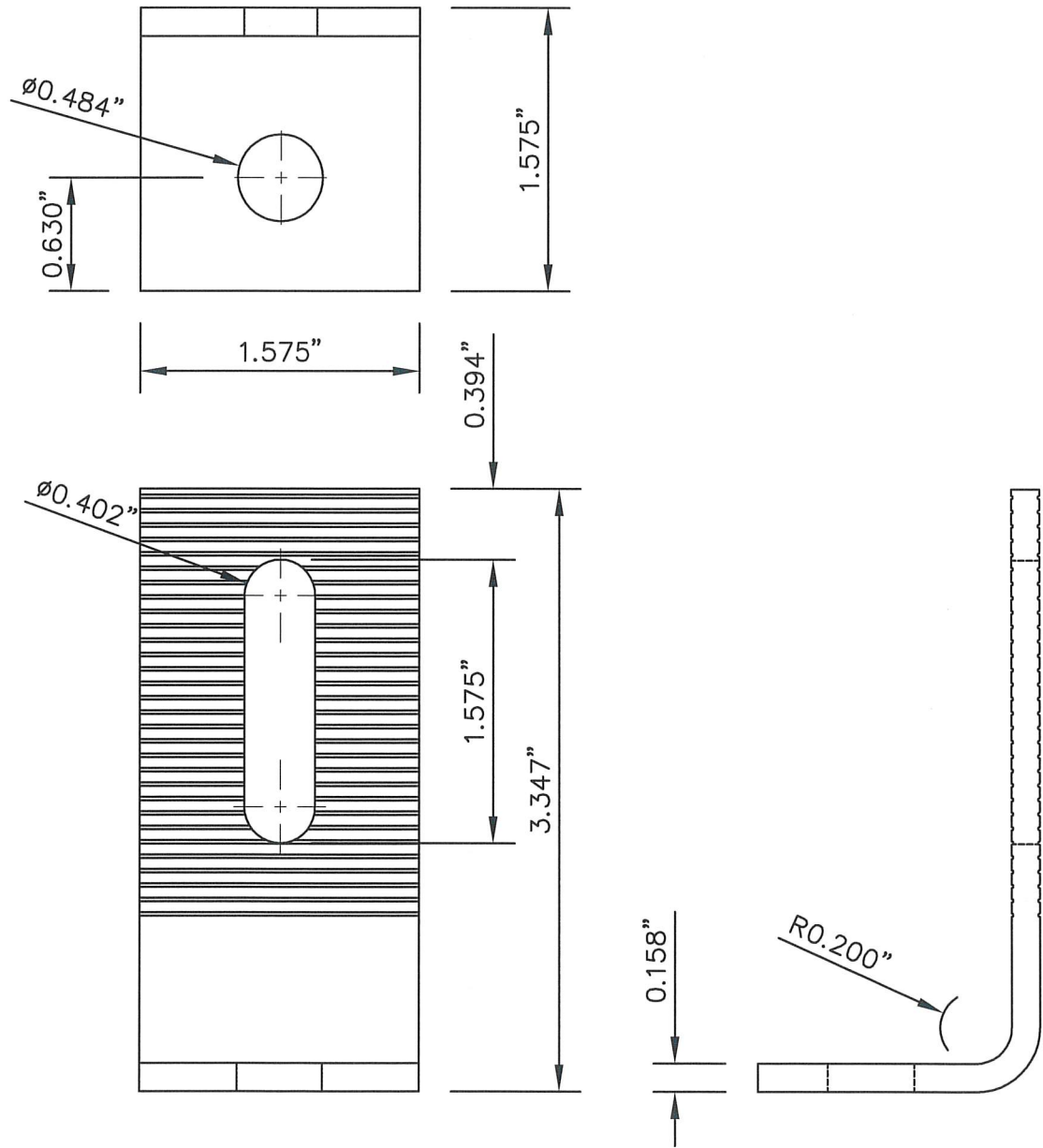

PART# 17661 - QB2 L-FOOT BRACKET. (304 SERIES STAINLESS STEEL).

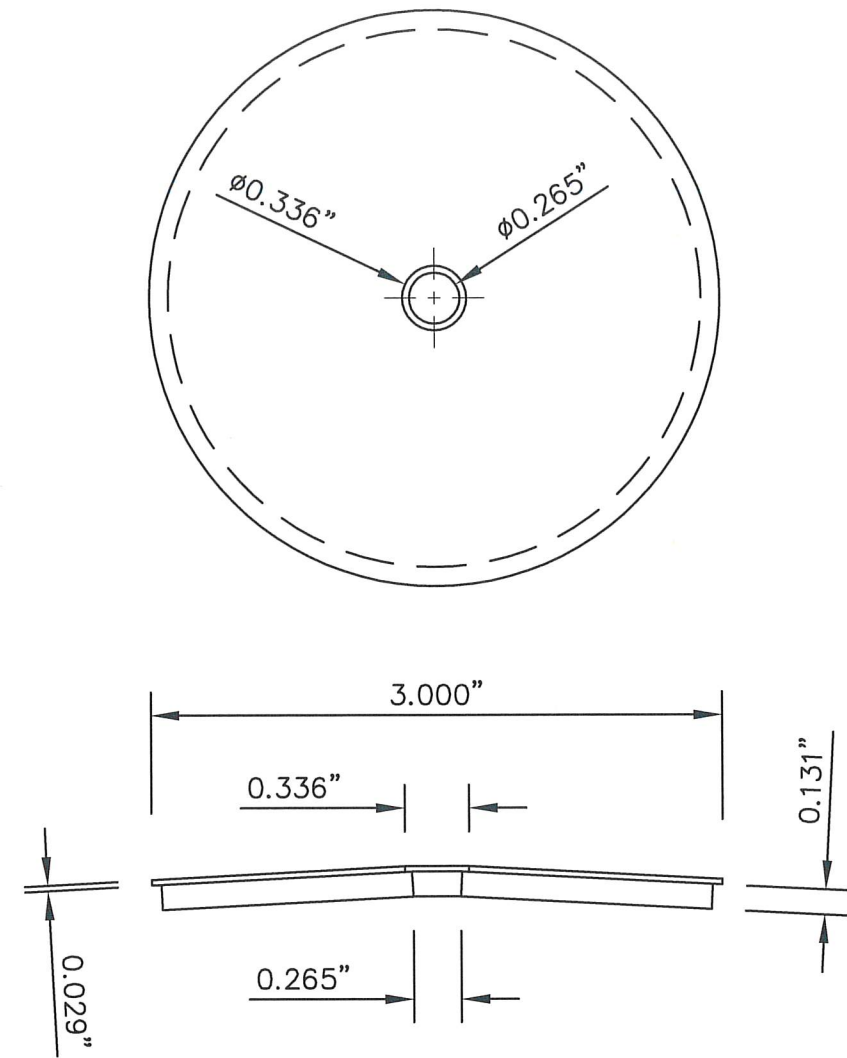

PART# 17669 - 3" MICROFLASHING.
3"Ø x 0.029" STAINLESS STEEL (304 SERIES) WASHER, WITH
2 7/8"Ø x 0.131" EPDM GASKET.

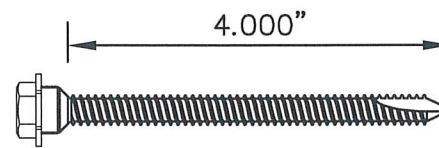

PART# 17660 - 5/16"x4" STAINLESS STEEL (304 SERIES) HEX FLANGE DUAL DRIVE WOOD SCREW.

PRODUCT REVISED
as complying with the Florida Building Code
NOA-No. 24-0306.05
Expiration Date 06/23/2027
By *[Signature]*
Miami-Dade Product Control

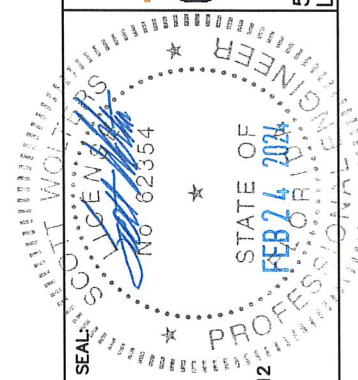

SCOTT WOLTERS
FL PE# 62354
WOLTERS ENGINEERING
(COA# 27194)
15211 97TH ROAD N
WEST PALM BEACH, FL 33412
PH/FAK:(561) 225-1982

PRODUCT:
QB2 KIT WITH
SS L-FOOT AND
3" MICROFLASHING
DWG:
QB2HVHZ
SHEET:
2/2

REV.#	ISSUED FOR	DATE
1	PRINTS ISSUED FOR	1/28/22
2	2023 CODE UPDATE	2/24/24
3	1ST SUBMITTAL	1/28/22

QuickBOLT
World's First UL Certified Microflashing®
5830 LAS POSITAS RD
LIVERMORE, CA 94551
PH: (844) 671-6045
WWW.QUICKBOLT.COM