



DEPARTMENT OF REGULATORY AND ECONOMIC RESOURCES (RER)  
BOARD AND CODE ADMINISTRATION DIVISION

**NOTICE OF ACCEPTANCE (NOA)**

MIAMI-DADE COUNTY  
PRODUCT CONTROL SECTION  
11805 SW 26 Street, Room 208  
Miami, Florida 33175-2474  
T (786) 315-2590 F (786) 315-2599  
[www.miamidade.gov/building](http://www.miamidade.gov/building)

**EPIC Metals Corp.**  
**11 Talbot Avenue**  
**Rankin, PA 15104**

**SCOPE:**

This NOA is being issued under the applicable rules and regulations governing the use of construction materials. The documentation submitted has been reviewed and accepted by Miami-Dade County RER-Product Control Section to be used in Miami Dade County and other areas where allowed by the Authority Having Jurisdiction (AHJ).

This NOA shall not be valid after the expiration date stated below. The Miami-Dade County Product Control Section (In Miami Dade County) and/or the AHJ (in areas other than Miami Dade County) reserve the right to have this product or material tested for quality assurance purposes. If this product or material fails to perform in the accepted manner, the manufacturer will incur the expense of such testing and the AHJ may immediately revoke, modify, or suspend the use of such product or material within their jurisdiction. RER reserves the right to revoke this acceptance if it is determined by Miami-Dade County Product Control Section that this product or material fails to meet the requirements of the applicable building code.

This product is approved as described herein and has been designed to comply with the Florida Building Code, including the High Velocity Hurricane Zone.

**DESCRIPTION: EPIC Architectural & Sunscreen Perforated Steel Panels - L.M.I.**

**APPROVAL DOCUMENT:** Drawing No. **23-616-Epic-LMI-ER**, titled "EPIC Metals EST4 & ESW Series" (L.M.I.) Perforated Steel Sunscreen Panel", sheets 1 through 13 of 13, dated 09/14/2023, prepared by CBuck, Inc., signed and sealed by James L. Buckner, P.E., bearing the Miami-Dade County Product Control renewal stamp with the Notice of Acceptance number and expiration date by the Miami-Dade County Product Control Section.

**MISSILE IMPACT RATING: Large and Small Missile Impact Resistant**

**LABELING:** Each panel shall bear a permanent label with the manufacturer's name or logo, city, state, model/series, and following statement: "Miami-Dade County Product Control Approved", unless otherwise noted herein.

**RENEWAL** of this NOA shall be considered after a renewal application has been filed and there has been no change in the applicable building code negatively affecting the performance of this product.

**TERMINATION** of this NOA will occur after the expiration date or if there has been a revision or change in the materials, use, and/or manufacture of the product or process. Misuse of this NOA as an endorsement of any product, for sales, advertising or any other purposes shall automatically terminate this NOA. Failure to comply with any section of this NOA shall be cause for termination and removal of NOA.

**ADVERTISEMENT:** The NOA number preceded by the words Miami-Dade County, Florida, and followed by the expiration date may be displayed in advertising literature. If any portion of the NOA is displayed, then it shall be done in its entirety.

**INSPECTION:** A copy of this entire NOA shall be provided to the user by the manufacturer or its distributors and shall be available for inspection at the job site at the request of the Building Official. This NOA **renews NOA No. 23-0926.10** and consists of page 1 and evidence pages E-1, E-2 and E-3, as well as the approval document mentioned above.

The submitted documentation was reviewed by **Carlos M. Utrera, P.E.**



04/09/24

NOA No: 24-0311.05  
Expiration Date: May 23, 2029  
Approval Date: April 18, 2024

**NOTICE OF ACCEPTANCE: EVIDENCE PAGE**

**1. EVIDENCE SUBMITTED UNDER NOA # 17-1221.25**

**A. DRAWINGS**

1. Drawing No. **16-148-ER-ES.1**, titled “EPIC Metals ESW & EST Series Perforated Steel Sunscreen Panel”, sheets 1 through 13 of 13, dated 06/04/19, prepared by CBuck, Inc., signed and sealed by James L. Buckner, P.E.

**B. TESTS**

	<b><u>Test Report No.</u></b>	<b><u>Test Standard</u></b>	<b><u>Date</u></b>	<b><u>Signature</u></b>
1.	T226-17	TAS 202-94	07/31/17	Daniel G. Farabaugh, P.E.
2.	T263-18	TAS 203-94	09/21/18	Daniel G. Farabaugh, P.E.
3.	T225-18	TAS 202-94	06/22/18	Daniel G. Farabaugh, P.E.
4.	T220-18 Rev	TAS 202-94	06/18/18	Daniel G. Farabaugh, P.E.
5.	T224-17	TAS 202-94	07/31/17	Daniel G. Farabaugh, P.E.
6.	T264-18	TAS 203-94	09/18/18	Daniel G. Farabaugh, P.E.
7.	T224-18	TAS 202-94	06/22/18	Daniel G. Farabaugh, P.E.
8.	T225-17	TAS 202-94	07/31/17	Daniel G. Farabaugh, P.E.
9.	T265-18	TAS 203-94	09/18/18	Daniel G. Farabaugh, P.E.
10.	T191-17	AISI S905-13	07/17/17	Daniel G. Farabaugh, P.E.

**C. CALCULATION**

1. Engineering analysis prepared by CBuck, Inc., dated 03/28/19, signed and sealed by James L. Buckner, P.E.

**D. QUALITY ASSURANCE**

1. Miami-Dade Department of Regulatory and Economic Resources (RER)

**E. MATERIAL CERTIFICATION**

1. None.

**F. STATEMENTS**

1. Statement letter of code conformance to the **FBC 6<sup>th</sup> Edition (2017)** and of no financial interest, dated 12/14/17, issued by CBuck, Inc., signed and sealed by James L. Buckner, P.E.



---

**Carlos M. Utrera, P.E.**  
**Product Control Examiner**  
**NOA No: 24-0311.05**  
**Expiration Date: May 23, 2029**  
**Approval Date: April 18, 2024**

**NOTICE OF ACCEPTANCE: EVIDENCE PAGE**

**2. EVIDENCE SUBMITTED UNDER NOA # 21-0830.03**

**A. DRAWINGS**

1. Drawing No. **16-148-ER-ES.1**, titled “EPIC Metals ESW & EST Series Perforated Steel Sunscreen Panel”, sheets 1 through 13 of 13, dated 06/04/19, with revision 20-431-ER-7<sup>th</sup> dated 08/04/21, prepared by CBuck, Inc., signed and sealed by James L. Buckner, P.E.

**B. TESTS**

1. None

**C. CALCULATIONS**

1. None

**D. QUALITY ASSURANCE**

1. Miami-Dade Department of Regulatory and Economic Resources (RER)

**E. MATERIAL CERTIFICATIONS**

1. None.

**F. STATEMENTS**

1. Statement letter of code conformance to the **FBC 7<sup>th</sup> Edition (2020)** dated 03/11/21, issued by CBuck, Inc., signed and sealed by James L. Buckner, P.E.

**G. OTHERS**

1. Notice of Acceptance No. **17-1221.25**, issued to EPIC Metals Corp. for their EPIC EST 4 and Series ESW Perforated Steel Sunscreen Panels, approved on 05/23/19 and expiring on 05/23/24.



---

**Carlos M. Utrera, P.E.**  
**Product Control Examiner**  
**NOA No: 24-0311.05**  
**Expiration Date: May 23, 2029**  
**Approval Date: April 18, 2024**

**NOTICE OF ACCEPTANCE: EVIDENCE PAGE**

**3. EVIDENCE SUBMITTED UNDER NOAs # 23-0314.10 AND # 23-0926.10**

**A. DRAWINGS**

1. Drawing No. **23-616-Epic-LMI-ER**, titled “EPIC Metals EST4 & ESW Series” (L.M.I.) Perforated Steel Sunscreen Panel”, sheets 1 through 13 of 13, dated 09/14/2023, prepared by CBuck, Inc., signed and sealed by James L. Buckner, P.E.

**B. TESTS**

1. Test reports on 1) Large Missile Impact Test per FBC, TAS 201-94  
2) Cyclic Wind Pressure Loading per FBC, TAS 203-94  
along with marked-up drawings of EST4 Sunscreen Deck Panels, prepared by Farabaugh Engineering and Testing, Inc., Test Report No. **T345-22(1)**, dated 01/05/2023, signed and sealed by Daniel G. Farabaugh, P.E.
2. Test reports on 1) Large Missile Impact Test per FBC, TAS 201-94  
2) Cyclic Wind Pressure Loading per FBC, TAS 203-94  
along with marked-up drawings of ESW750 Sunscreen Deck Panels, prepared by Farabaugh Engineering and Testing, Inc., Test Report No. **T346-22(1)**, dated 01/05/2023, signed and sealed by Daniel G. Farabaugh, P.E.

**C. CALCULATIONS**

1. Engineering analysis prepared by CBuck, Inc., dated 03/10/2023, signed and sealed by James L. Buckner, P.E.

**D. QUALITY ASSURANCE**

1. Miami-Dade Department of Regulatory and Economic Resources (RER).

**E. MATERIAL CERTIFICATIONS**

1. None.

**F. STATEMENTS**

1. Drawing statements of code conformance to the 8<sup>th</sup> edition (2023) of the FBC, issued by CBuck, Inc., dated 09/14/2023, signed and sealed by James L. Buckner, P.E.
2. Statement of code conformance to the 7<sup>th</sup> edition (2020) of the FBC and of no financial interest, issued by CBuck, Inc., dated 03/10/2023, signed and sealed by James L. Buckner, P.E.



---

**Carlos M. Utrera, P.E.**  
**Product Control Examiner**  
**NOA No: 24-0311.05**  
**Expiration Date: May 23, 2029**  
**Approval Date: April 18, 2024**

# Engineering Report & Drawings

Of

## Epic Sunscreen Systems

EST 4

ESW 450

ESW 600

ESW 750

### Perforated Sunscreen Panel System

For

### Miami-Dade Notice of Acceptance (N.O.A.)

Category: Panels

Sub - Category: Sun Shades

Product Type: Perforated Sunscreen Panel System

Material: Steel

Prepared by:

James L. Buckner, P.E.

Florida Professional Engineer # 31242

Report No.: 23-616-Epic-LMI-ER

Date: 9/14/2023

**PRODUCT RENEWED**  
as complying with the Florida  
Building Code  
NOA-No. 24-0311.05

Expiration Date 05/23/2029

By [Signature]  
Miami-Dade Product Control

**PRODUCT REVISED**  
as complying with the Florida  
Building Code  
NOA-No. 23-0926.10

Expiration Date 05/23/2024

By [Signature]  
Miami-Dade Product Control

#### Contents:

Cover Page	Page 1
Product Details	Page 2
Section Properties/ Performance (Load Tables)	Page 3
Installation/Limitations	Page 4
Reference Data	Page 5
Product Components	Page 6
Product Drawings & Details	Page 7-11

**EPIC** METALS™

MANUFACTURER:  
Epic Metals Corporation  
11 Talbot Ave  
Rankin, PA 15104  
[www.epicmetals.com](http://www.epicmetals.com)  
(412) 351-3913

EPIC METALS "EST4 & ESW SERIES" (LARGE MISSILE IMPACT RATED)  
PERFORATED STEEL SUNSCREEN PANEL ENGINEERING REPORT

DATE:	9/14/ 23
PAGE #:	1 OF 13
REPORT #:	23-616-Epic-LMI-ER
REVISES #:	22-489-Epic-LMI-ER
PM:	DG
REVISIONS:	9/14/23

**CBUCK Engineering**  
Specialty Structural Engineering  
CBUCK, Inc. COA #8064  
[www.cbuckinc.net](http://www.cbuckinc.net)  
(561) 491-9927  
1374 Community Dr  
Jupiter, FL 33458

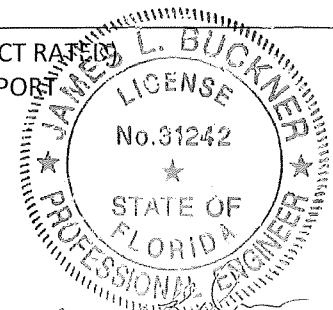

**1.0 Product:**

- 1.1 **Manufacturer:** Epic Metals Corp.
- 1.2 **Product Name:** "EST4 & ESW Series" Perforated Steel Sunscreen Panel
- 1.3 **Category:** Panels
- 1.4 **Subcategory:** Sun Shades

**PRODUCT RENEWED**  
 as complying with the Florida  
 Building Code  
 NOA-No. 24-0311.05

**2.0 Evaluation Scope:**

**2.1 Evaluation Criteria:**

- 2.1.1 Florida Building Code (FBC) 8th Edition (2023)
- 2.1.2 Code Section: High Velocity Hurricane Zone (HVHZ)
- 2.1.3 Miami-Dade Department Of Regulatory And Economic Resources, Product Control Section Checklist # 0250

**Expiration Date** 05/23/2029

By [Signature]  
**Miami-Dade Product Control**

**2.2 Properties Evaluated:**

- 2.2.1 Structural Resistance Properties
  - 2.2.1.1 Uniform Static Air Pressure per TAS 202
  - 2.2.1.2 Cyclic Wind Pressure Loading per TAS 203
  - 2.2.1.3 Large Missile Impact per TAS 201
- 2.2.2 Material Properties
  - 2.2.2.1 Tensile Strength per ASTM E8

**PRODUCT REVISED**  
 as complying with the Florida  
 Building Code  
 NOA-No. 23-0926.10

**Expiration Date** 05/23/2024

By [Signature]  
**Miami-Dade Product Control**

**2.3 Limits of Evaluation:**

This product is limited to compliance with the criteria in section 2.1 and properties in Section 2.2 of this report.

**3.0 Evaluated Uses:**

Epic Metals "EST4 & ESW Series" Perforated Steel Sunscreen Panels are evaluated for use as exterior Sunshades. They are attached to steel girts as exterior cladding.

**4.0 Assembly Description:**

**4.1 General:**

EST4, ESW450, ESW600 and ESW750 panels are made from steel conforming to ASTM A653 SS grade 40, with a minimum G90 galvanized steel with coating designation per section 12.0. As an option, the panels can be coated with an Epishield paint on all surfaces. The EST4 panels are made from 16, or 18 gage steel. The ESW450, ESW600 and ESW750 panels are made from 14, or 16 gage steel.

1. EST4: 4-inch deep panel, 24-inch width with perforations in the widest flange.
2. ESW450: 4.5-inch deep panel, 18-inch width with perforations in the widest flange and webs.
3. ESW600: 6.0-inch deep panel, 18-inch width with perforations in the widest flange and webs.
4. ESW750: 7.5-inch deep panel, 18-inch width with perforations in the widest flange and webs.

The standard perforation pattern contains 3/8-inch diameter round holes on a 1/2-inch staggered pattern. The perforation pattern is designated by the Industrial Perforators Association as pattern # 124. The percent open area is 51%. The load tables are valid for other perforation pattern configurations provided that the round hole diameter, spacing and percent open are less than the standard. Solid panels without perforations are acceptable.



**MANUFACTURER:**  
 Epic Metals Corporation  
 11 Talbot Ave  
 Rankin, PA 15104  
[www.epicmetals.com](http://www.epicmetals.com)  
 (412) 351-3913

EPIC METALS "EST4 & ESW SERIES" (LARGE MISSILE IMPACT RATED) PERFORATED STEEL SUNSCREEN PANEL ENGINEERING REPORT

DATE:	9/14/23
PAGE #:	2 OF 13
REPORT #:	23-616-Epic-LMI-ER
REVISES #:	22-489-Epic-LMI-ER
PM:	DG
REVISIONS:	9/14/23

**CBUCK Engineering**  
 Specialty Structural Engineering  
 CBUCK, Inc. COA #8064  
 www.cbuckinc.net  
 (561) 491-9927  
 1374 Community Dr  
 Jupiter, FL 33458

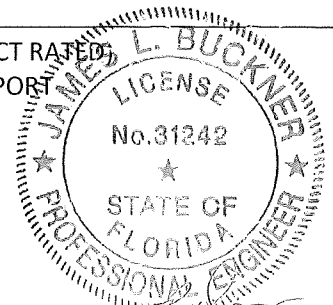

Date: 9/14/23

4.2 Panel Dimensions:

4.2.1 Refer to panel drawings.

4.3 Section Properties

Deck Type	Gage	Weight (psf)	Moment of Inertia, I (in4/ft)	Section Modulus, S (in3/ft)
EST4	18	3.4	1.71	0.58
	16	4.3	2.13	0.75
ESW450	16	3.1	1.95	0.56
	14	3.9	2.49	0.75
ESW600	16	3.4	4.00	0.75
	14	4.3	5.09	1.10
ESW750	16	3.8	6.49	0.92
	14	4.7	8.80	1.39

Note: Values based on a steel yield strength of 40,000 psi

5.0 Support:

The Support assembly is designed by others and shall have the following minimum Characteristics:

- 5.1 Type: Horizontal or Vertical framing members
- 5.2 Material: Steel
- 5.3 Thickness: 3/16 in. Minimum Structural Steel (Flange Thickness)
- 5.4 Yield Strength: 46 ksi Minimum
- 5.5 Support Spacing: Refer to Table Below

**PRODUCT RENEWED**  
as complying with the Florida  
Building Code  
NOA-No. 24-0311.05

Expiration Date 05/23/2029

By [Signature]  
Miami-Dade Product Control

**PRODUCT REVISED**  
as complying with the Florida  
Building Code  
NOA-No. 23-0926.10

Expiration Date 05/23/2024

By [Signature]  
Miami-Dade Product Control



MANUFACTURER:  
Epic Metals Corporation  
11 Talbot Ave  
Rankin, PA 15104  
[www.epicmetals.com](http://www.epicmetals.com)  
(412) 351-3913

EPIC METALS "EST4 & ESW SERIES" (LARGE MISSILE IMPACT RATED)  
PERFORATED STEEL SUNSCREEN PANEL ENGINEERING REPORT

DATE:	9/14/23
PAGE #:	3 OF 13
REPORT #:	23-616-Epic-LMI-ER
REVISES #:	22-489-Epic-LMI-ER
PM:	DG
REVISIONS:	9/14/23

**CBUCK Engineering**  
Specialty Structural Engineering  
CBUCK, Inc. COA #8064  
[www.cbuckinc.net](http://www.cbuckinc.net)  
(561) 491-9927  
1374 Community Dr  
Jupiter, FL 33458

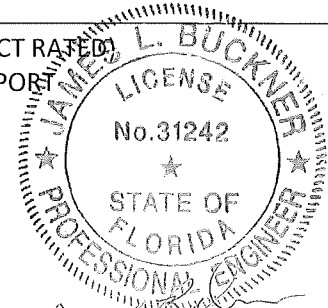

Date: 9/14/23

**6.0 Performance:**

**6.1 Span Tables:**

**6.1.1 Table 2-1: EST 4 Uniform Allowable Design Pressures – (PSF)**

Sunscreen Panel Model	Panel Span Condition	Sunscreen Panel Gage	Number of Fasteners Per Panel Flute Per Support	Uniform Allowable Design Pressures, PSF				
				Span Length, Center to Center of Supports (ft.)				
				8	10	12	14	16
EST 4	Simple or Multiple	18	1	146	119	97	73	48
		16	1	149	119	100	85	71
		18	2	146	122	97	73	48
		16	2	188	159	129	100	71

**6.1.2 Table 2-2: ESW 450 Uniform Allowable Design Pressures – (PSF)**

Sunscreen Panel Model	Panel Span Condition	Sunscreen Panel Gage	Number of Fasteners Per Panel Flute Per Support	Uniform Allowable Design Pressures, PSF					
				Span Length, Center to Center of Supports (ft.)					
				8	10	12	14	16	18
ESW450	Simple or Multiple	16	1	67	53	44	38	-	-
		14	1	73	58	49	42	37	32
		16	2	120	95	74	57	-	-
		14	2	146	117	97	83	70	48

**6.1.3 Table 2-3: ESW 600 Uniform Allowable Design Pressures – (PSF)**

Sunscreen Panel Model	Panel Span Condition	Sunscreen Panel Gage	Number of Fasteners Per Panel Flute Per Support	Uniform Allowable Design Pressures, PSF					
				Span Length, Center to Center of Supports (ft.)					
				8	10	12	14	16	18
ESW600	Simple Or Multiple	16	1	67	53	44	38	-	-
		14	1	73	58	49	42	37	32
		16	2	120	95	74	57	-	-
		14	2	146	117	97	83	70	48

**6.1.4 Table 2-4: ESW 750 Uniform Allowable Design Pressures – (PSF)**

Sunscreen Panel Model	Panel Span Condition	Sunscreen Panel Gage	Number of Fasteners Per Panel Flute Per Support	Uniform Allowable Design Pressures, PSF			
				Span Length, Center to Center of Supports (ft.)			
				14	16	18	19
ESW750	Single or Multiple	16	1	38	33	30	28
		14	1	42	37	32	31
		16	2	64	55	47	43
		14	2	83	73	65	61

Notes for Tables 2-1 thru 2-4:

1. Design Pressures are based on ASD design.
2. See Table 2-5 for the allowable loads for fastening the panels to the steel supports.
3. Use linear interpolation to obtain load values for unlisted spans within ranges provided in above tables.



MANUFACTURER:  
Epic Metals Corporation  
11 Talbot Ave  
Rankin, PA 15104  
[www.epicmetals.com](http://www.epicmetals.com)  
(412) 351-3913

EPIC METALS "EST4 & ESW SERIES" (LARGE MISSILE IMPACT RATED)  
PERFORATED STEEL SUNSCREEN PANEL ENGINEERING REPORT

DATE: 9/14/23  
PAGE #: 4 OF 13  
REPORT #: 23-616-Epic-LMI-ER  
REVISES #: 22-489-Epic-LMI-ER  
PM: DG  
REVISIONS: 9/14/23

**CBUCK Engineering**  
Specialty Structural Engineering  
CBUCK, Inc. COA #8064  
www.cbuckinc.net  
(561) 491-9927  
1374 Community Dr  
Jupiter, FL 33458

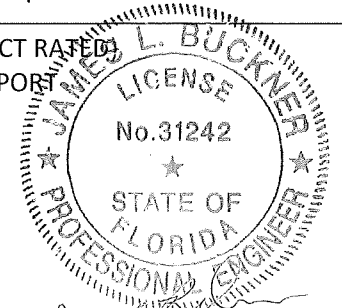

Date: 9/14/23



6.1.5 Table 2-3: Design Loads for Fasteners Through Solid Material (lbs)

	Substrate	Screw = 12-24 x 1-1/2" Elco Part# EAJ320 Bi-Flex w/ 9/16" outside diameter & neoprene-backed washer.  Note: $\Omega = 3.0$ (Per AISI for pullout in steel)
	3/16" Structural Steel	
Deck Gauge	$R_n/\Omega$	
20	710	
18	795	
14	871	

Tension Capacity values for connections based on FET Test T191-17  
Assumes panel properties of  $F_y = 40$  ksi,  $F_u = 55$  ksi.

7.0 Installation:

7.1 Attaching to Structural Steel Substrate: Each panel is fastened at each end to steel supports with (1) or (2) #12-24 X 1-1/2" ELCO Bi-Flex 300 Series SS Self Drilling Fasteners (P/N EAJ 320 Bi-Flex) w/ 9/16" diameter neoprene-backed washers per Tables 2-1 thru 2-4. Connection patterns are shown on pages 10-13.

8.0 Limitations of Use:

- 8.1 The panel supports shall be 3/16" thick minimum structural steel.
- 8.2 Maximum support spacing shall not be exceeded.
- 8.3 The panels shall be supported by structural framing members complying with the The Florida Building Code, Chapter 22, including Florida High velocity zone.
- 8.4 Panel shall not be used as axial load bearing components and shall not be intended / designed to act as a diaphragm.
- 8.5 The engineer of record or architect shall verify that the supporting structure is capable of resisting the superimposed loads from the wall panel system and that the supporting structure is capable of providing lateral stability to carry the wind loads to the building foundation.

9.0 Code Compliance

9.1 Product meets the High Velocity Hurricane Zone (HVHZ) Requirements of the Florida Building Code, 8th Edition (2023) for the properties evaluated.

10.0 Identification:

10.1 Each Panel shall bear a permanent label with the manufacturer's name or logo, manufacturing plant's city, state and the statement reading "Miami-Dade County Product Control Approved" is to be located on each panel.

**PRODUCT RENEWED**  
as complying with the Florida  
Building Code  
NOA-No. 24-0311.05  
Expiration Date 05/23/2029  
By [Signature]  
Miami-Dade Product Control

**PRODUCT REVISED**  
as complying with the Florida  
Building Code  
NOA-No. 23-0926.10  
Expiration Date 05/23/2024  
By [Signature]  
Miami-Dade Product Control

**EPIC METALS™**  
MANUFACTURER:  
Epic Metals Corporation  
11 Talbot Ave  
Rankin, PA 15104  
[www.epicmetals.com](http://www.epicmetals.com)  
(412) 351-3913

EPIC METALS "EST4 & ESW SERIES" (LARGE MISSILE IMPACT RATED)  
PERFORATED STEEL SUNSCREEN PANEL ENGINEERING REPORT

DATE: 9/14/23  
PAGE #: 5 OF 13  
REPORT #: 23-616-Epic-LMI-ER  
REVISES #: 22-489-Epic-LMI-ER  
PM: DG  
REVISIONS: 9/14/23

**CBUCK Engineering**  
Specialty Structural Engineering  
CBUCK, Inc. COA #8064  
[www.cbuckinc.net](http://www.cbuckinc.net)  
(561) 491-9927  
1374 Community Dr  
Jupiter, FL 33458

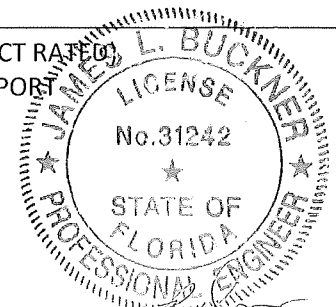

Date: 9/14/23

**11.0 Reference Data:**

- 11.1 TAS 202 – Uniform Static Air Pressure Test.  
Report No.: T224-17 Report Date: 7/31/17  
By: Farabaugh Engineering & Testing, Inc.
- 11.2 TAS 202 – Uniform Static Air Pressure Test.  
Report No.: T225-17 Report Date: 7/31/17  
(ESW 750, 14 ga @ 14' & 18 ga @ 19')  
By: Farabaugh Engineering & Testing, Inc.
- 11.3 TAS 202 – Uniform Static Air Pressure Test.  
Report No.: T226-17 Report Date: 7/31/17  
(EST 4, 16 ga @ 8', 16 ga @ 19', 20 ga. @ 16')  
By: Farabaugh Engineering & Testing, Inc.
- 11.4 TAS 202 – Uniform Static Air Pressure Test.  
Report No.: T194-18 Report Date: 5/25/18  
(ESW 750, 18 ga @ 14')  
By: Farabaugh Engineering & Testing, Inc.
- 11.5 TAS 202 – Uniform Static Air Pressure Test.  
Report No.: T220-18Rev Report Date: 10/26/18  
By: Farabaugh Engineering & Testing, Inc.
- 11.6 TAS 202 – Uniform Static Air Pressure Test.  
Report No.: T224-18 Report Date: 6/22/18  
By: Farabaugh Engineering & Testing, Inc.
- 11.7 TAS 202 – Uniform Static Air Pressure Test.  
Report No.: T225-18 Report Date: 6/22/18  
(EST 4, 20 ga @ 8')  
By: Farabaugh Engineering & Testing, Inc.
- 11.8 TAS 203 – Cyclic Wind Pressure Loading Test  
Report No.: T263-18 Report Date: 9/21/18, Rev 1/26/19  
(EST 4, 16 ga @ 8', 20 ga @ 8', 20 ga @ 16')  
By: Farabaugh Engineering & Testing, Inc.
- 11.9 TAS 203 – Cyclic Wind Pressure Loading Test  
Report No.: T264-18 Report Date: 10/31/18  
By: Farabaugh Engineering & Testing, Inc.
- 11.10 TAS 203 – Cyclic Wind Pressure Loading Test  
Report No.: T265-18 Report Date: 9/18/18  
(ESW 750, 14 ga @ 14', 18 ga @ 14', 18 ga @ 19')  
By: Farabaugh Engineering & Testing, Inc.
- 11.11 ASTM-E8-09 – Tensile Test  
Report No.: T246-18 Report Date: 7/24/18  
(EST 4 – 20 ga, ESW 450- 14 ga & 18 ga, ESW 750 - 14 ga & 18 ga)  
By: Farabaugh Engineering & Testing, Inc.
- 11.12 TAS 201-94 Large Missile Impact Test & TAS 203 – Cyclic Wind Pressure Loading Test  
Report No.: T345-22(1) Report Date: 1/5/23  
(EST 4, 18 ga, 18 ga @ 16')  
By: Farabaugh Engineering & Testing, Inc.

**PRODUCT RENEWED**  
as complying with the Florida  
Building Code  
NOA-No. 24-0311.05

Expiration Date 05/23/2029

By *RH*  
Miami-Dade Product Control

**PRODUCT REVISED**  
as complying with the Florida  
Building Code  
NOA-No. 23-0926.10

Expiration Date 05/23/2024

By *RH*  
Miami-Dade Product Control

**EPIC METALS™**

MANUFACTURER:  
Epic Metals Corporation  
11 Talbot Ave  
Rankin, PA 15104  
[www.epicmetals.com](http://www.epicmetals.com)  
(412) 351-3913

EPIC METALS "EST4 & ESW SERIES" (LARGE MISSILE IMPACT RATED)  
PERFORATED STEEL SUNSCREEN PANEL ENGINEERING REPORT

DATE:	9/14/23
PAGE #:	6 OF 13
REPORT #:	23-616-Epic-LMI-ER
REVISES #:	22-489-Epic-LMI-ER
PM:	DG
REVISIONS:	9/14/23

**CBUCK Engineering**  
Specialty Structural Engineering  
CBUCK, Inc. COA #8064  
[www.cbuckinc.net](http://www.cbuckinc.net)  
(561) 491-9927  
1374 Community Dr  
Jupiter, FL 33458

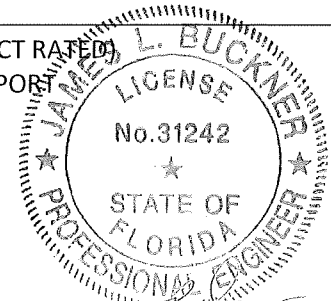

Date: 9/14/23

- 11.13 TAS 201-94 Large Missile Impact Test & TAS 203 – Cyclic Wind Pressure Loading Test  
Report No.: T346-22(1) Report Date: 1/5/23  
(ESW 750, 16 ga, 16 ga @ 19')  
By: Farabaugh Engineering & Testing, Inc.
- 11.14 Engineering Analysis/Calculations  
Report Number: 22-489-Epic-LMI-EA Report Date: 3/06/23  
By: James L Buckner, P.E.

**PRODUCT RENEWED**  
as complying with the Florida  
Building Code  
NOA-No. 24-0311.05

Expiration Date 05/23/2029

By *[Signature]*  
Miami-Dade Product Control

**PRODUCT REVISED**  
as complying with the Florida  
Building Code  
NOA-No. 23-0926.10

Expiration Date 05/23/2024

By *[Signature]*  
Miami-Dade Product Control

**EPIC METALS™**

MANUFACTURER:  
Epic Metals Corporation  
11 Talbot Ave  
Rankin, PA 15104  
[www.epicmetals.com](http://www.epicmetals.com)  
(412) 351-3913

EPIC METALS "EST4 & ESW SERIES" (LARGE MISSILE IMPACT RATED)  
PERFORATED STEEL SUNSCREEN PANEL ENGINEERING REPORT

DATE:	9/14/ 23
PAGE #:	7 OF 13
REPORT #:	23-616-Epic-LMI-ER
REVISES #:	22-489-Epic-LMI-ER
PM:	DG
REVISIONS:	9/14/23

**CBUCK Engineering**  
Specialty Structural Engineering  
CBUCK, Inc. COA #8064  
[www.cbuckinc.net](http://www.cbuckinc.net)  
(561) 491-9927  
1374 Community Dr  
Jupiter, FL 33458

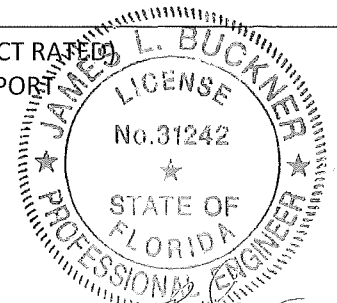

*[Signature]*  
Date: 9/14/23

**12.0 Product Components:**

**PRODUCT RENEWED**  
as complying with the Florida  
Building Code  
NOA-No. 24-0311.05

**12.1 EST 4 Series Perforated Steel Sunscreen Panel**

The panel is a 4" deep perforated steel panel.

Material: Steel  
Thickness: 16 Gauge Max - 18 Gauge Min  
(t = 0.0600 in Max. - t = 0.0358 in Min)  
Yield Strength: 40.0 ksi Minimum  
Corrosion Resistance: Galvanized Steel per ASTM A653 G-90

Expiration Date 05/23/2029

By [Signature]  
**Miami-Dade Product Control**

**12.2 ESW 450 Series Perforated Steel Sunscreen Panel**

The panel is a 4.5" deep perforated steel panel.

Material: Steel  
Thickness: 14 Gauge Max - 16 Gauge Min  
(t = 0.0747 in Max. - t = 0.0474 in Min)  
Yield Strength: 40.0 ksi Minimum  
Corrosion Resistance: Galvanized Steel per ASTM A653 G-90

**12.3 ESW 600 Series Perforated Steel Sunscreen Panel**

The panel is a 6" deep perforated steel panel.

Material: Steel  
Thickness: 14 Gauge Max - 16 Gauge Min  
(t = 0.0747 in Max. - t = 0.0474 in Min)  
Ultimate Yield Strength: 40.0 ksi Minimum  
Corrosion Resistance: Galvanized Steel per ASTM A653 G-90

**12.4 ESW 750 Series Perforated Steel Sunscreen Panel**

The panel is a 7.5" deep perforated steel panel.

Material: Steel  
Thickness: 14 Gauge Max - 16 Gauge Min  
(t = 0.0747 in Max. - t = 0.0474 in Min)  
Yield Strength: 40.0 ksi Minimum  
Corrosion Resistance: Galvanized Steel per ASTM A653 G-90

**12.5 Fasteners:**

Specification/standard for fasteners to be used at intermediate and end steel supports.

Material: Stainless Steel  
Name: ELCO Bi-Flex 300 Series SS Self Drilling Fasteners  
Type: ELCO P/N EAJ 320 Bi-Flex  
Diameter: Fastener: #12-24 Washer: 9/16" diameter  
Length: 1-1/2" minimum (Must penetrate steel support min 3/4")  
Corrosion Resistance: Stainless Steel per ASTM A240

**PRODUCT REVISED**  
as complying with the Florida  
Building Code  
NOA-No. 23-0926.10

Expiration Date 05/23/2024

By [Signature]  
**Miami-Dade Product Control**



MANUFACTURER:  
Epic Metals Corporation  
11 Talbot Ave  
Rankin, PA 15104  
[www.epicmetals.com](http://www.epicmetals.com)  
(412) 351-3913

EPIC METALS "EST4 & ESW SERIES" (LARGE MISSILE IMPACT RATED)  
PERFORATED STEEL SUNSCREEN PANEL ENGINEERING REPORT

DATE:	9/14/23
PAGE #:	8 OF 13
REPORT #:	23-616-Epic-LMI-ER
REVISES #:	22-489-Epic-LMI-ER
PM:	DG
REVISIONS:	9/14/23

**CBUCK Engineering**  
Specialty Structural Engineering  
CBUCK, Inc. COA #8064  
[www.cbuckinc.net](http://www.cbuckinc.net)  
(561) 491-9927  
1374 Community Dr  
Jupiter, FL 33458

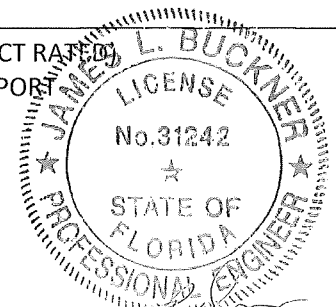

Date: 9/14/23

**EPIC METALS CORP.**  
**"EST 4" & "ESW Series" PROFILE DRAWINGS**

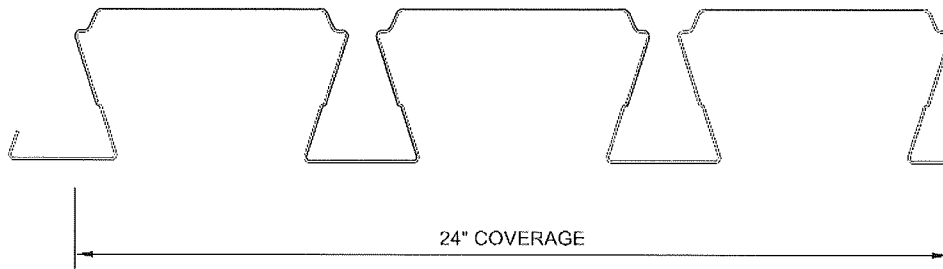

**"EST 4" TYPICAL PANEL PROFILE**

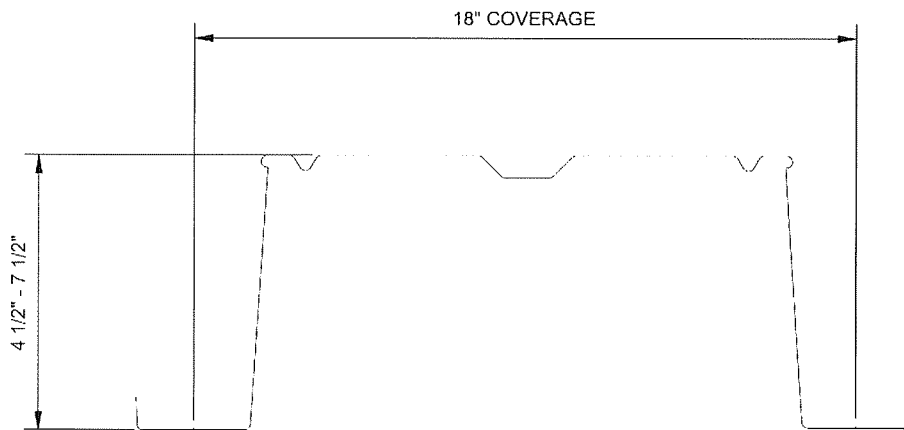

**"ESW 450", "ESW 600" AND "ESW 750" TYPICAL PANEL PROFILES**

**PRODUCT RENEWED**  
as complying with the Florida  
Building Code  
NOA-No. 24-0311.05

Expiration Date 05/23/2029

By *R. H. [Signature]*  
Miami-Dade Product Control

**PRODUCT REVISED**  
as complying with the Florida  
Building Code  
NOA-No. 23-0926.10

Expiration Date 05/23/2024

By *R. H. [Signature]*  
Miami-Dade Product Control

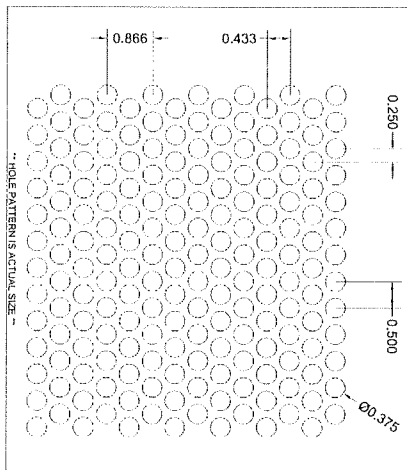

**STANDARD PERFORATED PATTERN (PATTERN #124) - ROUND HOLE 3/8" DIAMETER (1/2" STAGGERED)**

**EPIC METALS™**

MANUFACTURER:  
Epic Metals Corporation  
11 Talbot Ave  
Rankin, PA 15104  
www.epicmetals.com  
(412) 351-3913

EPIC METALS "EST4 & ESW SERIES" (LARGE MISSILE IMPACT RATED)  
PERFORATED STEEL SUNSCREEN PANEL ENGINEERING REPORT

DATE: 9/14/23  
PAGE #: 9 OF 13  
REPORT #: 23-616-Epic-LMI-ER  
REVISES #: 22-489-Epic-LMI-ER  
PM: DG  
REVISIONS: 9/14/23

**CBUCK Engineering**  
Specialty Structural Engineering  
**CBUCK, Inc.** COA #8064  
www.cbuckinc.net  
(561) 491-9927  
1374 Community Dr  
Jupiter, FL 33458

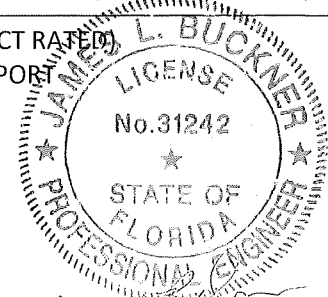

Date: 9/14/23

**PRODUCT RENEWED**  
 as complying with the Florida  
 Building Code  
 NOA-No. 24-0311.05

Expiration Date 05/23/2029

By   
 Miami-Dade Product Control

**EPIC METALS CORP.**  
**"EST 4" INSTALLATION DRAWINGS**

#12-24 SS SELF  
 DRILLING  
 SCREW PER REPORT IN  
 24/3 PATTERN

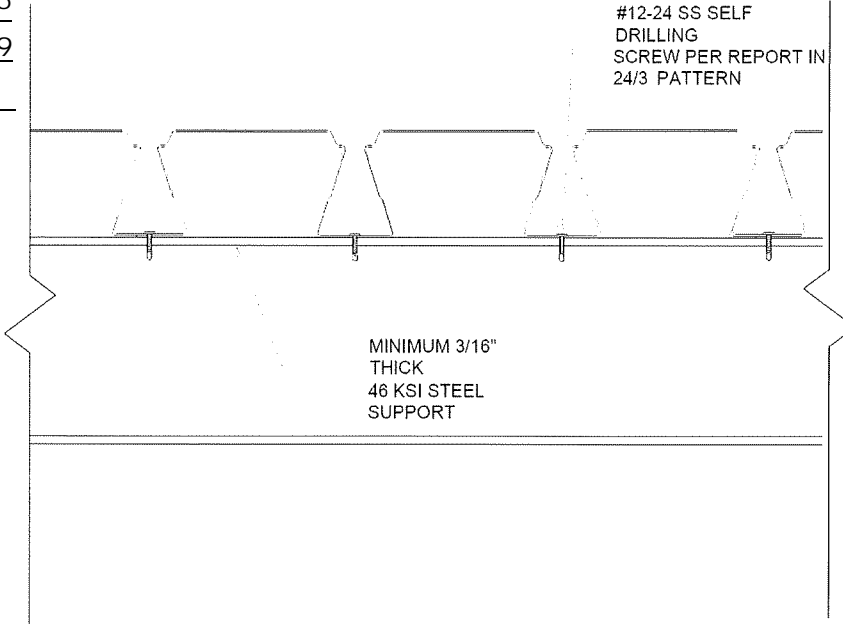

MINIMUM 3/16"  
 THICK  
 46 KSI STEEL  
 SUPPORT

**PRODUCT REVISED**  
 as complying with the Florida  
 Building Code  
 NOA-No. 23-0926.10

Expiration Date 05/23/2024

By   
 Miami-Dade Product Control

"EST 4" ATTACHMENT WITH ONE (1) FASTENER PER FLUTE

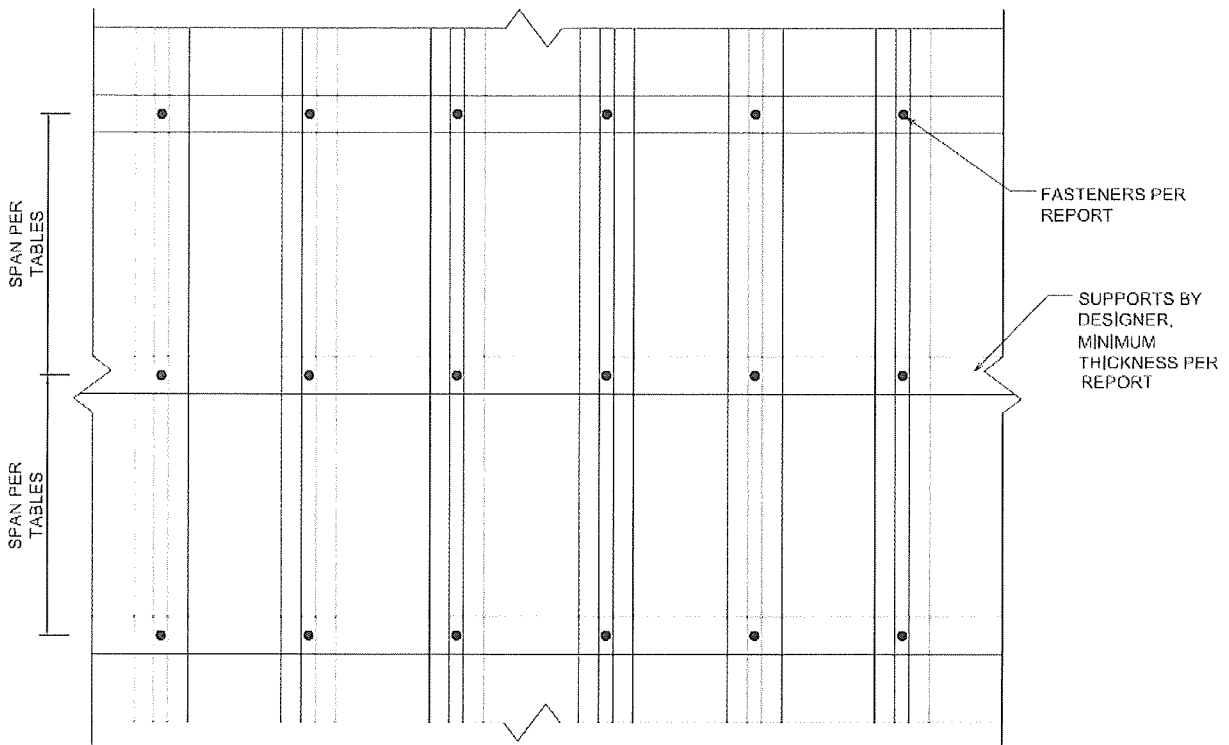

"EST 4" ELEVATION WITH ONE (1) FASTENER PER FLUTE



MANUFACTURER:  
 Epic Metals Corporation  
 11 Talbot Ave  
 Rankin, PA 15104  
[www.epicmetals.com](http://www.epicmetals.com)  
 (412) 351-3913

EPIC METALS "EST4 & ESW SERIES" (LARGE MISSILE IMPACT RATED)  
 PERFORATED STEEL SUNSCREEN PANEL ENGINEERING REPORT

DATE:	9/14/23
PAGE #:	10 OF 13
REPORT #:	23-616-Epic-LMI-ER
REVISES #:	22-489-Epic-LMI-ER
PM:	DG
REVISIONS:	9/14/23

 **CBUCK Engineering**  
 Specialty Structural Engineering  
 CBUCK, Inc. COA #8064  
[www.cbuckinc.net](http://www.cbuckinc.net)  
 (561) 491-9927  
 1374 Community Dr  
 Jupiter, FL 33458

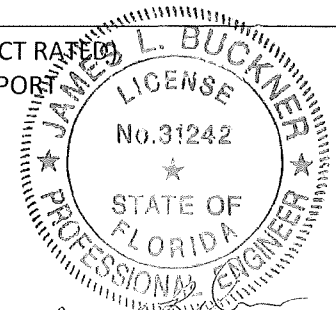

Date: 9/14/23

**PRODUCT RENEWED**  
 as complying with the Florida  
 Building Code  
 NOA-No. 24-0311.05

Expiration Date 05/23/2029

By *[Signature]*  
 Miami-Dade Product Control

**PRODUCT REVISED**  
 as complying with the Florida  
 Building Code  
 NOA-No. 23-0926.10

Expiration Date 05/23/2024

By *[Signature]*  
 Miami-Dade Product Control

**EPIC METALS CORP.**

**"EST 4" INSTALLATION DRAWINGS**

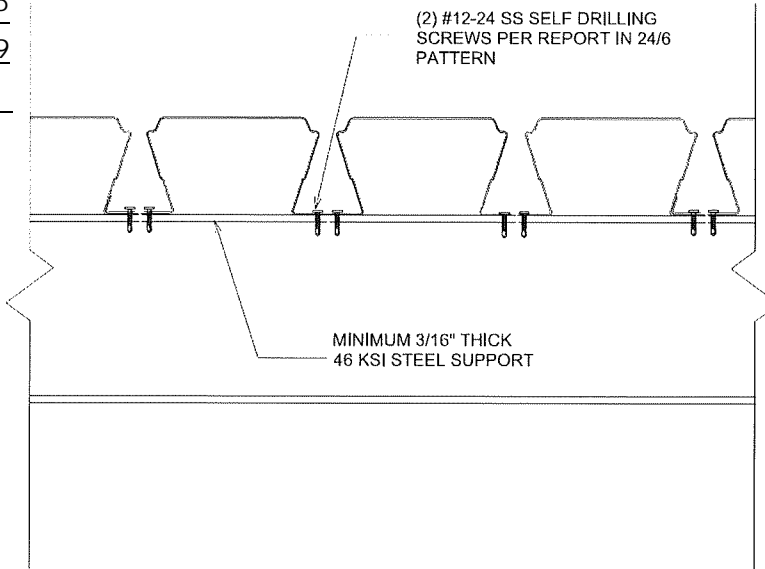

**"EST 4" ATTACHMENT WITH TWO (2) FASTENERS PER FLUTE**

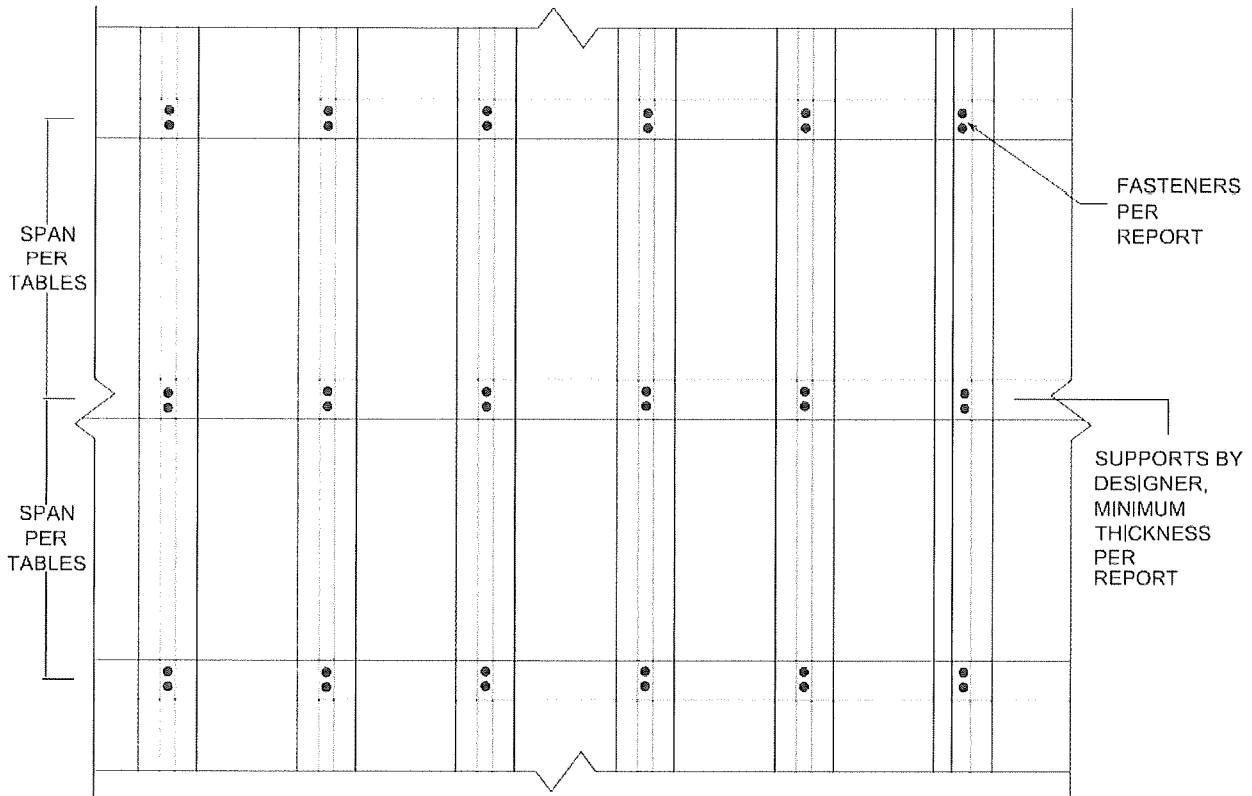

**"EST 4" ELEVATION WITH TWO (2) FASTENERS PER FLUTE**



**MANUFACTURER:**  
 Epic Metals Corporation  
 11 Talbot Ave  
 Rankin, PA 15104  
[www.epicmetals.com](http://www.epicmetals.com)  
 (412) 351-3913

EPIC METALS "EST4 & ESW SERIES" (LARGE MISSILE IMPACT RATED)  
 PERFORATED STEEL SUNSCREEN PANEL ENGINEERING REPORT

DATE:	9/14/23
PAGE #:	11 OF 13
REPORT #:	23-616-Epic-LMI-ER
REVISES #:	22-489-Epic-LMI-ER
PM:	DG
REVISIONS:	9/14/23

**CBUCK Engineering**  
 Specialty Structural Engineering  
 CBUCK, Inc. COA #8064  
[www.cbuckinc.net](http://www.cbuckinc.net)  
 (561) 491-9927  
 1374 Community Dr  
 Jupiter, FL 33458

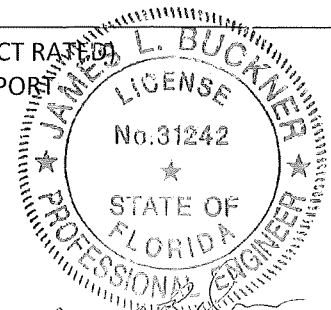

Date: 9/14/23

**PRODUCT RENEWED**  
 as complying with the Florida  
 Building Code  
 NOA-No. 24-0311.05

Expiration Date 05/23/2029

By [Signature]  
 Miami-Dade Product Control

**EPIC METALS CORP.**  
**"ESW Series" INSTALLATION DRAWINGS**

#12-24 55 SELF  
 DRILLING SCREW  
 PER REPORT IN 16" PATTERN

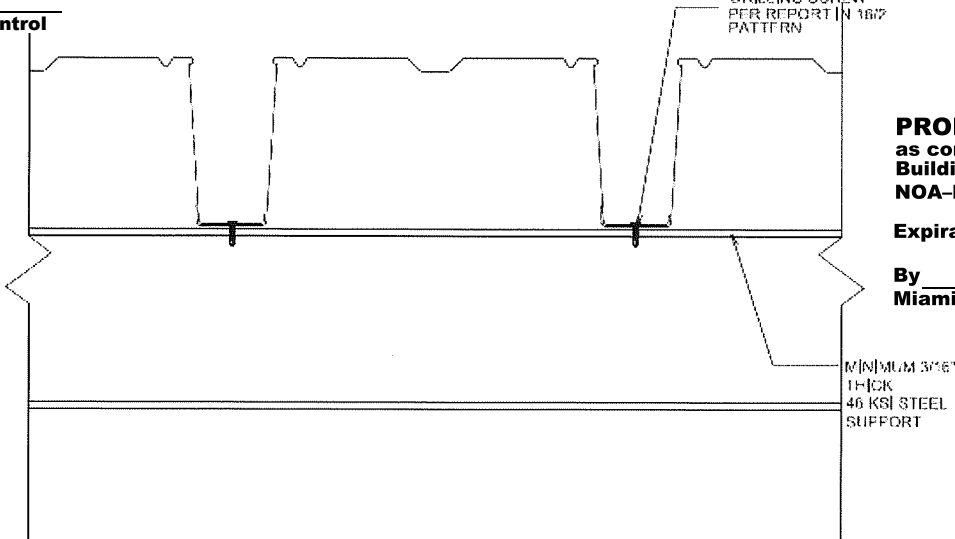

**PRODUCT REVISED**  
 as complying with the Florida  
 Building Code  
 NOA-No. 23-0926.10

Expiration Date 05/23/2024

By [Signature]  
 Miami-Dade Product Control

MINIMUM 3/16"  
 THICK  
 46 KSI STEEL  
 SUPPORT

**"ESW 450, 600 & 750" ATTACHMENT WITH ONE (1) FASTENER PER FLUTE**

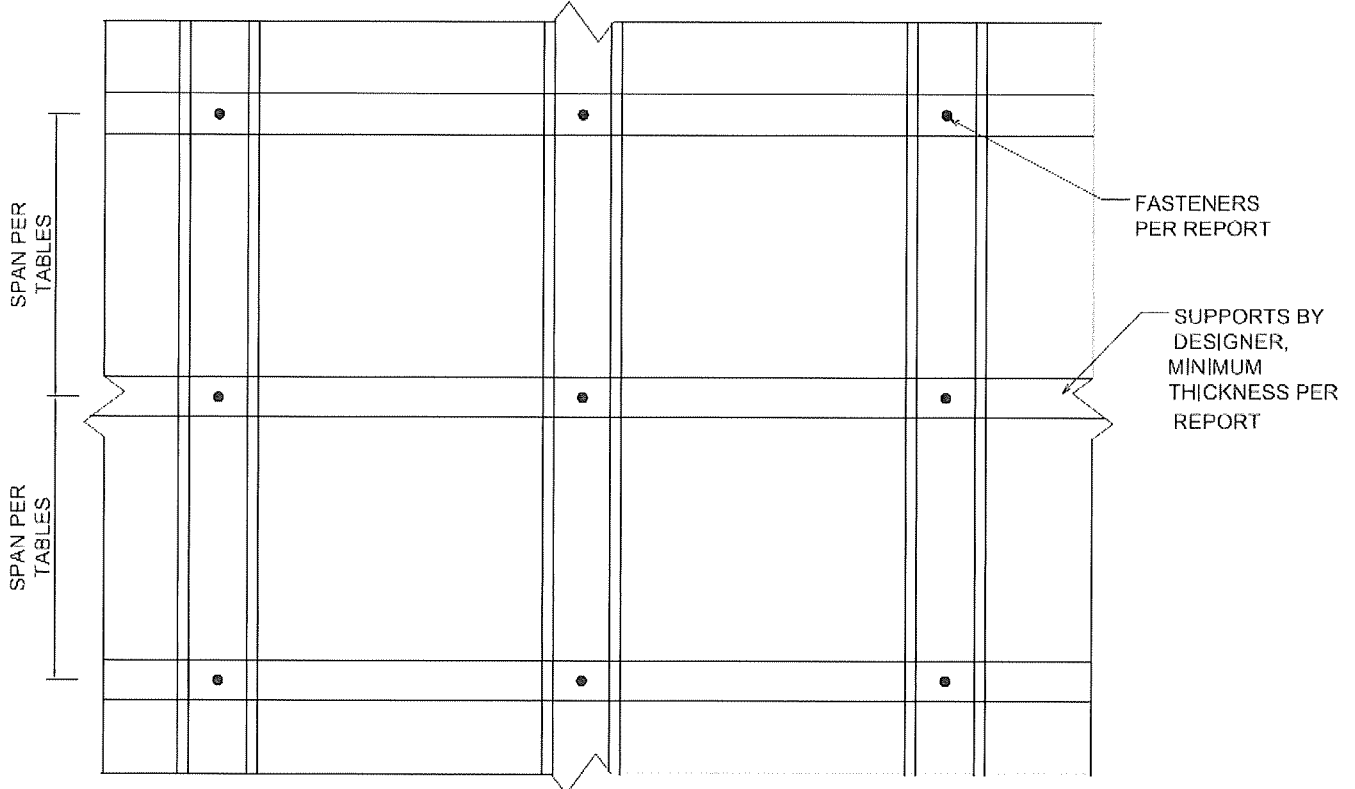

**"ESW 450, 600 & 750" ELEVATION WITH ONE (1) FASTENER PER FLUTE**

**EPIC METALS™**

MANUFACTURER:  
 Epic Metals Corporation  
 11 Talbot Ave  
 Rankin, PA 15104  
[www.epicmetals.com](http://www.epicmetals.com)  
 (412) 351-3913

EPIC METALS "EST4 & ESW SERIES" (LARGE MISSILE IMPACT RATED)  
 PERFORATED STEEL SUNSCREEN PANEL ENGINEERING REPORT

DATE: 9/14/23  
 PAGE #: 12 OF 13  
 REPORT #: 23-616-Epic-LMI-ER  
 REVISES #: 22-489-Epic-LMI-ER  
 PM: DG  
 REVISIONS: 9/14/23

**CBUCK Engineering**  
 Specialty Structural Engineering  
 CBUCK, Inc. COA #8064  
 www.cbuckinc.net  
 (561) 491-9927  
 1374 Community Dr  
 Jupiter, FL 33458

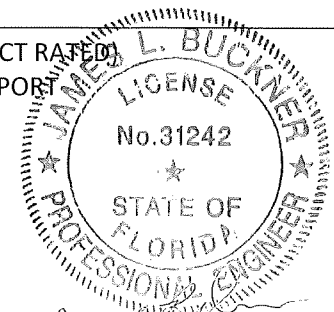

Date: 9/14/23



**PRODUCT RENEWED**  
 as complying with the Florida  
 Building Code  
 NOA-No. 24-0311.05

**EPIC METALS CORP.**

**"ESW Series" INSTALLATION DRAWINGS**

Expiration Date 05/23/2029

By *[Signature]*  
 Miami-Dade Product Control

#12-24 SS SELF  
 DRILLING SCREW  
 PER REPORT IN 18/2  
 PATTERN

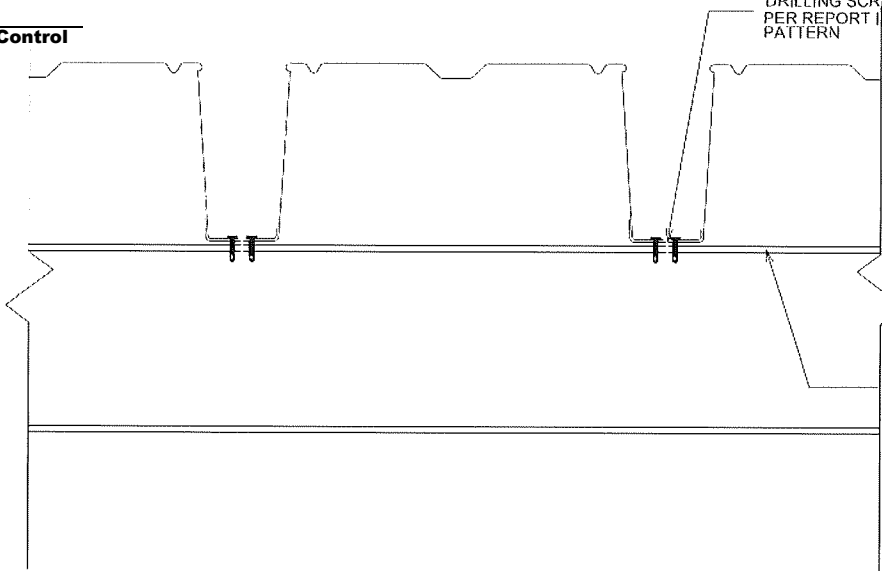

**PRODUCT REVISED**  
 as complying with the Florida  
 Building Code  
 NOA-No. 23-0926.10

Expiration Date 05/23/2024

By *[Signature]*  
 Miami-Dade Product Control

MINIMUM 3/16"  
 THICK  
 46 KSI STEEL  
 SUPPORT

**"ESW 450, 600 & 750" ATTACHMENT WITH TWO (2) FASTENERS PER FLUTE**

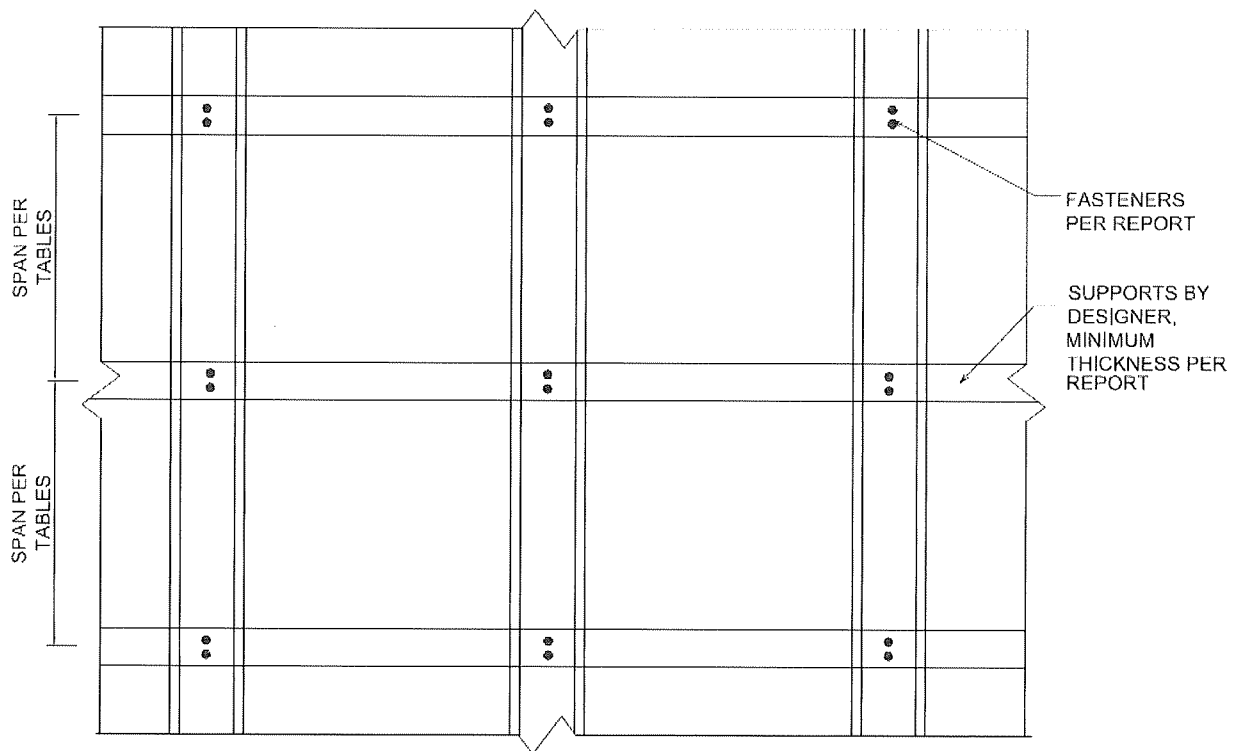

**"ESW 450, 600 & 750" ELEVATION WITH TWO (2) FASTENERS PER FLUTE**

**EPIC METALS™**

MANUFACTURER:  
 Epic Metals Corporation  
 11 Talbot Ave  
 Rankin, PA 15104  
[www.epicmetals.com](http://www.epicmetals.com)  
 (412) 351-3913

EPIC METALS "EST4 & ESW SERIES" (LARGE MISSILE IMPACT RATED)  
 PERFORATED STEEL SUNSCREEN PANEL ENGINEERING REPORT

DATE: 9/14/23  
 PAGE #: 13 OF 13  
 REPORT #: 23-616-Epic-LMI-ER  
 REVISES #: 22-489-Epic-LMI-ER  
 PM: DG  
 REVISIONS: 9/14/23

**CBUCK Engineering**  
 Specialty Structural Engineering  
 CBUCK, Inc. COA #8064  
[www.cbuckinc.net](http://www.cbuckinc.net)  
 (561) 491-9927  
 1374 Community Dr  
 Jupiter, FL 33458

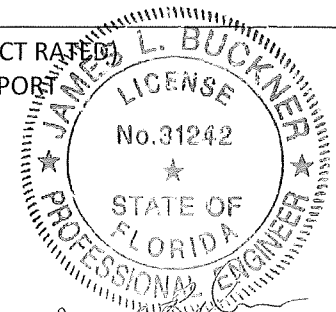

Date: 9/14/23