



MIAMI-DADE COUNTY
 PRODUCT CONTROL SECTION
 11805 SW 26 Street, Room 208
 Miami, Florida 33175-2474
 T (786) 315-2590 F (786) 315-2599
www.miamidade.gov/economy

DEPARTMENT OF REGULATORY AND ECONOMIC RESOURCES (RER)
 BOARD AND CODE ADMINISTRATION DIVISION
NOTICE OF ACCEPTANCE (NOA)

Loren Cook Company
2015 E. Dale Street
Springfield, MO 65803

SCOPE: This NOA is being issued under the applicable rules and regulations governing the use of construction materials. The documentation submitted has been reviewed and accepted by Miami-Dade County RER-Product Control Section to be used in Miami Dade County and other areas where allowed by the Authority Having Jurisdiction (AHJ).

This NOA shall not be valid after the expiration date stated below. The Miami-Dade County Product Control Section (In Miami Dade County) and/or the AHJ (in areas other than Miami Dade County) reserve the right to have this product or material tested for quality assurance purposes. If this product or material fails to perform in the accepted manner, the manufacturer will incur the expense of such testing and the AHJ may immediately revoke, modify, or suspend the use of such product or material within their jurisdiction. RER reserves the right to revoke this acceptance if it is determined by Miami-Dade County Product Control Section that this product or material fails to meet the requirements of the applicable building code.

This product is approved as described herein and has been designed to comply with the Florida Building Code, including the High Velocity Hurricane Zone.

DESCRIPTION: H Series Steel and Aluminum Rooftop Fans

APPROVAL DOCUMENT: Drawing No. **SD140501-75**, titled "H Series Propeller Fan Roof Mounted Hurricane Rated", sheets 1 through 8 of 8, dated 08/15/2015, prepared by Loren Cook Company, signed and sealed by Jerry T. Miller, P.E. on 02/16/2024, bearing the Miami-Dade County Product Control revision stamp with the Notice of Acceptance number and approval date by the Miami-Dade County Product Control Section.

MISSILE IMPACT RATING: Large and Small Missile Impact Resistant

LABELING: Each unit shall bear a permanent label with the manufacturer's name or logo, city, state, model/series, and following statement: "Miami-Dade County Product Control Approved", unless otherwise noted herein.

RENEWAL of this NOA shall be considered after a renewal application has been filed and there has been no change in the applicable building code negatively affecting the performance of this product.

TERMINATION of this NOA will occur after the expiration date or if there has been a revision or change in the materials, use, and/or manufacture of the product or process. Misuse of this NOA as an endorsement of any product, for sales, advertising or any other purposes shall automatically terminate this NOA. Failure to comply with any section of this NOA shall be cause for termination and removal of NOA.

ADVERTISEMENT: The NOA number preceded by the words Miami-Dade County, Florida, and followed by the expiration date may be displayed in advertising literature. If any portion of the NOA is displayed, then it shall be done in its entirety.

INSPECTION: A copy of this entire NOA shall be provided to the user by the manufacturer or its distributors and shall be available for inspection at the job site at the request of the Building Official.

This NOA **revises NOA # 21-0325.04** and consists of this page 1 and evidence pages E-1 and E-2, as well as approval document mentioned above.

The submitted documentation was reviewed by **Carlos M. Utrera, P.E.**



04/10/24

NOA No. 24-0311.09
 Expiration Date: May 12, 2026
 Approval Date: April 18, 2024

NOTICE OF ACCEPTANCE: EVIDENCE SUBMITTED

1. Evidence submitted under NOA # 15-1005.04

A. DRAWINGS

1. Drawing No. **SD140501-75**, titled “H Series Propeller Fan Roof Mounted Hurricane Rated”, sheets 1 through 8 of 8, dated 08/15/2015, prepared by Loren Cook Company, signed and sealed by Bradley F. Skidmore, P.E. on 02/11/2016.

B. TESTS

1. Test reports on 1) Uniform Static Air Pressure Test, Loading per FBC TAS 202-94
2) Large Missile Impact Test per FBC, TAS 201-94
along with marked-up drawings and installation diagram of H-Series Rooftop Ventilators, prepared by Intertek/Architectural Testing, Inc., Test Report No. **E0341.01-801-18**, dated 07/10/2015, with a revision dated 02/08/2016, signed and sealed by Tyler Westerling, P.E.

C. CALCULATIONS

1. Wind Loads and anchor calculations prepared by Loren Cook Company, dated 08/15/2015, signed and sealed by Bradley F. Skidmore, P.E.

D. QUALITY ASSURANCE

1. Miami-Dade Department of Regulatory and Economic Resources (RER).

E. MATERIAL CERTIFICATIONS

1. None.

F. STATEMENTS

1. Statement letter of code conformance to the 7th edition (2020) of the FBC issued by Loren Cook Company, dated 03/19/2021, signed and sealed by Bradley F. Skidmore, P.E.
“New Evidence Submitted”
2. Statement letter of code conformance to the 5th edition (2014) FBC issued by Loren Cook Company, dated 09/15/2015, signed and sealed by Bradley F. Skidmore, P.E.
3. Statement letter of no financial interest issued by Loren Cook Company, dated 09/15/2015, signed and sealed by Bradley F. Skidmore, P.E.



Carlos M. Utrera, P.E.
Product Control Examiner
NOA No. 24-0311.09
Expiration Date: May 12, 2026
Approval Date: April 18, 2024

NOTICE OF ACCEPTANCE: EVIDENCE SUBMITTED

2. NEW EVIDENCE SUBMITTED

A. DRAWINGS

1. Drawing No. **SD140501-75**, titled “H Series Propeller Fan Roof Mounted Hurricane Rated”, sheets 1 through 8 of 8, dated 08/15/2015, prepared by Loren Cook Company, signed and sealed by Jerry T. Miller, P.E. on 02/16/2024.

B. TESTS

1. None.

C. CALCULATIONS

1. None.

D. QUALITY ASSURANCE

1. Miami-Dade Department of Regulatory and Economic Resources (RER)

E. MATERIAL CERTIFICATIONS

1. None.

F. STATEMENTS

1. Statement letter of conformance, complying with 8th edition (2023) of the FBC, issued by Miller Engineering, dated 02/23/2024, signed and sealed by Jerry T. Miller, P.E.
2. Statement letter of no financial interest, issued by Miller Engineering, dated 02/23/2024, signed and sealed by Jerry T. Miller, P.E.



Carlos M. Utrera, P.E.
Product Control Examiner
NOA No. 24-0311.09
Expiration Date: May 12, 2026
Approval Date: April 18, 2024

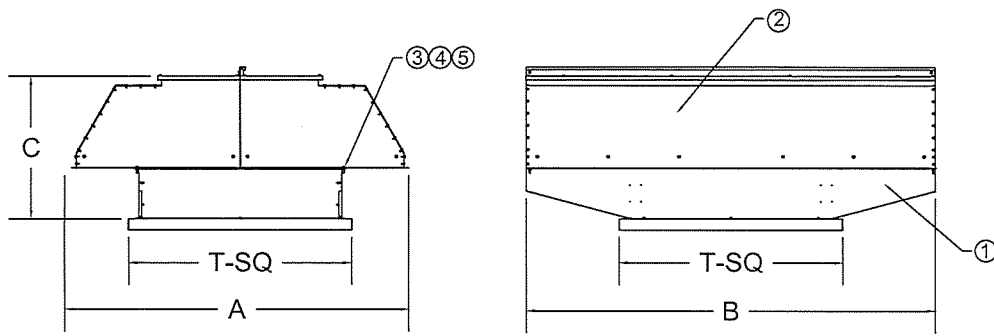



| | | | | | | |
|--|--------------------------------------|----------|----------|----------|---------|------------------------|
| 48 | | 90 | 110 | 41 1/2 | 60 | 1265 |
| | 42 | 90 | 110 | 41 1/2 | 54 | 1235 |
| 42 | | 90 | 90 | 38 | | 1155 |
| | 36 | 90 | 90 | 38 | 48 | 975 |
| 36 | | 80 | 80 | 33 | | 915 |
| | 30 | 80 | 80 | 33 | 42 | 710 |
| 30 | | 69 | 69 | 30 1/2 | | 660 |
| | 24 | 69 | 69 | 30 1/2 | 36 | 610 |
| 24 | | 59 | 59 | 28 3/4 | | 565 |
| | 20 | 59 | 59 | 28 3/4 | 32 | 520 |
| 20 | | 52 | 52 | 27 1/4 | | 470 |
| UNFILTERED UNIT SIZE | FILTERED UNIT SIZE | | | | | |
| BELT DRIVE MODELS HEE, HES, HXEL, HXEM HXSL, HXSM, HER | BELT DRIVE MODELS HEF, HXFL, HXFM | A DIM | B DIM | C DIM | T SQ | MAX. UNIT WEIGHT |
| DIRECT DRIVE MODELS HEE-D, HES-D, HER-D | DIRECT DRIVE MODELS HEF-D | | | | | |

NOTES:
 DESIGN PRESSURE: +/- 130PSF GALVANIZED STEEL HOOD
 +/- 70PSF ALUMINUM HOOD
 ALL DIMENSIONS IN INCHES.
 DESIGN, TESTING AND ATTACHMENT CONFORMS TO FLORIDA
 BUILDING CODE.
 MINIMUM SY=30KSI SHEET STEEL
 MINIMUM SY=17KSI SHEET ALUMINUM

| | | | |
|------|-----------------------|-------|----------|
| 5 | 3/8 USS WASHER (1 OD) | - | 4 |
| 4 | 3/8 NYLOC LOCKNUT | - | 4 |
| 3 | 3/8 X 1 HEX BOLT | - | 4 |
| 2 | HOOD ASSEMBLY | 8 | 1 |
| 1 | BASE ASSEMBLY | 4 | 1 |
| ITEM | DESCRIPTION | SHEET | QUANTITY |

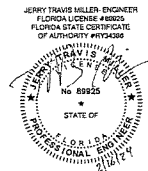
PRODUCT REVISED
 as complying with the Florida
 Building Code
 NOA-No. 24-0311.09
 Expiration Date 05/12/2026
 By *[Signature]*
 Miami-Dade Product Control



| | | |
|---|--------------------------|--------------|
| MAT'L | - | |
| DRAWN | BFS | 08/15/15 |
| DESIGNER | BFS | SHEET 1 OF 8 |
| DO NOT SCALE DRAWING TOLERANCES UNLESS OTHERWISE NOTED | | |
| DECIMAL | FRACTIONAL | |
| .XX=±.063" | ≤12"=±1/16" | |
| .XXX=±.010" | >12" THRU 96"=±1/8" | |
| .XXXX=±.001" | >96" THRU 144"=±1/4" | |
| ANGULAR | >144"=±3/8" | |
| ±2" | (NC)=NO INSPECTION REQ'D | |
|  LOREN COOK CO. MANUFACTURERS OF AIR MOVING EQUIPMENT SPRINGFIELD, MISSOURI | | |
| H SERIES PROPELLER FAN ROOF MOUNTED HURRICANE RATED | | |
| SIZE | DRAWING NO. | REV. |
| B | SD140501-75 | B |

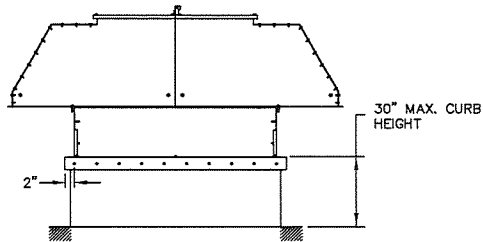

ATTACHMENT OF CURB TO ROOF STRUCTURE

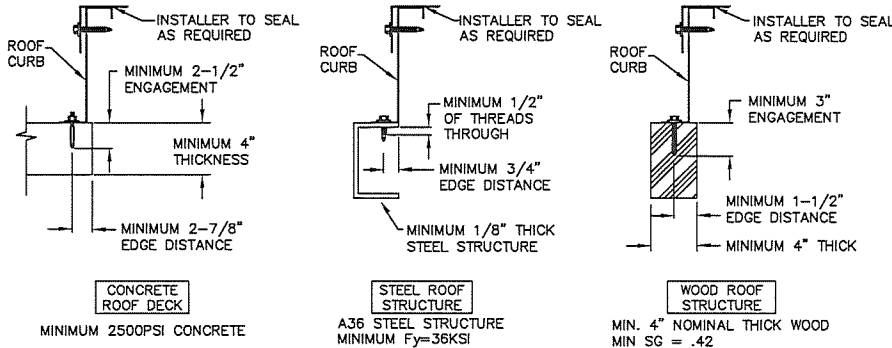

| FASTENER TABLE | | |
|----------------|---|---|
| UNIT SIZE | MINIMUM NUMBER OF FASTENERS PER SIDE TO ATTACH UNIT TO CURB | MINIMUM NUMBER OF FASTENERS PER SIDE TO ATTACH CURB TO ROOF STRUCTURE |
| 20 | 5 | 5 |
| 24 | 6 | 6 |
| 30 | 7 | 7 |
| 36 | 8 | 9 |
| 42 | 9 | 10 |
| 48 | 10 | 10 |

PRODUCT REVISED
as complying with the Florida Building Code

NOA-No. 24-0311.09

Expiration Date 05/12/2026

By *[Signature]*
Miami-Dade Product Control

NOTES:

- H-SERIES PROP FAN AS REFERRED TO HEREIN REFERS TO ALL LOREN COOK MODEL ROOF MOUNT POWER VENTILATORS INCLUDING BOTH DIRECT DRIVE AND BELT DRIVE TYPE UNITS WHICH ARE CONSTRUCTED WITH THE SAME OUTER HOUSING COMPONENTS. THE FULL RANGE OF MODELS WOULD BE:
HEE, HSE, HEF
HXEL, HXEM, HXSL, HXSM, HXFL, HXFM
HER
- THIS APPROVAL IS FOR THE STRUCTURAL CAPACITY OF THE EXTERIOR HOUSING ONLY, IT DOES NOT INCLUDE ANY INTERIOR MECHANISM OR ELECTRICAL PART.
- THIS PRODUCT HAS NOT BEEN TESTED FOR WATER PENETRATION ACCORDING TO FLORIDA BUILDING CODE TAS 100(A) WIND DRIVEN RAIN TEST. IT CANNOT BE INSTALLED WITHIN THE RIDGE AREA FBC 1523.6.5.2.13
- UNIT IS TO INCLUDE A CURB CAP BASE TO FACILITATE MOUNTING OF THE UNIT TO A CURB. THE CURB WILL BE ADEQUATELY ATTACHED TO THE BUILDING STRUCTURE TO SUSTAIN ALL FORCES WHICH MAY BE PRODUCED BY THE PRESCRIBED ENVIRONMENTAL FORCES EXERTED ON THE FAN AND CURB. THE CURB MUST BE ATTACHED TO A STRUCTURAL MEMBER OF THE BUILDING.

CONCRETE DECK: CURB IS TO BE ATTACHED WITH WEDGE TYPE CONCRETE ANCHOR - MINIMUM 3/8" DIAMETER CARBON STEEL - HILTI KWIK BOLT 3 OR EQUAL. MINIMUM 2-1/2" OF ENGAGEMENT IN 2000 PSI MINIMUM CONCRETE. MINIMUM DECK THICKNESS IS 4". SEE TABLE FOR MINIMUM QUANTITY OF ANCHORS REQUIRED PER CURB SIDE.

STEEL ROOF STRUCTURE: CURB IS TO BE ATTACHED WITH SELF-DRILLING STEEL SCREW OF MINIMUM NOMINAL SIZE OF #12. THE SCREW SHALL PASS THROUGH STEEL STRUCTURE AT LEAST 1/2". SEE TABLE FOR MINIMUM QUANTITY OF SCREWS REQUIRED PER CURB SIDE.

WOOD ROOF STRUCTURE: CURB IS TO BE ATTACHED WITH STEEL LAG BOLTS NOMINAL SIZE OF 5/16" DIAMETER OR LARGER. WOOD IS TO BE 4" NOMINAL SIZE OR GREATER. THE BOLT SHALL HAVE A MINIMUM OF 3" OF THREAD ENGAGEMENT AND SHALL BE AT LEAST 1-1/2" FROM MATERIAL EDGE. SEE TABLE FOR MINIMUM QUANTITY OF BOLTS REQUIRED PER CURB SIDE.

- THE CURB SHALL BE CONSTRUCTED OF 5052 ALUMINUM OR G-90 GALVANIZED STEEL OR 300 SERIES STAINLESS STEEL. THE GALVANIZED STEEL CURB MATERIAL THICKNESS SHALL BE 18 GA (0.052") OR GREATER WITH WELDED CORNERS. THE CURB HEIGHT SHALL NOT EXCEED 30".
- THE H-SERIES PROP POWER VENTILATOR SHALL BE ATTACHED TO THE CURB WITH ONE OF THE FOLLOWING METHODS INSTALLED ON ALL FOUR SIDES OF THE CURB CAP. THE FASTENERS SHALL BE 2" FROM EACH CORNER OF THE FAN BASE. THE DISTANCE BETWEEN FASTENERS SHALL BE 5-1/2" OR LESS. THE QUANTITY OF FASTENERS INTO EACH CURB SIDED SHALL EQUAL OR EXCEED THE QUANTITY SHOWN IN THE FASTENER TABLE (AT LEFT).
 - #12 X 2" HEX WASHER HEAD SELF-DRILLING SCREW
 - ALTERNATE FASTENER - .25" HEX HEAD BOLT AND WASHER WITH COMPANION NUT INSTALLED ON THE INTERIOR OF THE CURB.
- ALL FASTENERS ARE TO BE HIGH QUALITY CORROSION RESISTANT STEEL OR STAINLESS STEEL.
- ANY GAP BETWEEN THE CURB AND CURB CAP SHALL BE FILLED BY THE INSTALLING CONTRACTOR WITH A SUITABLE CORROSION RESISTANT MATERIAL THAT ALLOWS THE FASTENERS TO BE INSTALLED WITHOUT CAUSING EXCESSIVE DISTORTION OF THE UNIT FLANGES.
- THE INSTALLER IS RESPONSIBLE FOR CHECKING THAT ALL FASTENERS ARE PROPERLY INSTALLED AND ALL ACCESS PANELS ARE IN PLACE BEFORE PUTTING THE UNIT INTO SERVICE.
- ALL FASTENERS AND ACCESS PANELS MUST BE PROPERLY INSTALLED AFTER MAINTENANCE OPERATIONS FOR UNIT TO MAINTAIN CODE COMPLIANCE.

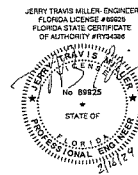

| | | |
|---|--------------------------|--------------|
| MAT'L | - | |
| DRAWN | BFS | 08/15/15 |
| DESIGNER | BFS | SHEET 2 OF 8 |
| DO NOT SCALE DRAWING TOLERANCES UNLESS OTHERWISE NOTED | | |
| DECIMAL | FRACTIONAL | |
| .XX=±.003" | ≤12"=±1/16" | |
| .XXX=±.010" | >12" THRU 96"=±1/8" | |
| .XXXX=±.001" | >96" THRU 144"=±1/4" | |
| ANGULAR | >144"=±3/8" | |
| ±2" | (NC)=NO INSPECTION REQ'D | |
| LOREN COOK CO. MANUFACTURERS OF AIR MOVING EQUIPMENT SPRINGFIELD, MISSOURI | | |
| | | |
| SIZE | DRAWING NO. | REV. |
| B | SD140501-75 | B |

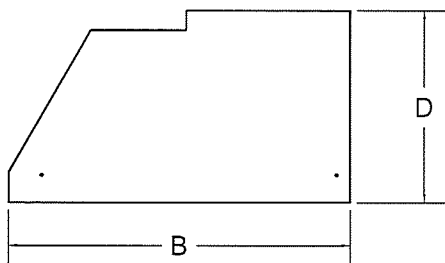
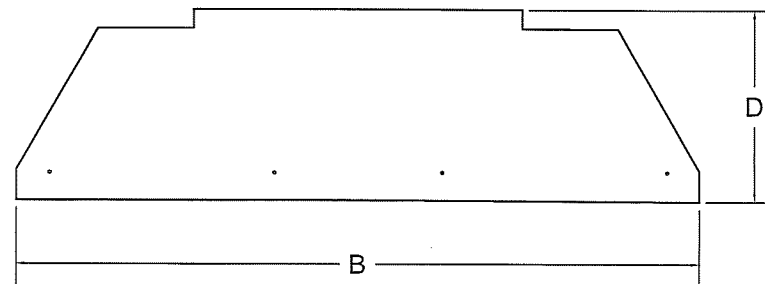
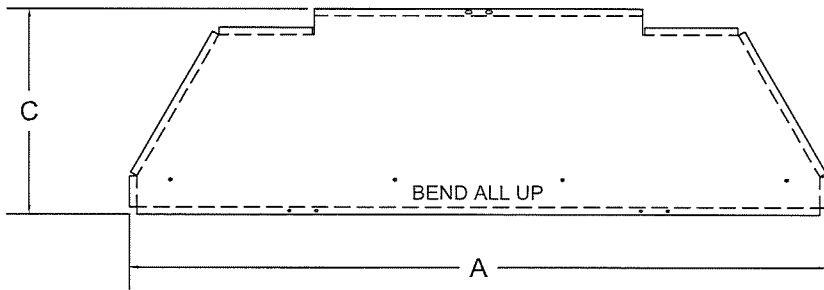

TWO PIECE ON 42NF/36FILTERED AND LARGER

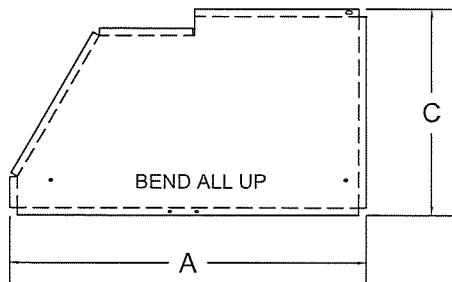

BEND ONE AS SHOWN AND ONE OPPOSITE

HOOD END

| | | | | | | | |
|--------------|----------|-----|-----|-------|-------|-------|-------|
| 48 | 42 | 46 | 44 | 27.00 | 24.81 | 16 | 0.080 |
| 42 | 36 | 46 | 44 | 27.00 | 24.81 | 16 | 0.080 |
| 36 | 30 | 80 | 78 | 22.25 | 20.06 | 16 | 0.080 |
| 30 | 24 | 69 | 67 | 22.25 | 20.06 | 16 | 0.080 |
| 24 | 20 | 59 | 57 | 20.50 | 18.25 | 18 | 0.063 |
| 20 | -- | 53 | 51 | 19.50 | 17.31 | 18 | 0.063 |
| NON FILTERED | FILTERED | A | B | C | D | STEEL | ALUM |
| SIZE | | DIM | DIM | DIM | DIM | GAUGE | THICK |

STEEL: ASTM A653 G90
ALUM: 3003H-14 OR EQUIVALENT

PRODUCT REVISED
as complying with the Florida
Building Code

NOA-No. 24-0311.09

Expiration Date 05/12/2026

By 
Miami-Dade Product Control

JERRY TRAVIS MILLER, ENGINEER
FLORIDA LICENSE #89025
FLORIDA STATE CERTIFICATE
OF AUTHORITY #F04388

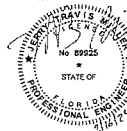

| | | | | | |
|---|----------------------|--------------|---|---------------------------------------|------|
| MAT'L | ASTM 653 G90 | |  | LOREN COOK CO. | |
| DRAWN | BFS | 08/15/15 | | MANUFACTURERS OF AIR MOVING EQUIPMENT | |
| DESIGNER | BFS | SHEET 3 OF 8 | SPRINGFIELD, MISSOURI | | |
| DO NOT SCALE DRAWING TOLERANCES UNLESS OTHERWISE NOTED | | | | | |
| DECIMAL | FRACTIONAL | | H-SERIES PROPELLER FAN | | |
| .XX=±.063" | ≤12"=±1/16" | | ROOF MOUNTED | | |
| .XXX=±.010" | >12" THRU 96"=±1/8" | | HURRICANE RATED | | |
| .XXX=±.001" | >96" THRU 144"=±1/4" | | SIZE | DRAWING NO. | REV. |
| ANGULAR ±2° | >144"=±3/8" | | B | SD140501-75 | B |
| (NC)=NO INSPECTION REQ'D | | | | | |

1-1/2 LONG
 3 PLACE THRU 42
 4 PLACES ON 48

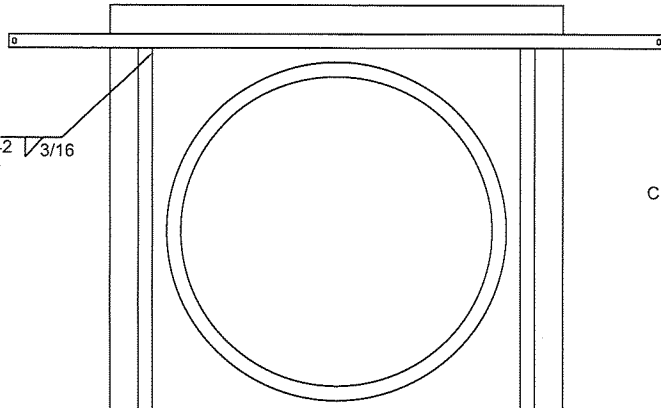

CROSSBRACE PANEL
 "F" GAUGE STEEL

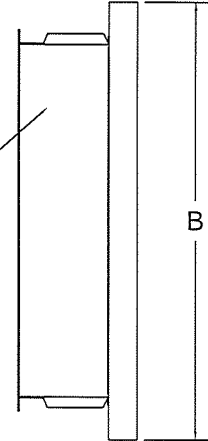

B

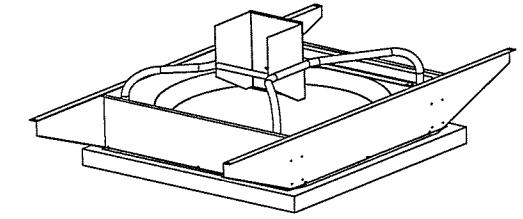

ASSEMBLY SHOWN WITH INTERNAL POWER ASSEMBLY

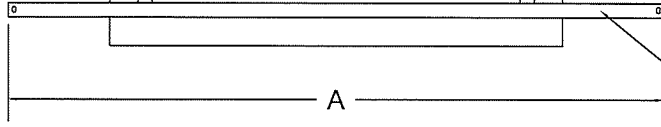

OUTRIGGER PANEL
 "E" GAUGE STEEL

A

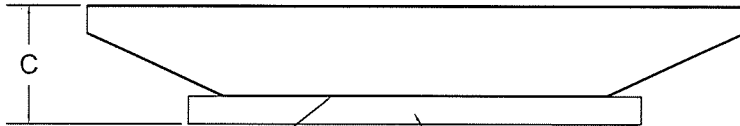

C

2 LONG EACH END
 2-8 ON EDGE

√3/16

BASE "D" GAUGE STEEL

PRODUCT REVISED
 as complying with the Florida
 Building Code
 NOA-No. 24-0311.09
 Expiration Date 05/12/2026
 By *[Signature]*
 Miami-Dade Product Control

| | | | | | | | |
|-------------|----------|-----|-----|-------|-------|-------|-------|
| 48 | 42 | 110 | 60 | 16.31 | 14 | 12 | 16 |
| 42 | 36 | 90 | 54 | 12.81 | 14 | 12 | 16 |
| 36 | 30 | 80 | 48 | 12.81 | 14 | 18 | 18 |
| 30 | 24 | 69 | 42 | 12.81 | 14 | 18 | 18 |
| 24 | 20 | 59 | 36 | 12.81 | 14 | 18 | 18 |
| 20 | -- | 53 | 32 | 12.81 | 14 | 18 | 18 |
| NONFILTERED | FILTERED | A | B | C | D | E | F |
| SIZE | | DIM | DIM | DIM | GAUGE | GAUGE | GAUGE |

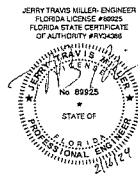

| | | | | | |
|-----------------------------------|------------|--------------------------|---|---------------------------------------|------|
| MAT'L | ASTM A1011 | |  | LOREN COOK CO. | |
| DRAWN | BFS | 08/15/15 | | MANUFACTURERS OF AIR MOVING EQUIPMENT | |
| DESIGNER | BFS | SHEET 4 OF 8 | SPRINGFIELD, MISSOURI | | |
| DO NOT SCALE DRAWING | | | | | |
| TOLERANCES UNLESS OTHERWISE NOTED | | | | | |
| DECIMAL | | FRACTIONAL | | | |
| .XX=±.063" | | ≤12" =±1/16" | | | |
| .XXX=±.010" | | >12" THRU 36" =±1/8" | | | |
| .XXXX=±.001" | | >36" THRU 144" =±1/4" | | | |
| ANGULAR | | >144" =±3/8" | | | |
| ±2' | | (NC)=NO INSPECTION REQ'D | | | |
| | | SIZE | | DRAWING NO. | REV. |
| | | B | | SD140501-75 | B |

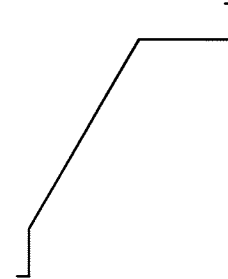
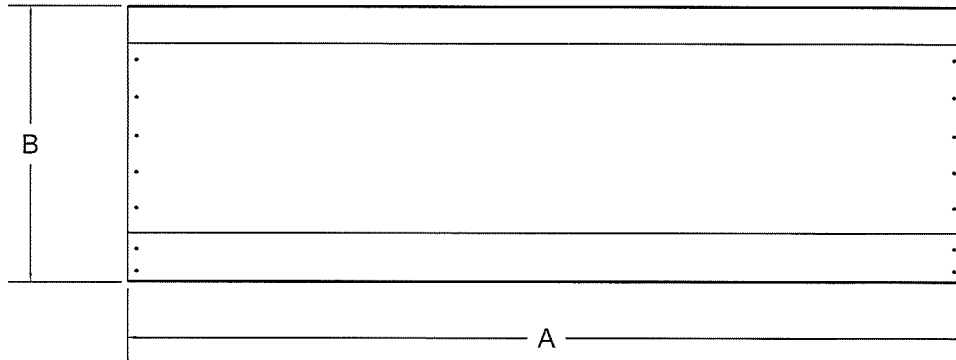

HOOD SIDE

| | | | | | |
|-------------|----------|-----|-------|-------|-------|
| 48 | 42 | 110 | 24.81 | 16 | 0.080 |
| 42 | 36 | 90 | 24.81 | 16 | 0.080 |
| 36 | 30 | 80 | 20.06 | 16 | 0.080 |
| 30 | 24 | 69 | 18.50 | 18 | 0.063 |
| 24 | 20 | 59 | 18.25 | 18 | 0.063 |
| 20 | -- | 53 | 17.31 | 18 | 0.063 |
| NONFILTERED | FILTERED | A | B | STEEL | ALUM |
| SIZE | | DIM | DIM | GAUGE | THICK |

PRODUCT REVISED
 as complying with the Florida
 Building Code
 NOA-No. 24-0311.09
 Expiration Date 05/12/2026
 By 
 Miami-Dade Product Control

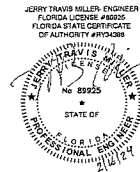

| | | | | | |
|---|--------------------------|--------------|---|--|---|
| MAT'L | ASTM A653 G90 | |  | LOREN COOK CO. | |
| DRAWN | BFS | 08/15/15 | | MANUFACTURERS OF AIR MOVING EQUIPMENT SPRINGFIELD, MISSOURI | |
| DESIGNER | BFS | SHEET 5 OF 8 | | HSERIES PROPELLER FAN ROOF MOUNTED HURRICANE RATED | |
| DO NOT SCALE DRAWING TOLERANCES UNLESS OTHERWISE NOTED | | | | | |
| DECIMAL | FRACTIONAL | | SIZE | | |
| .XX=±.063" | ≤12"=±1/16" | | | | |
| .XXX=±.010" | >12" THRU 96"=±1/8" | | DRAWING NO. | | |
| .XXX=±.001" | >96" THRU 144"=±1/4" | | | | |
| ANGULAR | >144"=±3/8" | | REV. | | |
| ±2" | (NC)=NO INSPECTION REQ'D | | | | |
| B | | | SD140501-75 | | B |

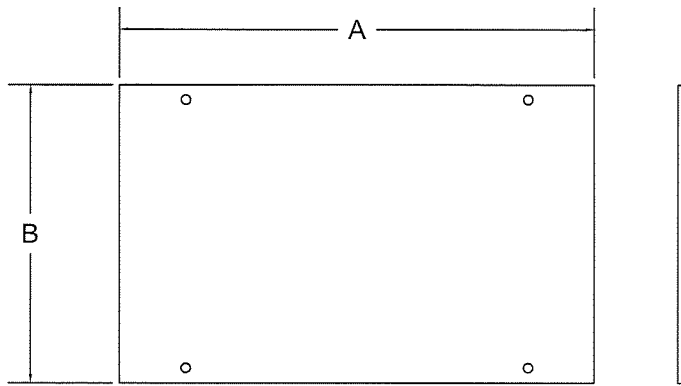

ONE PIECE TOPCAP SIZES 30NF/24F AND SMALLER

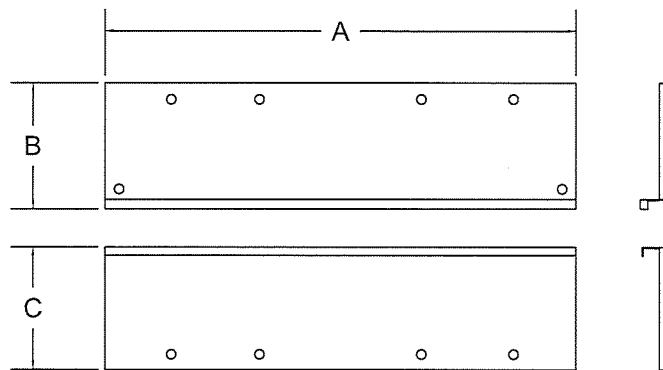



TWO PIECE TOPCAP SIZES 36NF/30F AND LARGER

| | | | | | | |
|-------------|----------|--------|-------|-------|-------|-------|
| 48 | 42 | 110.25 | 22.38 | 22.38 | 16 | 0.080 |
| 42 | 36 | 90.25 | 22.38 | 22.38 | 16 | 0.080 |
| 36 | 30 | 80.25 | 17.38 | 17.38 | 16 | 0.080 |
| 30 | 24 | 69.25 | 32.63 | -- | 18 | 0.063 |
| 24 | 20 | 59.25 | 32.63 | -- | 18 | 0.063 |
| 20 | -- | 53.50 | 30.50 | -- | 18 | 0.063 |
| NONFILTERED | FILTERED | A | B | C | STEEL | ALUM |
| SIZE | | DIM | DIM | DIM | GAUGE | THICK |

TOPCAP

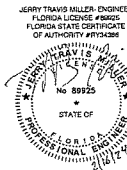
PRODUCT REVISED
 as complying with the Florida
 Building Code
 NOA-No. 24-0311.09
 Expiration Date 05/12/2026
 By *[Signature]*
 Miami-Dade Product Control



| | | | | | |
|-----------------------------------|---------------|--------------------------|---|---------------------------------------|--|
| MAT'L | ASTM A653 G90 | |  | LOREN COOK CO. | |
| DRAWN | BFS | 08/15/15 | | MANUFACTURERS OF AIR MOVING EQUIPMENT | |
| DESIGNER | BFS | SHEET 6 OF 8 | SPRINGFIELD, MISSOURI | | |
| DO NOT SCALE DRAWING | | | | | |
| TOLERANCES UNLESS OTHERWISE NOTED | | | | | |
| DECIMAL | | FRACTIONAL | | | |
| .XX=±.063" | | ≤12"=±1/16" | | | |
| .XXX=±.010" | | >12" THRU 96"=±1/8" | | | |
| .XXX=±.001" | | >96" THRU 144"=±1/4" | | | |
| ANGULAR | | >144"=±3/8" | | | |
| ±2' | | (NC)=NO INSPECTION REQ'D | | | |
| SIZE | DRAWING NO. | | REV. | | |
| B | SD140501-75 | | B | | |

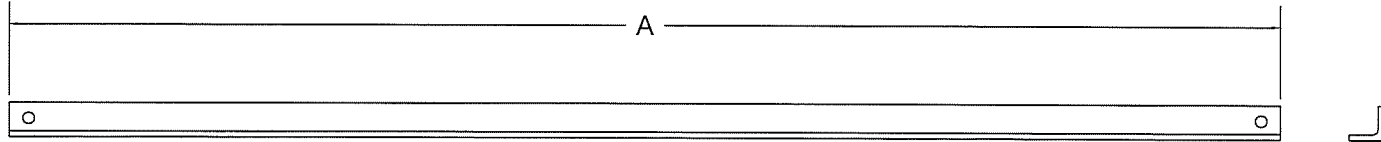

| | | |
|----------------------|-------|----------|
| 42NF, 36F, 48NF, 42F | 29.50 | 4 |
| 30NF, 24F, 36NF, 30F | 41 | 2 |
| UP TO 24/20F | 32 | 2 |
| SIZE | A | QUANTITY |

ALUMINUM HOOD FLANGE REINFORCEMENT
 1.5X1.5X1/4 ALUMINUM ANGLE 6061-T6
 REQUIRED ON OPTIONAL ALUMINUM HOOD ONLY

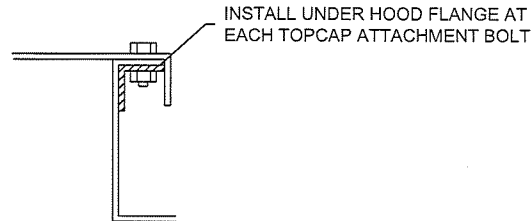
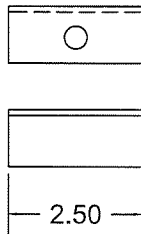



INSTALL UNDER HOOD FLANGE AT
 EACH TOPCAP ATTACHMENT BOLT

| | |
|------------------------|----------|
| SIZE 36/30F AND LARGER | 12 |
| UP TO SIZE 30/24F | 4 |
| SIZE | QUANTITY |

ALUMINUM TOPCAP ATTACHMENT REINFORCEMENT
 1X1X1/8 ALUMINUM ANGLE 6061-T6
 REQUIRED ON OPTIONAL ALUMINUM HOOD ONLY

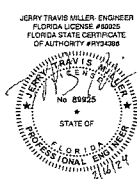
PRODUCT REVISED
 as complying with the Florida
 Building Code
 NOA-No. 24-0311.09
 Expiration Date 05/12/2026
 By *[Signature]*
 Miami-Dade Product Control



| | | |
|---|--------------------------|--------------|
| MAT'L | - | |
| DRAWN | BFS | 08/15/15 |
| DESIGNER | BFS | SHEET 7 OF 8 |
| DO NOT SCALE DRAWING TOLERANCES UNLESS OTHERWISE NOTED | | |
| DECIMAL | FRACTIONAL | |
| .XX=±.063" | ≤12"=±1/16" | |
| .XXX=±.010" | >12" THRU 96"=±1/8" | |
| .XXX=±.001" | >96" THRU 144"=±1/4" | |
| ANGULAR | >144"=±3/8" | |
| ±2' | (NC)=NO INSPECTION REQ'D | |
|  LOREN COOK CO. MANUFACTURERS OF AIR MOVING EQUIPMENT SPRINGFIELD, MISSOURI | | |
| HSERIES PROPELLER FAN ROOF MOUNTED HURRICANE RATED | | |
| SIZE | DRAWING NO. | REV. |
| B | SD140501-75 | B |

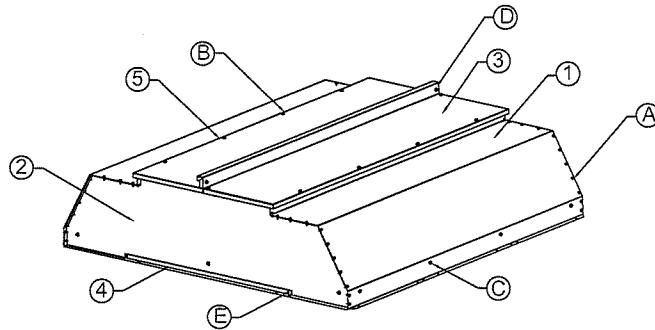

FASTENER TABLE

| ITEM | DESCRIPTION | 20 NONFILTER | 24 NONFILTER 20 FILTER | 30 NONFILTER 24 FILTER | 36 NONFILTER 30 FILTER | 42 NONFILTER 36 FILTER | 48 NONFILTER 42 FILTER |
|------|--|--------------|---------------------------|---------------------------|---------------------------|---------------------------|---------------------------|
| (E) | 5/16 X 1 HEX BOLT / FLANGE NUT / USS WASHER (1"OD) (ALUM ONLY) | 4 | 4 | 4 | 8 | 8 | 8 |
| (D) | 5/16 X 1 HEX BOLT / FLANGE NUT / USS WASHER (1"OD) | -- | -- | -- | 2 | 2 | 2 |
| (C) | 5/16 X 1 HEX BOLT / FLANGE NUT / USS WASHER (1"OD) | 0 | 14 | 14 | 14 | 16 | 20 |
| (B) | 5/16 X 1 HEX BOLT / HEX NUT / USS WASHER (1"OD) | 4 | 4 | 4 | 12 | 12 | 12 |
| (A) | 1/4 X 3/4 LONG SELF-TAPPING SCREWS | 32 | 32 | 40 | 40 | 44 | 44 |
| | | QUANTITIES | | | | | |

| | | |
|------|--------------------------|-------|
| (5) | TOPCAP FLANGE REIN ANGLE | 7 |
| (4) | HOOD FLANGE REIN ANGLE | 7 |
| (3) | TOPCAP | 6 |
| (2) | HOOD END | 3 |
| (1) | HOOD SIDE | 5 |
| ITEM | PART NAME | SHEET |

PRODUCT REVISED
as complying with the Florida
Building Code

NOA-No. 24-0311.09

Expiration Date 05/12/2026

By 
Miami-Dade Product Control



| | | |
|---|--------------------------|--------------|
| MAT'L | - | |
| DRAWN | BFS | 08/15/15 |
| DESIGNER | BFS | SHEET 8 OF 8 |
| DO NOT SCALE DRAWING TOLERANCES UNLESS OTHERWISE NOTED | | |
| DECIMAL | FRACTIONAL | |
| .XX=±.063" | ≤12"=±1/16" | |
| .XXX=±.010" | >12" THRU 96"=±1/8" | |
| .XXXX=±.001" | >96" THRU 144"=±1/4" | |
| ANGULAR | >144"=±3/8" | |
| ±2' | (NC)=NO INSPECTION REQ'D | |
|  LOREN COOK CO. MANUFACTURERS OF AIR MOVING EQUIPMENT SPRINGFIELD, MISSOURI | | |
| H SERIES PROPELLER FAN ROOF MOUNTED HURRICANE RATED | | |
| SIZE | DRAWING NO. | REV. |
| B | SD140501-75 | B |