



**DEPARTMENT OF REGULATORY AND ECONOMIC RESOURCES (RER)  
BOARD AND CODE ADMINISTRATION DIVISION  
NOTICE OF ACCEPTANCE (NOA)**

**MIAMI-DADE COUNTY  
PRODUCT CONTROL SECTION**  
11805 SW 26 Street, Room 208  
Miami, Florida 33175-2474  
T (786) 315-2590 F (786) 315-2599  
[www.miamidade.gov/building](http://www.miamidade.gov/building)

**Amarr Garage Doors dba Entrematic  
165 Carriage Court  
Winston Salem, NC 27105**

**SCOPE:** This NOA is being issued under the applicable rules and regulations governing the use of construction materials. The documentation submitted has been reviewed and accepted by Miami-Dade County RER-Product Control Section to be used in Miami Dade County and other areas where allowed by the Authority Having Jurisdiction (AHJ).

This NOA shall not be valid after the expiration date stated below. The Miami-Dade County Product Control Section (In Miami Dade County) and/or the AHJ (in areas other than Miami Dade County) reserve the right to have this product or material tested for quality assurance purposes. If this product or material fails to perform in the accepted manner, the manufacturer will incur the expense of such testing and the AHJ may immediately revoke, modify, or suspend the use of such product or material within their jurisdiction. RER reserves the right to revoke this acceptance if it is determined by Miami-Dade County Product Control Section that this product or material fails to meet the requirements of the applicable building code.

This product is approved as described herein and has been designed to comply with the Florida Building Code, including the High Velocity Hurricane Zone.

**DESCRIPTION: Model 1200/1225 Heritage/Northwoods 3000 (Dp: +38.7, -48.3 psf) Insulated Steel Sectional Garage Door up to 9'-0" Wide with Optional Impact Resistant Windows**

**APPROVAL DOCUMENT:** Drawing No. **IRC-1209-155-15-I**, titled "Model #1200 Amarr Heritage 3000", sheets 1 through 3 of 3, dated 07/28/2021, prepared by manufacturer, signed and sealed by Thomas L. Shelmerdine, P.E. on 03/02/2026, bearing the Miami-Dade County Product Control revision stamp with the Notice of Acceptance number and expiration date by the Miami-Dade County Product Control Section.

**MISSILE IMPACT RATING: Large and Small Missile Impact Resistant**

**LABELING:** Each unit shall bear a permanent label with the manufacturer's name or logo, manufacturing address, model number, the positive and negative design pressure rating, indicate impact rated if applicable, installation instruction drawing reference number, approval number (NOA), the applicable test standards, and the statement reading 'Miami-Dade County Product Control Approved' is to be located on the door's side track, bottom angle, or inner surface of a panel.

**RENEWAL** of this NOA shall be considered after a renewal application has been filed and there has been no change in the applicable building code negatively affecting the performance of this product.

**TERMINATION** of this NOA will occur after the expiration date or if there has been a revision or change in the materials, use, and/or manufacture of the product or process. Misuse of this NOA as an endorsement of any product, for sales, advertising or any other purposes shall automatically terminate this NOA. Failure to comply with any section of this NOA shall be cause for termination and removal of NOA.

**ADVERTISEMENT:** The NOA number preceded by the words Miami-Dade County, Florida, and followed by the expiration date may be displayed in advertising literature. If any portion of the NOA is displayed, then it shall be done in its entirety.

**INSPECTION:** A copy of this entire NOA shall be provided to the user by the manufacturer or its distributors and shall be available for inspection at the job site at the request of the Building Official.

This NOA **revises NOA # 23-1114.16** and consists of this page 1 and evidence pages E-1 & E-2, as well as approval document mentioned above.

The submitted documentation was reviewed by **Carlos M. Utrera, P.E.**



04/07/26

**NOA No. 25-1218.11**  
**Expiration Date: May 26, 2027**  
**Approval Date: April 16, 2026**  
Page 1

**NOTICE OF ACCEPTANCE: EVIDENCE SUBMITTED**

**1. Evidence submitted under previous NOAs**

**A. DRAWINGS**

1. Drawing No. **IRC-1209-155-15-I**, titled “Model #1200 Amarr Heritage 3000”, sheets 1 through 3 of 3, dated 07/28/2021, prepared by manufacturer, signed and sealed by Thomas L. Shelmerdine, P.E. on 03/30/2022.

**B. TESTS**

1. Test reports on: 1) Uniform Static Air Pressure Test, Loading per FBC TAS 202-94  
2) Large Missile Impact Test per FBC, TAS 201-94  
3) Cyclic Wind Pressure Loading per FBC, TAS 203-94  
4) Forced Entry Test per FBC, TAS 202-94  
5) Tensile Test per ASTM E 8

along with marked-up drawings and installation diagram of a 9’ x 7’ 24 ga. Steel Sectional Garage Door Model # 1200, prepared by American Test Lab, Inc., Report No. **ATLNC-1129.02-21**, dated 02/10/2022, signed and sealed by David W. Johnson, P.E.

2. Test report on Evaluation of Painted or Coated Specimens Subjected to Corrosive Environments per ASTM D1654-08 & ASTM B117-11, prepared by Intertek/Architectural Testing, Inc., Test Report No. **C5463.01-106-18**, dated 04/03/2013, signed and sealed by Joseph A. Reed, P.E.

**C. CALCULATIONS**

1. Anchor calculations prepared by Structural Solutions, P.A., dated 03/30/2022, signed and sealed by Thomas L. Shelmerdine, P.E.

**D. QUALITY ASSURANCE**

1. Miami-Dade Department of Regulatory and Economic Resources (RER).

**E. MATERIAL CERTIFICATIONS**

1. Notice of Acceptance No. **22-0317.02** issued to **Plaskolite, LLC** for their “**TUFFAK Polycarbonate Sheets**”, approved on 04/21/2022 and expiring on 08/27/2027.
2. Test report on Atlas EPS Self-Ignition Temperature per ASTM D1929-16, prepared by Intertek, Test Report No. **102609488MID-002**, dated 06/13/2016, signed and sealed by Frederick D. Curkeet, P.E.
3. UL listing on Atlas EPS Flame Spread and Smoke Developed per UL 723 (ASTM E84), **UL # BRYX.R16529**, dated 02/11/2021.

**F. STATEMENTS**

1. Statement letter of code conformance with **7<sup>th</sup> Edition (2020)** of the **FBC**, and of no financial interest, dated 03/30/2022, issued by Structural Solutions, PA., signed and sealed by Tomas L. Shelmerdine, P.E.



---

**Carlos M. Utrera, P.E.**  
**Product Control Examiner**  
**NOA No. 25-1218.11**  
**Expiration Date: May 26, 2027**  
**Approval Date: April 16, 2026**

**NOTICE OF ACCEPTANCE: EVIDENCE SUBMITTED**

**2. EVIDENCE SUBMITTED UNDER NOA # 23-1114.16 AND NEW**

**A. DRAWINGS**

1. Drawing No. **IRC-1209-155-15-I**, titled “Model #1200 Amarr Heritage 3000”, sheets 1 through 3 of 3, dated 07/28/2021, prepared by manufacturer, signed and sealed by Thomas L. Shelmerdine, P.E. on 03/02/2026.

**B. TESTS**

1. Test reports on:
  - 1) Uniform Static Air Pressure Test, Loading per FBC TAS 202-94
  - 2) Large Missile Impact Test per FBC, TAS 201-94
  - 3) Cyclic Wind Pressure Loading per FBC, TAS 203-94
  - 4) Forced Entry Test per FBC, TAS 202-94
  - 5) Tensile Test per ASTM E 8along with marked-up drawings and installation diagram of a 9’ x 7’ 24 ga. Steel Sectional Garage Door Model 1200 Heritage 3000, prepared by American Test Lab, Inc., Report No. **ATLNC-1013.02-25**, dated 10/15/2025, signed and sealed by David W. Johnson, P.E.

**C. CALCULATIONS**

1. None.

**D. QUALITY ASSURANCE**

1. Miami-Dade Department of Regulatory and Economic Resources (RER).

**E. MATERIAL CERTIFICATIONS**

1. Notice of Acceptance No. **24-0205.09**, issued to **Plaskolite, LLC** for their “**TUFFAK Polycarbonate Sheets**”, approved on 05/09/2024 and expiring on 08/27/2027.

**F. STATEMENTS**

1. Statement letter of code conformance with **8<sup>th</sup> Edition (2023)** of the **FBC**, and of no financial interest, dated 10/27/2023, issued by Structural Solutions, PA., signed and sealed by Tomas L. Shelmerdine, P.E.



---

**Carlos M. Utrera, P.E.**  
**Product Control Examiner**  
**NOA No. 25-1218.11**  
**Expiration Date: May 26, 2027**  
**Approval Date: April 16, 2026**

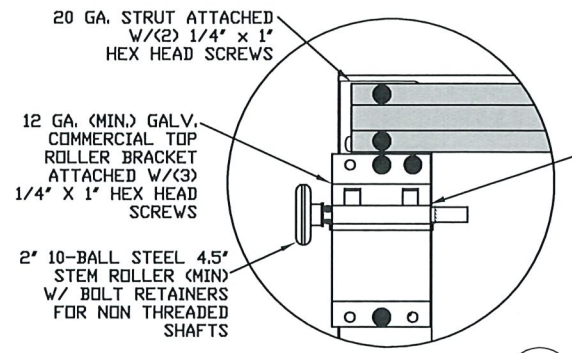

TYPICAL TOP FIXTURES  
N.T.S.

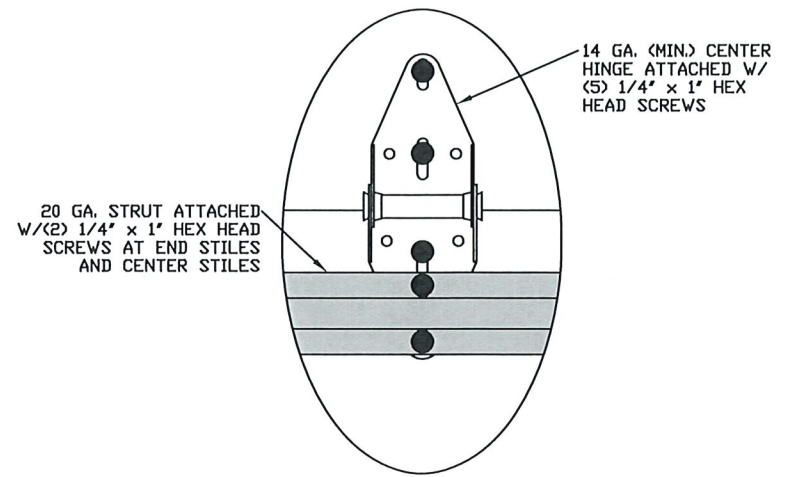

TYPICAL CENTER HINGE  
N.T.S.

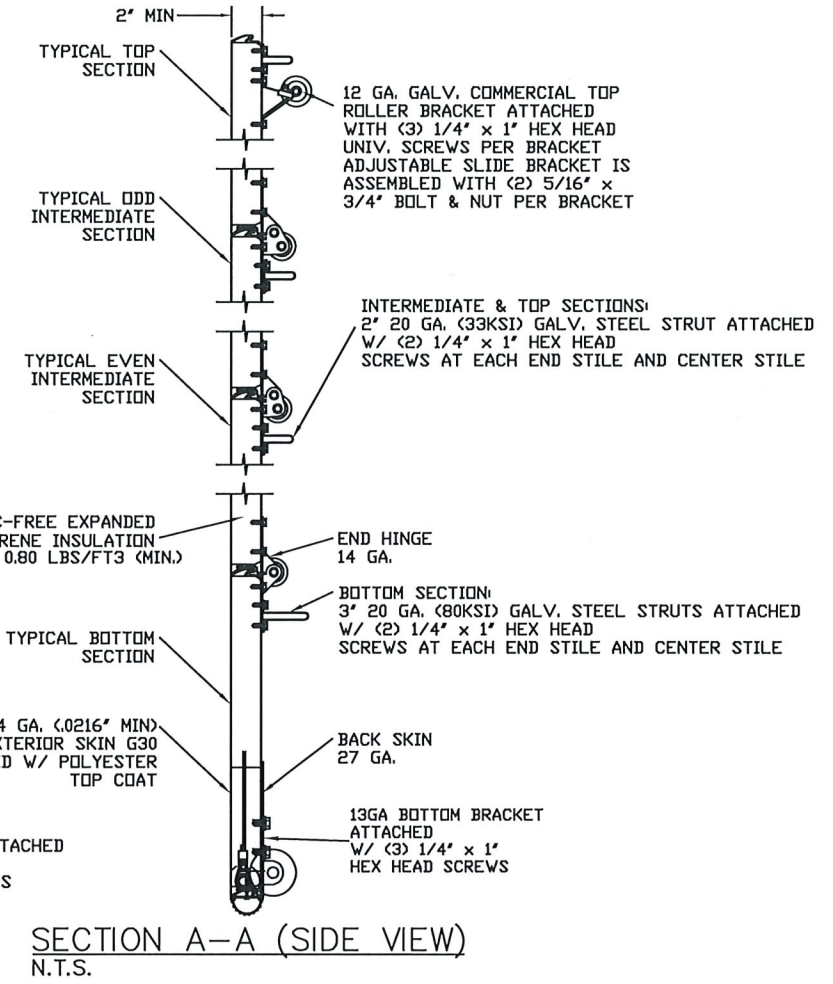

SECTION A-A (SIDE VIEW)  
N.T.S.

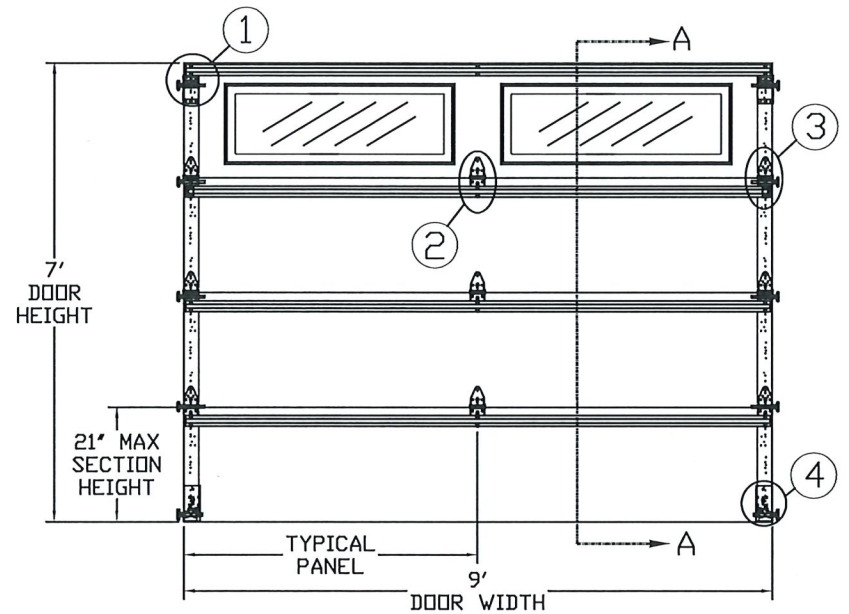

INSIDE ELEVATION  
N.T.S.

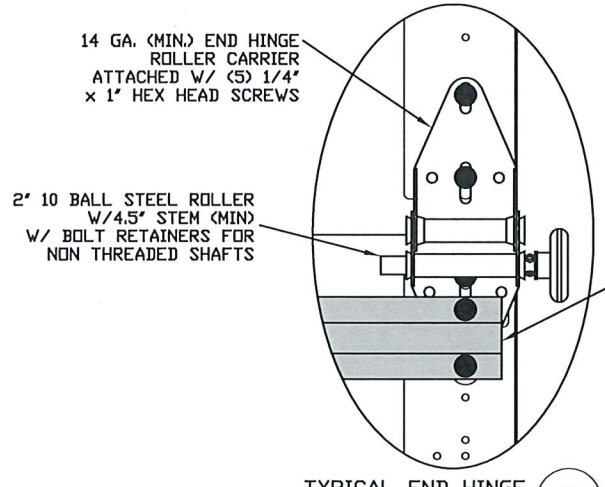

TYPICAL END HINGE  
N.T.S.

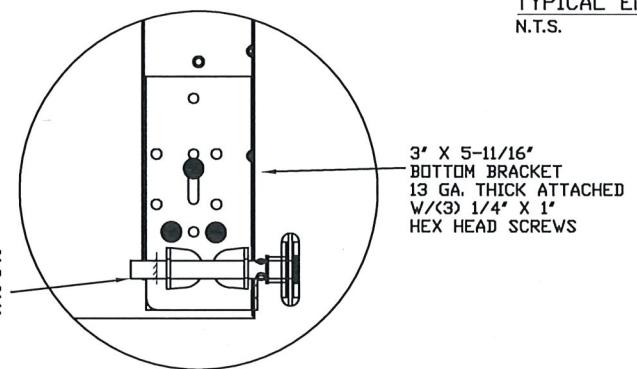

TYPICAL BOTTOM BRACKET  
N.T.S.

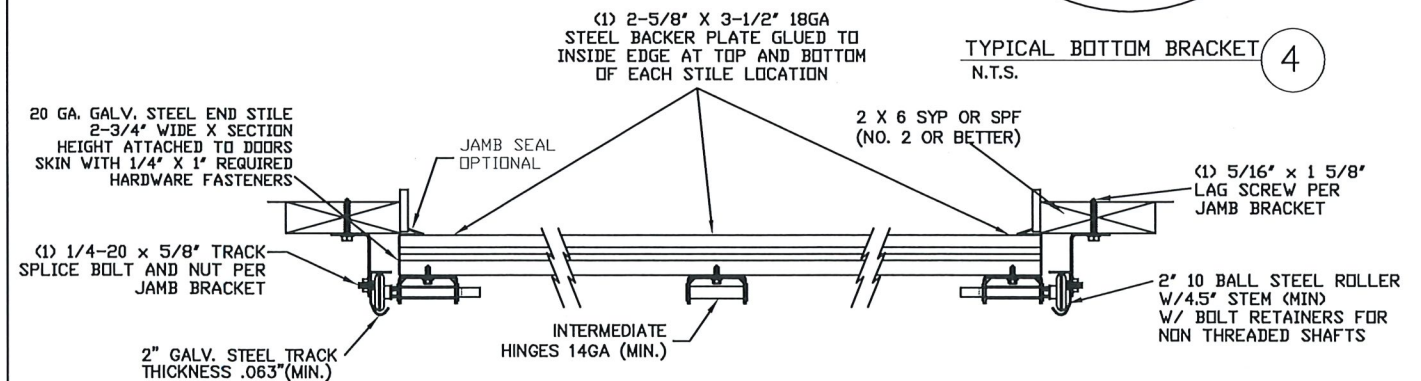

TRACK MOUNTING DETAIL  
N.T.S.

LARGE MISSILE  
IMPACT RESISTANT

**PRODUCT REVISED**  
as complying with the Florida  
Building Code  
NOA-No. 25-1218.11  
Expiration Date 05/26/2027  
By *[Signature]*  
Miami-Dade Product Control

REV	DESCRIPTION OF REVISIONS	DATE	BY

MAX SIZE  
9' x 14'  
DESIGN LOADS  
+38.7 PSF  
-48.3 PSF  
TEST LOADS  
+58.1 PSF  
-72.5 PSF  
LARGE  
MISSILE  
IMPACT  
RESISTANT

Thomas L. Shelmerdine, PE (FL PE #0048579)  
Structural Solutions, PA (FL Firm #29412)

FL

dba Structural Solutions of North Carolina, Inc.  
5921-G W. Friendly Ave., Greensboro, NC 27410

**Amarr**  
ENTRE/MATIC

MODEL #1200 AMARR HERITAGE 3000  
MODEL #1225 AMARR NORTHWOODS 3000

SIZE	DRAWN BY	RLR	DATE	07/28/21	DRAWING NUMBER
B	CHECKED BY	RLR	DATE	07/28/21	IRC-1209-155-15-1

ENTRE/MATIC  
165 CARRIAGE COURT WINSTON-SALEM, N.C. 27105

SHEET 1 OF 3

**OPTIONAL GLAZING LAYOUTS**  
N.T.S.

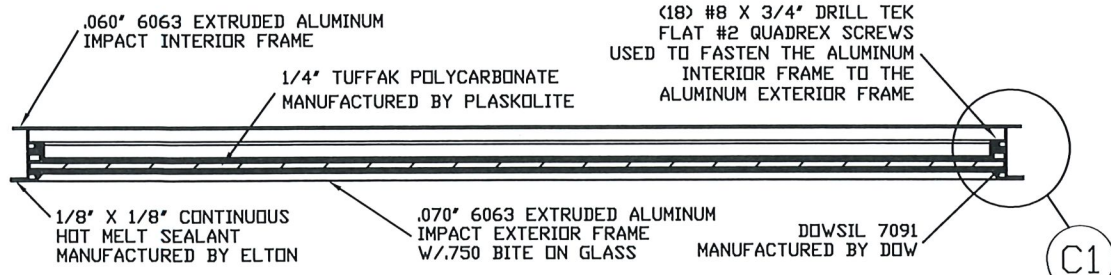
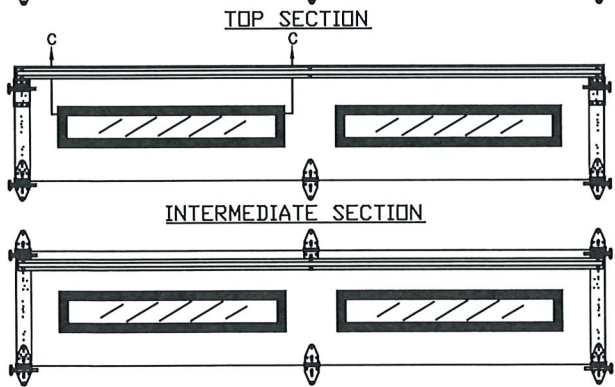
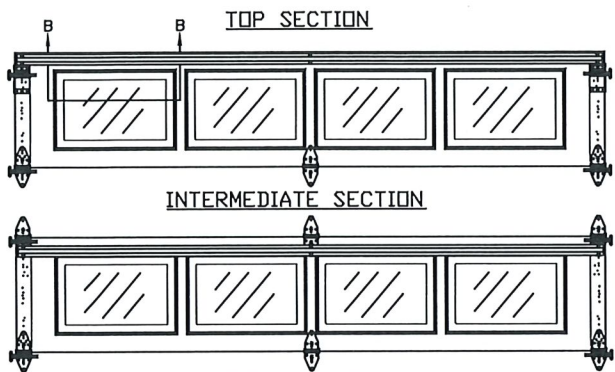
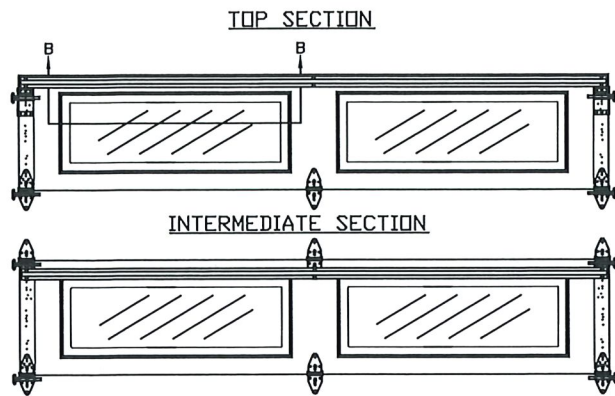

**SECTION C-C IMPACT WINDOW DETAIL**  
N.T.S.

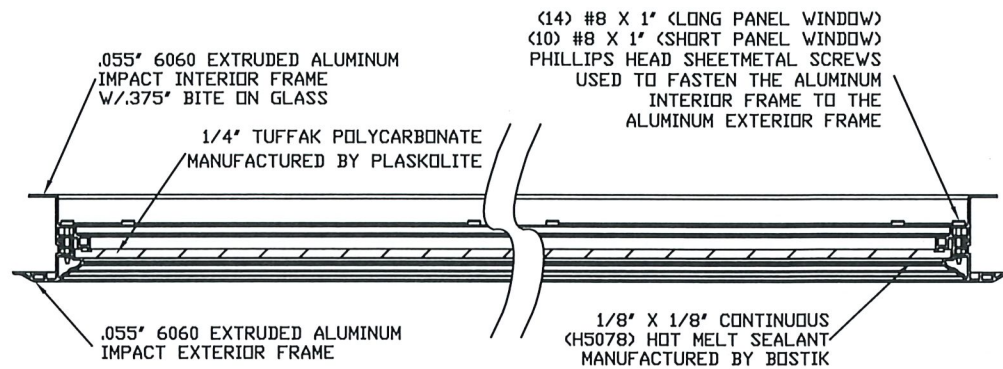

**SECTION B-B IMPACT WINDOW DETAIL**  
N.T.S.

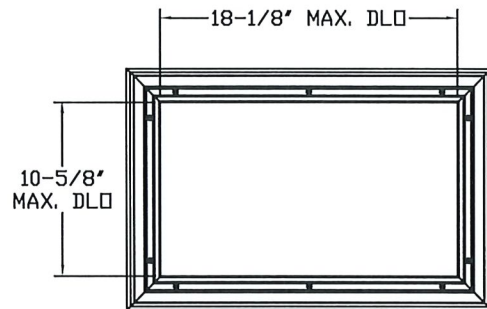

**SHORT PANEL IMPACT GLAZING FASTENER DETAIL**  
N.T.S.

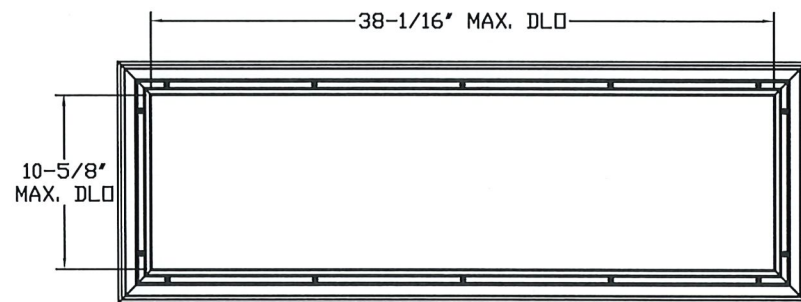

**LONG PANEL IMPACT GLAZING FASTENER DETAIL**  
N.T.S.

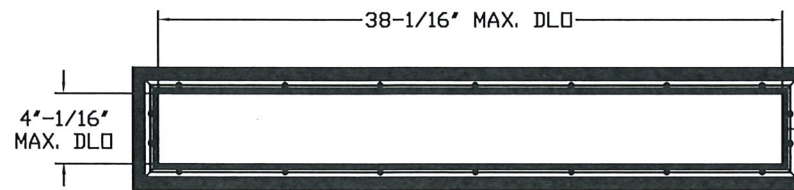

**SLIMLINE IMPACT GLAZING FASTENER DETAIL**  
N.T.S.

**PRODUCT REVISED**  
as complying with the Florida  
Building Code  
NOA-No. 25-1218.11  
Expiration Date 05/26/2027  
By *[Signature]*  
Miami-Dade Product Control

- SPECIFICATIONS AND NOTES**
1. ALL THE LOAD FROM THE DOOR IS TRANSFERRED TO THE VERTICAL TRACK, FROM THE TRACK THE LOAD IS TRANSFERRED TO THE VERTICAL JAMBS. THE HORIZONTAL JAMB OR HEADER RECEIVES NO PORTION OF THE LOAD TRANSFERRED FROM THE DOOR.
  2. EACH VERTICAL JAMBS RECEIVES MAXIMUM DESIGN LOADS OF: +174.2 LBS/FT & -217.4 LBS/FT.
  3. DOOR AND HARDWARE WILL BE DESIGNED, MANUFACTURED AND INSTALLED WITH STANDARDS AS SET FORTH BY DASMA.
  4. DOOR SECTIONS SHALL BE 27GA MIN. INTERIOR AND 24GA MIN. EXTERIOR SKIN ROLLED FORMED, W/ BAKED ON POLYESTER FINISH.
  5. SUPPORTING STRUCTURAL ELEMENTS SHALL BE DESIGNED BY A REGISTERED PROFESSIONAL ENGINEER FOR WIND LOADS INDICATED ON THIS DRAWING IN ADDITION TO OTHER LOADINGS.
  6. PANEL STAMP DOES NOT AFFECT WINDLOAD CAPABILITIES.
  7. THIS APPROVAL REQUIRES THE MANUFACTURER TO DO TESTING OF ALL COILS USED TO FABRICATE DOOR PANELS UNDER THIS NOTICE OF ACCEPTANCE. A MINIMUM OF 2 SPECIMENS SHALL BE CUT FROM EACH COIL AND TENSILE TESTED ACCORDING TO ASTM E-8 BY A DADE COUNTY APPROVED LAB SELECTED AND PAID BY THE MANUFACTURER. EVERY 3 MONTHS, 4 TIMES A YEAR, THE MANUFACTURER SHALL MAIL TO THIS OFFICE: A COPY OF THE TEST REPORTS WITH CONFIRMATION THAT THE SPECIMENS WERE SELECTED FROM COILS AT THE MANUFACTURER PRODUCTION FACILITIES. AND A NOTARIZED STATEMENT FROM THE MANUFACTURER THAT ONLY COILS WITH YIELD STRENGTH OF 47,000 PSI OR MORE SHALL BE USED TO MAKE DOOR PANELS FOR DADE COUNTY UNDER THIS NOTICE OF ACCEPTANCE.

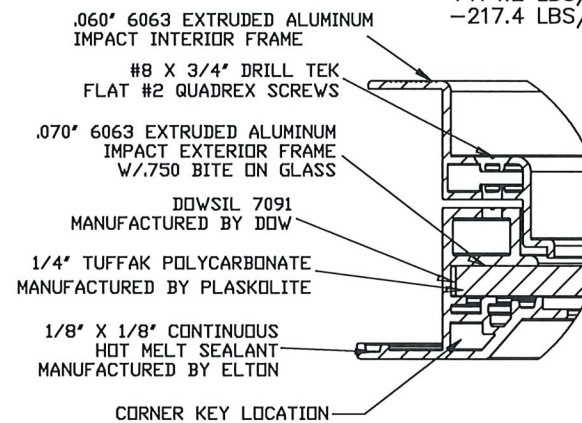
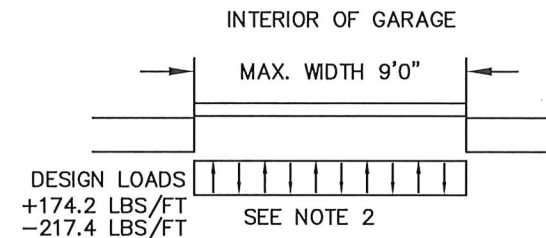

**EXPANDED IMPACT WINDOW DETAIL**  
N.T.S.

REV	DESCRIPTION OF REVISIONS	DATE	BY

MAX SIZE  
9' x 14'  
DESIGN LOADS  
+38.7 PSF  
-48.3 PSF  
TEST LOADS  
+58.1 PSF  
-72.5 PSF

LARGE  
MISSILE  
IMPACT  
RESISTANT

Thomas L. Shelmerdine, PE (FL PE #0048579)  
Structural Solutions, PA (FL Firm #29412)

FL

dba Structural Solutions of North Carolina, Inc.  
5921-G W. Friendly Ave., Greensboro, NC 27410

**Amarr**  
ENTRE/MATIC

**MODEL #1200 AMARR HERITAGE 3000**  
**MODEL #1225 AMARR NORTHWOODS 3000**

SIZE	DRAWN BY	RLR	DATE	07/28/21	DRAWING NUMBER
B	CHECKED BY	RLR	DATE	07/28/21	IRC-1209-155-15-1
ENTRE/MATIC 165 CARRIAGE COURT WINSTON-SALEM, NC. 27105					SHEET 2 OF 3

TABLE 1

DOOR HEIGHT	SECTION HEIGHTS							
	Btm	#2	#3	#4	#5	#6	#7	#8
6' 0"	18"	18"	18"	18"				
6' 6"	21"	18"	18"	21"				
7' 0"	21"	21"	21"	21"				
7' 6"	18"	18"	18"	18"	18"			
8' 0"	21"	18"	18"	18"	21"			
8' 6"	21"	21"	21"	18"	21"			
9' 0"	18"	18"	18"	18"	18"	18"		
9' 6"	21"	18"	18"	18"	18"	21"		
10' 0"	21"	21"	21"	18"	18"	21"		
10' 6"	21"	21"	21"	21"	21"	21"		
11' 0"	21"	18"	18"	18"	18"	18"	21"	
11' 6"	21"	21"	21"	18"	18"	18"	21"	
12' 0"	21"	21"	21"	21"	21"	18"	21"	
12' 6"	21"	18"	18"	18"	18"	18"	18"	21"
13' 0"	21"	21"	21"	18"	18"	18"	18"	21"
13' 6"	21"	21"	21"	21"	21"	18"	18"	21"
14' 0"	21"	21"	21"	21"	21"	21"	21"	21"

TABLE 2

DOOR HEIGHT	TRACK ATTACHMENT								
	A	B	C	D	E	F	G	H	
6' 6"	3.5"	21"	39"	57"					
7'	3.5"	21"	42"	63"					
7' 6"	3.5"	18"	36"	54"	72"				
8'	3.5"	21"	39"	57"	75"				
8' 6"	3.5"	21"	42"	63"	81"				
9'	3.5"	18"	36"	54"	72"	90"			
9' 6"	3.5"	21"	39"	57"	75"	93"			
10'	3.5"	21"	42"	63"	81"	99"			
10' 6"	3.5"	21"	42"	63"	84"	105"			
11'	3.5"	21"	39"	57"	75"	93"	111"		
11' 6"	3.5"	21"	42"	63"	81"	99"	117"		
12'	3.5"	21"	42"	63"	84"	105"	123"		
12' 6"	3.5"	21"	39"	57"	75"	93"	111"	129"	
13'	3.5"	21"	42"	63"	81"	99"	117"	135"	
13' 6"	3.5"	21"	42"	63"	84"	105"	123"	141"	
14'	3.5"	21"	42"	63"	84"	105"	126"	147"	

ALL TRACK ATTACHMENT SPACING +/- 2" ALLOWED WITH SYP OR SPF NO. 2 OR BETTER ONLY

TABLE 3

SECTION	STRUT SIZE
8TH	2"
7TH	2"
6TH	2"
5TH	2"
4TH	2"
3RD	2"
2ND	2"
BOTTOM	3"

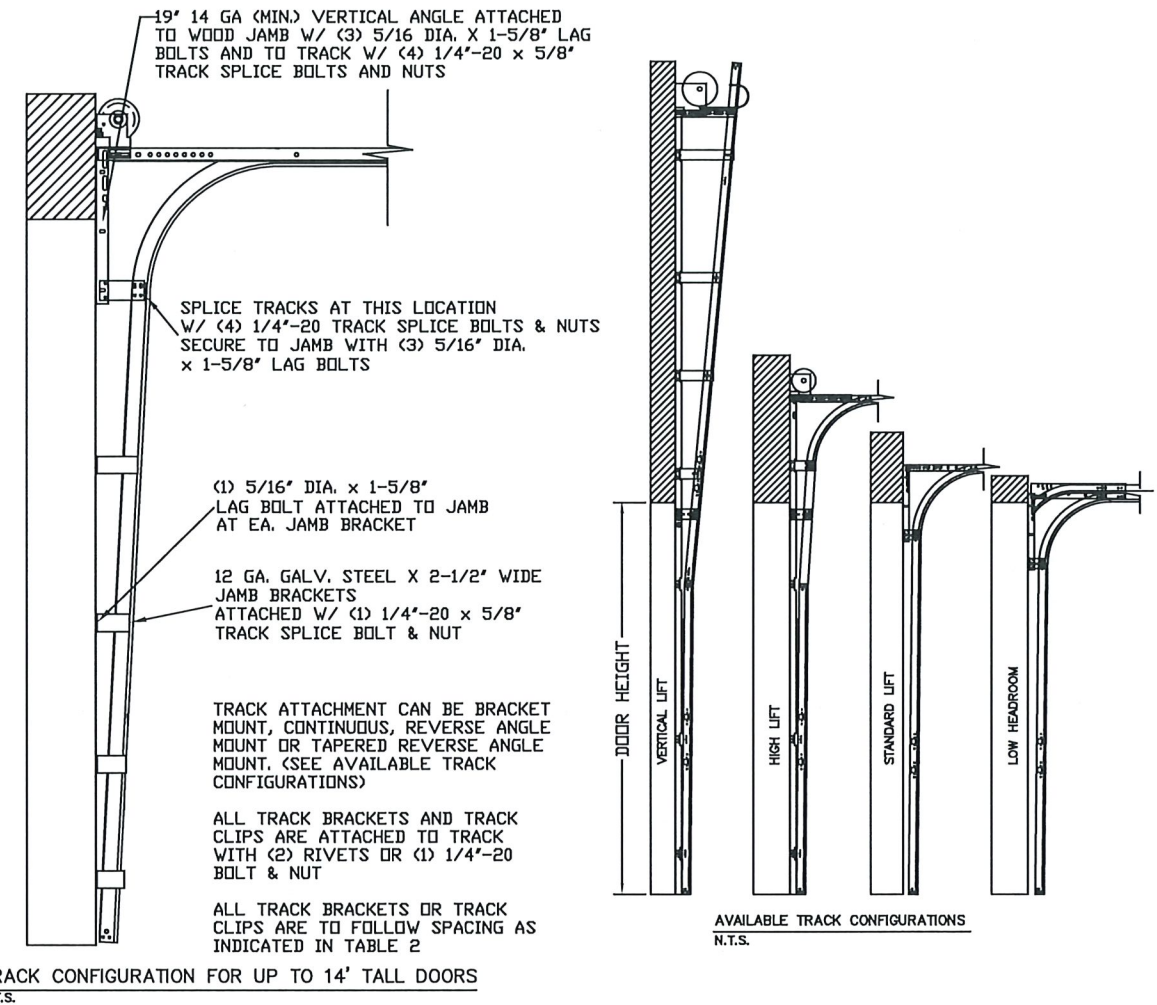

WOOD JAMB ATTACHMENT TO STRUCTURE

**2 X 6 VERTICAL JAMB ATTACHMENT TO WOOD FRAME STRUCTURE**  
 5/16" X 3" LAG SCREWS STARTING 6" FROM ENDS THEN 24" O.C. (1 1/2" EMBEDMENT)

**2 X 6 VERTICAL JAMB ATTACHMENT TO 2,000 PSI CONCRETE**  
 HILTI KWIK BOLT 3/8" X 4" STARTING 6" FROM ENDS THEN 24" O.C. (2 1/2" EMBEDMENT)  
 HILTI SLEEVE ANCHOR 3/8" X 2-3/4" STARTING 6" FROM ENDS THEN 24" O.C. (1 1/4" EMBEDMENT)  
 ITW/RAMSET REDHEAD (TRU-BOLT) 3/8" X 4" STARTING 6" FROM ENDS THEN 24" O.C. (2 1/2" EMBEDMENT)

**2 X 6 VERTICAL JAMB ATTACHMENT TO HOLLOW C-90 BLOCK**  
 SIMPSON 1/4" X 3" TITEN SCREWS STARTING 6" FROM ENDS, USE PAIRS OF FASTENERS (3" APART) AT 16" O.C. (1 1/2" EMBEDMENT)  
 HILTI 1/4" X 2-3/4" KWIK-CON II+ SCREWS STARTING 6" FROM ENDS, USE PAIRS OF FASTENERS (3" APART) AT 16" O.C. (1 1/4" EMBEDMENT)

**2 X 6 VERTICAL JAMB ATTACHMENT TO GROUDED C-90 BLOCK (2000 PSI GROUT)**  
 HILTI SLEEVE ANCHOR 3/8" X 2-3/4" STARTING 6" FROM ENDS THEN 24" O.C. (1 1/4" EMBEDMENT)  
 (OR, USE FASTENERS FOR HOLLOW C-90 BLOCK)

\*LAGS AND BOLTS CAN BE COUNTERSUNK TO PROVIDE A FLUSH MOUNTING SURFACE.  
 \*PREPARATION OF WOOD JAMBS BY OTHERS

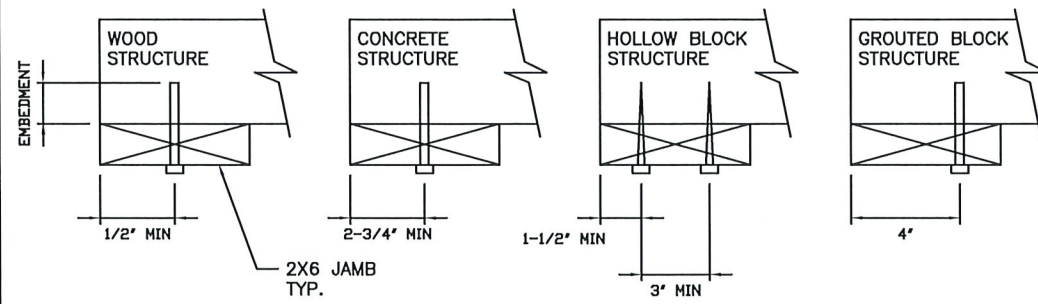

**PRODUCT REVISED**  
 as complying with the Florida Building Code  
 NOA-No. 25-1218.11  
 Expiration Date 05/26/2027  
 By *[Signature]*  
 Miami-Dade Product Control

REV	DESCRIPTION OF REVISIONS	DATE	BY

MAX SIZE 9' x 14'  
 DESIGN LOADS +38.7 PSF -48.3 PSF  
 TEST LOADS +58.1 PSF -72.5 PSF  
 LARGE MISSILE IMPACT RESISTANT

Thomas L. Shelmerdine, PE (FL PE #0048579) Structural Solutions, PA (FL Firm #29412)  
 Thomas L. Shelmerdine, PE (FL PE #0048579) Structural Solutions, PA (FL Firm #29412)  
 dba Structural Solutions of North Carolina, Inc. 5921-G W. Friendly Ave., Greensboro, NC 27410

**THOMAS L. SHELMERDINE**  
 LICENSE No. 48579  
 STATE OF FLORIDA  
 PROFESSIONAL ENGINEER  
 FL

**Amarr**  
 ENTREMATIC

MODEL #1200 AMARR HERITAGE 3000  
 MODEL #1225 AMARR NORTHWOODS 3000

SIZE B	DRAWN BY RLR	DATE 07/28/21	DRAWING NUMBER IRC-1209-155-15-1
	CHECKED BY RLR	DATE 07/28/21	

ENTREMATIC  
 165 CARRIAGE COURT WINSTON-SALEM, N.C. 27105  
 SHEET 3 OF 3