



MIAMI-DADE COUNTY
 PRODUCT CONTROL SECTION
 11805 SW 26 Street, Room 208
 Miami, Florida 33175-2474
 T (786) 315-2590 F (786) 315-2599
www.miamidade.gov/building

DEPARTMENT OF REGULATORY AND ECONOMIC RESOURCES (RER)
 BOARD AND CODE ADMINISTRATION DIVISION
NOTICE OF ACCEPTANCE (NOA)

Amarr Garage Doors dba Entrematic
165 Carriage Court
Winston Salem, NC 27105

SCOPE: This NOA is being issued under the applicable rules and regulations governing the use of construction materials. The documentation submitted has been reviewed and accepted by Miami-Dade County RER-Product Control Section to be used in Miami Dade County and other areas where allowed by the Authority Having Jurisdiction (AHJ).

This NOA shall not be valid after the expiration date stated below. The Miami-Dade County Product Control Section (In Miami Dade County) and/or the AHJ (in areas other than Miami Dade County) reserve the right to have this product or material tested for quality assurance purposes. If this product or material fails to perform in the accepted manner, the manufacturer will incur the expense of such testing and the AHJ may immediately revoke, modify, or suspend the use of such product or material within their jurisdiction. RER reserves the right to revoke this acceptance, if it is determined by Miami-Dade County Product Control Section that this product or material fails to meet the requirements of the applicable building code.

This product is approved as described herein and has been designed to comply with the Florida Building Code, including the High Velocity Hurricane Zone.

DESCRIPTION: Model 1200/1225 Heritage/Northwoods 3000 (Dp: +42.0, -46.0 psf) EPS Insulated Steel Sectional Garage Door up to 18'-0" Wide with Optional Impact Resistant Window

APPROVAL DOCUMENT: Drawing No. **IRC-1218-165-26-F**, titled "Model #1200/1225 Amarr Heritage/Northwoods 3000", sheets 1 through 4 of 4, dated 03/16/2022, prepared by manufacturer, signed and sealed by Thomas L. Shelmerdine, P.E. on 03/02/2026, bearing the Miami-Dade County Product Control Revision stamp with the Notice of Acceptance number and expiration date by the Miami-Dade County Product Control Section.

MISSILE IMPACT RATING: Large and Small Missile Impact Resistant

LABELING: Each unit shall bear a permanent label with the manufacturer's name or logo, manufacturing address, model number, the positive and negative design pressure rating, indicate impact rated if applicable, installation instruction drawing reference number, approval number (NOA), the applicable test standards, and the statement reading 'Miami-Dade County Product Control Approved' is to be located on the door's side track, bottom angle, or inner surface of a panel.

RENEWAL of this NOA shall be considered after a renewal application has been filed and there has been no change in the applicable building code negatively affecting the performance of this product.

TERMINATION of this NOA will occur after the expiration date or if there has been a revision or change in the materials, use, and/or manufacture of the product or process. Misuse of this NOA as an endorsement of any product, for sales, advertising or any other purposes shall automatically terminate this NOA. Failure to comply with any section of this NOA shall be cause for termination and removal of NOA.

ADVERTISEMENT: The NOA number preceded by the words Miami-Dade County, Florida, and followed by the expiration date may be displayed in advertising literature. If any portion of the NOA is displayed, then it shall be done in its entirety.

INSPECTION: A copy of this entire NOA shall be provided to the user by the manufacturer or its distributors and shall be available for inspection at the job site at the request of the Building Official.

This NOA **revises NOA No. 23-1114.13** and consists of this page 1 and evidence page E-1, E-2, E-3 and E-4, as well as approval document mentioned above.

The submitted documentation was reviewed by **Carlos M. Utrera, P.E.**



04/08/26

NOA No. 25-1218.18
Expiration Date: August 22, 2029
Approval Date: April 16, 2026

Amarr Garage Doors dba Entrematic

NOTICE OF ACCEPTANCE: EVIDENCE SUBMITTED

1. EVIDENCE SUBMITTED UNDER PREVIOUS NOA's

A. DRAWINGS

1. Manufacturer's die drawings and sections.
(Submitted under NOA No. 19-0729.02)
2. Drawing No. **IRC-1218-165-26-F**, titled "Model #1200 Heritage & Oak Summit 3000; Short, Long, Flush and Oak Summit Panels", sheets 1 through 3 of 3, dated 05/23/19, prepared by manufacturer, signed and sealed by Thomas L. Shelmerdine, P.E.
(Submitted under NOA No. 19-0729.02)

B. TESTS

1. Test reports on: 1) Uniform Static Air Pressure Test, Loading per FBC TAS 202-94
2) Large Missile Impact Test per FBC, TAS 201-94
3) Cyclic Wind Pressure Loading per FBC, TAS 203-94
4) Tensile Test per ASTM E8
5) Forced Entry Resistance Test per FBC, TAS 202-94
along with marked-up drawings and installation diagram of 18'x 7' 24 ga Model 1200 Steel Garage Doors, prepared by American Test Lab, Inc., Test Report No. **ATLNC 0423.02-19**, dated 06/12/19, signed and sealed by David W. Johnson, P.E.
(Submitted under NOA No. 19-0729.02)
2. Test report on Evaluation of Painted or Coated Specimens (G-30 Galvanized with Polyester Top Coat) Subjected to Corrosive Environments per ASTM D1654-08 and ASTM B117-11, prepared by Intertek/ATI, Test Report No. **C5463.01-106-18**, dated 04/03/13, signed and sealed by Joseph A. Reed, P.E.
(Submitted under NOA No. 19-0729.02)

C. CALCULATIONS

1. Anchor calculations prepared by Structural Solutions, P.A., dated 07/10/19, signed and sealed by Thomas L. Shelmerdine, P.E.
(Submitted under NOA No. 19-0729.02)

D. QUALITY ASSURANCE

1. Miami-Dade Department of Regulatory and Economic Resources (RER)



Carlos M. Utrera, P.E.
Product Control Examiner
NOA No. 25-1218.18
Expiration Date: August 22, 2029
Approval Date: April 16, 2026

Amarr Garage Doors dba Entrematic

NOTICE OF ACCEPTANCE: EVIDENCE SUBMITTED

1. EVIDENCE SUBMITTED UNDER PREVIOUS NOA's (CONTINUED)

E. MATERIAL CERTIFICATIONS

1. UL Evaluation Report on Surface Burning Characteristics per ANSI/UL723, ASTM E84 of Flint Hills Grades 54 and 40 Expandable Polystyrene Resins, **UL ER7503-01**, issued on May 22, 2013.
2. Report on Ignition Temperature of Plastics per ASTM D1929-13 on Flint Hills Resources EPS 6455 and 5454, issued by UL LLC, project 4786090680.1.1, file R7503, dated 12/20/2013, signed by R. K. Laymon.
3. Notice of Acceptance No. **18-0918.06** issued to **Plaskolite, LLC** for its **TUFFAK Polycarbonate Sheets**, approved on 11/15/18 and expiring on 08/27/22.

F. STATEMENTS

1. Statement letter of conformance, complying with **FBC 7th Edition (2020)** and of no financial interest, dated 08/27/20, issued by Structural Solutions, PA., signed and sealed by Thomas L. Shelmerdine, P.E.
(Submitted under NOA No. 20-1015.39)

G. OTHERS

1. Notice of Acceptance No. **19-0729.02**, issued to Amarr Garage Doors dba Entrematic for their Model 1200 Heritage & Oak Summit 3000 EPS Insulated Steel Sectional Garage Door up to 18'-0" Wide and Optional All Impact Resistant Windows (Dp +42.0, -46.0 PSF) approved on 08/22/19 and expiring on 08/22/24.

2. EVIDENCE SUBMITTED UNDER NOA # 22-0414.11

A. DRAWINGS

1. Drawing No. **IRC-1218-165-26-F**, titled "Model #1200 Amarr Heritage 3000", sheets 1 through 4 of 4, dated 03/07/22, prepared by manufacturer, signed and sealed by Thomas L. Shelmerdine, P.E.



Carlos M. Utrera, P.E.
Product Control Examiner
NOA No. 25-1218.18
Expiration Date: August 22, 2029
Approval Date: April 16, 2026

Amarr Garage Doors dba Entrematic

NOTICE OF ACCEPTANCE: EVIDENCE SUBMITTED

2. EVIDENCE SUBMITTED UNDER NOA # 22-0414.11(CONTINUED)

B. TESTS

1. Test reports on: 1) Uniform Static Air Pressure Test, Loading per FBC TAS 202-94,
2) Forced Entry Resistance Test per FBC, TAS 202-94
3) Large Missile Impact Test per FBC, TAS 201-94
4) Cyclic Wind Pressure Loading per FBC, TAS 203-94
5) Tensile Test per ASTM E8

along with marked-up drawings and installation diagram of a Model 1200 Heritage 3000, Amarr 18' x 7', 24 ga. steel Sectional Steel Garage Door, prepared by American Test Lab, Inc., Report No. **ATLNC 0208.01-22**, dated 04/06/22, signed and sealed by David Wesley Johnson, P.E.

C. CALCULATIONS

1. Anchor calculations prepared by Structural Solutions, P.A., dated 04/07/22, signed and sealed by Thomas L. Shelmerdine, P.E.

D. QUALITY ASSURANCE

1. Miami-Dade Department of Regulatory and Economic Resources (RER)

E. MATERIAL CERTIFICATIONS

1. UL Evaluation Report on Surface Burning Characteristics per ANSI/UL723, ASTM E84 of Flint Hills Grades 54 and 40 Expandable Polystyrene Resins, **UL ER7503-01**, issued on May 22, 2013.
2. Report on Ignition Temperature of Plastics per ASTM D1929-13 on Flint Hills Resources EPS 6455 and 5454, issued by UL LLC, project 4786090680.1.1, file R7503, dated 12/20/2013, signed by R. K. Laymon.
3. Notice of Acceptance No. **22-0317.02** issued to **Plaskolite, LLC** for their "**TUFFAK Polycarbonate Sheets**" dated 04/21/22 expiring on 08/27/27.

F. STATEMENTS

1. Statement letter of conformance, complying with **FBC 7th Edition (2020)** and of no financial interest, dated 04/07/22, issued by Structural Solutions, P.A., signed and sealed by Thomas L. Shelmerdine, P.E.



Carlos M. Utrera, P.E.
Product Control Examiner
NOA No. 25-1218.18
Expiration Date: August 22, 2029
Approval Date: April 16, 2026

Amarr Garage Doors dba Entrematic

NOTICE OF ACCEPTANCE: EVIDENCE SUBMITTED

3. EVIDENCE SUBMITTED UNDER NOA # 23-1114.13 AND NEW

A. DRAWINGS

1. Drawing No. **IRC-1218-165-26-F**, titled “Model #1200/1225 Amarr Heritage/Northwoods 3000”, sheets 1 through 4 of 4, dated 03/16/2022, prepared by manufacturer, signed and sealed by Thomas L. Shelmerdine, P.E. on 03/02/2026.

B. TESTS

1. Test reports on: 1) Uniform Static Air Pressure Test, Loading per FBC TAS 202-94
2) Large Missile Impact Test per FBC, TAS 201-94
3) Cyclic Wind Pressure Loading per FBC, TAS 203-94
4) Forced Entry Test per FBC, TAS 202-94
5) Tensile Test per ASTM E 8
along with marked-up drawings and installation diagram of a 9’ x 7’ 24 ga. Steel Sectional Garage Door Model 1200 Heritage 3000, prepared by American Test Lab, Inc., Report No. **ATLNC-1013.02-25**, dated 10/15/2025, signed and sealed by David W. Johnson, P.E.

C. CALCULATIONS

1. None.

D. QUALITY ASSURANCE

1. Miami-Dade Department of Regulatory and Economic Resources (RER)

E. MATERIAL CERTIFICATIONS

1. None.

F. STATEMENTS

1. Statement letter of conformance, complying with **FBC 8th Edition (2023)** and of no financial interest, dated 10/27/2023, issued by Structural Solutions, P.A., signed and sealed by Thomas L. Shelmerdine, P.E.



Carlos M. Utrera, P.E.
Product Control Examiner
NOA No. 25-1218.18
Expiration Date: August 22, 2029
Approval Date: April 16, 2026

WOOD JAMB ATTACHMENT TO STRUCTURE

SPECIFICATIONS AND NOTES

1. ALL THE LOAD FROM THE DOOR IS TRANSFERRED TO THE VERTICAL TRACK, FROM THE TRACK THE LOAD IS TRANSFERRED TO THE VERTICAL JAMBS. THE HORIZONTAL JAMB OR HEADER RECEIVES NO PORTION OF THE LOAD TRANSFERRED FROM THE DOOR.
2. EACH VERTICAL JAMBS RECEIVES MAXIMUM DESIGN LOADS OF: +378.0 LBS/FT & -414.0 LBS/FT
3. DOOR AND HARDWARE WILL BE DESIGNED, MANUFACTURED AND INSTALLED WITH STANDARDS AS SET FORTH BY DASMA.
4. DOOR SECTIONS SHALL BE 24 GA. (.0216) MIN. EXTERIOR SKIN ROLLED FORMED, W/ BAKED ON POLYESTER FINISH
5. DOORS OVER (4) SECTIONS REFER TO TABLES ON PAGE 4
6. SUPPORTING STRUCTURAL ELEMENTS SHALL BE DESIGNED BY A REGISTERED PROFESSIONAL ENGINEER FOR WIND LOADS INDICATED ON THIS DRAWING IN ADDITION TO OTHER LOADINGS.
7. THIS APPROVAL REQUIRES THE MANUFACTURER TO DO TESTING OF ALL COILS USED TO FABRICATE DOOR PANELS UNDER THIS NOTICE OF ACCEPTANCE. A MINIMUM OF 2 SPECIMENS SHALL BE CUT FROM EACH COIL AND TENSILE TESTED ACCORDING TO ASTM E-8 BY A DADE COUNTY APPROVED LAB SELECTED AND PAID BY THE MANUFACTURER. EVERY 3 MONTHS, 4 TIMES A YEAR, THE MANUFACTURER SHALL MAIL TO THIS OFFICE: A COPY OF THE TEST REPORTS WITH CONFIRMATION THAT THE SPECIMENS WERE SELECTED FROM COILS AT THE MANUFACTURER PRODUCTION FACILITIES. AND A NOTARIZED STATEMENT FROM THE MANUFACTURER THAT ONLY COILS WITH YIELD STRENGTH OF 40,000 PSI OR MORE SHALL BE USED TO MAKE DOOR PANELS FOR DADE COUNTY UNDER THIS NOTICE OF ACCEPTANCE.

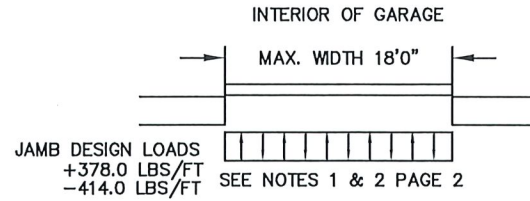

- 2 X 6 VERTICAL JAMB ATTACHMENT TO WOOD FRAME STRUCTURE**
 5/16" X 3" LAG SCREWS STARTING 6" FROM ENDS THEN 12" O.C. (1 1/2" EMBEDMENT)
2 X 6 VERTICAL JAMB ATTACHMENT TO 2,000 PSI CONCRETE
 HILTI KWIK BOLT 3/8" X 4" STARTING 6" FROM ENDS THEN 24" O.C. (2 1/2" EMBEDMENT)
 HILTI SLEEVE ANCHOR 3/8" X 2-3/4" STARTING 6" FROM ENDS THEN 10" O.C. (1 1/4" EMBEDMENT)
 ITW/RAMSET REDHEAD (TRU-BOLT) 3/8" X 4" STARTING 6" FROM ENDS THEN 22" O.C. (2 1/2" EMBEDMENT)
2 X 6 VERTICAL JAMB ATTACHMENT TO HOLLOW C-90 BLOCK
 SIMPSON 1/4" X 3" TITEN SCREWS STARTING 6" FROM ENDS, USE PAIRS OF FASTENERS (3" APART) AT 8" O.C. (1 1/2" EMBEDMENT)
 HILTI 1/4" X 2-3/4" KWIK-CON II+ SCREWS STARTING 6" FROM ENDS, USE PAIRS OF FASTENERS (3" APART) AT 8" O.C. (1 1/4" EMBEDMENT)
2 X 6 VERTICAL JAMB ATTACHMENT TO GROUTED C-90 BLOCK (2000 PSI GROUT)
 HILTI SLEEVE ANCHOR 3/8" X 2-3/4" STARTING 6" FROM ENDS THEN 12" O.C. (1 1/4" EMBEDMENT) (OR, USE FASTENERS FOR HOLLOW C-90 BLOCK)

*LAGS AND BOLTS CAN BE COUNTERSUNK TO PROVIDE A FLUSH MOUNTING SURFACE.
 *PREPARATION OF WOOD JAMBS BY OTHERS

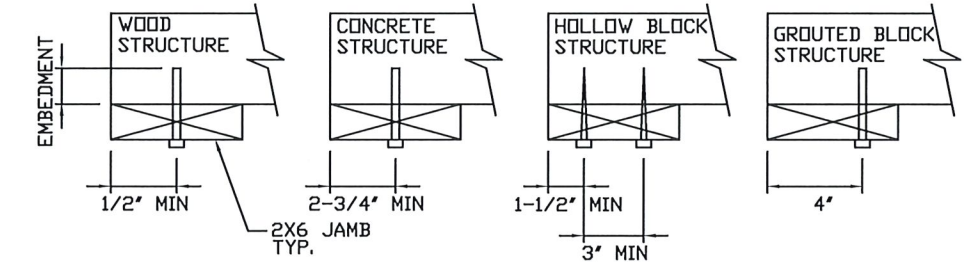

PRODUCT REVISED
 as complying with the Florida Building Code
 NOA-No. 25-1218.18
 Expiration Date 08/22/2029
 By *[Signature]*
 Miami-Dade Product Control

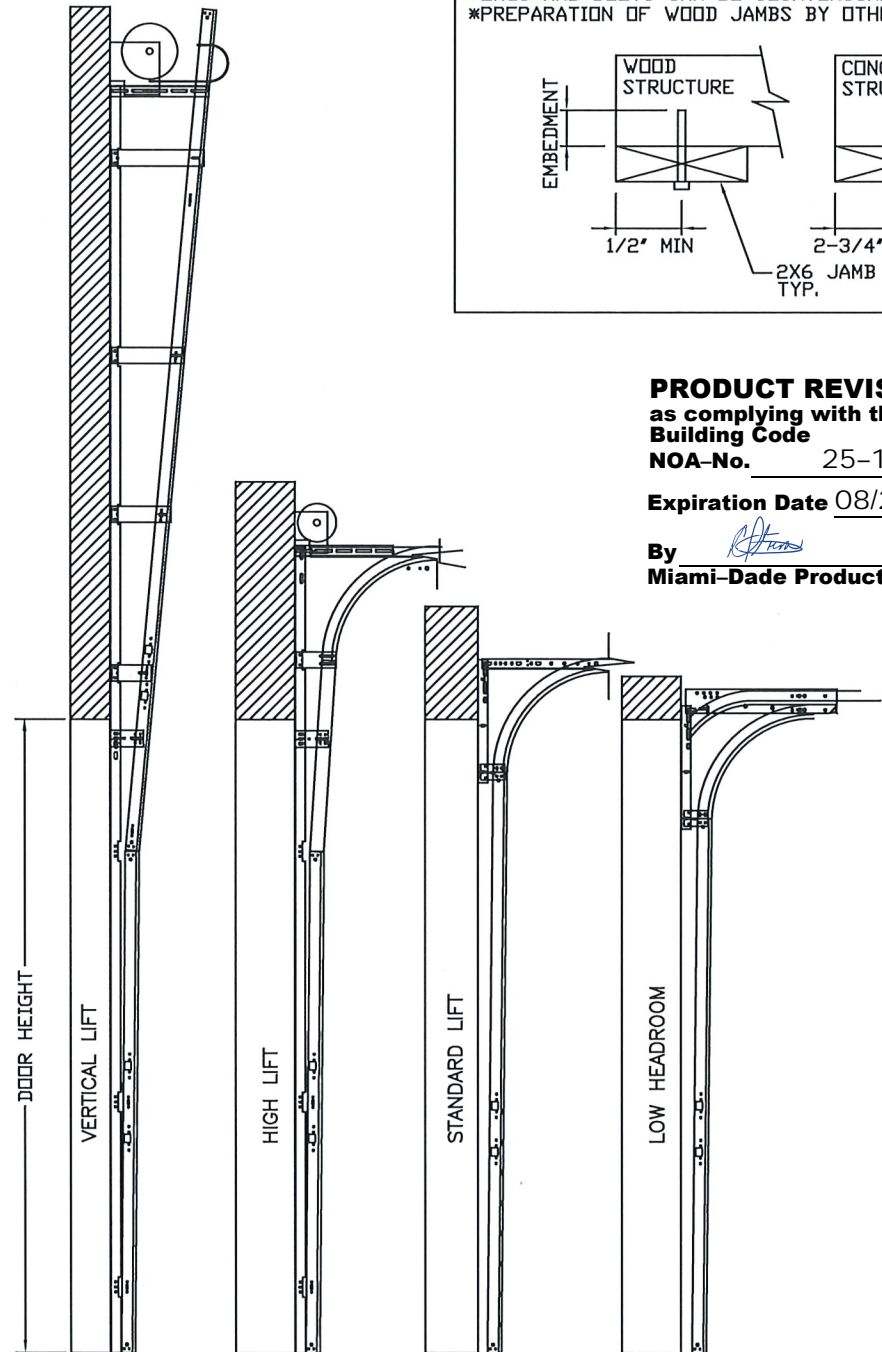
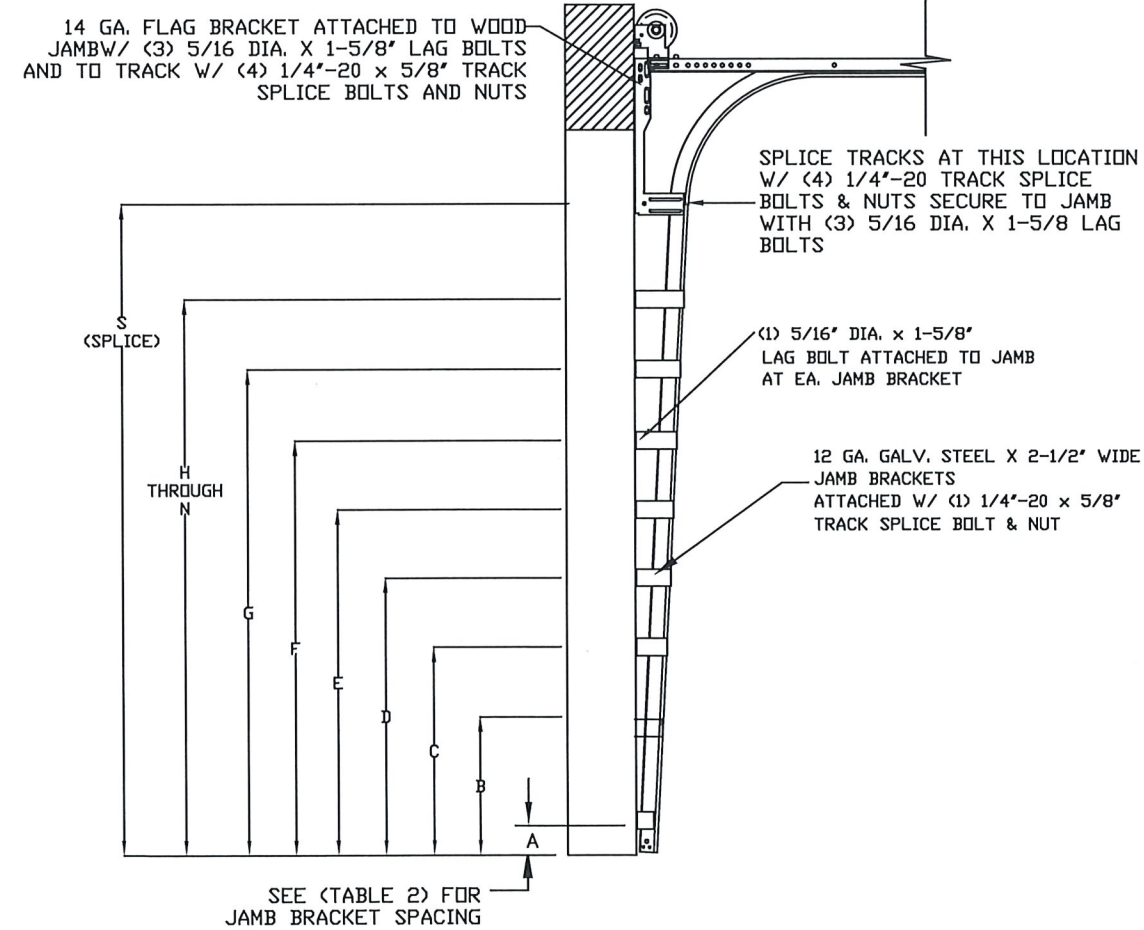

SEE (TABLE 2) FOR JAMB BRACKET SPACING
 STANDARD TRACK CONFIGURATION FOR 6'6" UP TO 14' TALL DOORS
 N.T.S.

AVAILABLE TRACK CONFIGURATIONS
 N.T.S.

REV	DESCRIPTION OF REVISIONS	DATE	BY

MAX SIZE 18' x 14'

DESIGN LOADS +42.0 PSF -46.0 PSF

LARGE MISSILE IMPACT RESISTANCE

Thomas L. Shelmerdine, PE (FL PE #0048579)
 Structural Solutions, PA (FL Firm #29412)

FL

Thomas L. Shelmerdine, Inc.
 dba Structural Solutions of North Carolina, Inc.
 5921-G W. Friendly Ave., Greensboro, NC 27410

MODEL #1200 AMARR HERITAGE 3000
 MODEL #1225 AMARR NORTHWOODS 3000

SIZE B	DRAWN BY DRC	DATE 03/07/22	DRAWING NUMBER IRC-1218-165-26-F
	CHECKED BY RLR	DATE 03/16/22	
ENTREMATIC 165 CARRIAGE COURT WINSTON-SALEM, NC. 27105			SHEET 2 OF 4

EXAMPLES OF OPTIONAL SHORT, LONG,
AND SLIMLINE PANEL GLAZING LAYOUTS
GLAZING AVAILABLE IN ANY COMBINATION

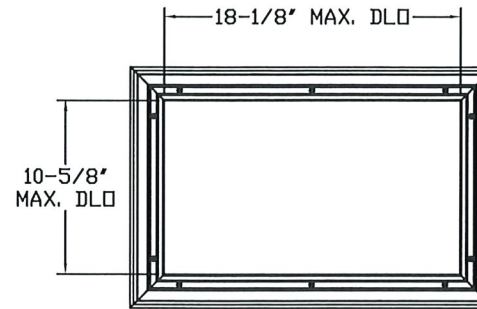
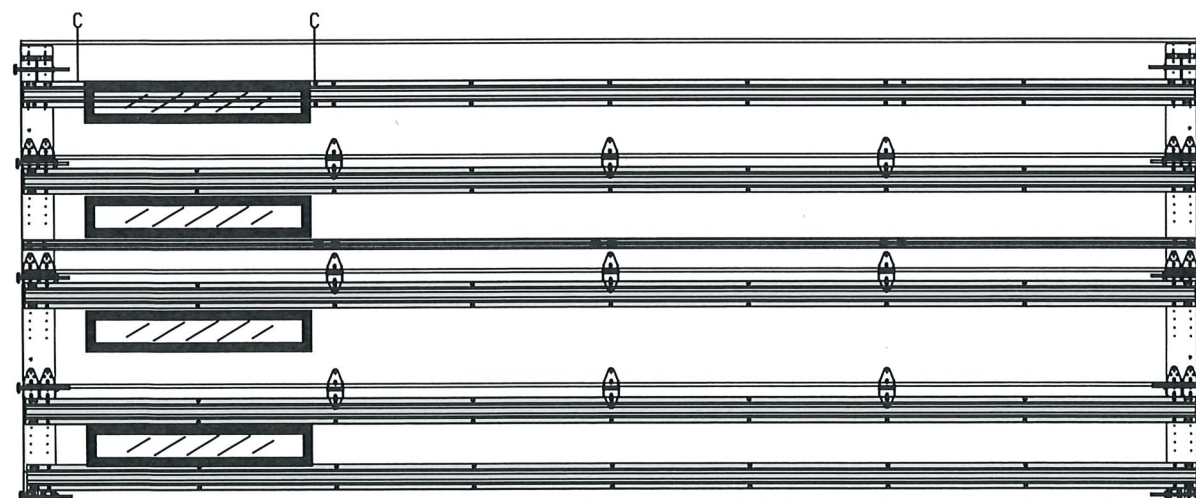
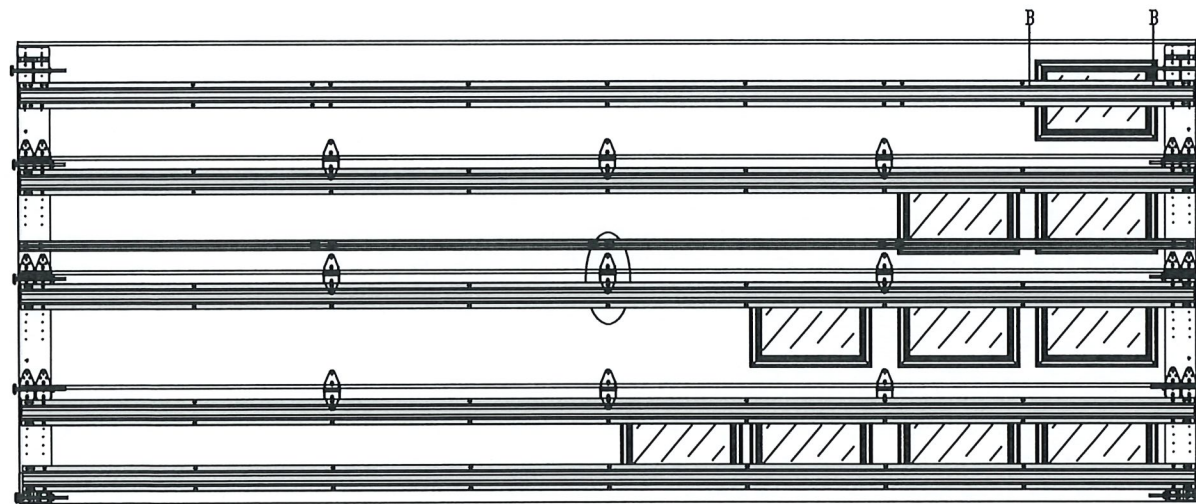
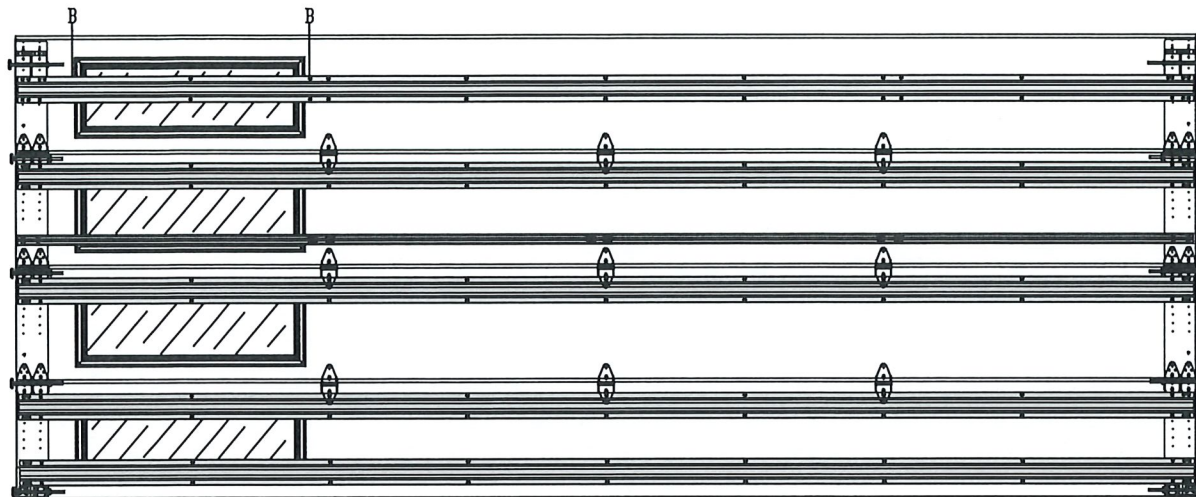

SHORT PANEL IMPACT GLAZING FASTENER DETAIL
N.T.S.

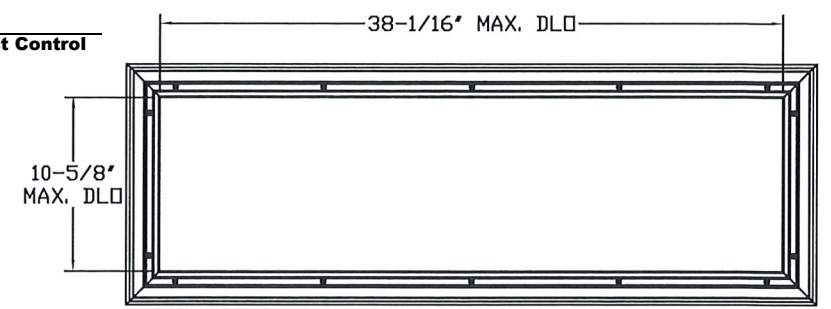

LONG PANEL IMPACT GLAZING FASTENER DETAIL
N.T.S.

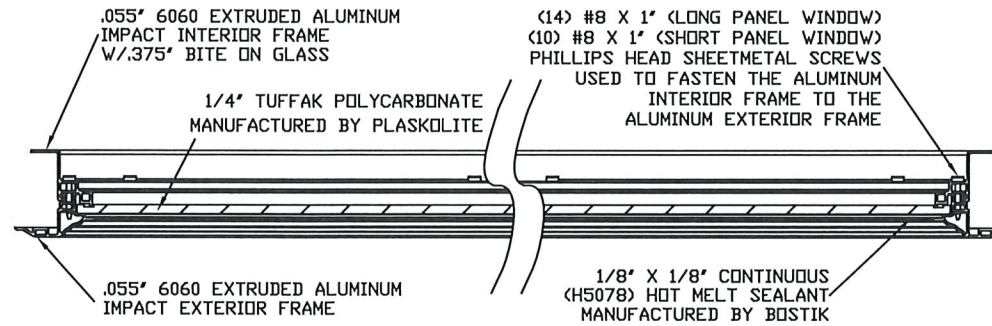

SECTION B-B IMPACT WINDOW DETAIL
N.T.S.

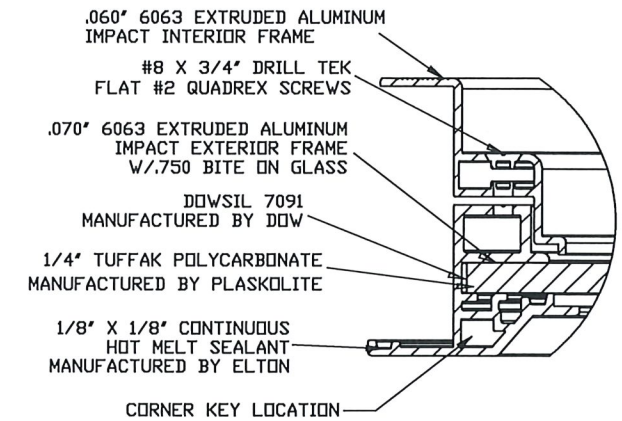

EXPANDED IMPACT WINDOW DETAIL (C1)
N.T.S.

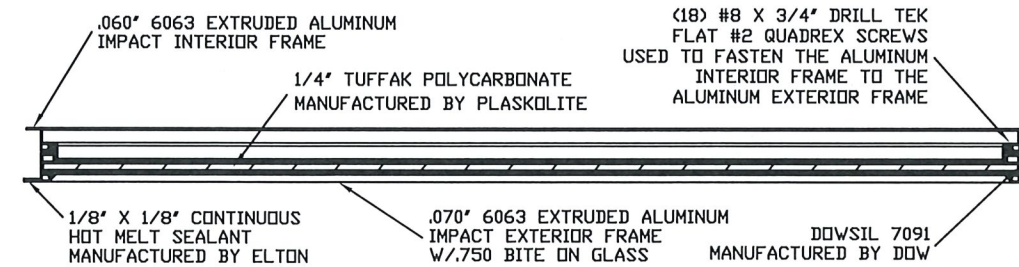

SECTION C-C IMPACT WINDOW DETAIL
N.T.S.

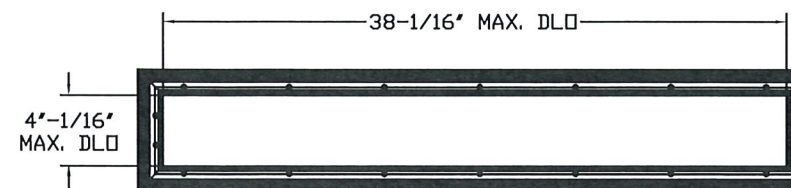

SLIMLINE IMPACT GLAZING FASTENER DETAIL
N.T.S.

PRODUCT REVISED
as complying with the Florida
Building Code
NOA-No. 25-1218.18
Expiration Date 08/22/2029
By *[Signature]*
Miami-Dade Product Control

REV	DESCRIPTION OF REVISIONS	DATE	BY

MAX SIZE 18' x 14'		Thomas L. Shelmerdine, PE (FL PE #0048579) Structural Solutions, PA (FL Firm #29412) dba Structural Solutions of North Carolina, Inc. 5921-G W. Friendly Ave., Greensboro, NC 27410	
DESIGN LOADS +42.0 PSF -46.0 PSF			
LARGE MISSILE IMPACT RESISTANCE			
MODEL #1200 AMARR HERITAGE 3000 MODEL #1225 AMARR NORTHWOODS 3000			
SIZE B	DRAWN BY ORC	DATE 03/07/22	DRAWING NUMBER IRC-1218-165-26-F
	CHECKED BY RLR	DATE 03/16/22	
ENTREMATIC 165 CARRIAGE COURT WINSTON-SALEM, N.C. 27105			SHEET 3 OF 4

TABLE 1

DOOR HEIGHT	SECTION HEIGHTS							
	Btm	#2	#3	#4	#5	#6	#7	#8
14' 0"	21"	21"	21"	21"	21"	21"	21"	21"
13' 6"	21"	21"	21"	21"	21"	18"	18"	21"
13' 0"	21"	21"	21"	18"	18"	18"	18"	21"
12' 6"	21"	18"	18"	18"	18"	18"	18"	21"
12' 0"	21"	21"	21"	21"	21"	18"	21"	
11' 6"	21"	21"	21"	18"	18"	18"	21"	
11' 0"	21"	18"	18"	18"	18"	18"	21"	
10' 6"	21"	21"	21"	21"	21"	21"		
10' 0"	21"	21"	21"	18"	18"	21"		
9' 6"	21"	18"	18"	18"	18"	21"		
9' 0"	18"	18"	18"	18"	18"	18"		
8' 6"	21"	21"	21"	18"	21"			
8' 0"	21"	18"	18"	18"	21"			
7' 6"	18"	18"	18"	18"	18"			
7' 0"	21"	21"	21"	21"				
6' 6"	21"	18"	18"	21"				

TABLE 2

DOOR HEIGHT	TRACK ATTACHMENT															SPLICE
	A	B	C	D	E	F	G	H	I	J	K	L	M	N	S	
6' 6"	3"	14"	27"	38"	46"	56"	64"									70"
7'	3"	14"	27"	38"	46"	56"	68"									76"
7' 6"	3"	14"	27"	38"	46"	56"	68"	78"								82"
8'	3"	14"	27"	38"	46"	56"	68"	78"								88"
8' 6"	3"	14"	27"	38"	46"	56"	68"	78"	88"							94"
9'	3"	14"	27"	38"	46"	56"	68"	78"	88"							100"
9' 6"	3"	14"	27"	38"	46"	56"	68"	78"	88"	98"						106"
10'	3"	14"	27"	38"	46"	56"	68"	78"	88"	100"						112"
10' 6"	3"	14"	27"	38"	46"	56"	68"	78"	88"	100"	110"					118"
11'	3"	14"	27"	38"	46"	56"	68"	78"	88"	100"	110"					124"
11' 6"	3"	14"	27"	38"	46"	56"	68"	78"	88"	100"	110"	120"				130"
12'	3"	14"	27"	38"	46"	56"	68"	78"	88"	100"	110"	122"				136"
12' 6"	3"	14"	27"	38"	46"	56"	68"	78"	88"	100"	109"	122"	132"			142"
13'	3"	14"	27"	38"	46"	56"	68"	78"	88"	100"	114"	122"	134"			148"
13' 6"	3"	14"	27"	38"	46"	56"	68"	78"	88"	100"	109"	122"	134"	144"		154"
14'	3"	14"	27"	38"	46"	56"	68"	78"	88"	100"	114"	122"	134"	146"		160"

ALL TRACK ATTACHMENT SPACING +/-2" ALLOWED WITH SYP NO. 2 OR BETTER ONLY

TABLE 3

SECTION	STRUT SIZE
TOP	5.5"
	3"
7TH	5.5"
	3"
6TH	5.5"
	3"
5TH	5.5"
	3"
4TH	5.5"
	3"
3RD	5.5"
	3"
2ND	5.5"
	3"
BOTTOM	5.5"
	4.5"

REV	DESCRIPTION OF REVISIONS	DATE	BY

MAX SIZE 18' x 14'

DESIGN LOADS +42.0 PSF -46.0 PSF

LARGE MISSILE IMPACT RESISTANCE

Thomas L. Shelmerdine, PE (FL PE #0048579) Structural Solutions, PA (FL Firm #29412)

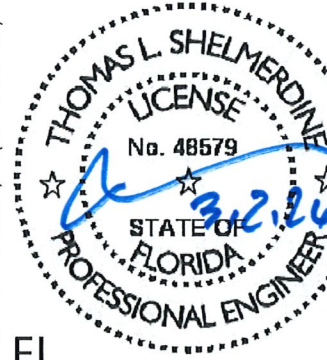

FL

Amarr
ENTREMATIC

MODEL #1200 AMARR HERITAGE 3000
MODEL #1225 AMARR NORTHWOODS 3000

SIZE	DRAWN BY	ORC	DATE	03/07/22	DRAWING NUMBER IRC-1218-165-26-F
B	CHECKED BY	RLR	DATE	03/16/22	

ENTREMATIC
165 CARRIAGE COURT WINSTON-SALEM, N.C. 27105

SHEET 4 OF 4

PRODUCT REVISED
as complying with the Florida Building Code
NOA-No. 25-1218.18
Expiration Date 08/22/2029
By *[Signature]*
Miami-Dade Product Control